

Rimoldi®

Made in Italy

Rimoldi

Rimoldi

Rimoldi

Rimoldi

SIRIO II

- 6.200 RPM

- 1 or multineedle chain stitch flat bed machine

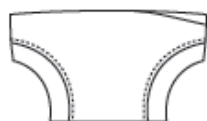
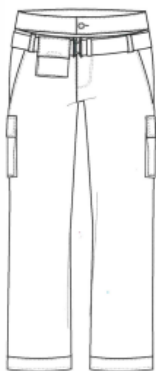

Rimoldi

Rimoldi

Rimoldi

Rimoldi

DIVERSIFIED: a wide range of machines for different requirements

- 61F: flatbed machine for interlock stitch without top covering thread: 2 needles (406) and 3 needles (407)
- 63F: flatbed machine for interlock stitch with top covering thread: 2 needles (602), 3 needles (605) and 4 needles (607)
- 64F: double chain stitch flatbed machine (401)
- 68F: 2 and 3 needle flatbed machine for interlock stitch with bottom covering thread (double chain-stitch 401)
- needle distance 3,5 mm; 4,5 mm; 5 mm or 6 mm

PERFORMING: the best of its range

- Sirio II offers the best performances, productivity, seam quality and machine life
- Speed (up to 7.000 stitches/minute)
- New feeding system
- Oil pump lubrication
- Designed to accept many electronic and pneumatic devices

OPERATING: benefits

- External stitch-length adjustment lever
- External differential-feed adjustment lever
- External oil level
- Looper thread take up cam positioning in front for easy excesses
- Easy threading

FLEXIBLE

- Sirio II can easily meet all requirement
- New feed dog clamp
- New looper mechanism
- Wide differential feed range
- Adjustable needle bar stroke
- Needle-guard with independent movement
- Easily removable needle clamp
- Independent needle-threads control

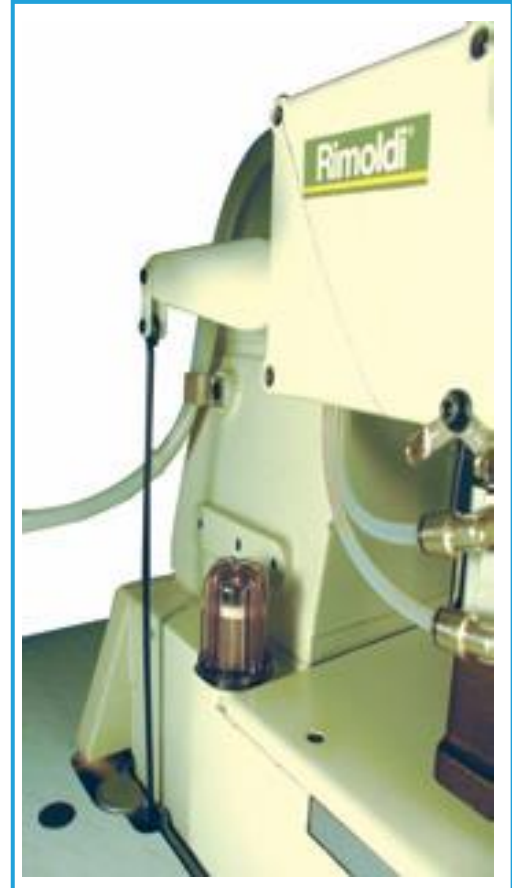

Flexsystem and flexibility of Sirio II

Sirio II is the first modular flat bed machine proposing a new idea in sewing. The Sirio II can perform many types of sewing operations; do to the availability of interchangeable kits. The kits allow the machine to be changed to accommodate the never-ending changes in production. This makes for a good investment in equipment



1. Rear puller kit

Creates the most efficient feeding system

2. Top cover thread kit

To get an interlock stitch with top covering thread with 2-3- 4 needles (602- 605-607)

3. Fixed desengageable fabric knife kit to trim the fabric edge prior to sewing

4. Mechanical metering roller kits

To feed and control tension on elastic coming from above or be low

5. Under bed thread trimmer kit

For looper and needle threads cutting

6. Upper thread trimmer kit

For cutting the top cover thread

7. Mechanical or electronic top metering roller kit

To feed and control tension on elastic coming from above

8. Kit tape cutter

For fast cut- ting of col- larettes and elastic tapes

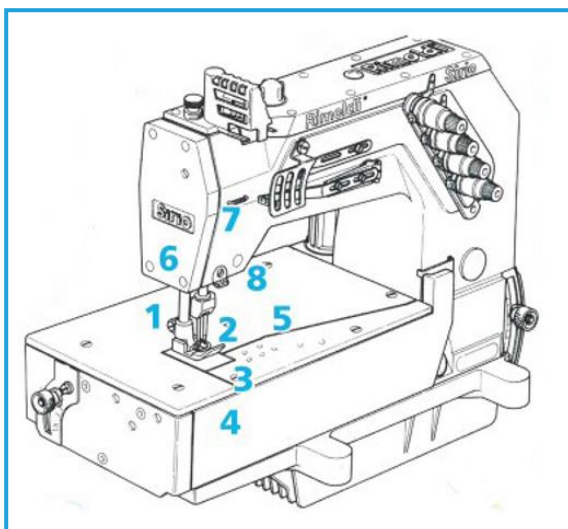
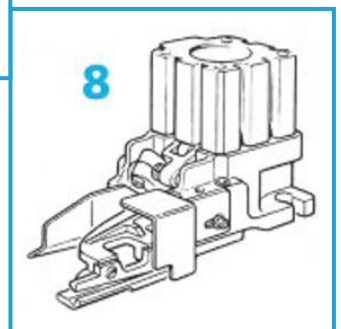
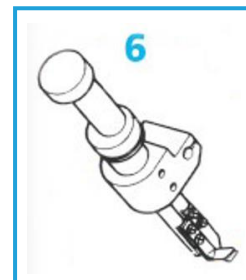
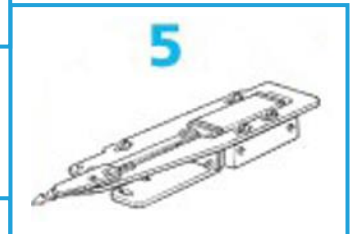
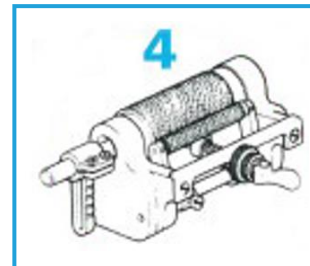
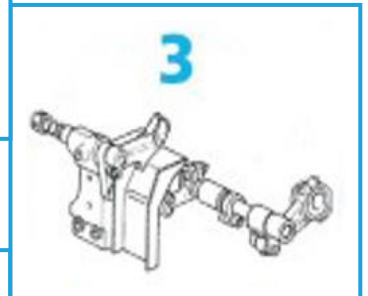
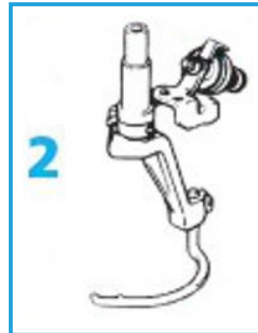

Rimoldi®

Made in Italy

Dal 1881 cuciamo relazioni uniche

Rimoldi

Rimoldi

Rimoldi

Rimoldi

La nuova gamma di
macchine RIMOLDI:
un supporto all'industria
dell'abbigliamento
per una scelta garantita
e di qualità

The new range of
RIMOLDI machines:
an important support
for the garments industry
for a guaranteed and quality choice

