

Rimoldi®

Made in Italy

Rimoldi

Rimoldi

Rimoldi

Rimoldi

FENIX

- 6.200 RPM
- Cylinder bed sewing machine for tubular seams

- Knitwear
- Swimwear
- Corsetry
- Underwear

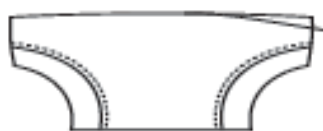
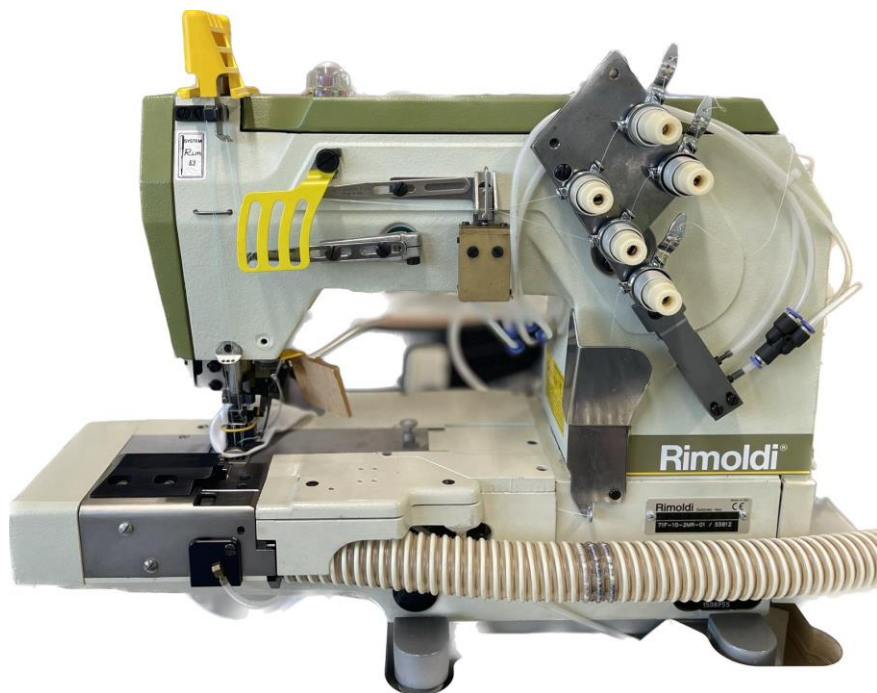

Rimoldi

Rimoldi

Rimoldi

Rimoldi

Fenix

DIVERSIFIED: a wide range for any requirements

- F71: 2 or 3 needle cylinder bed head to get: 2 needle (406) interlock stitch without cover; 3 needle (407) interlock stitch without cover. Needle distances 3,5 mm; 4,5 mm; 5 mm or 6 mm
- F73: 2, 3 or 4 needle cylinder bed machine to get: 2 needle (602) interlock stitch without cover; 3 needle (605) interlock stitch with cover; 4 needle (407) interlock stitch with cover
- F74: 1 needle cylinder bed machine to get: 1 needle (401) double chainstitch

PERFORMING: the best of the range

- Speed (up to 6.200 RPM)
- High efficiency of feeding system
- Wide range of special sophisticated electropneumatic devices
- Forced lubrication pump

SEL-SUFFICIENT: maintenance reduced of 70%

- New system for no-oil leakage on needle bar and presser foot bar
- New external oil filter
- Maximum reliability even on extreme use conditions
- Easy presser foot replacement

OPERATING: from words to deeds

- Fast precise push-button stitch length adjustment
- Adjustable differential feed
- High quality seam with any kind of threads
- Direct reading oil level
- Simple threading

ERGONOMIC AND SAFE

- Antireflection colours
- Low noise level (under C€ standards)
- C€ labour protections
- Easy and comfortable handling of the garments

FLEXIBLE

- Wide range of kits for different kinds of sewing operation
- Adjustable needle bar stroke
- Front and rear movable and independent needle guards
- Quick and easy conversion
- Easy to change needle holding clamp

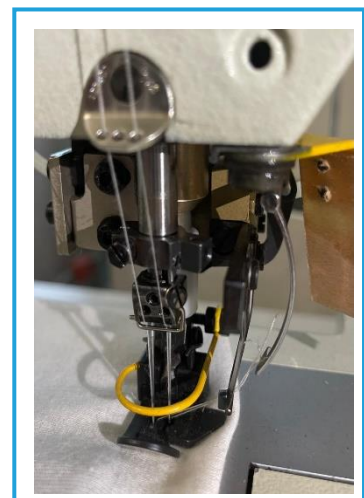
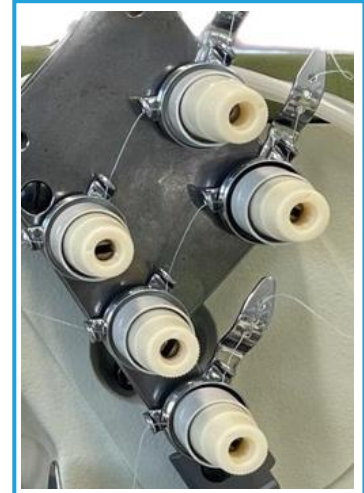

Flexsystem and flexibility of Fenix

The Garments Market is continuously evolving and for this reason Rimoldi decided to support and to promote FLEXSYSTEM. Thanks to interchangeable kits the machine has an excellent flexibility to meet with the always different market requirements



1. Rear puller kit

In order to adapt the machine to the different requirements of fabric

2. Cover kit

In order to obtain 2,3 and 4 needle interlock stitch with upper cover

3. Disengageable/ fixed trimming knife kit

In order to trim the edge of the material when attaching elastic

4. Mechanical upper metering roller kit

In order to feed elastic from above in a regular and continuous way

5. Lower thread cutting device kit

In order to cut the needle and looper threads

6. Upper thread cutting device kit

In order to cut the cover thread

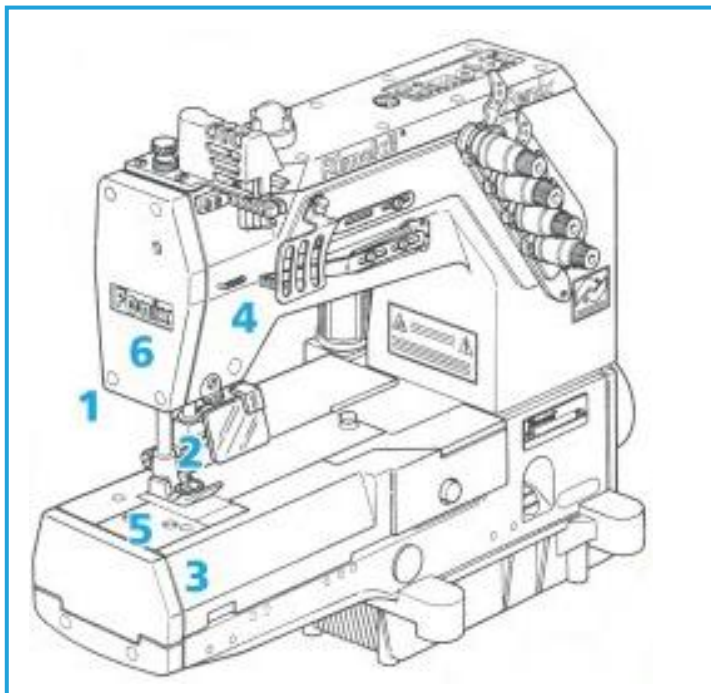
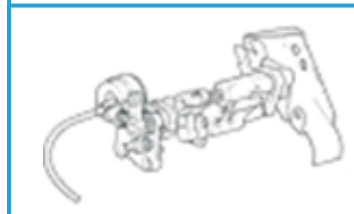
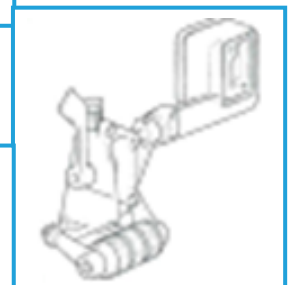
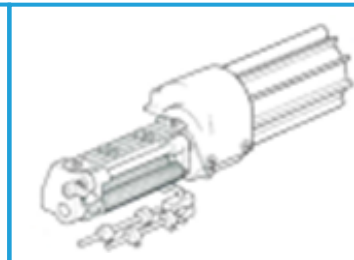
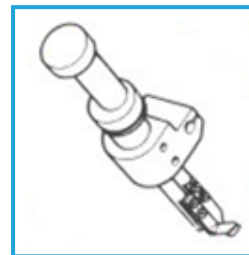

Rimoldi®

Made in Italy

Dal 1881 cuciamo relazioni uniche

Rimoldi

Rimoldi

Rimoldi

Rimoldi

La nuova gamma di
macchine RIMOLDI:
un supporto all'industria
dell'abbigliamento
per una scelta garantita
e di qualità

The new range of
RIMOLDI machines:
an important support
for the garments industry
for a guaranteed and quality choice

