

# **FLEXSYSTEM<sup>®</sup>**

## **Vega**

**F27-34-1TD-02**

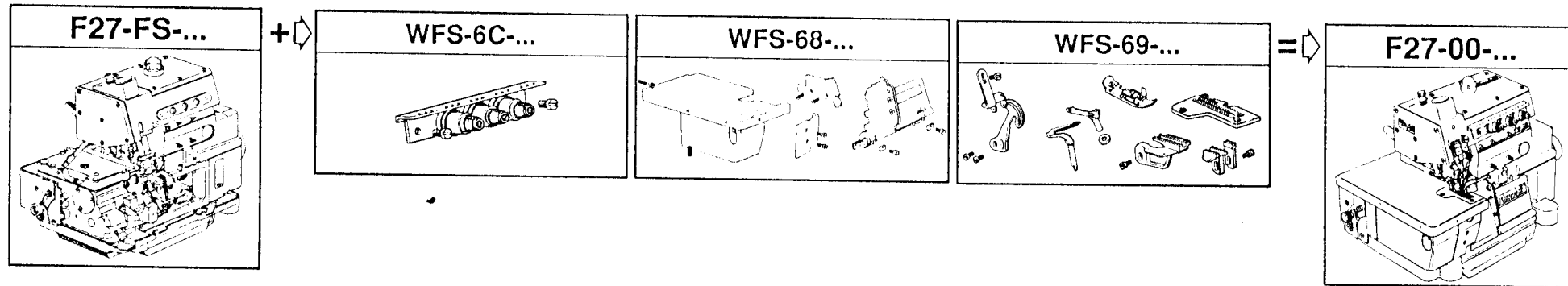
1a EDIZIONE - EDITION 1/96 **n. 695**

GUIDA PER LA CONSULTAZIONE DEL CATALOGO RICAMBI	GUIDELINES FOR THE USE OF SPARE PARTS CATALOGUE	GUIDE A LA CONSULTATION DU CATALOGUE PIECES DE RECHANGE	ANLEITUNG FÜR DIE BENUTZUNG DES ERSATZTEILKATALOGES	GUIA PARA LA CONSULTA DEL CATALOGO DE REPUESTOS
<p>Il catalogo pezzi di ricambio é costituito da due parti: la prima illustra i particolari comuni a tutte le teste; la seconda comprende i particolari specifici, riuniti in moduli.</p>	<p>The spare parts catalogue is made up of 2 sections: the first section illustrates the common parts to all heads; the second section comprises the specific ones, combined in modules.</p>	<p>Le catalogue se compose de deux parties: la première illustre les pièces communes à toutes les têtes; la seconde se réfère aux pièces spécifiques, réunies en modules.</p>	<p>Der Ersatzteilkatalog besteht aus 2 Teilen: im ersten sind die für jeden Grundnahkopf gleichen Teile eingetragen; im zweiten sind die spezifischen Teile zu finden, die Aufbaugruppen bilden.</p>	<p>El catálogo de repuestos está formado de dos partes: la primera ilustra los particulares comunes a todos los cabezales; la segunda comprende particulares específicos, agrupados en módulos.</p>
<p>La composizione della testa interessata si ottiene consultando la tabella "COMPOSIZIONE TESTE Vega".</p>	<p>The head composition is obtained by consulting the table "COMPOSITION Vega HEADS".</p>	<p>La composition de la tête intéressée s'obtient en consultant le tableau "COMPOSITION TETES Vega".</p>	<p>Die Zusammenstellung des Nähkopfes erstelle man aufgrund der Tabelle "ZUSAMMENSTELLUNG DES VEGA-NÄHKOPFES"</p>	<p>La composición del cabezal deseado, se obtiene consultando la tabla "COMPOSICION CABEZAL Vega".</p>
<p>I particolari che compongono un gruppo sono riquadrati; i sottogruppi, anch'essi riquadrati, sono inseriti nel gruppo di appartenenza.</p>	<p>The parts that are components of an assembly are represented within a square; the sub-assembly, also represented within a square, are included in the assembly they are part of.</p>	<p>Les pièces qui composent un groupe sont bordées; les sous-groupes eux mêmes bordés, sont insérés dans le groupe d'appartenance.</p>	<p>Alle Teile welche eine Teilegruppe bilden sind umrahmt; die Untergruppen, ebenfalls umrahmt, sind in der betreffenden Teilegruppe angeführt.</p>	<p>Los particulares que componen un grupo son encuadrados. Los subgrupos, aunque si son encuadrados, son inseridos en el grupo de pertenencia.</p>
<p>Tutti i particolari non fornibili sciolti non vengono richiamati singolarmente, ma soltanto illustrati nel gruppo di appartenenza.</p>	<p>All the parts which are not supplyable separately, are not described one by one, but only illustrated in the belonging group.</p>	<p>Toutes les pièces qui ne peuvent pas être fournies séparément ne sont pas rappelées individuellement mais uniquement illustrées dans le groupe d'appartenance.</p>	<p>Die nicht los lieferbaren Teile sind nicht alleine sondern immer zusammen mit der Aufbaugruppe eingetragen.</p>	<p>Todos los particulares no suministrables sueltos no estan señalados uno por uno, sino solamente ilustrados en el grupo al cual pertenecen.</p>
<p>Per facilitare la ricerca viene riportato l'indice numerico di tutti i particolari comuni a tutte le teste, illustrati nella prima parte del catalogo.</p>	<p>In order to find the pieces easily, a numerical index of the parts common to all heads is given in the first section of the catalogue.</p>	<p>Pour faciliter la recherche, dans la première partie du catalogue, on a reporté l'index numérique de toutes les pièces communes à toutes les têtes.</p>	<p>Zur Erleichterung des Aufsuchens wurde im Katalog ein Verzeichnis von allen im ersten Teil eingetragenen Teilen eingearbeitet.</p>	<p>Para facilitar el manejo figura un indice numerico de todos los particulares comunes a todos los cabezales, ilustrados en la primera parte del catalogo.</p>
<p>Per ordinare gli aghi, precisare il simbolo riportato in catalogo; in caso di dubbio allegare un ago campione o una bustina vuota.</p>	<p>When ordering needles, please specify catalogue symbol; if you have doubts, send a sample needle or an empty needle bag with your order.</p>	<p>Pour les commandes d'aiguilles, préciser le symbole indiqué sur le catalogue, en cas de doute joindre une aiguille échantillon ou un sachet vide.</p>	<p>Für Aufträge über Nähadeln ist die im Ersatzteilkatalog angeführte Teilenummer anzugeben; in Zweifelsfällen ist eine Nadel als Muster oder ein entsprechender leerer Nadelbrief beizulegen.</p>	<p>Por pedido de agujas, precisar el símbolo reproducido en el catálogo. En caso de duda, adjuntar un modelo o un sobre vacío.</p>



## CODIFICA TESTE Vega

Vega, che fa parte della filosofia produttiva **Flexsystem**, è un sistema modulare di cucitura, composto da un' **Unità-Base** e diversi **Kit di Personalizzazione**, con i quali si può ottenere la sottoclasse più idonea alle diverse operazioni di cucitura. E' possibile identificare e ordinare le teste complete oppure le Unità-Base + Kit sciolti di personalizzazione.



	Codice teste <b>TF-XX-VV-YJK-ZZ</b>	
--	--	--

**XX** = Specifica classe:

- 17 = overlock F17. Testa con estensione cilindrica al posto del piano di lavoro, per cuciture su capi tubolari.
- 27 = overlock F27. Testa con piano di lavoro normale.
- 29 = safety stitch F29.
- 20 = punto catenella F20.

**VV** = Sigla alfanumerica del codice di impiego. La sigla **FS (FLEXSYSTEM)** identifica le teste "Unità Base".

**Y** = Numero aghi.

**J** = Eccentricità sollevamento griffe così utilizzata:

- C = 0,9 mm.
- M = 1,1 mm.

**K** = Tipo di trasporto.

**ZZ** = Sigla alfanumerica dei codici sequenziali che identificano la testa specifica o la famiglia di appartenenza per le teste "Unità Base".

	Codice Kit di trasformazione e/o personalizzazione teste Vega <b>WFS-XY-ZZZ-TW-U</b>	
--	---	--

**X** = Sigla alfanumerica che identifica le classi delle teste di appartenenza del Kit, così utilizzata:

- A = Kit comuni a più classi di teste.
- 6 = Kit specifico per teste serie Vega.

**Y** = Sigla alfanumerica che identifica le classi del Kit:

- 1 = Kit puller.
- 3 = Kit rulli dosatori meccanici superiori.
- 5 = Kit attrezzature vari.
- 6 = Kit gruppo di comando.
- 8 = Kit carter.
- 9 = Kit campionatura.
- A = Kit elettronica di comando.
- B = Kit supporto porta placca e affini.
- C = Kit tensioni.
- D = Kit dispositivi.
- S = Kit dispositivi ausiliari (rulli elett. sup. e inf., Lisa, etc.).

**ZZZ** = Sigla alfanumerica per la sequenza delle classi dei Kit.

**TW-U** = Sigla alfanumerica utilizzata nel seguente modo:

a) Per tutti i Kit ad esclusione dei Kit dispositivi (seconda posizione del codice=D).

**TW-U** = Sigla alfanumerica per l'indice di modifica.

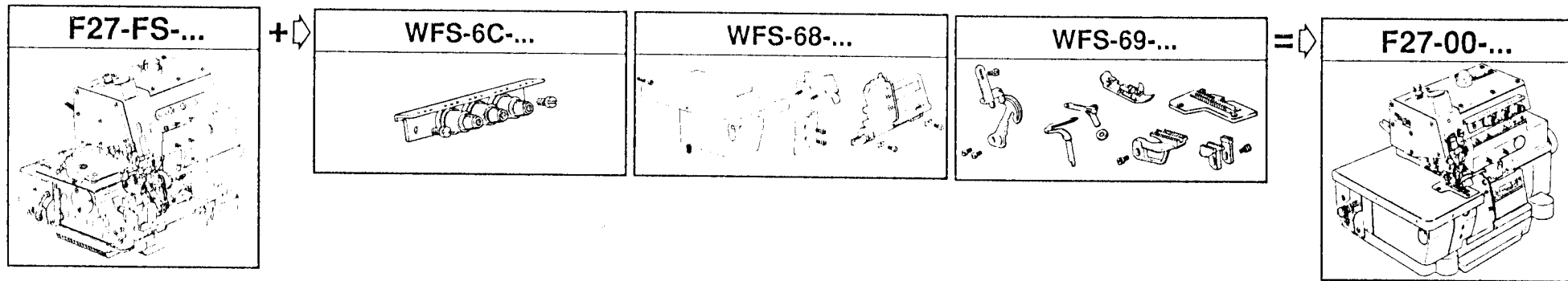
b) Per Kit dispositivi (seconda posizione del codice=D).

T = Dispositivi di base e per abbinamenti, così utilizzato:

- A = Kit elettronici.
- B = Kit di base.
- S = Kit di servizio (es. filtri).
- C = Kit per PL-MO-UP-UR.
- W = Sigla alfanumerica per dispositivi speciali.
- M = Provvisorio per usi interni.
- U = Sigla alfanumerica per indice di modifica.

## CODIFICATION OF Vega HEADS

Vega, parts of the **Flexsystem** productive philosophy, is a sewing modular system, composed by one **Unit-Base** and different **Personalizing Kits**, which allow to obtain the most suitable subclass for the different sewing operations.  
It is possible to identify and order both the complete heads and the Unit-Base + loose Personalizing Kits.



	Heads code <b>TF-XX-VV-YJK-ZZ</b>	
--	--------------------------------------	--

	Transformation and/or personalization kit code for Vega heads <b>WFS-XY-ZZZ-TW-U</b>	
--	---	--

**XX** = class specification :

- 17=overlock F17. Head with cylindric extension instead of working plate, for sewing tubulars garments.
- 27=overlock F27. Head with normal working plate.
- 29=safety stitch F29.
- 20=chain stitch F20.

**VV** = alphanumeric indication of use code. The initials **FS (FLEXSYSTEM)** identifies the heads "Base Unit".

**Y** = number of needles.

**J** = feed dog lifting eccentricity, used in the following way:

- C=0.9 mm.
- M=1.1 mm.

**K** = type of feed.

**ZZ** = alphanumeric indication of the sequential code which identifies the specific heads or family it belongs to heads "Base Unit".

**X** = alphanumeric character that identifies the class of heads the kit belongs to, used in the following way:

**Y** = alphanumeric character which identifies the class of the kit:

- 1 = Puller kit.
- 3 = upper mechanical metering roller kit.
- 5 = various tool kit.
- 6 = control assembly kit.
- 8 = cover kit.
- 9 = sampling kit.

- A = kit common to more than one class of head.
- 6 = Specific Kit for Vega class heads.

- A = electronic control kit.
- B = needle plate holder and similar kit.
- C = tension kit.
- D = device kit.
- S = auxiliary device kit (upper electronic rollers and the like, Lisa etc.).

**ZZZ** = alphanumeric character for the sequence of the class of the kit.

**TWU** = alphanumeric code used in the following way:

- a) for all kits excluding the device kits (second position of the code=D).

**TWU** = alphanumeric code for the modification index.

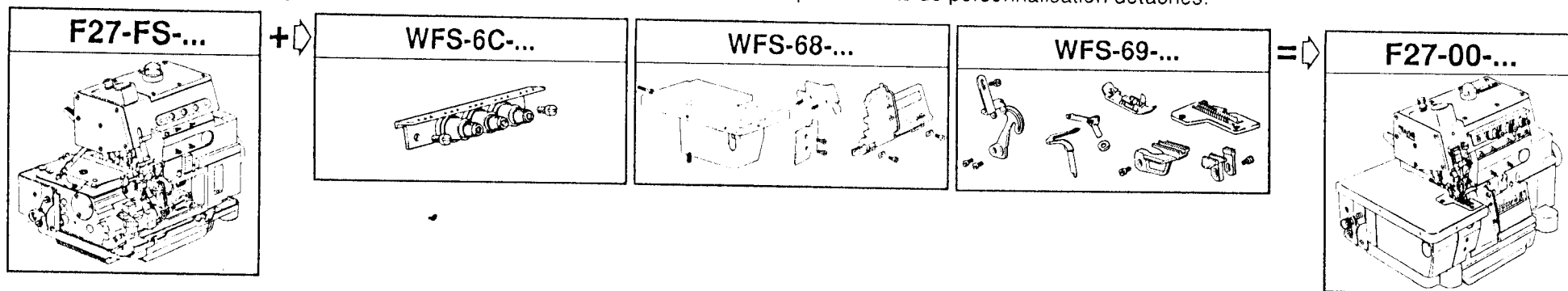
- b) for device kits (second position of the code=D).

**T** = basic kits for combination, used in the following way:

- A = electronic kit.
- B = basic kit.
- S = service kit (ex. filters).
- C = Kit for PL-MO-UP-UR.
- W = alphanumeric code for special devices.
- M = provisional for internal use.
- U = alphanumeric symbol for modification index.

## CODAGE TETES Vega

Vega, faisant partie de la philosophie productive **Flexsystem**, c'est un système modulaire de couture, composé par une **Unité-Base** et par des différents **Kits de Personnalisation**, par lesquels on peut obtenir la sous-classe la plus propre aux différents opérations de couture. Vous pouvez identifier et commander tant les têtes complètes que les Unités-Bas plus les Kits de personnalisation détachés.



	Code têtes <b>TF-XX-VV-YJK-ZZ</b>	
--	--------------------------------------	--

**XX** = spécifie classe :

- 17 = overlock F17. Tête avec extension cylindrique en remplacement du plan de travail, pour couture sur articles tubulaires.
- 27 = overlock F27. Tête avec plan de travail normal.
- 29 = safety stich F29.
- 20 = point de chaînette F20.

**VV** = sigle alphanumérique du code d'utilisation. Le sigle **FS (FLEXSYSTEM)** identifie les têtes "Unité Base".

**Y** = numéro aiguilles.

**J** = excentricité soulèvement griffes, utilisé de la manière suivante:

- C=0,9 mm.
- M=1,1 mm.

**K** = type d'entraînement.

**ZZ** = sigle alphanumérique des codes séquentiels qui identifient la tête spécifique ou la famille d'appartenance pour les têtes "Unité Base".

	Code Kit de transformation et/ou personnalisation têtes Vega <b>WFS-XY-ZZZ-TW-U</b>	
--	--	--

**X**=sigle alphanumérique qui identifie les classes des têtes d'appartenance du Kit, utilisé de la manière suivant:

- A=Kits communs à plusieurs classes de têtes.
- 6=Spécifique pour têtes series Vega.

**Y**=sigle alphanumérique qui identifie les classes du Kit:

- 1=Kit puller.
- 3=Kit rouleaux doseurs mécaniques supérieurs.
- 5=Kit équipements divers.
- 6=Kit groupes de commande.
- 8=Kit carter.
- 9=Kit échantillonnage.
- A=Kit électronique de commande.
- B=Kit support porte plaque et similaires.
- C=Kit tensions.
- D=Kit dispositifs.
- S=Kit dispositifs auxiliaires (rouleaux électr. sup. et inf., Lisa, etc.).

**ZZZ**=sigle alphanumérique pour la séquence des classes des Kits.

**TW-U**=sigle alphanumérique utilisé de la manière suivante:

a) pour tous les Kits sauf les Kits dispositifs (deuxième position du code=D).

**TW-U**= sigle alphanumérique pour l'index de modification.

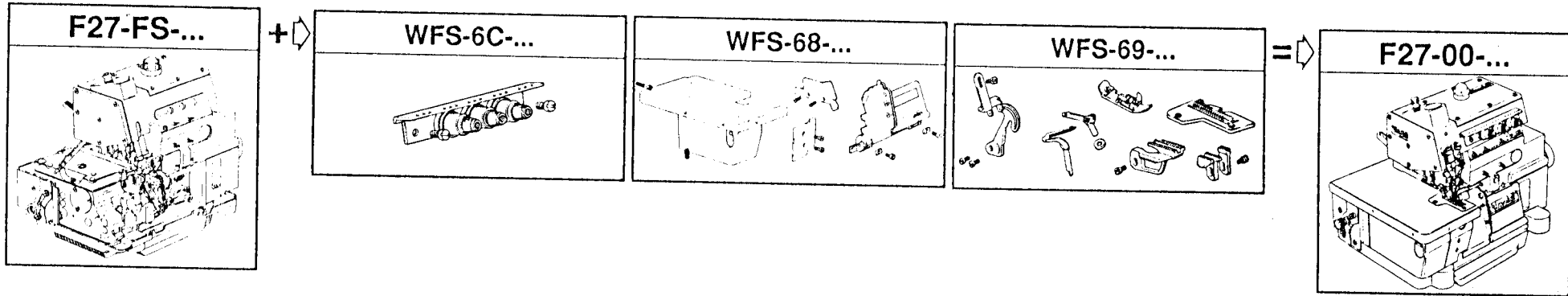
b) pour les Kits dispositifs (deuxième position du code=D).

**T**=Dispositifs de base et pour accouplements, utilisé de la manière suivante:

- A=Kits électroniques.
- B=Kit de base.
- S=Kit de service (par ex. filtres).
- C=Kit pour PL-MO-UP-UR.
- W=sigle alphanumérique pour dispositifs spéciaux.
- M=provisoire pour usages intérieurs.
- U=sigle alphanumérique pour index de modification.

## CODIFIZIERUNG DER Vega OBERTEILE

Vega, das zur Flexsystem produktiven philosophie gehört, ist ein modulierte nähsystem das von Einer Grundheit und verschiedenen Personalifizierungskit zusammengesetzt ist, die die fähigsten subklasse für die verschieder nen nähoperationen erreichen lässt. Sie können vollständige köpfe als auch die grundheit + gelöste personalifizierungskit identifizieren und bestellen.



Symbol für Oberteil  
TF-XX-VV-YJK-ZZ

Simbol Umbausatz und/oder personalisierung der Vega Oberteil  
WFS-XY-ZZZ-TW-U

**XX** = Klassenspezifikation:

- 17 = Überwendlichmaschine F17. Zylidrischer basis Oberteil statt arbeits plate, zum saeu men schlauchware.
- 27 = Überwendlichmaschine F27. Oberteil mit normaler arbeits plate.
- 29 = Sicherheitsstich F29.
- 20 = Kettenstich F20.

**VV** = Zahlensymbol des Einsatzcodex. Symbol FS (FLEXSYSTEM) welcher die "Klasse Base" angibt.

**Y** = Nadelzahl.

**J** = Exzentrizität der Transporteurlüftung, wie folgt:

- C=0,9 mm.
- M=1,1 mm.

**K** = Transportart.

**ZZ** = Zahlensymbol für Sequenzcodex, welcher die Maschinenfamilie oder den oberteil bezeichnet für "Klasse Base".

**X** = Zahlensymbol der Maschinenklasse zu welcher der Umbausatz gehört, wie folgt:

- A = Umbausätze für mehrere Maschinenklassen.
- 6 = Spezielle Kit für Vega oberteile.

**Y** = Zahlensymbol, welcher die Klassen des Umbausatzes (Kit) angibt:

- 1 = Kit Puller.
- 3 = Kit mech. obere Dosierungsrollen.
- 5 = Kit für verschiedene Ausrüstungen.
- 6 = Kit für Steuergruppen.
- 8 = Kit für Gehäuse.
- 9 = Kit für Einnähen.
- A = Kit elektronische Steuerung.
- B = Kit Stichplattenhalter usw.
- C = Kit für Spannungen.
- D = Kit für Vorrichtungen.
- S = Hilfsvorrichtungen (obere und untere elektr. Walzen, Lisa, usw.).

**ZZZ** = Zahlensymbol für die Klassensequenz der Umbausätze.

**TW-U** = Zahlensymbol wie folgt:

a) für alle Umbausätze ausser für Kit Vorrichtungen (zweiter Symbol=D).  
TW-U = Zahlensymbol für Umbau-Index.

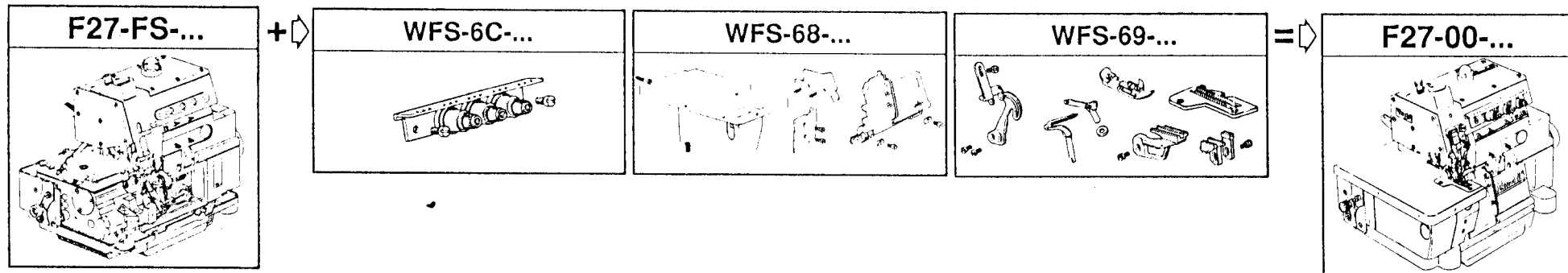
b) Kit für Vorrichtungen (zweiter Symbol=D).

T = Base-Vorrichtungen und für Kupplungen, wie folgt:

- A = elektronische Kit.
- B = Base Kit.
- S = Service Kit (z.B. Filter).
- C = Kit für PL-MO-UP-UR.
- W = Zahlensymbol für Sondervorrichtungen.
- M = provisorisch für interne Zwecke.
- U = Zahlensymbol für Umbauindex.

## CODIFICACION CABEZALES Vega

Vega, que forma parte de la filosofía productiva Flexsystem, es un sistema modular de costura, compuesto por una Unidad-base y diferentes Kit de Personalización, con los cuales se puede obtener la subclase más idonea para las diferentes operaciones de costura. Es posible identificar y solicitar los cabezales completos o bien las Unidades-Base + Kit de personalización sueltos.



	Códigos cabezales TF-XX-VV-YJK-ZZ	
--	--------------------------------------	--

**XX** = especifica clase:

- 17=overlock F17. Cabezal con extensión cilíndrica en sustitución del plano de trabajo, para costuras de prendas tubulares.
- 27=overlock F27. Cabezal con puesto de trabajo normal.
- 29=safety stitch F29.
- 20=punto catenella F20.

**VV** = sigla alfanumérica del código de empleo. La sigla **FS (FLEXSYSTEM)** identifica los cabezales "Unidad Base".

**Y** = número agujas.

**J** = excentricidad levantamiento garfios, utilizada en el siguiente modo:

- C=0,9 mm.
- M=1,1 mm.

**K** = tipo de transporte.

**ZZ** = sigla alfanumérica de los códigos secuenciales que identifican los cabezales específico o la familia de pertenencia por los cabezales "Unidad Base".

	Códigos Kit de transformación y/o personalización cabezales Vega WFS-XY-ZZZ-TW-U	
--	---	--

**X** = sigla alfanumérica que identifica las clases de los cabezales de pertenencia del Kit, utilizada en el siguiente modo:

- A=Kit comunes a diferentes tipos de cabezales.
- 6=Kit específicos cabezales serie Vega.

**Y** = sigla alfanumérica que identifica las clases del Kit:

- 1 = Kit puller.
- 3 = Kit rollos dosadores mecánicos superiores.
- 5 = Kit aparatos varios.
- 6 = Kit grupos de mando.
- 8 = Kit carter.
- 9 = Kit puesta a punto.
- A = Kit electrónico de mando.
- B = Kit soporte porta placa y similares.
- C = Kit tensiones.
- D = Kit dispositivos.
- S = Kit dispositivos auxiliares (rollos electr. sup. e inf., Lisa, etc.).

**ZZZ** = sigla alfanumérica para la secuencia de las clases de los Kit.

**TW-U** = sigla alfanumérica utilizada en el siguiente modo:

- a) para todos los Kit excluyendo los Kit dispositivos (segunda posición del código=D).

**TW-U** = sigla alfanumérica para el índice de modificación.

- b) para Kit dispositivos (segunda posición del código=D).

**T** = Dispositivos de base y para combinaciones, utilizada en el siguiente modo:

- A = Kit electrónicos.
- B = Kit de base.
- S = Kit de servicio (ej. filtros).
- C = Kit para PL-MO-UP-UR.
- W = sigla alfanumérica para dispositivos especiales.
- M = provisional para usos internos.
- U = sigla alfanumérica para el índice de modificación.



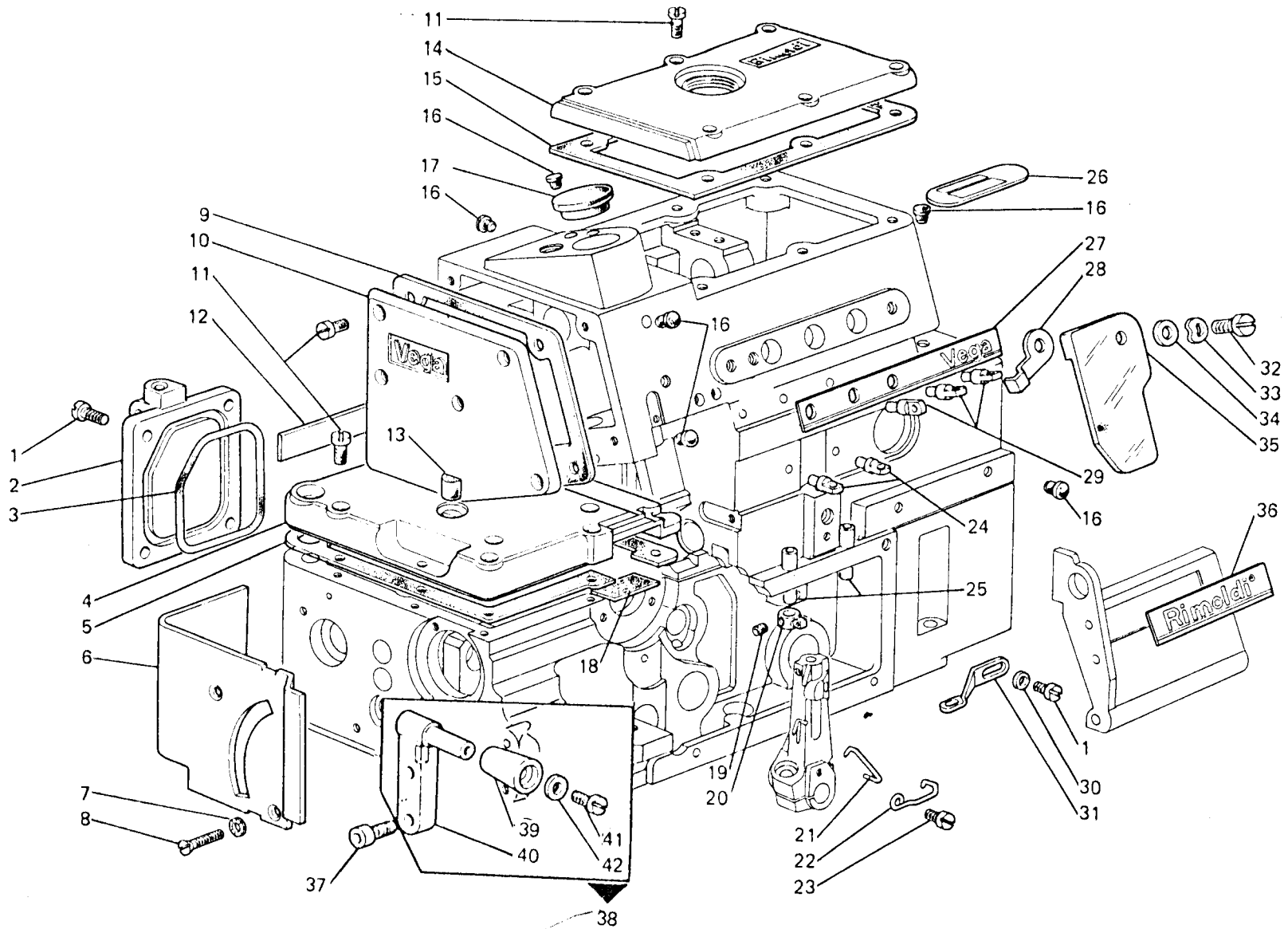


GRUPPI DI COMPOSIZIONE - COMPOSITION KITS - GROUPES DE KIT - KIT GRUPPEN - GRUPOS DE COMPOSICION

UNITA' BASE  
BASE UNIT  
UNITE DE BASE  
GRUENDLICHE EINHEIT  
UNIDAD BASE

**F27-FS-1CD-AA**

Fig. N.	Part. N. Piece N.	Qt.
1	741937-2-00	5
2	211412-0-00	1
3	701139-0-00	1
4	211418-0-00	1
5	211416-0-00	1
6	211690-0-00	1
7	703405-0-00	2
8	725032-0-00	2
9	211019-0-00	1
10	211016-0-01	1
11	741967-2-00	20
12	211056-0-00	1
13	209389-0-00	1
14	211017-0-01	1
15	211018-0-00	1
16	207893-0-00	10
17	311067-0-00	1
18	209417-0-00	1
19	745002-0-00	1
20	203135-2-10	1
21	211745-0-00	1
22	211741-0-00	1
23	741657-0-00	1
24	209760-0-00	2
25	206740-0-00	2
26	783200-0-00	1
27	211054-0-00	1
28	211020-0-00	1
29	211123-0-00	3
30	704106-2-00	1
31	211222-0-00	1
32	743547-2-00	1
33	208220-0-00	1
34	704630-0-00	1
35	209022-0-00	1
36	211055-0-00	1
37	722441-2-00	2
38	211696-4-00	1
39	211698-0-00	1
40	211699-0-00	1
41	741634-2-00	1
42	704207-2-00	1



ALBERO PRINCIPALE - MAIN SHAFT - ARBRE PRINCIPAL - HAUPTWELLE - CIGÜEÑAL PRINCIPAL

Rim<sup>®</sup> TAV. 2

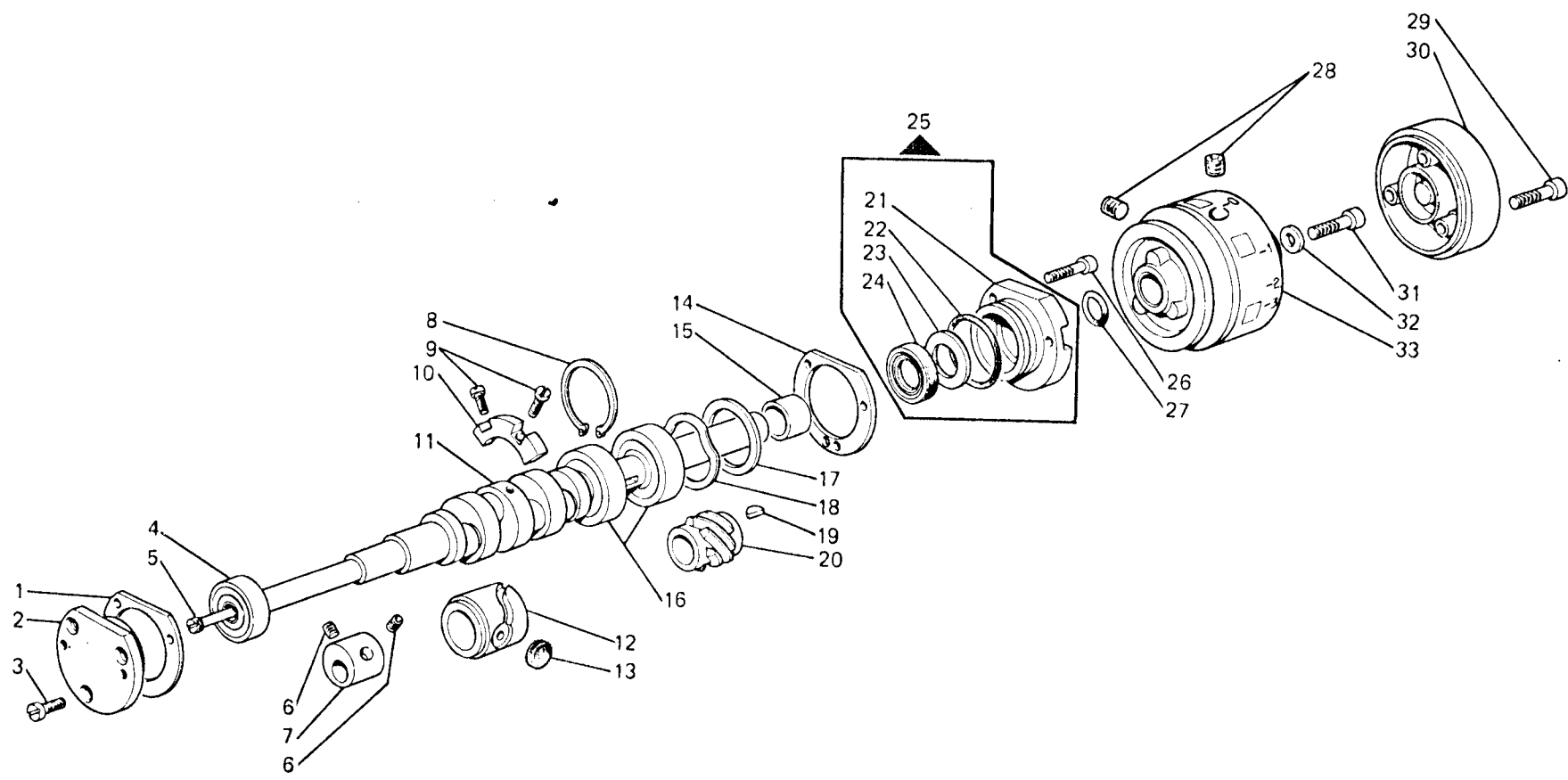
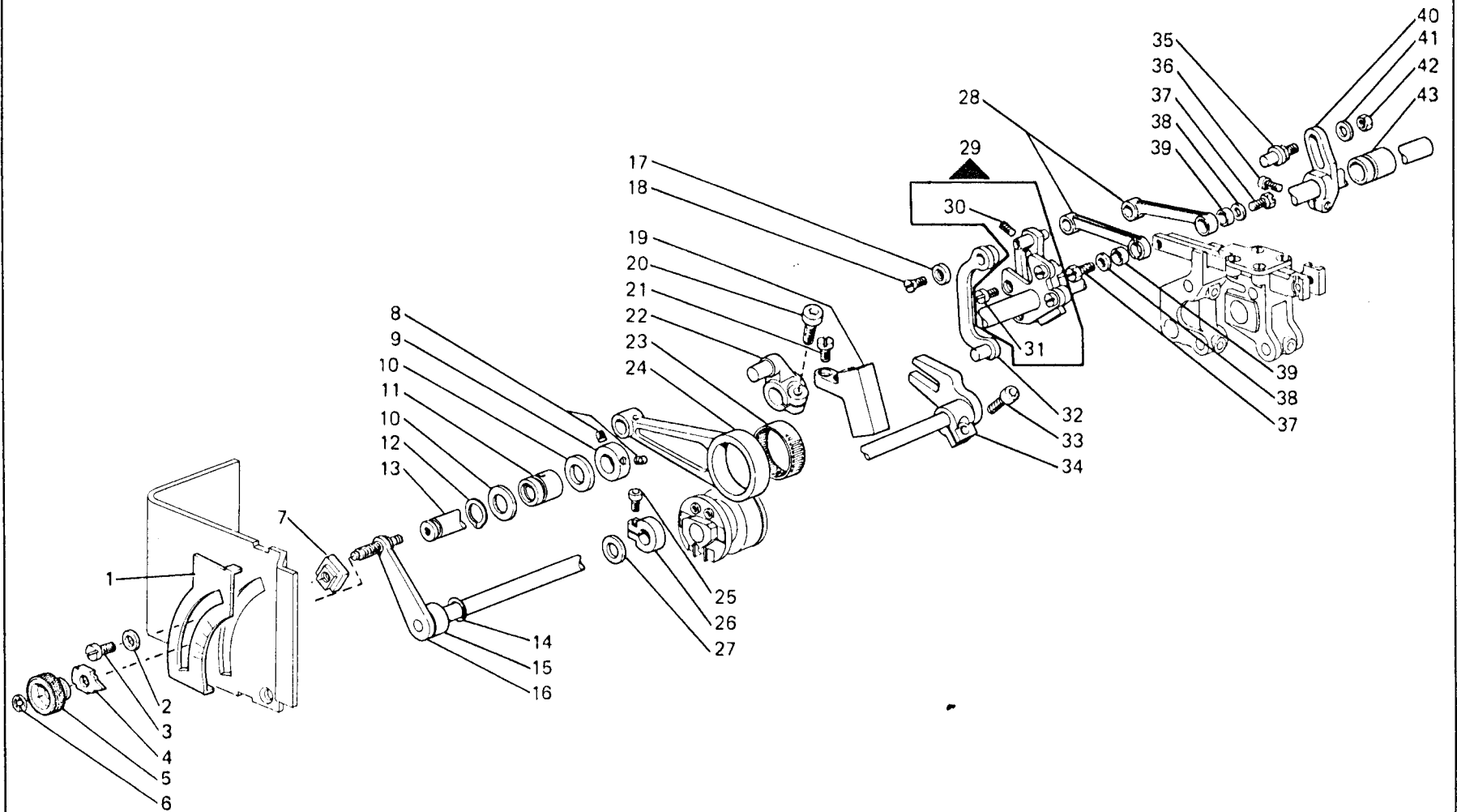


Fig. N.	Part N. Piece N.	Qt.
1	206543-0-01	1
2	206680-0-01	1
3	741956-2-00	3
4	202389-0-10	1
5	209610-0-01	1
6	745815-2-00	2
7	209144-2-00	1
8	202386-0-10	1
9	721473-2-00	2
10	209146-0-00	1
11	211100-2-00	1
12	211104-0-00	1
13	211033-0-00	1
14	209111-0-00	1
15	206692-0-00	1
16	202387-0-10	2
17	209185-0-00	1
18	206689-0-01	1
19	204122-0-10	1
20	206556-0-01	1
21	209109-0-00	1
22	701133-0-00	1
23	206693-0-00	1
24	700630-0-00	1
25	209110-4-00	1
26	722063-2-00	3
27	701116-0-00	1
28	729034-2-00	2
29	722461-2-00	3
30	211131-0-00	1
31	742675-0-00	1
32	704236-2-00	1
33	210314-0-00	1

Fig. N.	Part. N. Pecce N.	Qt.
1	209693-0-00	1
2	704409-2-00	2
3	721475-2-00	2
4	206796-0-00	1
5	206798-0-00	1
6	700207-0-00	1
7	211612-0-01	2
8	729013-2-00	2
9	313060-2-00	1
10	704853-0-00	2
11	211406-0-00	1
12	700012-0-00	1
13	211405-0-00	1
14	701007-0-00	1
15	209411-0-00	1
16	209408-2-00	1
17	207719-0-00	1
18	724032-0-00	1
19	209402-0-00	1
20	744334-2-00	1
21	741967-2-00	2
22	211382-2-00	1
23	202384-0-10	1
24	209390-0-00	1
25	741745-2-00	1
26	100620-2-10	1
27	704829-0-00	1
28	209400-0-00	2
29	211394-3-00	1
30	745827-2-00	2
31	741936-2-00	4
32	209401-2-01	1
33	722422-2-00	1
34	209403-2-00	1
35	209388-0-01	1
36	744332-2-00	1
37	202490-0-10	2
38	705208-0-00	2
39	202032-0-11	2
40	211387-2-00	1
41	704306-2-00	1
42	733806-2-00	1
43	211407-0-00	1



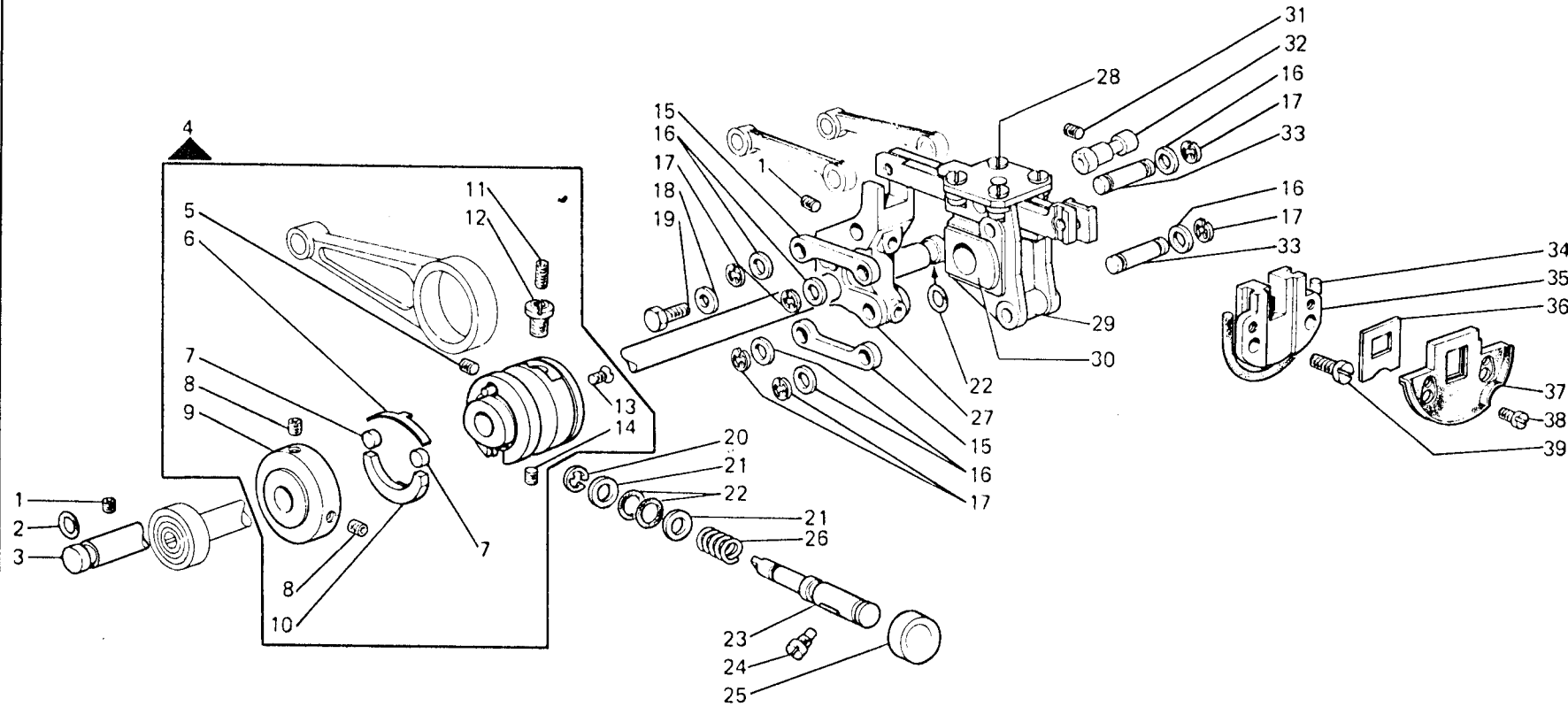
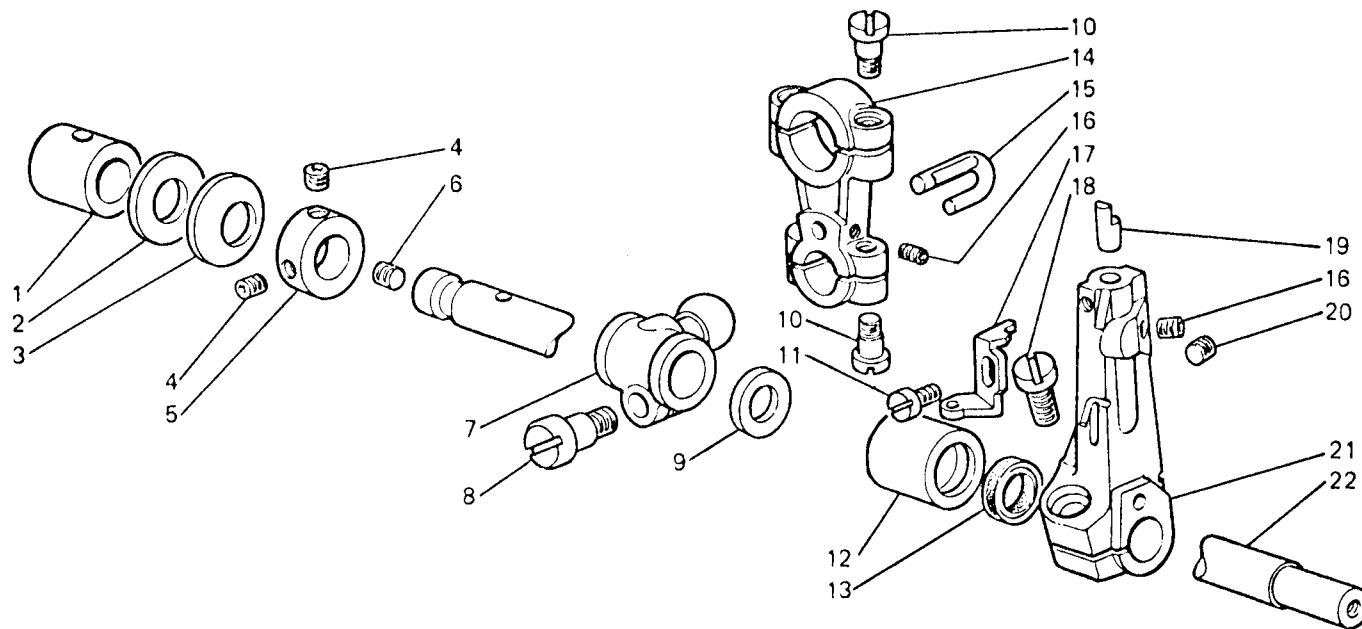


Fig. N.	Part. N. Piece N.	Qt.
1	729012-2-00	2
2	701006-0-00	1
3	211380-0-00	1
4	209448-4-11	1
5	745815-2-00	1
6	209471-0-00	1
7	209442-0-00	2
8	745812-2-00	2
9	209445-2-02	1
10	209443-0-10	1
11	729031-2-00	1
12	211444-0-00	1
13	724430-2-00	4
14	728232-0-00	1
15	209376-0-00	4
16	703802-0-00	8
17	700005-0-00	8
18	704409-2-00	1
19	740087-2-00	1
20	700208-0-00	1
21	704314-2-00	2
22	701004-0-00	3
23	209447-0-02	1
24	350555-0-00	1
25	209449-0-00	1
26	211065-0-00	1
27	209378-0-00	1
28	741936-2-00	4
29	211427-3-00	1
30	211375-0-00	1
31	729033-2-00	1
32	209379-0-00	1
33	321055-0-00	4
34	207948-0-00	1
35	211381-0-00	1
36	211385-0-00	1
37	211386-2-00	1
38	741611-2-00	2
39	722063-2-00	2
40	701005-0-00	1

Fig. N.	Part. N. Piese N.	Qt.
1	211209-0-01	1
2	705036-0-00	1
3	211281-0-00	1
4	729013-2-00	2
5	313060-2-00	1
6	727036-2-00	1
7	211224-2-00	1
8	201128-0-10	1
9	704885-0-00	1
10	722089-2-00	4
11	741415-2-00	1
12	211253-0-01	1
13	311166-0-00	1
14	209270-2-02	1
15	209272-0-00	1
16	745812-2-00	2
17	208015-0-00	1
18	721883-0-00	1
19	209258-0-00	1
20	745810-2-00	1
21	211250-2-00	1
22	211276-2-10	1



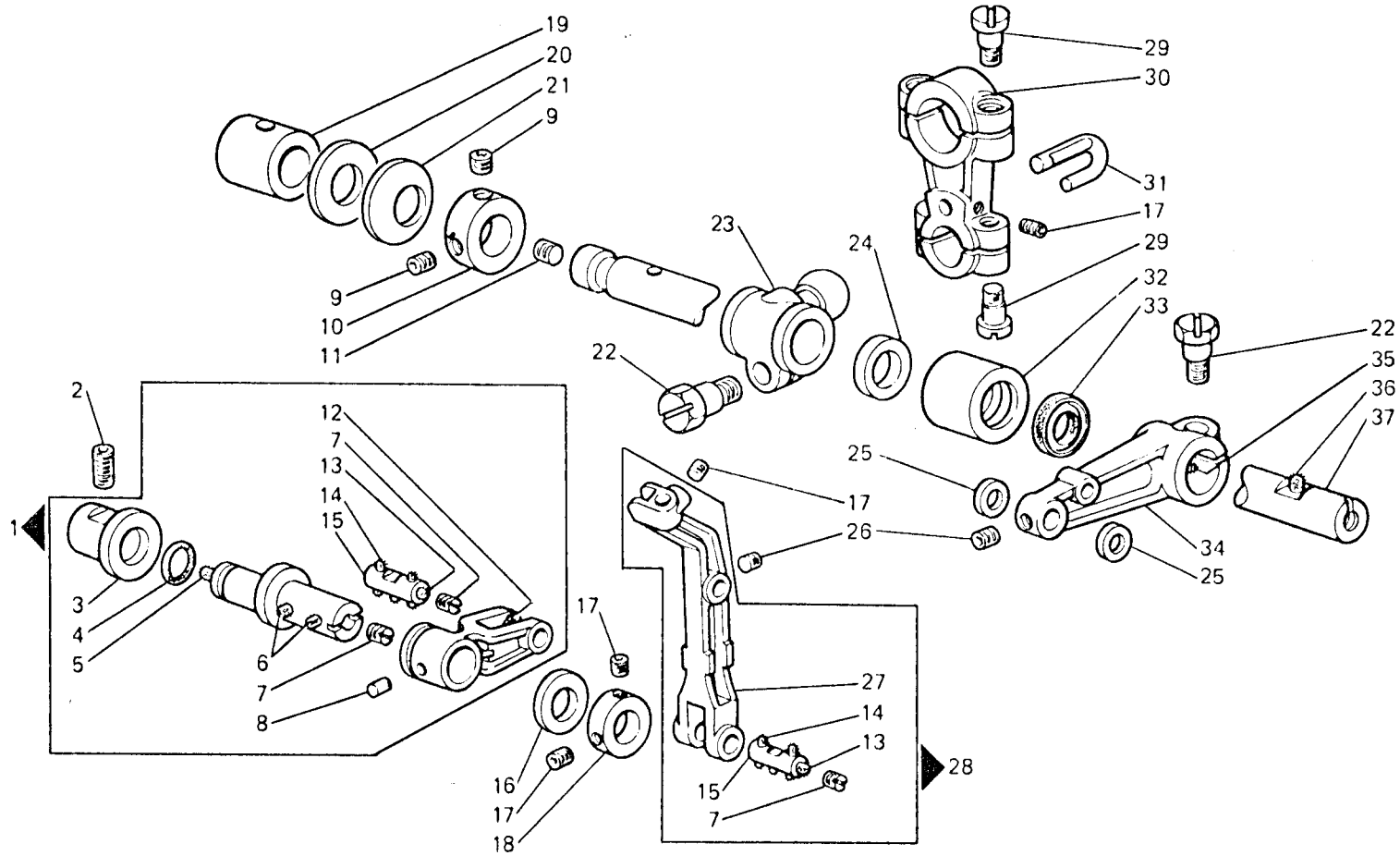
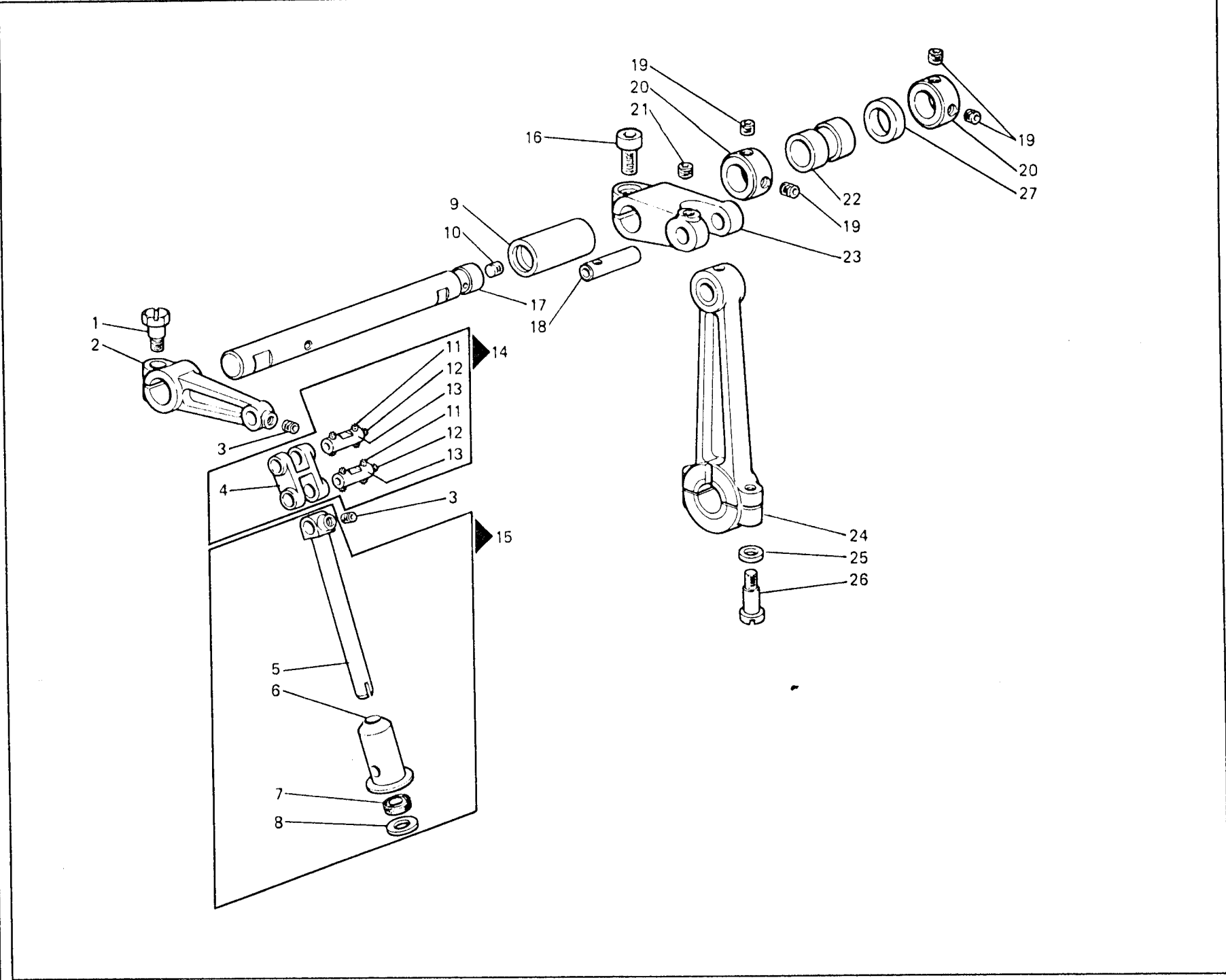


Fig. N.	Part N. Ploco N.	Qt.
1	211245-3-00	1
2	729064-2-00	1
3	211239-0-00	1
4	701005-0-00	1
5	778411-0-00	1
6	778204-0-00	4
7	745002-0-00	2
8	310724-0-00	1
9	729013-2-00	2
10	313060-2-00	1
11	727036-2-00	1
12	778503-0-00	1
13	778403-0-00	2
14	778202-0-00	10
15	211208-4-00	2
16	704873-0-00	1
17	745812-2-00	4
18	211241-2-00	1
19	211209-0-01	1
20	705036-0-00	1
21	211281-0-00	1
22	201128-0-10	2
23	211221-2-00	1
24	704882-0-00	1
25	211213-0-00	2
26	745810-2-00	2
27	211202-0-00	1
28	211254-3-00	1
29	722089-2-00	4
30	209270-2-02	1
31	209272-0-00	1
32	211253-0-01	1
33	311166-0-00	1
34	211215-2-00	1
35	778419-0-00	1
36	778208-0-00	1
37	211280-4-10	1



Fig. N.	Part. N. Piese N.	Qt.
1	201128-0-10	1
2	211115-2-00	1
3	745810-2-00	2
4	211116-0-00	1
5	211114-0-00	1
6	211112-0-00	1
7	211110-0-00	1
8	211111-0-00	1
9	211119-0-00	1
10	727036-2-00	1
11	778204-0-00	8
12	778445-0-00	2
13	211129-4-00	2
14	211132-3-00	1
15	211109-4-00	1
16	744334-2-00	1
17	211113-0-00	1
18	209143-0-01	1
19	729013-2-00	4
20	313060-2-00	2
21	730022-2-00	1
22	211117-0-00	1
23	211141-2-00	1
24	211106-2-00	1
25	704213-2-00	2
26	722149-2-00	2
27	704853-0-00	1



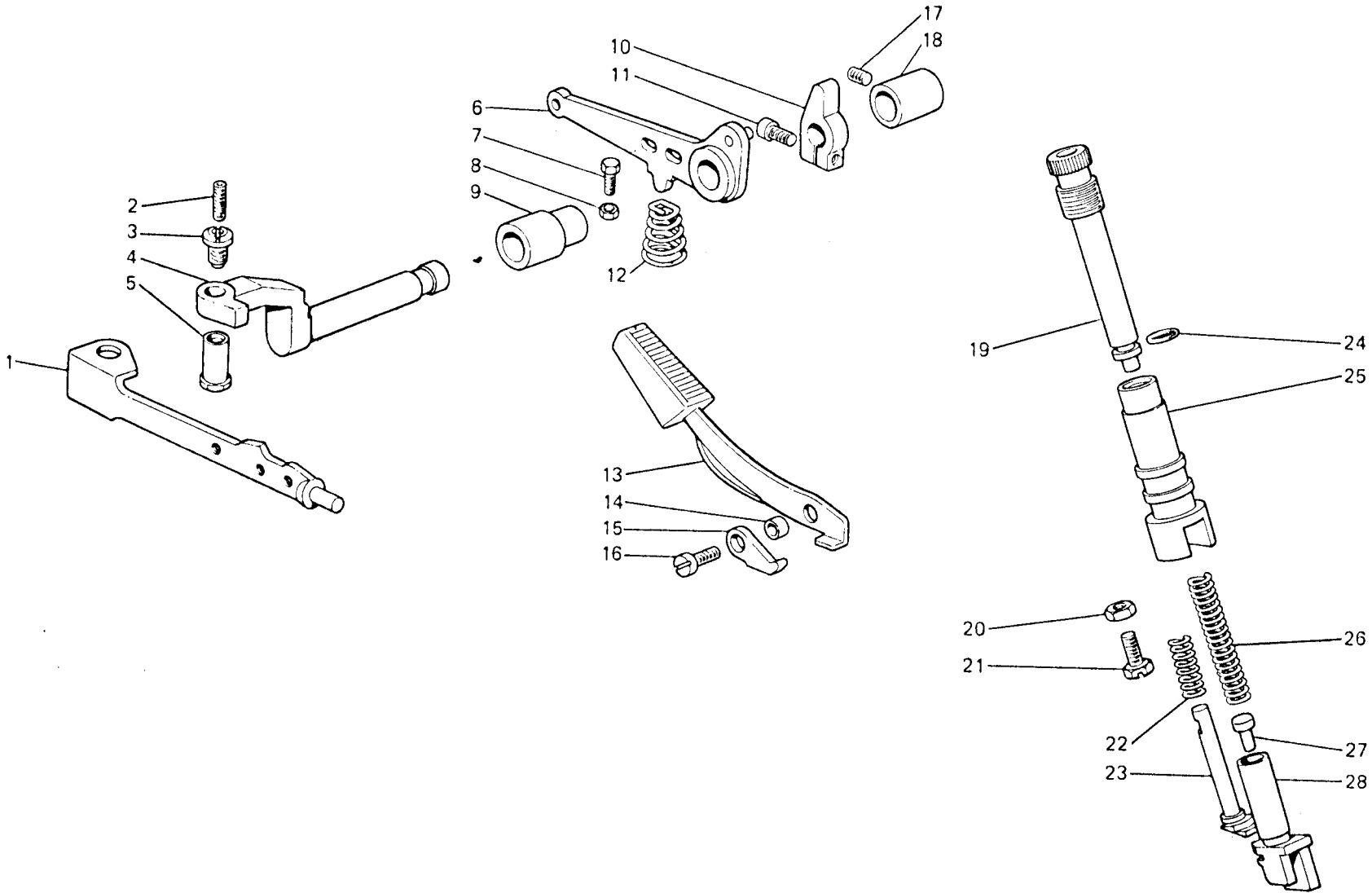
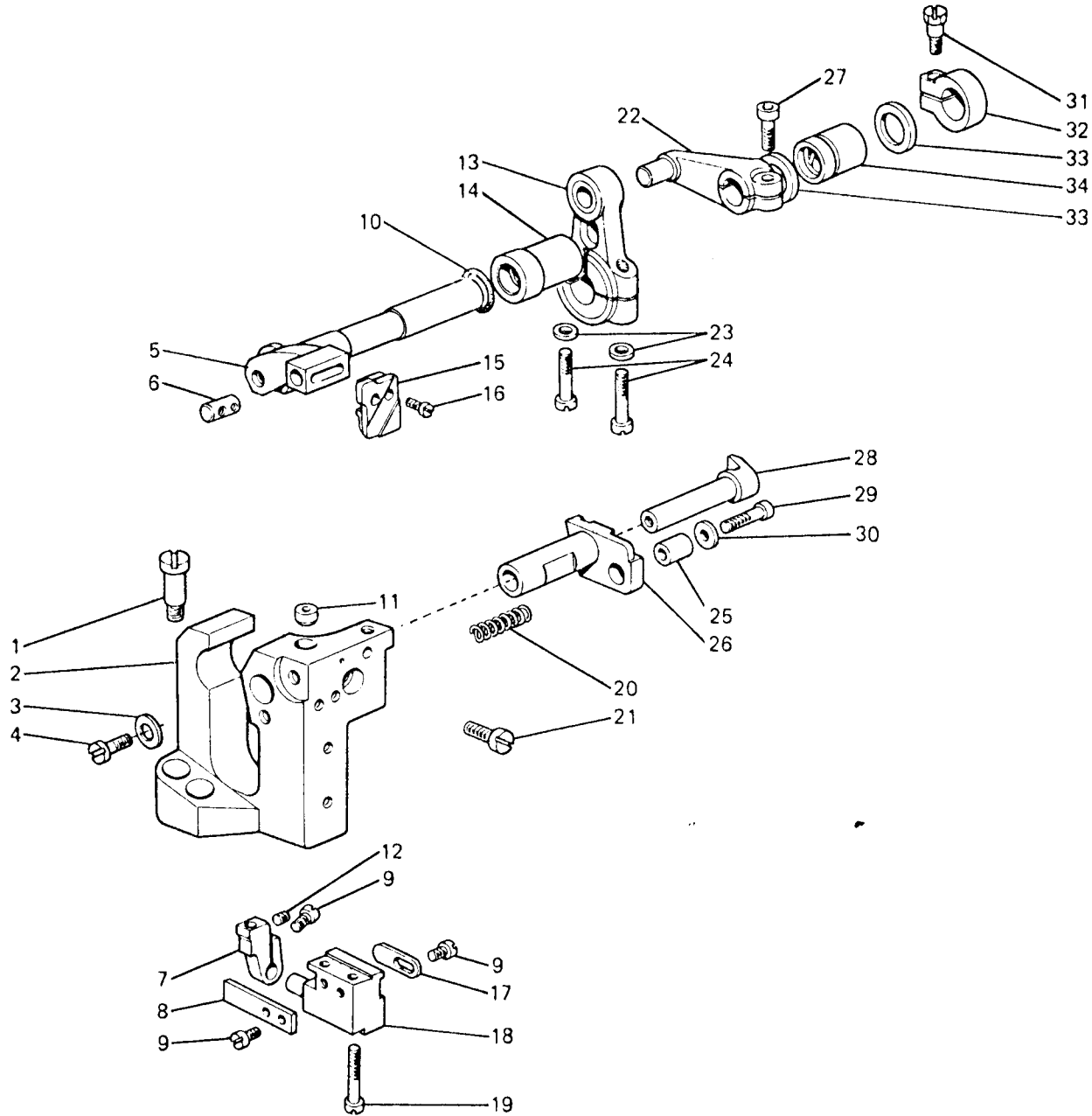


Fig. N.	Part. N. Ploco N.	Qt.
1	209510-0-00	1
2	729031-2-00	1
3	202529-0-10	1
4	209500-0-10	1
5	206622-0-00	1
6	209501-0-12	1
7	740087-2-00	1
8	746021-2-00	1
9	209503-0-10	1
10	209522-2-00	1
11	740277-2-00	1
12	209521-0-01	1
13	209524-2-00	1
14	206637-0-00	1
15	206635-0-00	1
16	722421-2-00	1
17	745812-2-00	1
18	209504-0-10	1
19	211061-0-00	1
20	746007-2-00	1
21	202214-0-11	1
22	926273-0-01	1
23	207959-0-00	1
24	701006-0-00	1
25	211060-0-00	1
26	203142-0-10	1
27	207626-0-00	1
28	207625-0-00	1

Fig. N.	Part. N. / Piece N.	Qt.
1	209587-0-00	2
2	211030-0-00	1
3	704409-2-00	1
4	742457-2-00	1
5	209561-0-01	1
6	202130-0-11	1
7	207998-2-00	1
8	207991-0-00	1
9	741552-0-00	4
10	701114-0-00	1
11	207958-0-01	1
12	745812-2-00	1
13	209569-2-02	1
14	209588-0-11	1
15	207588-0-01	1
16	744533-0-00	1
17	207999-0-00	1
18	207990-0-00	1
19	722480-2-00	2
20	202128-0-10	1
21	742758-0-00	1
22	209580-2-01	1
23	704213-2-00	2
24	722149-2-00	2
25	202129-0-10	1
26	207111-0-01	1
27	744334-2-00	1
28	202134-0-11	1
29	722471-2-00	1
30	704406-2-00	1
31	300482-0-10	1
32	209589-2-00	1
33	704863-0-00	2
34	209583-0-01	1



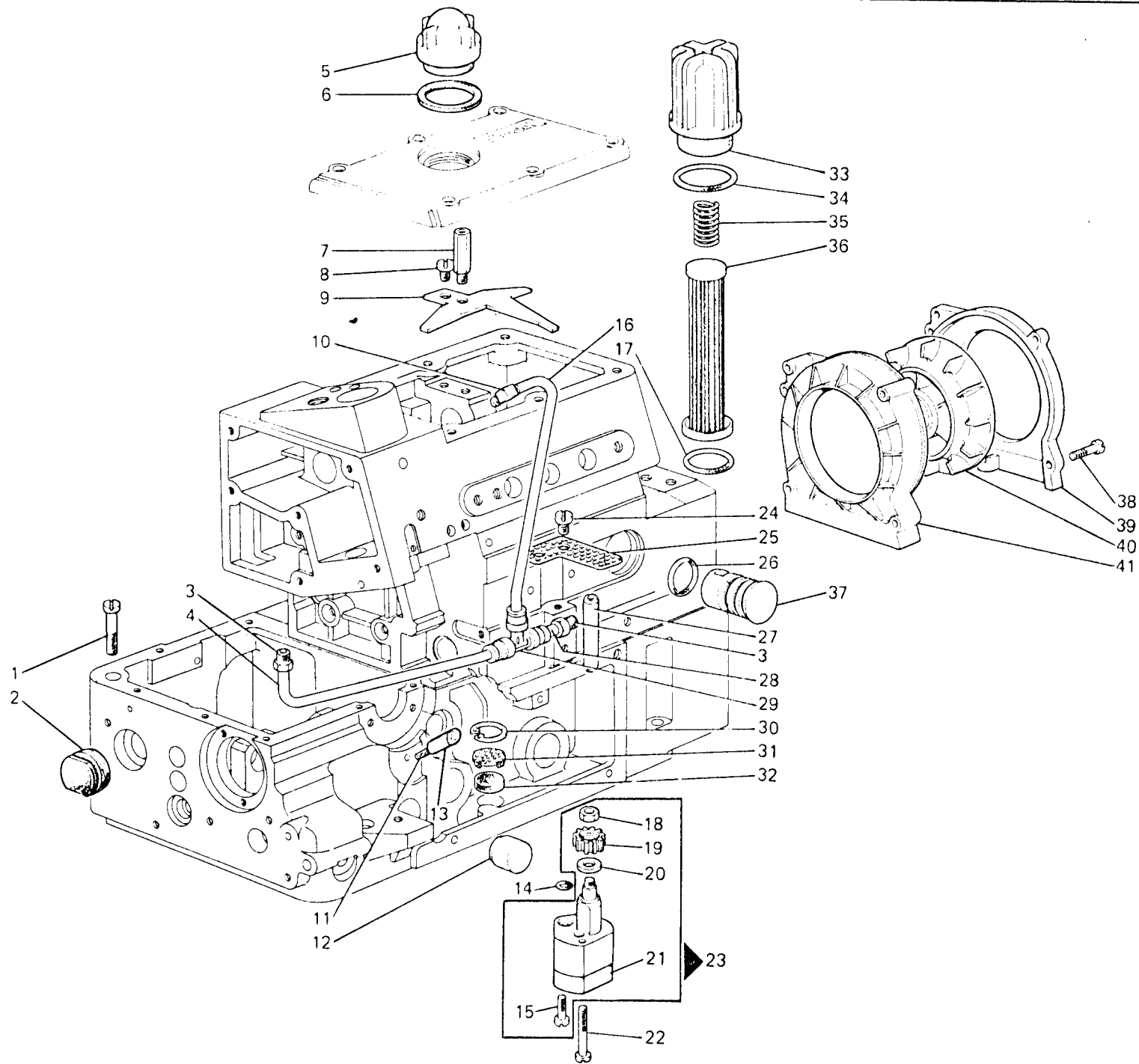


Fig. N.	Part. N. Pèce N.	Qt.
1	742086-2-00	5
2	211414-0-00	1
3	209641-0-00	2
4	790706-0-00	1
5	207973-0-01	1
6	701036-0-00	1
7	211063-0-00	1
8	741936-2-00	1
9	211062-0-00	1
10	926409-0-01	1
11	209383-0-00	1
12	209316-0-00	1
13	211211-0-00	1
14	701004-0-00	1
15	741387-2-00	2
16	790716-0-00	1
17	701123-0-00	1
18	733507-2-00	1
19	206437-0-00	1
20	704813-0-00	1
21	206554-0-10	1
22	722511-2-00	2
23	206550-4-05	1
24	741925-2-00	1
25	209633-0-00	1
26	701031-0-00	2
27	209627-0-00	1
28	790700-0-00	1
29	941538-4-00	1
30	700116-0-00	1
31	315895-0-00	1
32	211128-0-00	1
33	211053-0-01	1
34	701042-0-00	1
35	922369-0-00	1
36	211052-0-00	1
37	211051-3-00	1
38	722143-2-00	4
39	206687-2-00	1
40	206690-2-00	1
41	206688-0-00	1

Fig. N.	Part. N. Pecce N.	Qt.
1	701015-0-00	1
2	321206-0-00	1
3	209615-0-01	1
4	701006-0-00	1
5	720411-2-00	1
6	701000-0-00	1
7	209624-0-11	1
8	206665-2-00	1
9	211013-0-00	1
10	209048-3-10	1
11	211675-0-00	1

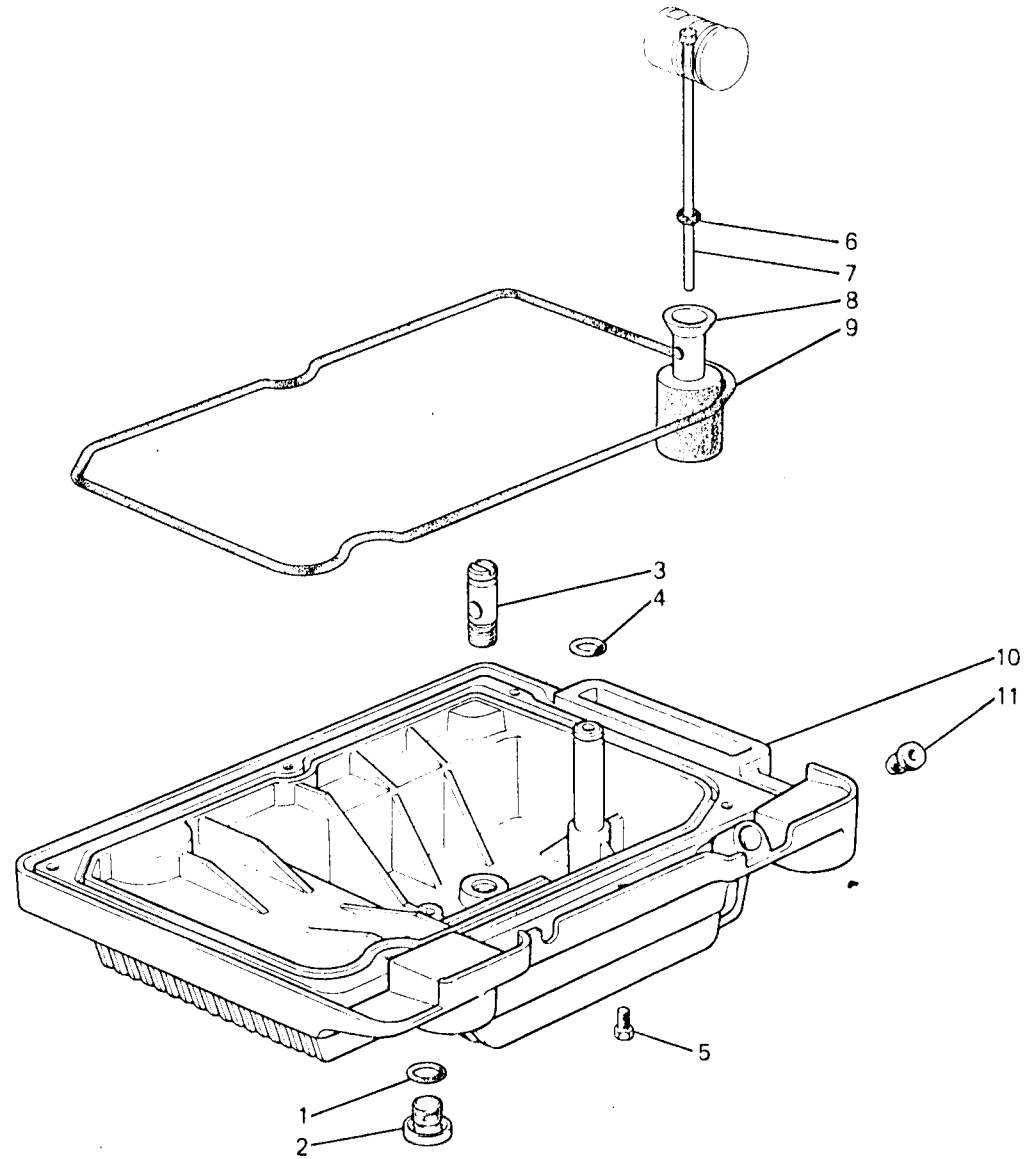


TAVOLA PER PIAZZAMENTO NORMALE  
 TABLE FOR NORMAL SETTING  
 TABLE POUR PLACEMENT NORMAL  
 SCHNITT FUER NORMAL AUFSTELLUNG  
 MESA PARA COLOCACION NORMAL

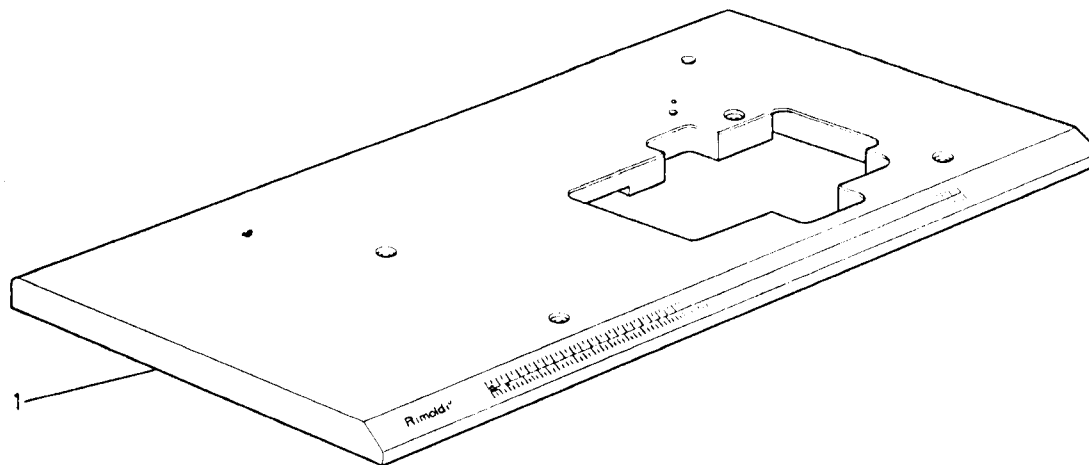


TAVOLA PER PIAZZAMENTO INCASSATO  
 TABLE FOR SUBMERGED SETTING  
 TABLE POUR PLACEMENT ENCASTRE  
 SCHNITT FUER VERSENKT AUFSTELLUNG  
 MESA PARA COLOCACION SUMERGIDA

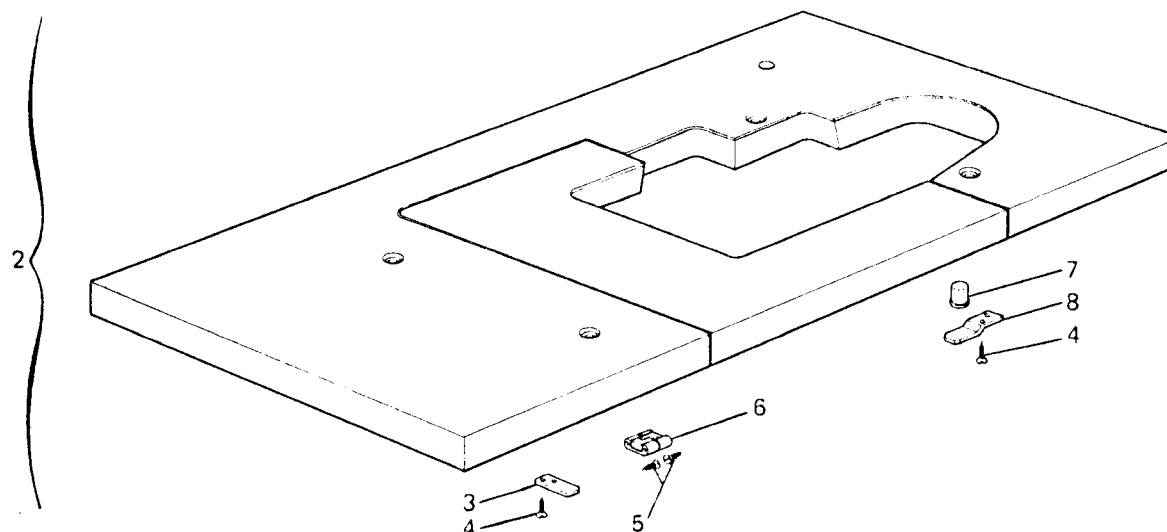
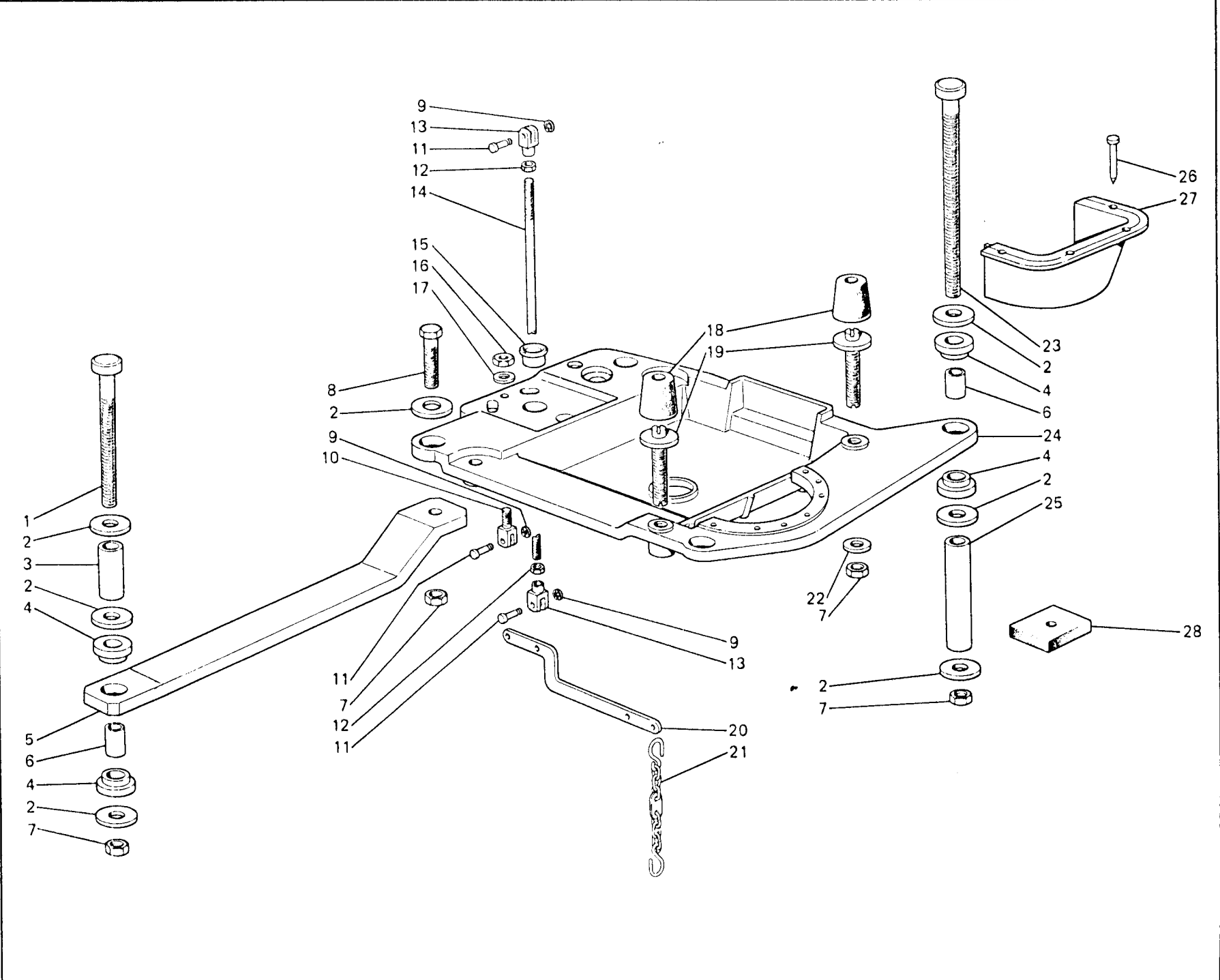


Fig. N.	Part. N. / Piece N.	Qt.
1	901112-2-01	1
2	901113-4-01	1
3	900288-0-00	1
4	732425-0-00	4
5	732429-0-00	12
6	900285-0-00	3
7	900286-0-00	1
8	900249-0-00	1

Fig. N.	Part. N. / Peça N.	Qt.
1	722912-2-00	2
2	704346-2-00	14
3	901152-0-00	2
4	901101-0-00	8
5	901151-0-00	2
6	901102-0-00	4
7	733008-2-00	10
8	720546-2-00	2
9	700205-0-00	3
10	990314-0-10	1
11	990311-0-10	3
12	746402-2-00	2
13	990310-0-10	2
14	990312-0-10	1
15	900204-0-10	1
16	746409-2-00	1
17	704424-2-00	1
18	990988-0-00	4
19	900694-0-11	4
20	991349-0-00	1
21	990179-4-11	1
22	704013-2-00	4
23	722920-2-00	2
24	991750-0-01	1
25	901153-0-00	2
26	M488972020	1
27	991187-0-01	1
28	900203-0-10	4



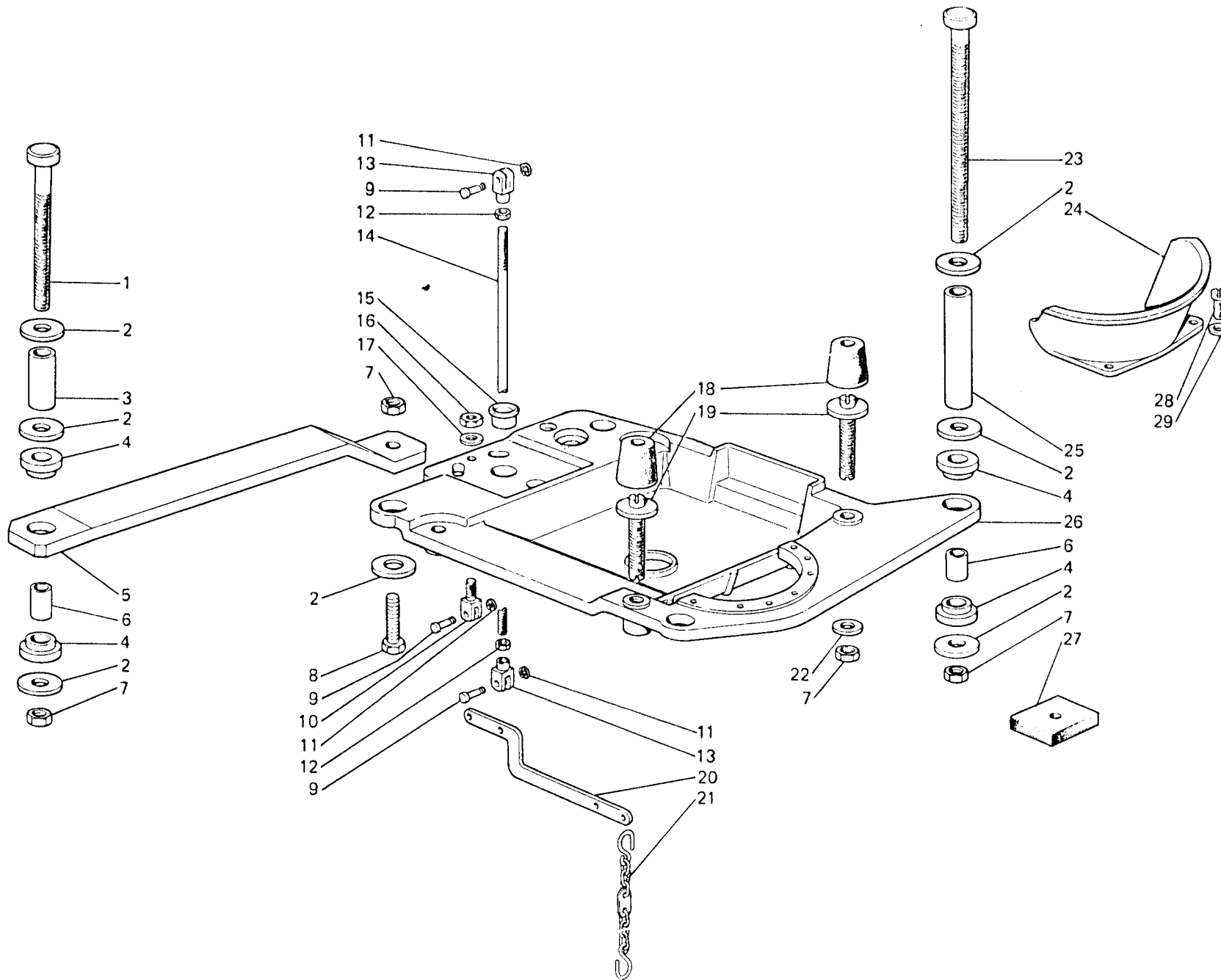


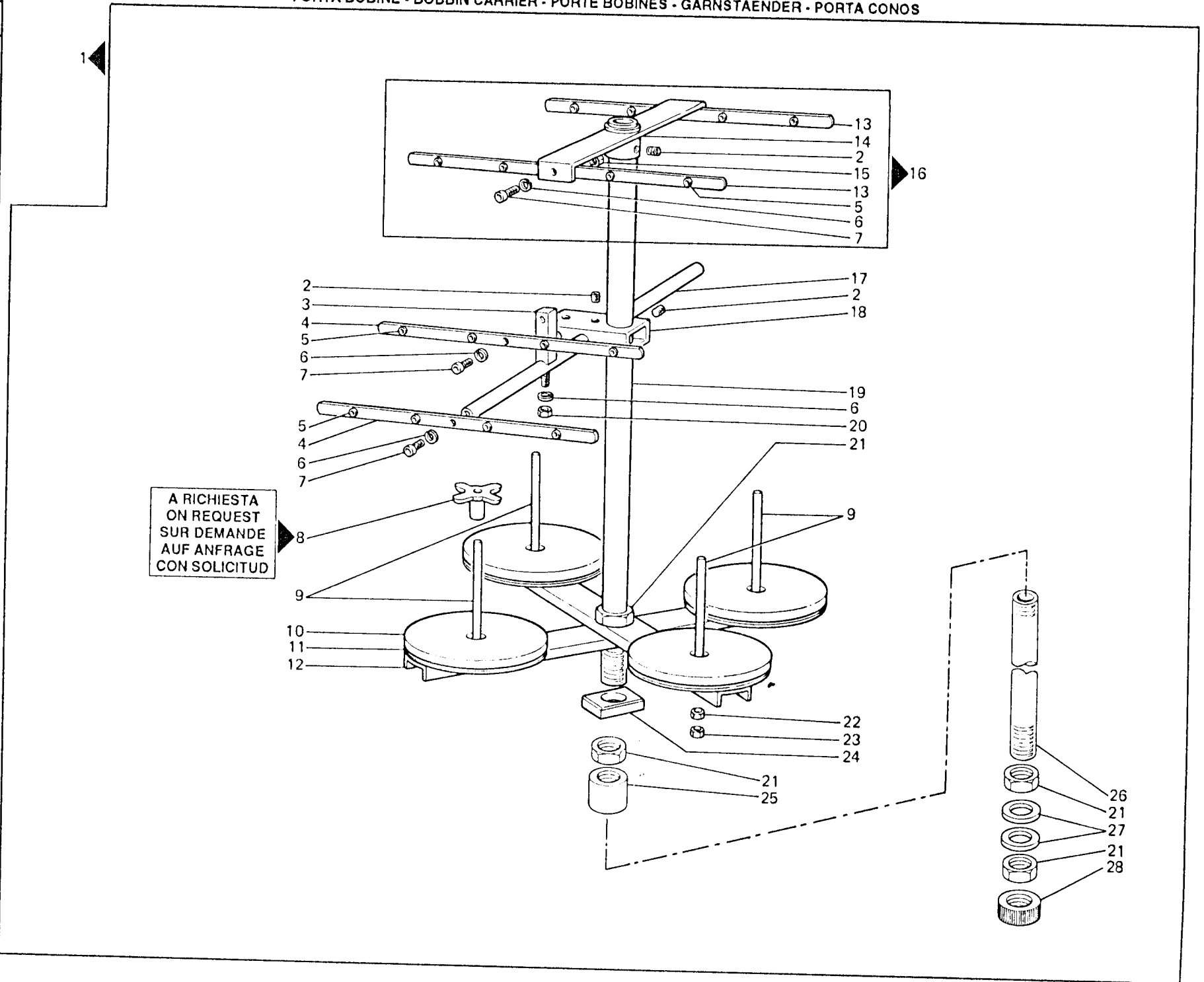
Fig. N.	Part. N. Ploca N.	Ct.
1	722912-2-00	2
2	704346-2-00	14
3	901152-0-00	2
4	901101-0-00	8
5	901151-0-00	2
6	901102-0-00	4
7	733008-2-00	10
8	720546-2-00	2
9	990311-0-10	3
10	990314-0-10	1
11	700205-0-00	3
12	746402-2-00	2
13	990310-0-10	2
14	990312-0-10	1
15	900204-0-10	1
16	746409-2-00	1
17	704424-2-00	1
18	990988-0-00	4
19	900694-0-11	4
20	991349-0-00	1
21	990179-4-11	1
22	704013-2-00	4
23	722920-2-00	2
24	991188-0-02	1
25	901153-0-00	2
26	991750-0-01	1
27	900203-0-10	4
28	721475-2-00	2
29	704409-2-00	2



# Rim® TAV. 15

## PORTA BOBINE - BOBBIN CARRIER - PORTE BOBINES - GARNSTAENDER - PORTA CONOS

Fig. N.	Part. N. Pleca N.	Qt.
1	991120-5-02	1
2	729034-2-00	3
3	991269-2-00	1
4	991108-2-01	2
5	991268-0-00	16
6	703005-0-00	5
7	722431-2-00	4
8	991134-0-00	4
9	991111-2-00	4
10	991179-0-01	4
11	991112-0-00	4
12	991199-0-00	2
13	991126-0-10	2
14	991247-2-00	1
15	733505-2-00	2
16	991194-4-00	1
17	991264-2-00	1
18	991279-2-00	1
19	991206-0-00	1
20	733806-0-00	1
21	733211-2-00	4
22	733508-2-00	4
23	925433-0-00	4
24	991172-0-00	2
25	991219-0-00	1
26	991267-0-00	1
27	704017-2-00	2
28	991383-0-10	1



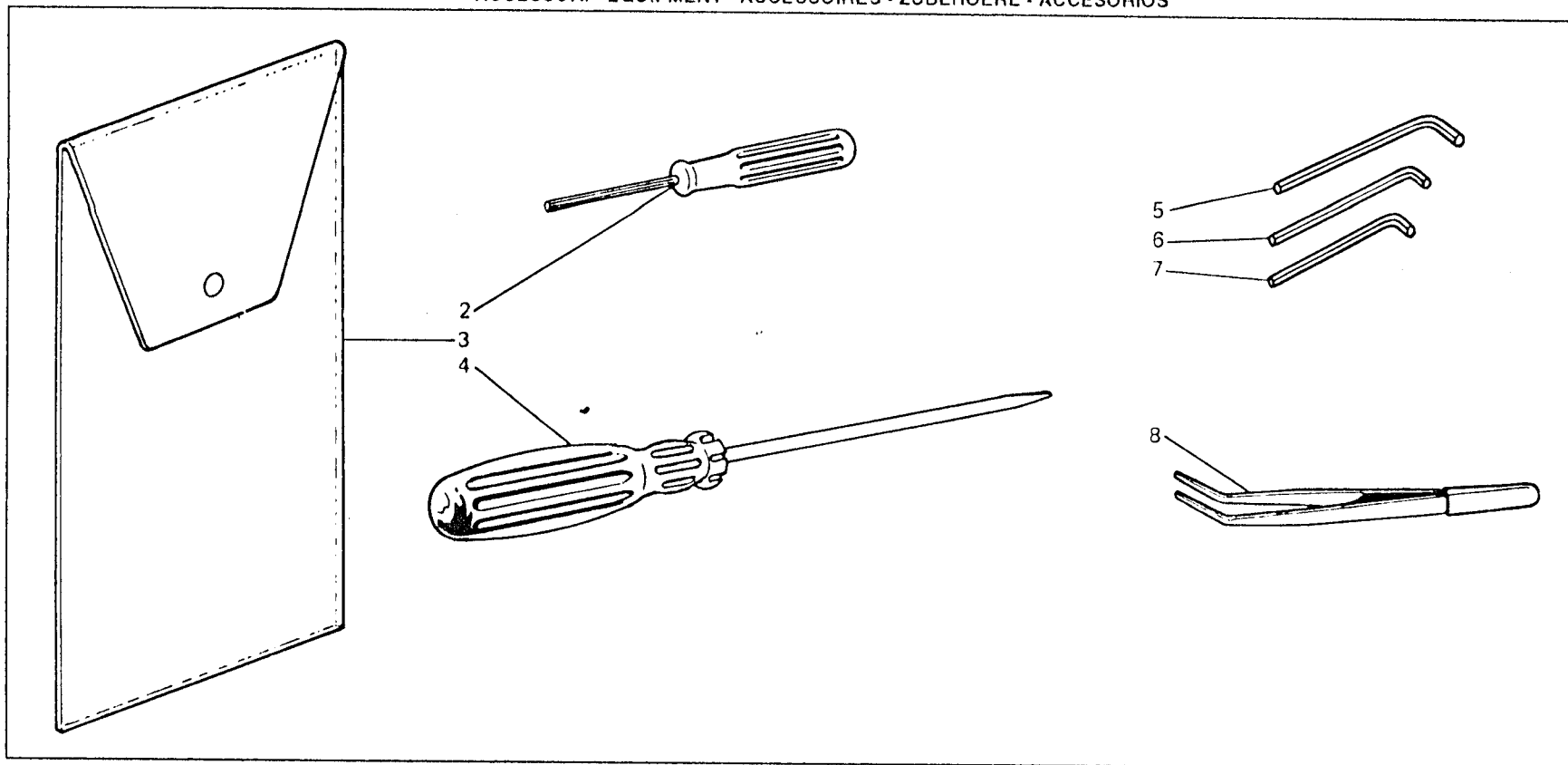
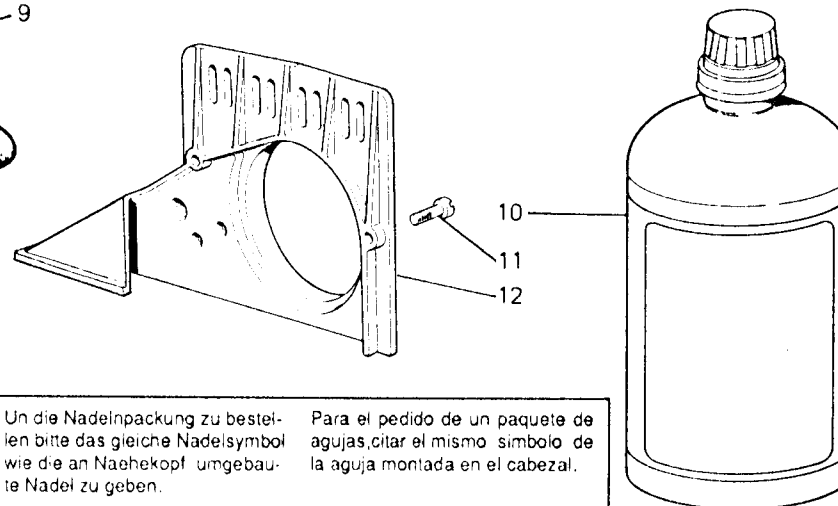
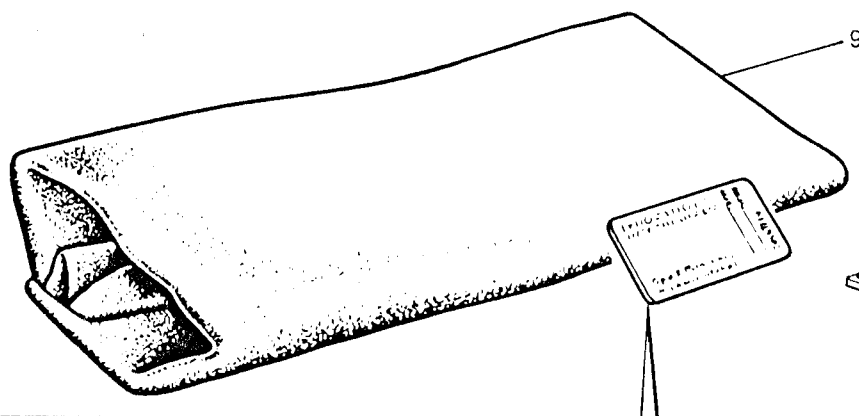


Fig. N.	Part. N. Pioco N.	Qt.
1	991400-4-03	1
2	990474-0-11	1
3	991415-0-00	1
4	990723-0-00	1
5	990639-0-10	1
6	990685-0-10	1
7	990325-0-10	1
8	990176-0-10	1
9	990979-0-00	1
10	991512-0-00	1
11	722063-2-00	2
12	209020-0-00	1



Per l'ordinazione della bustina aghi citare lo stesso simbolo dell'ago montato sulla testa.

To order packet of needles please specify symbol of needle fitted on machine.

Pour commander un sachet d'aiguilles donner le symbol de l'aiguille montée sur la tête.

Um die Nadelnpackung zu bestellen bitte das gleiche Nadelsymbol wie die an Nadelkopf umgebauten Nadel zu geben.

Para el pedido de un paquete de agujas, citar el mismo símbolo de la aguja montada en el cabezal.

## INDEX

SIMB.	TAV.	SIMB.	TAV.	SIMB.	TAV.	SIMB.	TAV.	SIMB.	TAV.	SIMB.	TAV.	SIMB.	TAV.
100620-2-10	3	207990-0-00	9	209510-0-00	8	211113-0-00	7	211444-0-00	4	704314-2-00	4	732425-0-00	12
201128-0-10	6-7	207991-0-00	9	209521-0-01	8	211114-0-00	7	211612-0-01	3	704346-2-00	13-14	732429-0-00	12
202032-0-11	3	207998-2-00	9	209522-2-00	8	211115-2-00	7	211675-0-00	11	704406-2-00	9	733008-2-00	13-14
202128-0-10	9	207999-0-00	9	209524-2-00	8	211116-0-00	7	211690-0-00	1	704409-2-00	3-4-9-14	733211-2-00	15
202129-0-10	9	208015-0-00	5	209561-0-01	9	211117-0-00	7	211741-0-00	1	704424-2-00	13-14	733505-2-00	15
202130-0-11	9	208220-0-00	1	209569-2-02	9	211119-0-00	7	211745-0-00	1	704630-0-00	1	733507-2-00	10
202134-0-11	9	209020-0-00	16	209580-2-01	9	211123-0-00	1	300482-0-10	9	704813-0-00	10	733508-2-00	15
202214-0-11	8	209022-0-00	1	209583-0-01	9	211128-0-00	10	310724-0-00	6	704829-0-00	3	733806-0-00	15
202384-0-10	3	209048-3-10	11	209587-0-00	9	211129-4-00	7	311067-0-00	1	704853-0-00	3-7	733806-2-00	3
202386-0-10	2	209109-0-00	2	209588-0-11	9	211131-0-00	2	311166-0-00	5-6	704863-0-00	9	740087-2-00	4-8
202408-0-10	4	209110-4-00	2	209589-2-00	9	211132-3-00	7	313060-2-00	3-5-6-7	704873-0-00	6	740277-2-00	8
202490-0-10	3	209111-0-00	2	209610-0-01	2	211141-2-00	7	315895-0-00	10	704885-0-00	5	741387-2-00	10
202529-0-10	8	209143-0-01	7	209615-0-01	11	211202-0-00	6	321055-0-00	4	705036-0-00	5-6	741415-2-00	5
203135-2-10	1	209144-2-00	2	209624-0-11	11	211208-4-00	6	321206-0-00	11	705208-0-00	3	741552-0-00	9
203142-0-10	8	209146-0-00	2	209627-0-00	10	211209-0-01	5-6	350555-0-00	4	720411-2-00	11	741611-2-00	4
204122-0-10	2	209185-0-00	2	209633-0-00	10	211211-0-00	10	700005-0-00	4	720456-2-00	13	741657-0-00	1
206437-0-00	10	209258-0-00	5	209641-0-00	10	211213-0-00	6	700012-0-00	3	720546-2-00	14	741745-2-00	3
206543-0-01	2	209270-2-02	5-6	209693-0-00	3	211215-2-00	6	700116-0-00	10	721473-2-00	2	741925-2-00	10
206550-4-05	10	209272-0-00	5-6	209760-0-00	1	211221-2-00	6	700205-0-00	13-14	721475-2-00	3-14	741936-2-00	3-4-10
206554-0-10	10	209316-0-00	10	211013-0-00	11	211222-0-00	1	700207-0-00	3	721883-0-00	5	741937-2-00	1
206556-0-01	2	209376-0-00	4	210314-0-00	2	211224-2-00	5	700208-0-00	4	722063-2-00	2-4-16	741956-2-00	2
206622-0-00	8	209378-0-00	4	211016-0-01	1	211239-0-00	6	700630-0-00	2	722089-2-00	5-6	741967-2-00	1-3
206635-0-00	8	209379-0-00	4	211017-0-01	1	211241-2-00	6	701000-0-00	11	722143-2-00	10	742086-2-00	10
206637-0-00	8	209383-0-00	10	211018-0-00	1	211245-3-00	6	701004-0-00	4-10	722149-2-00	7-9	742457-2-00	9
206665-2-00	11	209388-0-01	3	211019-0-00	1	211250-2-00	5	701005-0-00	6	722421-2-00	8	742675-0-00	2
206680-0-01	2	209389-0-00	1	211020-0-00	1	211253-0-01	5-6	701006-0-00	4-8-11	722422-2-00	3	742758-0-00	9
206687-2-00	10	209390-0-00	3	211030-0-00	9	211254-3-00	6	701007-0-00	3	722431-2-00	15	743547-2-00	1
206688-0-00	10	209400-0-00	3	211033-0-00	2	211276-2-10	5	701015-0-00	11	722461-2-00	2	744332-2-00	3
206689-0-01	2	209401-2-01	3	211051-3-00	10	211280-4-10	6	701031-0-00	10	722471-2-00	9	744334-2-00	3
206690-2-00	10	209402-0-00	3	211052-0-00	10	211281-0-00	5-6	701036-0-00	10	722480-2-00	9	744533-0-00	9
206692-0-00	2	209403-2-00	3	211053-0-01	10	211375-0-00	4	701042-0-00	10	722511-2-00	10	745002-0-00	1-6
206693-0-00	2	209408-2-00	3	211054-0-00	1	211380-0-00	4	701114-0-00	9	722912-2-00	13-14	745810-2-00	5-6-7
206740-0-00	1	209411-0-00	3	211055-0-00	1	211381-0-00	4	701116-0-00	2	722920-2-00	13-14	745812-2-00	4-5-6-8-9
206796-0-00	3	209417-0-00	1	211056-0-00	1	211382-2-00	3	701123-0-00	10	724032-0-00	3	745815-2-00	2-4
206798-0-00	3	209442-0-00	4	211060-0-00	8	211385-0-00	4	701133-0-00	2	724430-2-00	4	745827-2-00	3
207111-0-01	9	209443-0-10	4	211061-0-00	8	211386-2-00	4	701139-0-00	1	725032-0-00	1	746007-2-00	8
207588-0-01	9	209445-2-02	4	211062-0-00	10	211387-2-00	3	703005-0-00	15	727036-2-00	5-6-7	746021-2-00	8
207625-0-00	8	209447-0-02	4	211063-0-00	10	211394-3-00	3	703405-0-00	1	728232-0-00	4	746402-2-00	13-14
207626-0-00	8	209448-4-11	4	211100-2-00	2	211405-0-00	3	703802-0-00	4	729012-2-00	4	746409-2-00	13-14
207719-0-00	3	209449-0-00	4	211104-0-00	2	211406-0-00	3	704013-2-00	13-14	729013-2-00	3-5-6-7	778202-0-00	6
207893-0-00	1	209471-0-00	4	211106-2-00	7	211407-0-00	3	704017-2-00	15	729031-2-00	4-8	778204-0-00	6-7
207948-0-00	4	209500-0-10	8	211109-4-00	7	211412-0-00	1	704106-2-00	1	729033-2-00	4	778208-0-00	6
207958-0-01	9	209501-0-12	8	211110-0-00	7	211414-0-00	10	704213-2-00	7-9	729034-2-00	2-15	778403-0-00	6
207959-0-00	8	209503-0-10	8	211111-0-00	7	211416-0-00	1	704236-2-00	2	729064-2-00	6	778411-0-00	6
207973-0-01	10	209504-0-10	8	211112-0-00	7	211427-3-00	4	704306-2-00	3	730022-2-00	7	778419-0-00	6



GRUPPI DI COMPOSIZIONE - COMPOSITION KITS - GROUPES DE KIT - KIT GRUPPEN - GRUPOS DE COMPOSICION

RULLI  
ROLLERS  
ROULEAUX  
DOSIERUNGSWALZE  
RODILLOS

**WFS-63**

WFS-63-001-00-0

Rim®

1

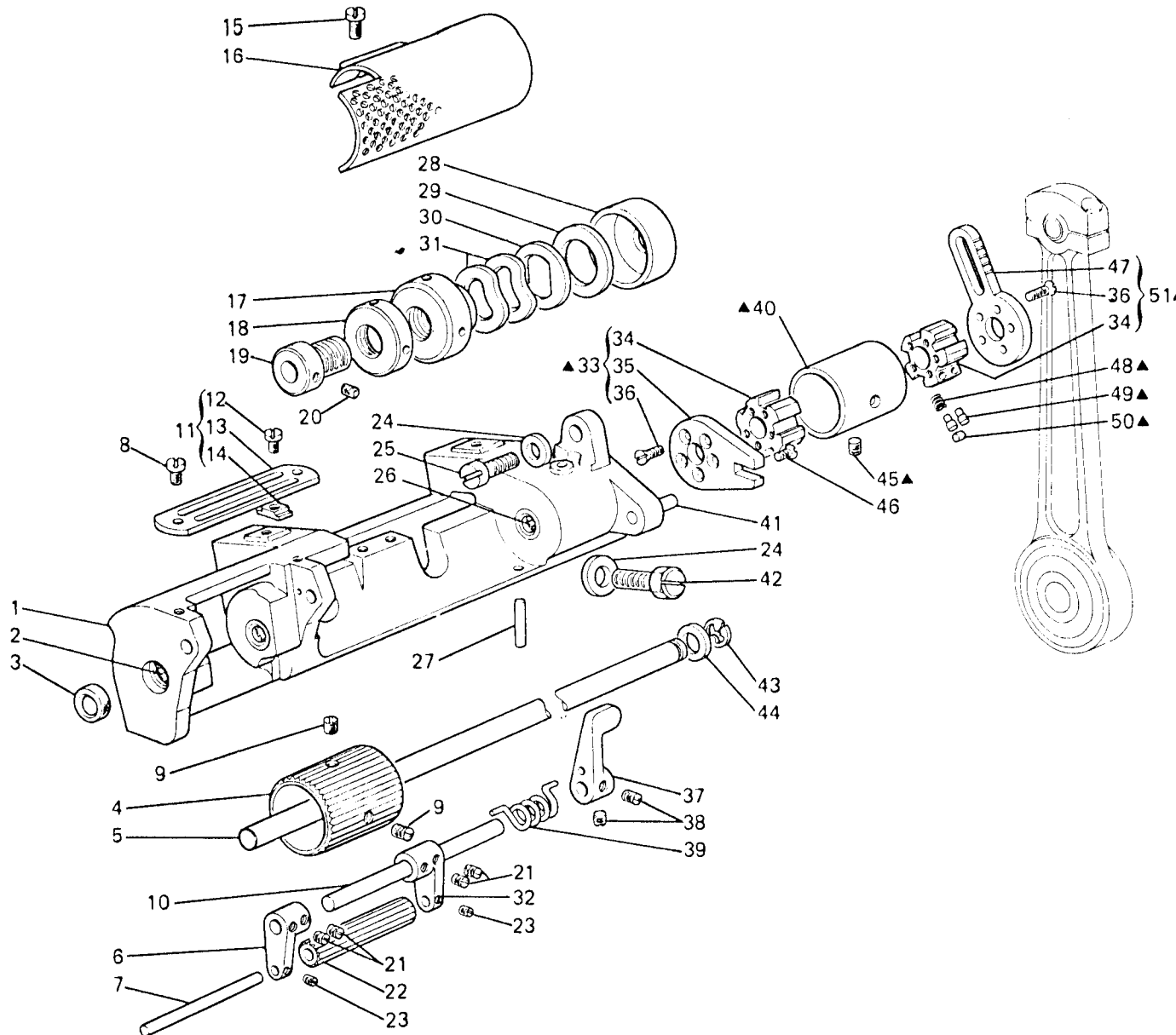


Fig. N.	Part. N. Piece N.	Qt.
	304431-4-15	1
1	211893-2-00	1
2	307739-0-00	2
3	307651-0-00	4
4	208341-2-00	1
5	211894-0-00	1
6	304438-2-10	1
7	208235-0-00	1
8	721412-2-00	2
9	729053-2-00	2
10	208234-0-00	1
11	208233-4-00	1
12	741403-0-00	4
13	208232-0-00	1
14	203949-0-10	4
15	741936-2-00	2
16	211896-0-00	1
17	208248-0-00	1
18	208246-0-00	1
19	208249-2-00	1
20	730022-2-00	1
21	727014-2-00	4
22	208342-2-00	1
23	745002-0-00	2
24	704226-2-00	3
25	721516-2-00	1
26	207103-0-00	2
27	207253-0-00	1
28	208247-0-00	1
29	208245-0-00	1
30	208244-0-00	1
31	208231-0-00	2
32	304437-2-10	1
33	304432-4-21	1
34	304589-0-01	2
35	303928-0-21	1
36	724460-0-00	10
37	304424-2-10	1
38	745812-2-00	2
39	304441-0-10	1
40	304430-0-10	1
41	304482-0-00	1
42	211898-0-00	2
43	700212-0-00	1
44	704838-0-00	1
45	729043-2-00	2
46	744553-0-00	1
47	304084-0-21	1
48	310795-0-00	20
49	310796-0-00	20
50	100891-0-10	20
51	304085-4-21	1

SEGUE  
FOLLOWS

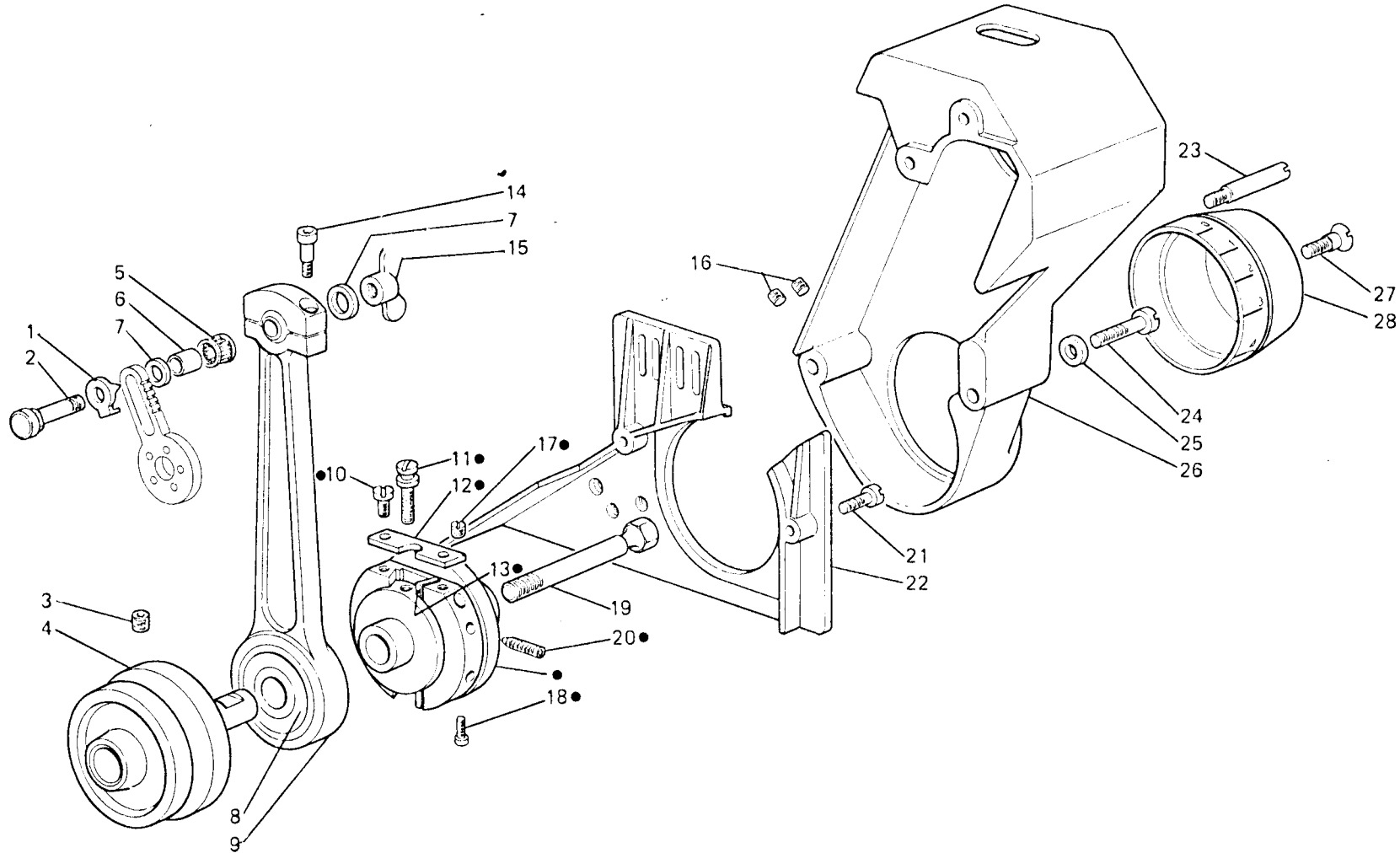


Fig. N.	Part. N. Piece N.	Qt.
	304449-4-20	1
1	304073-0-11	1
2	304086-0-10	1
3	729434-2-00	2
4	211891-2-00	1
5	201358-0-10	1
6	304436-0-10	1
7	704216-2-00	2
8	304480-0-00	1
9	207080-2-12	1
10	741721-2-00	2
11	304412-0-10	1
12	304413-0-10	1
13	304451-0-10	1
14	722119-2-00	2
15	200413-2-10	1
16	729012-2-00	2
17	745317-0-00	2
18	304462-0-20	2
19	207097-0-02	1
20	730061-2-00	2
21	722063-2-00	1
22	209902-0-00	1
23	207093-0-00	1
24	721516-2-00	1
25	704314-2-00	1
26	211892-2-00	1
27	202492-0-10	1
28	209134-0-00	1

SEGUE  
FOLLOWS

3

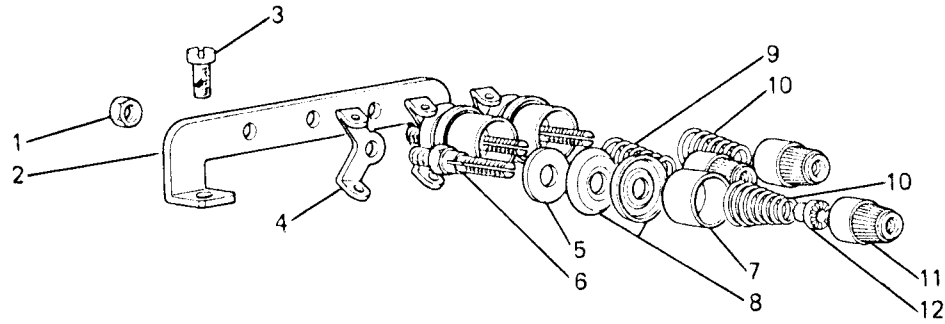


Fig. N.	Part. N. Piece N.	Qt.
1	746406-2-00	3
2	211897-0-00	1
3	741936-2-00	2
4	308503-0-01	3
5	206754-0-00	3
6	202225-0-11	3
7	202556-0-01	3
8	300218-0-10	6
9	202681-0-10	1
10	202227-0-10	2
11	202558-0-11	3
12	202229-0-11	3



GRUPPI DI COMPOSIZIONE - COMPOSITION KITS - GROUPES DE KIT - KIT GRUPPEN - GRUPOS DE COMPOSICION

ATTREZZATURE VARIE  
VARIOUS EQUIPMENT  
EQUIPEMENT DIVERS  
ANDERE BAUTEILE  
EQUIPOS VARIOS

**WFS-65**

1

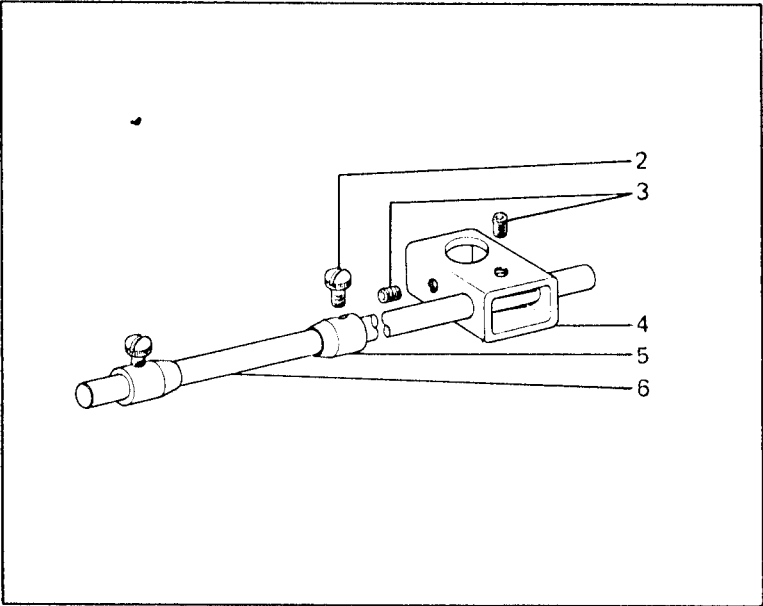


Fig. N.	Part. N. Piece N.	Qt.
1	991228-4-10	1
2	990596-0-10	2
3	729034-2-00	2
4	991263-2-00	1
5	990594-2-00	2
6	991229-0-00	1

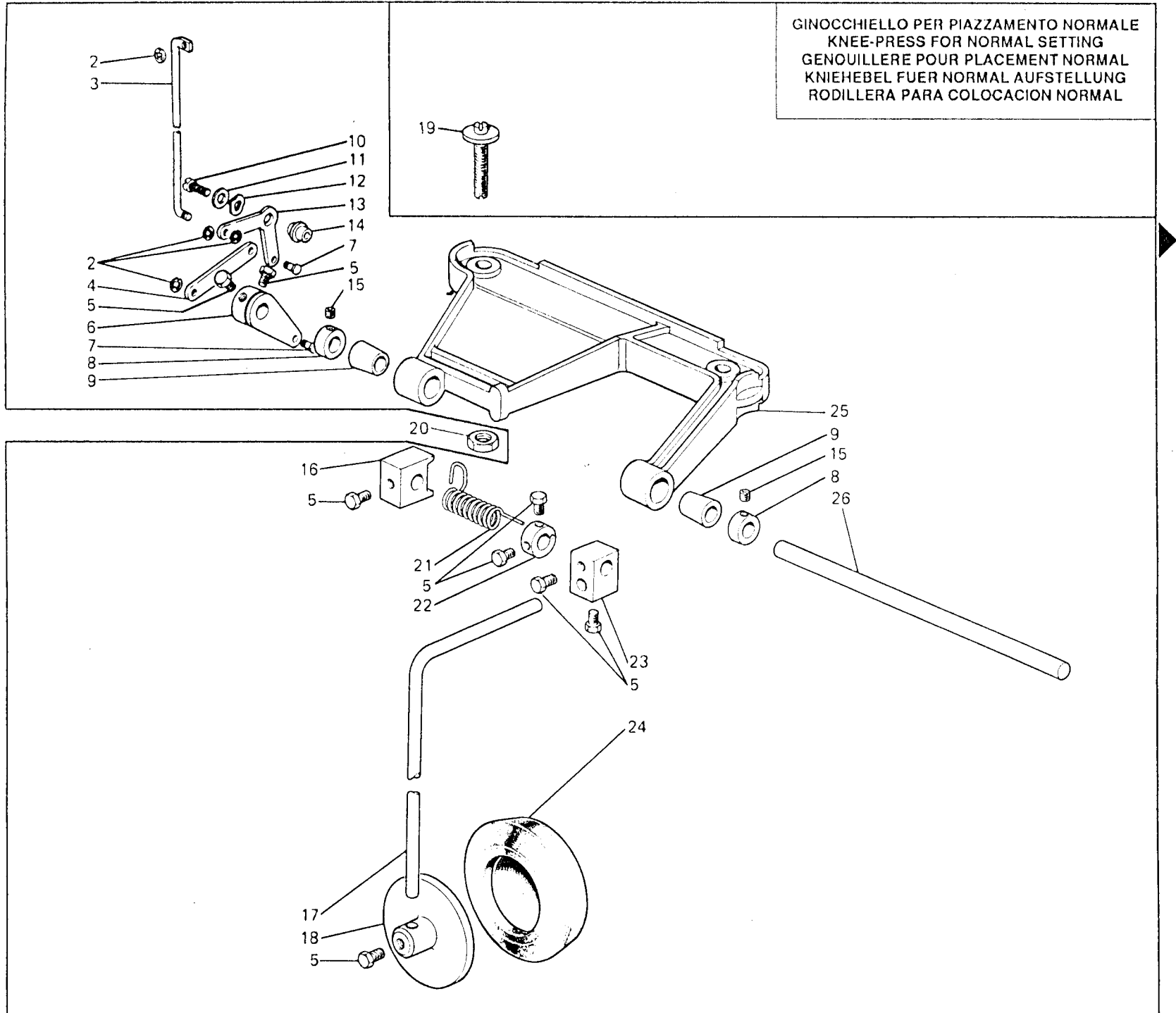
GRUPPI DI COMPOSIZIONE - COMPOSITION KITS - GROUPES DE KIT - KIT GRUPPEN - GRUPOS DE COMPOSICION

GRUPPO COMANDO  
CONTROL ASSEMBLY  
GROUPE COMMANDE  
WALZENSTEUERUNG  
GRUPO MANDO

**WFS-66**

WFS-66-001-00-0

GINOCCHIELLO PER PIAZZAMENTO NORMALE  
 KNEE-PRESS FOR NORMAL SETTING  
 GENOILLERE POUR PLACEMENT NORMAL  
 KNEIEBEL FUER NORMAL AUFSTELLUNG  
 RODILLERA PARA COLOCACION NORMAL

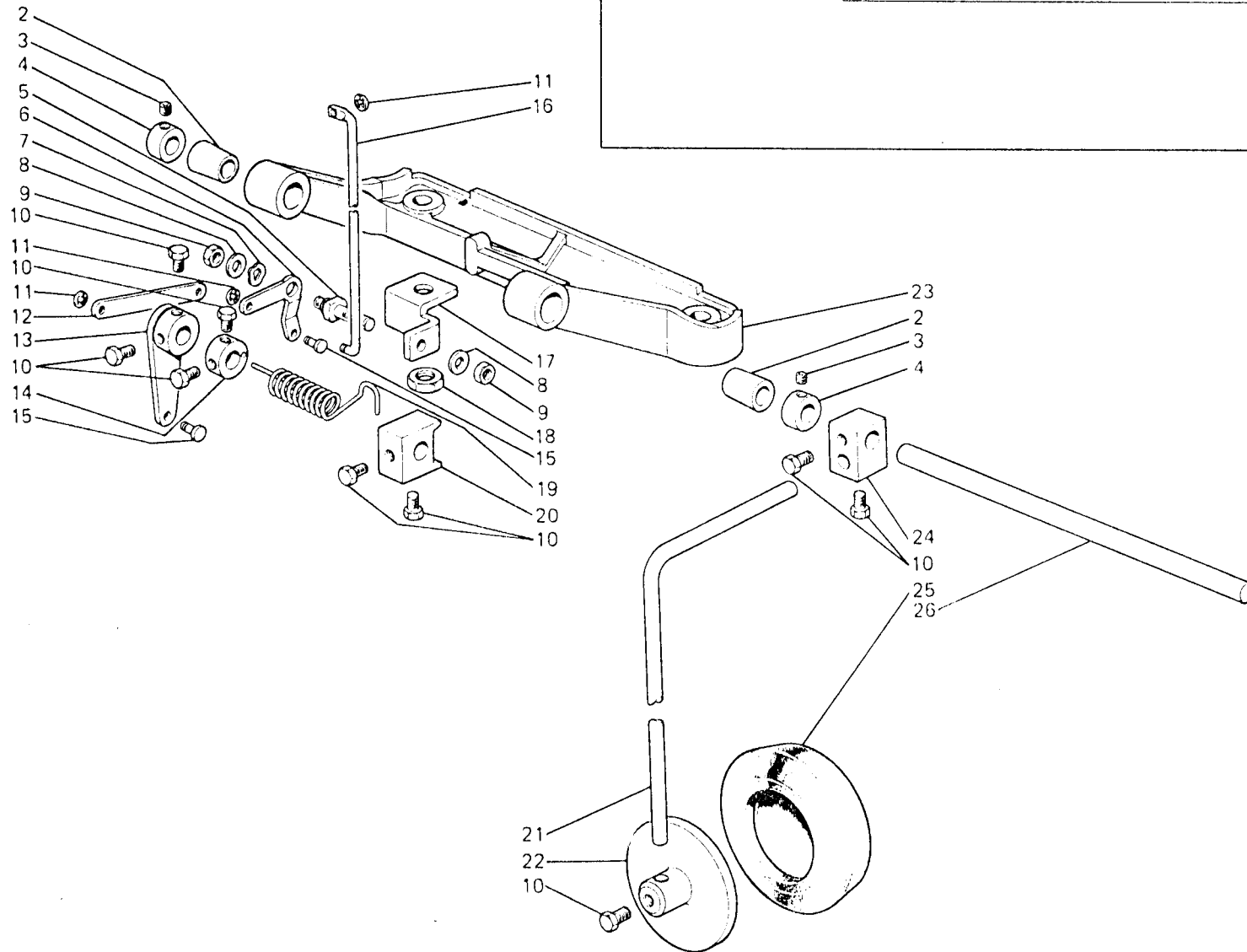


Rim<sup>30</sup>

Fig. N.	Part. N. Pieça N.	Qt.
1	920177-4-00	1
2	700206-0-00	4
3	920626-0-00	1
4	920625-0-00	1
5	740035-0-00	9
6	920623-2-00	1
7	920178-0-00	2
8	920242-2-00	2
9	920231-0-00	2
10	742068-2-00	1
11	704216-2-00	1
12	208220-0-00	1
13	920624-0-00	1
14	920621-0-00	1
15	729013-2-00	2
16	920128-0-00	1
17	920490-0-10	1
18	920105-0-10	1
19	901265-0-00	1
20	733008-2-00	2
21	920235-0-00	1
22	920114-0-10	1
23	920103-0-11	1
24	920113-0-11	1
25	920627-0-00	1
26	920230-0-00	1

WFS-66-002-00-0

GINOCCHIELLO PER PIAZZAMENTO INCASSATO  
 KNEE-PRESS FOR SUBMERGED SETTING  
 GENOILLERE POUR PLACEMENT ENCASTRE  
 KNIHEBEL FUER VERSENKT AUFSTELLUNG  
 RODILLERA PARA COLOCACION SUMERGIDA



Rim<sup>90</sup>

Fig. N.	Part. N. Piece N.	Qt.
1	920176-4-00	1
2	920231 0 00	2
3	729013-2-00	2
4	920242-2-00	2
5	920957-0-00	1
6	920956-0-00	1
7	208220-0-00	1
8	704216-2-00	2
9	733507-2-00	2
10	740035-0-00	9
11	700206-0-00	4
12	920179-0-00	1
13	920960-2-00	1
14	920114-0-10	1
15	920178-0-00	2
16	920961-0-00	1
17	920958-0-00	1
18	733008-2-00	1
19	920106-0-10	1
20	920128-0-00	1
21	920490-0-10	1
22	920105-0-10	1
23	920241-0-01	1
24	920103-0-11	1
25	920113-0-11	1
26	920230-0-00	1

GRUPPI DI COMPOSIZIONE - COMPOSITION KITS - GROUPES DE KIT - KIT GRUPPEN - GRUPOS DE COMPOSICION

CARTER  
COVER  
CARTER  
CARTER  
TAPADERAS

**WFS-68**

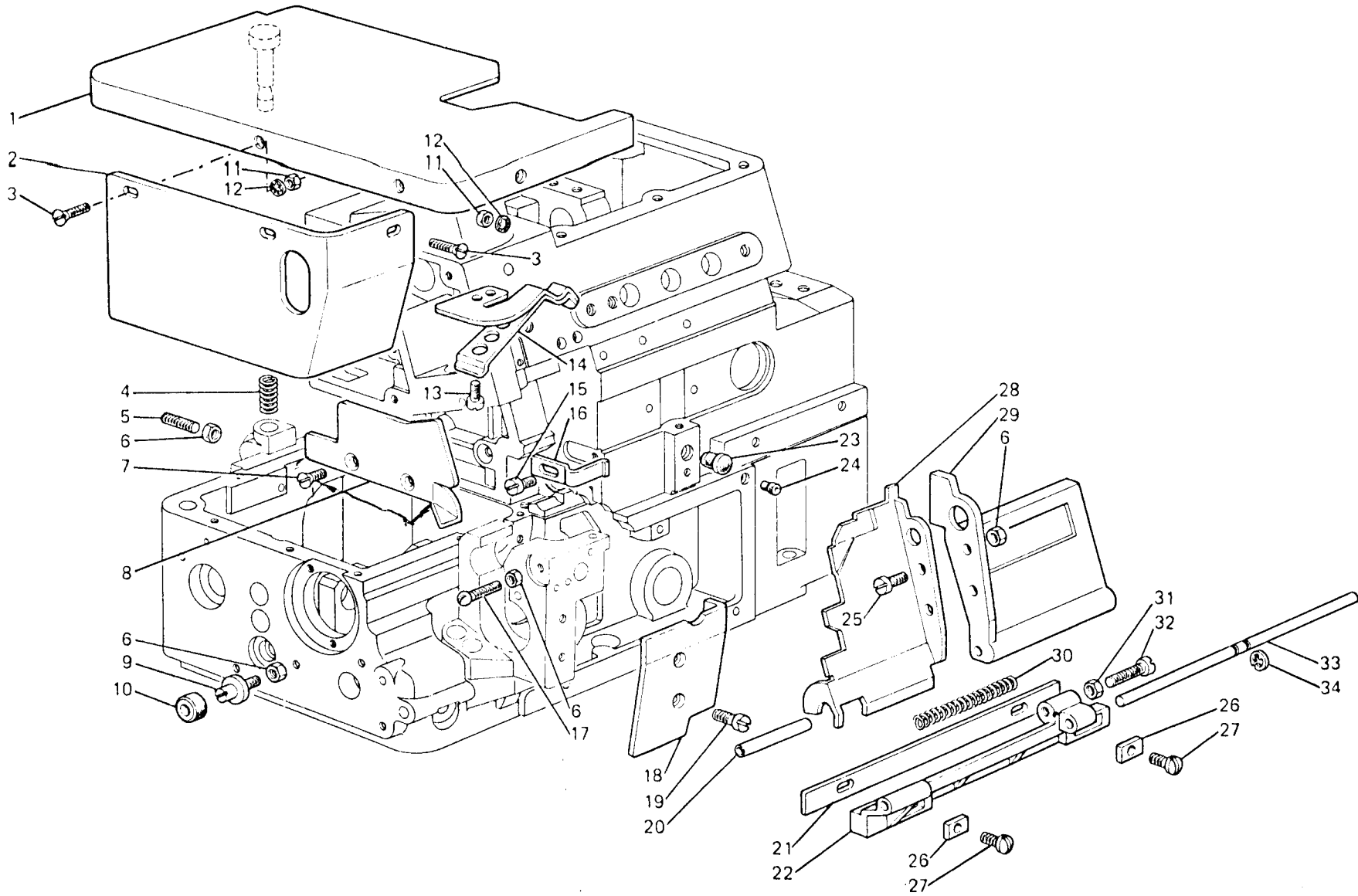


Fig. N.	Part. N. Piece N.	Qt.
1	211704-2-00	1
2	211689-0-00	1
3	744651-0-00	3
4	211410-0-00	1
5	211409-0-00	1
6	746007-2-00	5
7	744730-2-00	2
8	211714-0-00	1
9	211694-0-00	1
10	211028-0-00	1
11	746003-0-00	3
12	703203-0-00	3
13	721423-0-00	2
14	211703-2-00	1
15	721454-2-00	1
16	211686-0-00	1
17	211715-0-00	1
18	211691-0-00	1
19	741967-2-00	2
20	211682-0-00	1
21	211539-0-00	1
22	211582-0-00	1
23	202398-0-10	1
24	207856-0-00	1
25	200356-0-10	2
26	209720-0-00	2
27	722441-2-00	2
28	209684-0-00	1
29	211681-0-00	1
30	209683-0-00	1
31	733806-2-00	1
32	722143-2-00	1
33	211583-0-01	1
34	700207-0-00	1

GRUPPI DI COMPOSIZIONE - COMPOSITION KITS - GROUPES DE KIT - KIT GRUPPEN - GRUPOS DE COMPOSICION

KIT DI CAMPIONATURA  
SETTING KIT  
KIT DE ECHANTILLONAGE  
KIT PROBEENTNAHME  
KIT DE MUESTRARIO

**WFS-69**



1

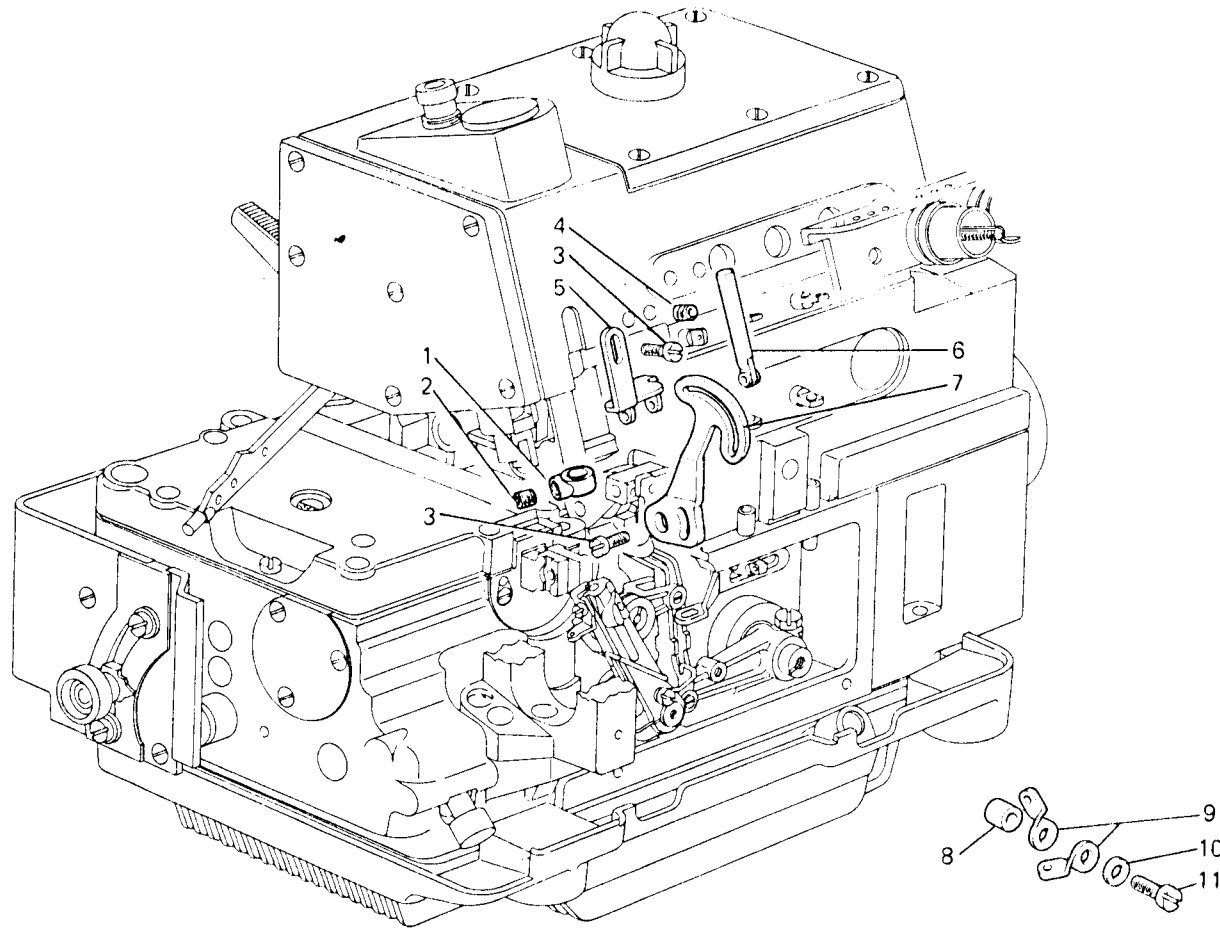
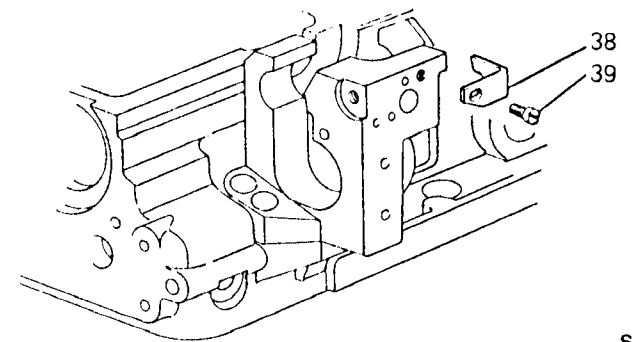
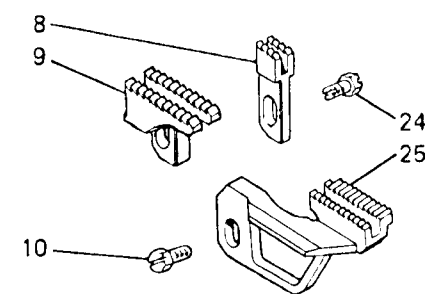
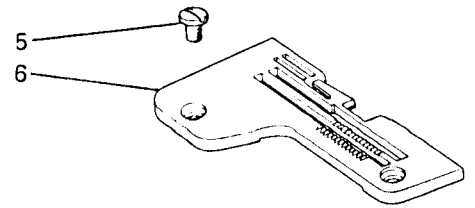
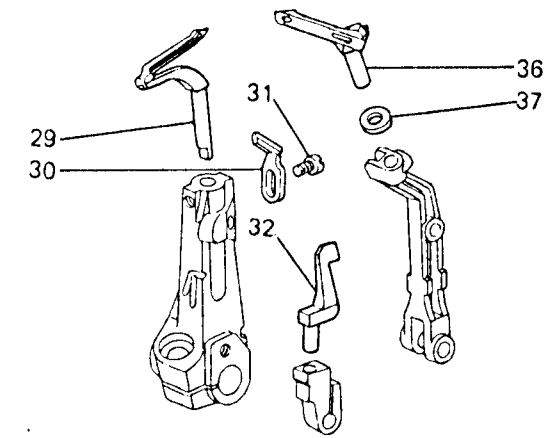
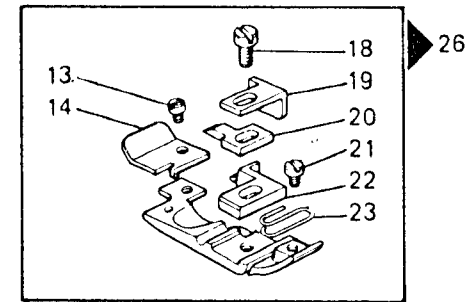
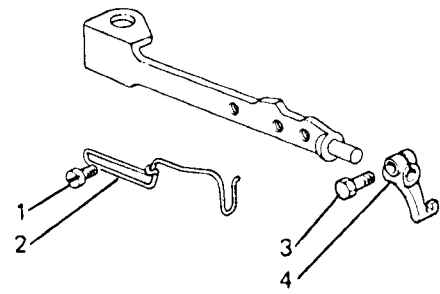
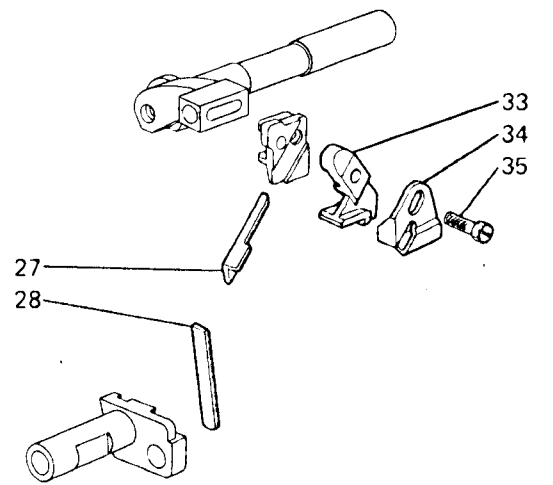
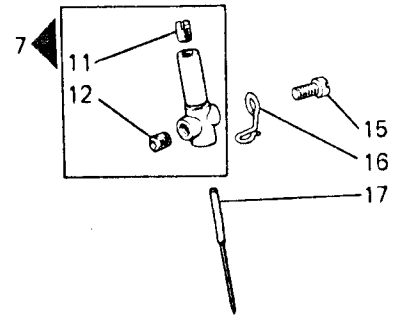


Fig. N.	Part. N. Piece N.	Qt.
1	211125-0-00	1
2	745812-2-00	1
3	741558-0-00	3
4	745810-2-00	1
5	211126-0-00	1
6	206714-2-00	1
7	211139-0-00	1
8	211742-0-00	1
9	211748-0-00	2
10	704104-2-00	1
11	722440-2-00	1

SEGUE  
FOLLOWS

Fig. N.	Part. N. Piece N.	Qt.
1	741433-2-00	2
2	991613-0-00	1
3	204947-0-10	1
4	206810-2-00	1
5	744742-2-00	2
6	203219-0-11	1
7	207520-2-00	1
8	202609-0-20	1
9	205952-0-01	1
10	202489-0-10	1
11	727021-5-00	1
12	745810-2-00	1
13	741413-2-00	1
14	203025-0-10	1
15	741415-2-00	1
16	207540-0-00	1
17	765200-6-90	---
18	741685-2-00	1
19	203768-0-12	1
20	203772-0-11	1
21	721412-2-00	1
22	206142-0-01	1
23	206143-0-00	1
24	202488-0-10	1
25	205951-0-00	1
26	206140-3-02	1
27	209348-0-00	2
28	202146-0-10	2
29	209264-0-01	1
30	209261-0-00	1
31	741538-2-00	2
32	207995-0-00	1
33	207653-0-01	1
34	211137-0-00	1
35	207421-0-01	1
36	211248-0-00	1
37	211305-0-00	1
38	203380-0-10	1
39	721443-2-00	1



SEGUE  
FOLLOWS

**CARATTERISTICHE E FUNZIONI DEI PARTICOLARI A RICHIESTA**  
**CHARACTERISTICS AND FUNCTIONS OF REQUESTED SPARE PARTS**  
**CARACTERISTIQUES ET FONCTIONS DES REFERENCES SUR DEMANDE**  
**KENNZEICHEN UND FUNKTIONEN DER TEILE AUF ANFRAGE**  
**CARACTERISTICAS Y FUNCIONES DE LOS REPUESTOS POR SOLICITUD**

Fig. N.	X	Y	DESCRIZIONE	DESCRIPTION	DESCRIPTION	BENENNUNG	DESCRIPCION
1		A	Coltello verticale.	Vertical knife.	Couteau vertical.	Vertikal-Messer.	Cuchilla vertical.
7			Per inserire elastico da 10 a 30 mm.	For inserting elastic from 10 to 30 mm.	Pour introduire élastique de 10 à 30 mm.	Zur Einführung eines Gummibandes von 10 bis 30 mm Breite.	Para inserir elástico de 10 a 30 mm.
14			Per non tagliare il tessuto.	For not cutting the fabric.	Pour ne pas couper le tissu.	Um den Stoff nicht zu schneiden.	Para no cortar el tejido.
15		W					
16			Salva ago fisso.	Fixed needle guard.	Protège aiguille fixe.	Fester Nadelschutz.	Salva aguja fijo.
18		W					
19		A					
20		A-D					

X = LARGHEZZA COSTA  
Y = PASSO/FINITURA  
A = ACCIAIO  
D = DENTATO  
G = GOMMATA  
W = WIDIA  
▲\*• = ABBINAMENTI OBBLIGATORI

WIDTH OF BIGHT  
DISTANCE/FINISHING  
STEEL  
TOOTHED  
RUBBERED  
WIDIA  
FIXED COUPLINGS

LARGEUR DE SURJET  
PAS/FINITION  
ACIER  
DENTE  
CAOUTCHOUTEE  
WIDIA  
JUMELAGES OBLIGES

UEBERWENDLICHBREITE  
TEILUNG/BEHANDLUNG  
STAHL  
GEZAEHNT  
GUMMIBELEGTEN  
WIDIA  
PFLICHT KOPPELUNGEN

ANCHO COSTURA  
PASO/ACABADO  
ACERO  
DENTADO  
ENGOMADO  
WIDIA  
COMBINACIONES OBLIGATORIAS

WFS-69-106-00-0

A RICHIESTA - ON REQUEST - SUR DEMANDE - AUF ANFRAGE - CON SOLICITUD

Rim®

3

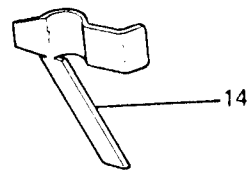
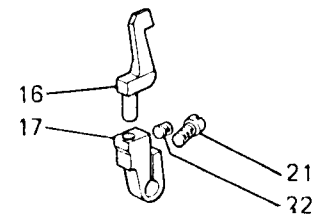
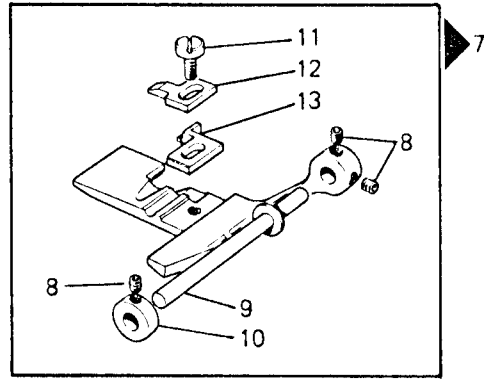
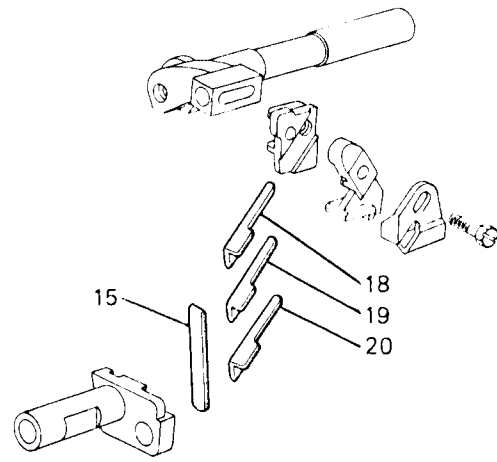
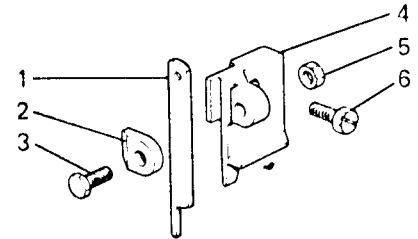


Fig. N.	Part. N. Piece N.	Qt.
1	202629-0-10	2
2	202620-0-10	1
3	202703-0-10	1
4	209590-0-00	1
5	733504-2-00	1
6	203525-0-11	1
7	207116-3-01	1
8	745800-2-00	3
9	207118-0-01	1
10	304458-0-10	1
11	741675-2-00	1
12	203772-0-11	1
13	202195-0-11	1
14	202300-0-10	1
15	207015-2-00	1
16	207992-0-01	1
17	207998-2-00	1
18	209347-0-00	1
19	209348-0-00	1
20	209350-0-00	2
21	741552-0-00	2
22	745812-2-00	1

SEGUE  
FOLLOWS

WFS-69-106-00-0

A RICHIESTA - ON REQUEST - SUR DEMANDE - AUF ANFRAGE - CON SOLICITUD

Rim®

4

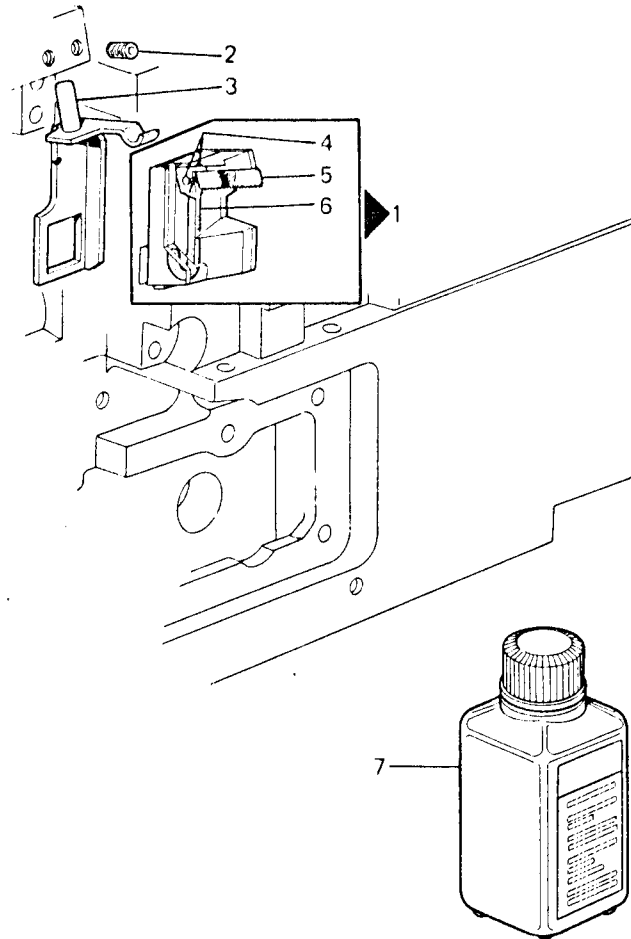


Fig. N.	Part. N. Piece N.	Qt.
1	209662-4-00	1
2	745800-2-00	1
3	210109-2-00	1
4	200490-0-00	2
5	209664-0-00	1
6	778419-0-00	1
7	990934-0-00	1