

647-00-2MF-20

1a EDIZIONE - EDITION 6/94 **n. 669**

GUIDA PER LA CONSULTAZIONE DEL CATALOGO RICAMBI	GUIDELINES FOR THE USE OF SPARE PARTS CATALOGUE	GUIDE A LA CONSULTATION DU CATALOGUE PIECES DE RECHAGE	ANLEITUNG FÜR DIE BENUTZUNG DES ERSATZTEILKATALOGES	GUIA PARA LA CONSULTA DEL CATALOGO DE REPUESTOS
<p>Tutti i particolari che compongono le teste sono riportati in più tavole come indicato nell'indice.</p>	<p>All the head component parts are shown in more tables as listed in the index.</p>	<p>Toutes les pièces qui composent les têtes ont été énoncées sur plusieurs tables comme indiqué en index.</p>	<p>Alle teile welche ein Oberteil bilden sind in mehreren Tafeln, wie im Inhaltsverzeichnis angegeben, abgebildet.</p>	<p>Todos los particulares que componen los cabezales son reflejados en más mesas como indicado en el índice.</p>
<p>I particolari che compongono un gruppo sono riquadrati; i sottogruppi, anch'essi riquadrati, sono inseriti nel gruppo di appartenenza.</p>	<p>The parts that are components of an assembly are represented within a square; the sub-assembly, also represented within a square, are included in the assembly they are part of.</p>	<p>Les pièces qui composent un groupe sont bordées; les sous-groupes eux mêmes bordés, sont insérés dans le groupe d'appartenance.</p>	<p>Alle Teile welche eine Teilegruppe bilden sind umrahmt; die Untergruppen, ebenfalls umrahmt, sind in der betreffenden Teilegruppe angeführt.</p>	<p>Los particulares que componen un grupo son encuadrados. Los subgrupos, aunque si son encuadrados, son inseridos en el grupo de pertenencia.</p>
<p>I particolari o i gruppi non comuni a tutte le teste riportate nel catalogo sono richiamati con una lettera; per la loro consultazione rimandiamo alle relative tabelle delle varianti pubblicate nella stessa tavola oppure nelle ultime pagine del catalogo.</p>	<p>A letter indicates parts or assemblies not common to all heads shown in the catalogue, in this case, refer to the relative charts of variables published in the same table or in the last pages of the catalogue.</p>	<p>Les composants ou les groupes non communs à toutes les têtes indiquées dans le catalogue sont rappelés par une lettre; pour leur consultation se référer aux relatives fiches des variantes publiées sur la table même ou dans les dernières pages du catalogue.</p>	<p>Alle Teile oder Teilegruppen, welche nicht in allen im Ersatzteilkatalog angeführten Oberteilen gemein sind, sind mit einem Buchstaben gekennzeichnet; für deren zu Rateziehung verweisen wir auf die auf derselben Tafel angeführten Tabellen der Varianten oder auf die letzten Seiten des Kataloges.</p>	<p>Los particulares o los grupos no comunes a todos los cabezales reproducidos en el catálogo, son señalados con una letra. Para su consulta ver las relativas tablas de las variantes publicadas en la misma mesa o bien en las últimas páginas del catalogo.</p>
<p>Gli organi di cucitura, le guide e gli accessori sono preceduti da tavole riepilogative con l'indicazione dei particolari in dotazione e di quelli a richiesta.</p>	<p>The sewing parts, guides, folder and accessories are preceded by summary tables indicating standard parts and parts supplied on request.</p>	<p>Les éléments de couture, les guides et les accessoires sont précédés de tables de récapitulation avec l'index des composants en dotation et ceux sur demande.</p>	<p>Vor den Tafeln mit den Nähwerkzeugen, Führungen und Ausstattungen befinden sich zusammenfassende Tafeln mit Angabe der in Normalausstattung und der auf Anfrage lieferbaren Teile.</p>	<p>Los organos de costura, las guías y accesorios son precedidos de un resumen de mesas con la indicación de los particulares dotados y los solicitados.</p>
<p>Per ordini di aghi, precisare il simbolo riportato in catalogo; in caso di dubbio allegare un ago campione o una bustina vuota.</p>	<p>When ordering needles, please specify catalogue symbol; if you have doubts, send a sample needle or an empty needle bag with your order.</p>	<p>Pour les commandes d'aiguilles, préciser le symbole indiqué sur le catalogue, en cas de doute joindre une aiguille échantillon ou un sachet vide.</p>	<p>Für Aufträge über Nähadeln ist die im Ersatzteilkatalog angeführte Teilenummer anzugeben; in Zweifelsfällen ist eine Nadel als Muster oder ein entsprechender leerer Nadelbrief beizulegen.</p>	<p>Por pedido de agujas, precisar el símbolo reproducido en el catálogo. En caso de duda, adjuntar un modelo o un sobre vacío.</p>

# Rim<sup>3</sup> TAV. 1

CARTER E PIANO DI LAVORO - CARTERS AND WORKING PLATE - CARTERS ET PLAN DE TRAVAIL - SCHUTZDECKEL U. ARBEITSPLATTE - CARTER Y PUESTO DE TRABAJO

Fig. N.	Part. N. Piece N.	Qt.
1	741956-2-00	4
2	209412-0-00	1
3	209413-0-00	1
4	209690-0-00	1
5	725032-0-00	4
6	703405-0-00	4
7	210145-0-00	1
8	741387-2-00	7
9	209724-0-00	1
10	741967-2-00	6
11	209415-0-00	1
12	209416-0-00	1
13	209389-0-00	1
14	209714-0-00	1
15	744730-2-00	2
16	209710-0-01	1
17	733806-2-00	3
18	209723-0-00	1
19	209688-0-00	1
20	209417-0-00	1
21	745812-2-00	1
22	209719-0-00	1
23	721454-2-00	1
24	209686-0-00	1
25	207980-0-00	1
26	202398-0-10	1
27	209684-0-00	1
28	200356-0-10	2
29	211582-0-00	1
30	209720-0-00	2
31	722441-2-00	2
32	209683-0-00	1
33	722143-2-00	1
34	211583-0-00	1
35	722063-2-00	2
36	209020-0-00	1
37	209681-0-00	1
38	211055-0-00	1
39	700207-0-00	1

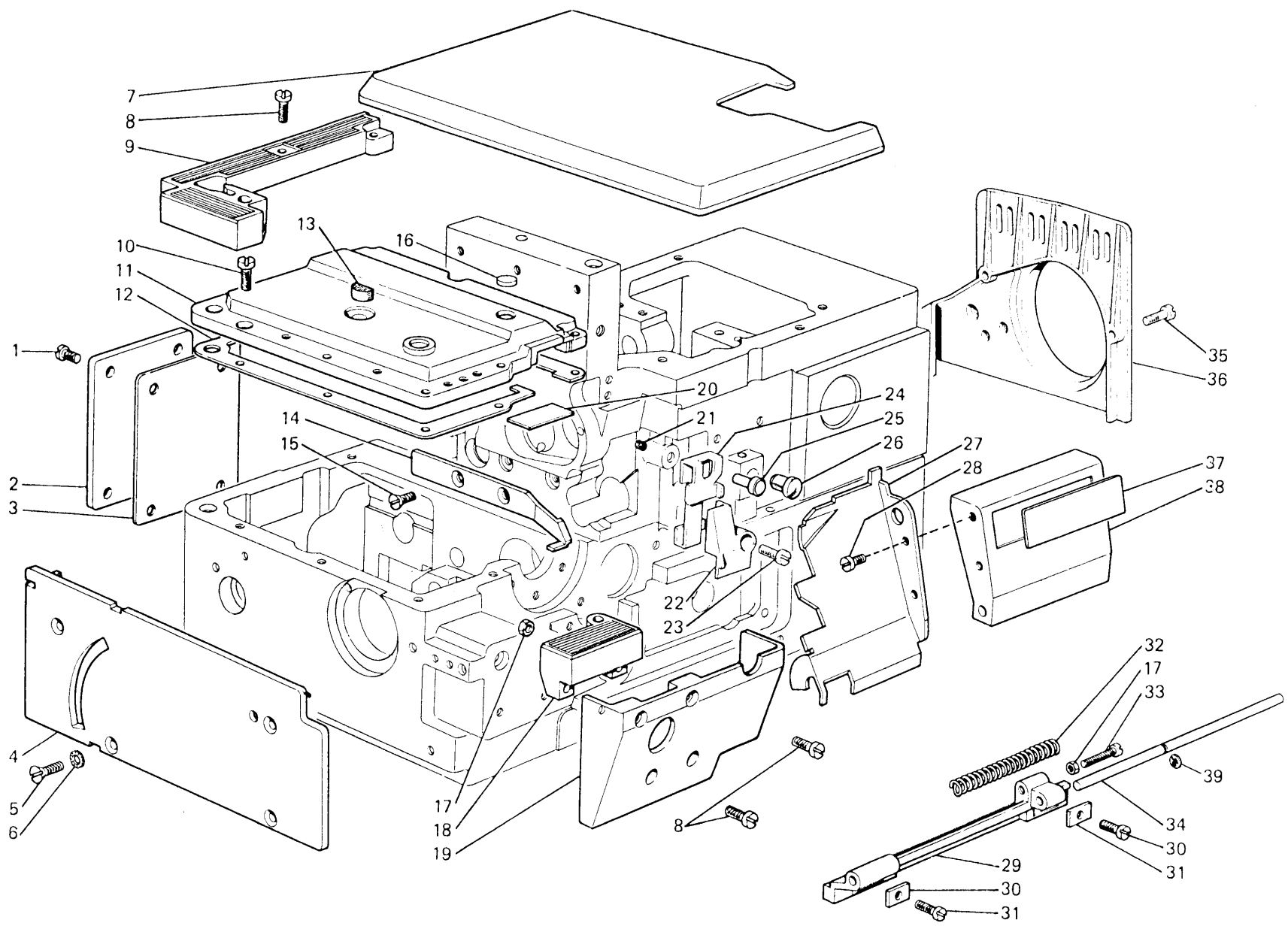
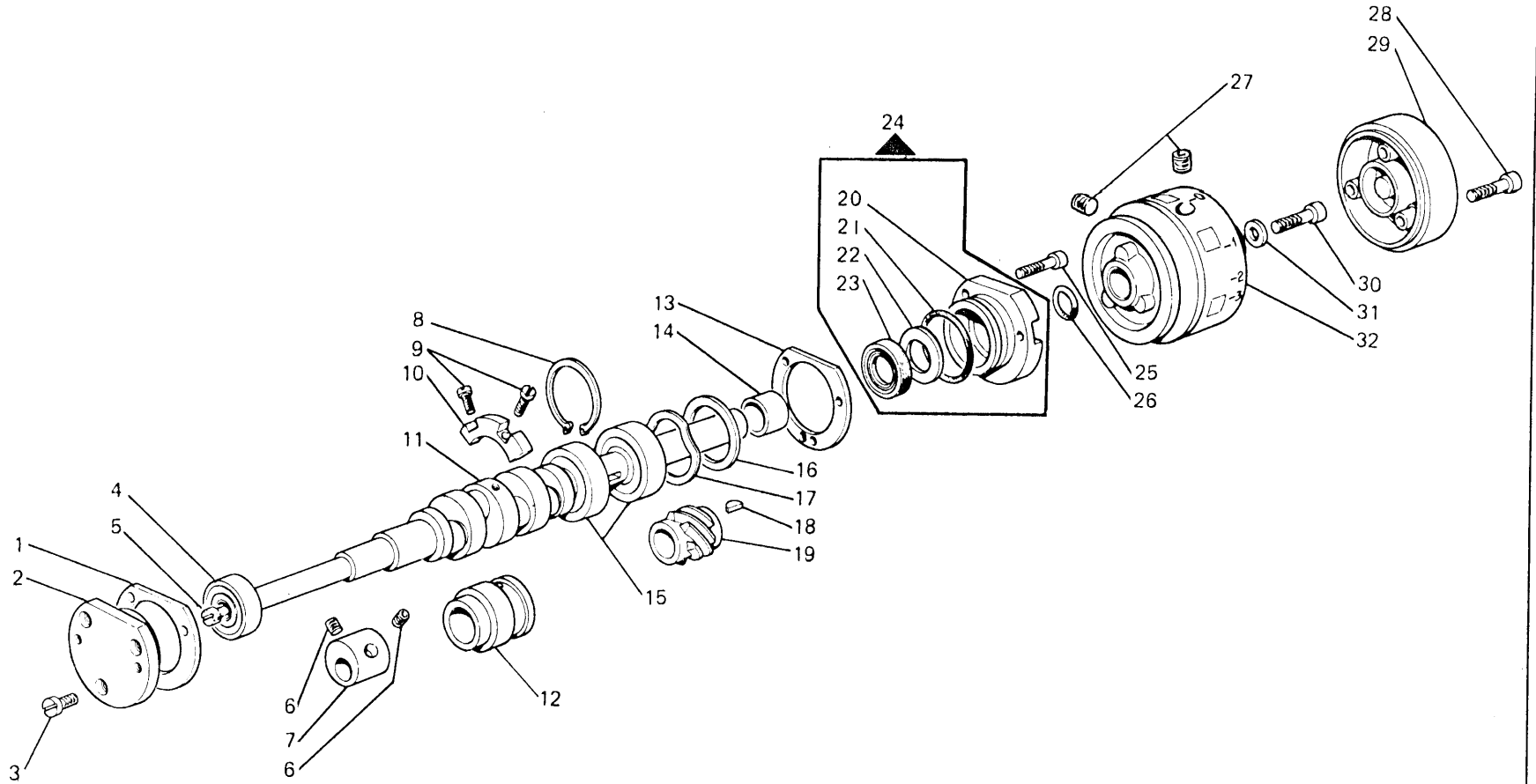



Fig. N.	Part. N. Pieça N.	Qt.
1	206543-0-01	1
2	206680-0-01	1
3	741956-2-00	3
4	202389-0-10	1
5	209610-0-01	1
6	745815-2-00	2
7	209144-2-00	1
8	202386-0-10	1
9	721473-2-00	2
10	209146-0-00	1
11	211102-2-00	1
12	209104-0-00	1
13	209111-0-00	1
14	206692-0-00	1
15	202387-0-10	2
16	209185-0-00	1
17	206689-0-01	1
18	204122-0-10	1
19	206556-0-01	1
20	209109-0-00	1
21	701133-0-00	1
22	206693-0-00	1
23	700630-0-00	1
24	209110-4-00	1
25	722063-2-00	3
26	701116-0-00	1
27	729034-2-00	2
28	722461-2-00	3
29	211131-0-00	1
30	742675-0-00	1
31	704236-2-00	1
32	209125-0-00	1



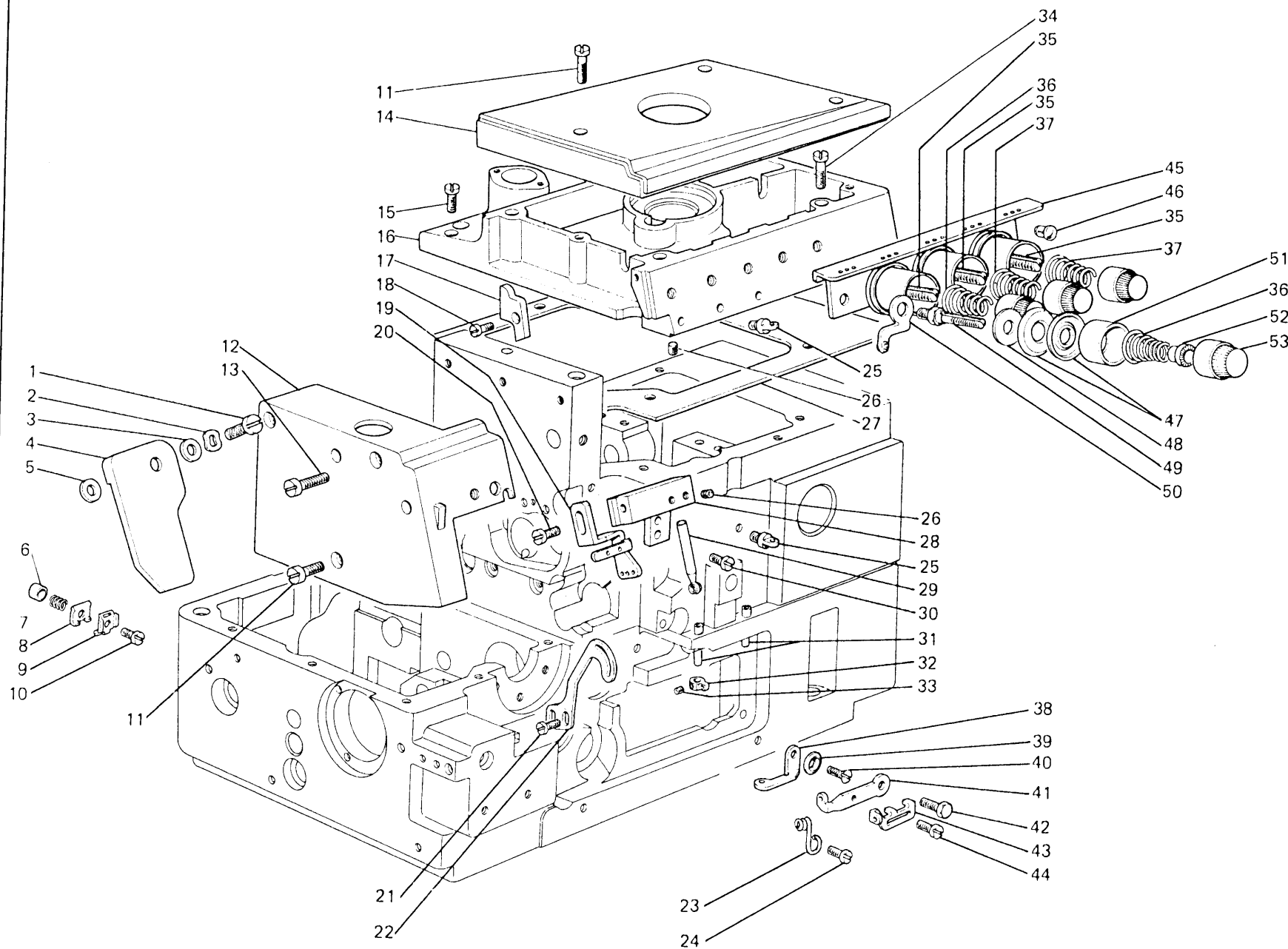
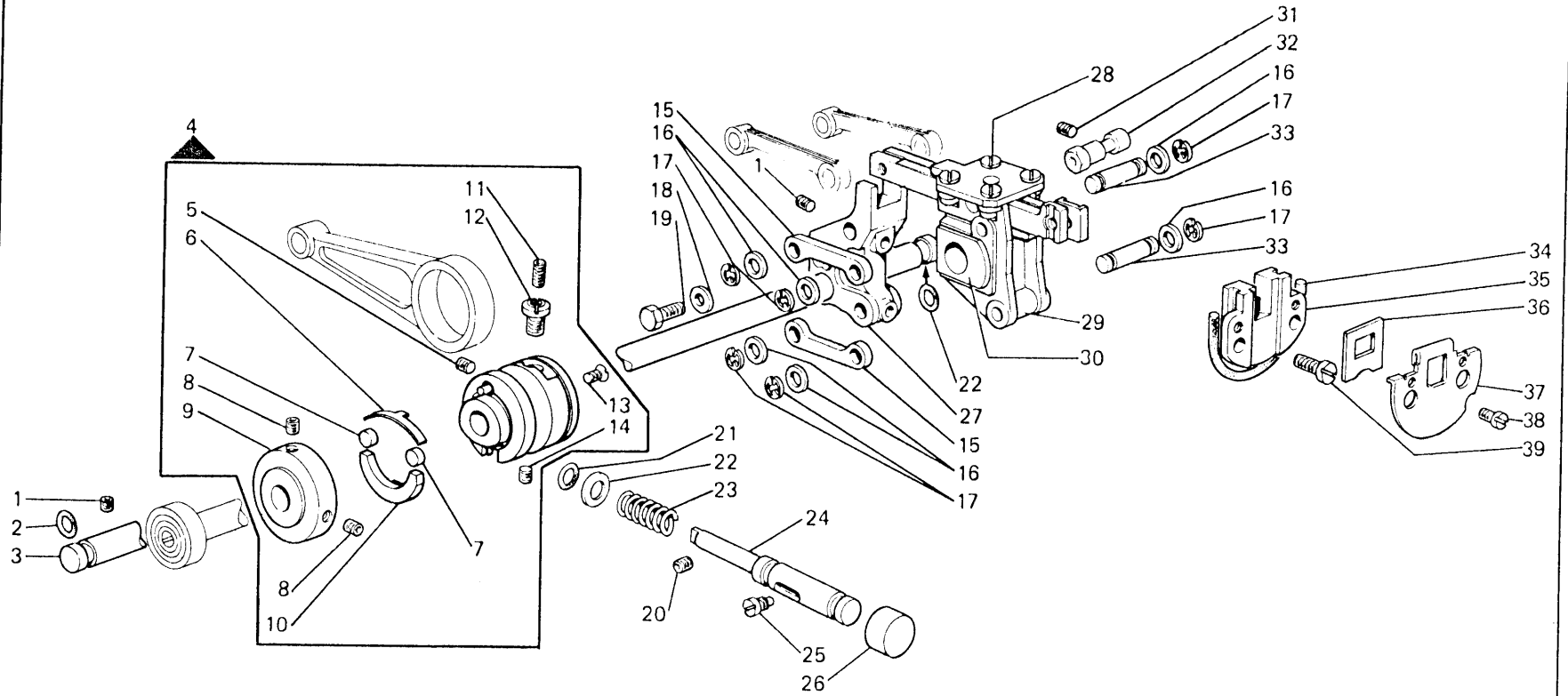

Fig. N.	Part. N. Pice N.	Qt.
1	743547-2-00	1
2	208220-0-00	1
3	704630-0-00	1
4	209022-0-00	1
5	704717-0-00	1
6	209068-0-00	1
7	209173-0-00	1
8	209171-0-00	1
9	209170-0-00	1
10	741634-2-00	1
11	741967-2-00	4
12	210063-0-00	1
13	722153-2-00	2
14	209053-0-00	1
15	721474-2-00	2
16	210015-2-00	1
18	210105-0-00	1
19	722042-0-00	1
19	209778-0-00	1
20	722400-2-00	1
21	741558-0-00	2
22	207895-0-02	1
23	300827-0-20	1
24	741657-0-00	1
25	209760-0-00	5
26	745800-2-00	4
27	210014-0-00	1
28	209767-0-00	1
29	206714-2-00	1
30	741936-2-00	2
31	206740-0-00	2
32	203135-2-10	1
33	745002-0-00	1
34	721086-2-00	4
35	206747-0-02	3
36	202227-0-10	2
37	202681-0-10	2
38	209775-0-00	1
39	209243-0-00	1
40	724472-2-00	1
41	209771-0-00	1
42	720431-2-00	1
43	209772-0-00	1
44	721412-2-00	1
45	209753-0-00	1
46	207893-0-00	3
47	300218-0-10	8
48	206754-0-00	4
49	208169-0-01	1
50	206713-2-00	1
51	202556-0-01	4
52	202229-0-11	4
53	202558-0-00	4

# Rim<sup>®</sup> TAV. 5

COMANDO GRIFFE - FEED DOGS CONTROL - COMMANDE GRIFFES - TRANSPORTEURANTRIEB - MANDO DIENTES

Fig. N.	Part. N. / Piece N.	Qt.
1	729012-2-00	2
2	701006-0-00	1
3	209380-0-00	1
4	209448-4-11	1
5	745815-2-00	1
6	209471-0-00	1
7	209442-0-00	2
8	745812-2-00	2
9	209445-2-02	1
10	209443-0-10	1
11	729031-2-00	1
12	211444-0-00	1
13	724430-2-00	4
14	728232-0-00	1
15	209376-0-00	4
16	703802-0-00	8
17	700005-0-00	8
18	704409-2-00	1
19	740087-2-00	1
20	729032-2-00	1
21	701004-0-00	1
22	704314-2-00	1
23	202408-0-10	1
24	209393-0-01	1
25	350555-0-00	1
26	209449-0-00	1
27	209378-0-00	1
28	741936-2-00	4
29	211427-3-00	1
30	211375-0-00	1
31	729033-2-00	1
32	209379-0-00	1
33	321055-0-00	4
34	207948-0-00	1
35	211381-0-00	1
36	209384-0-00	1
37	209386-2-00	1
38	741611-2-00	2
39	722063-2-00	2



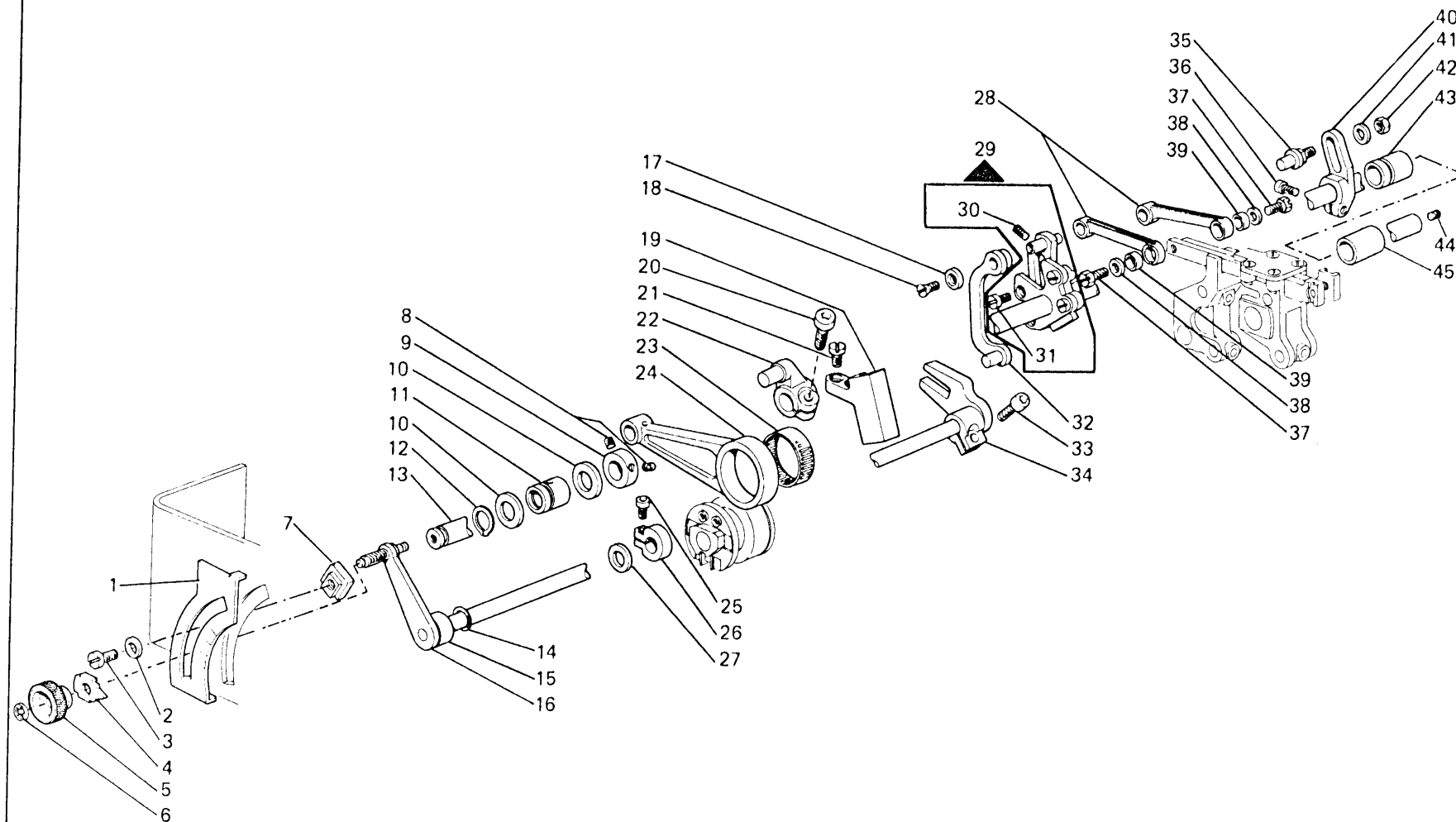
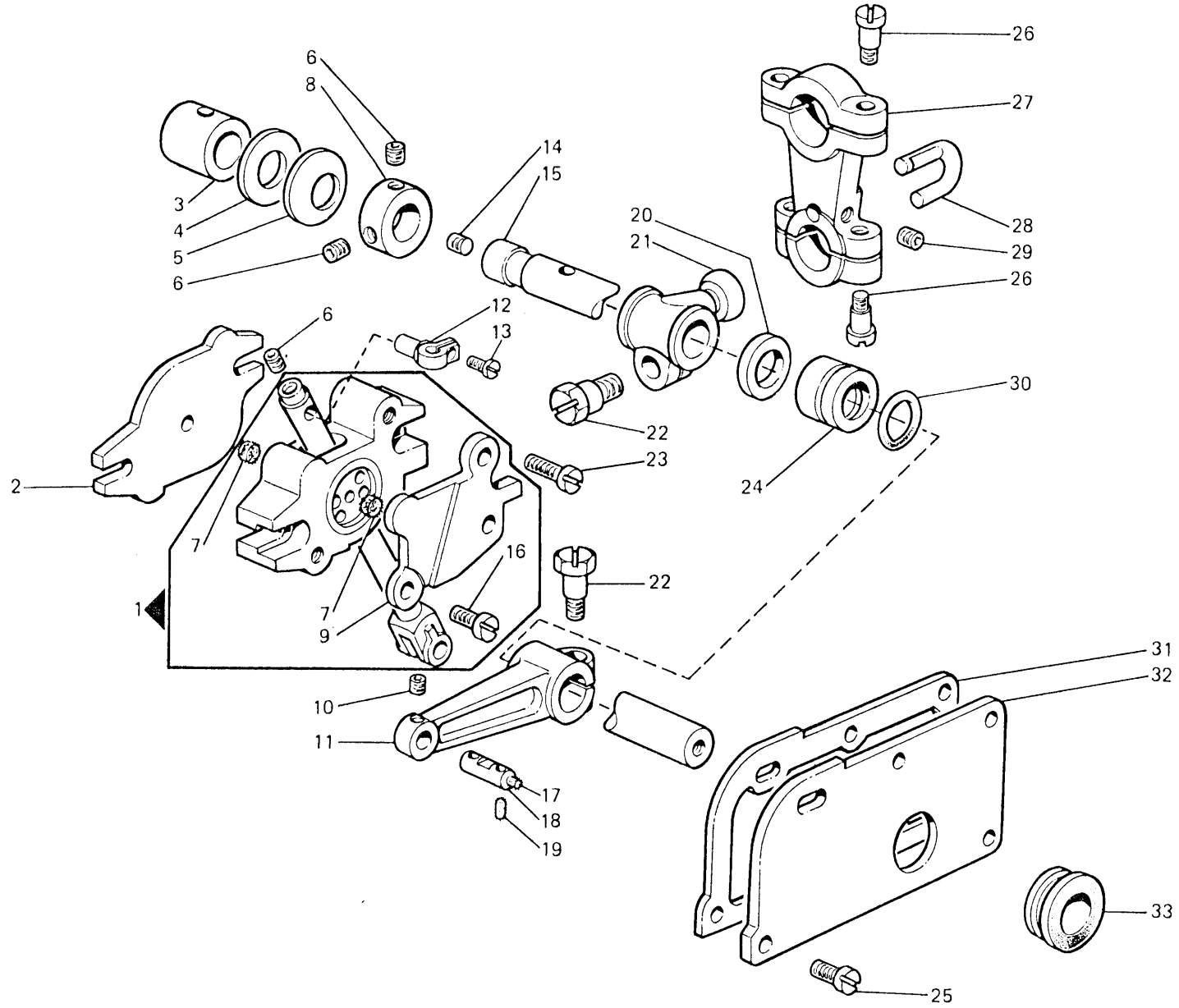

Fig. N.	Part. N. / Piece N.	Qt.
1	209693-0-00	1
2	704409-2-00	2
3	721475-2-00	2
4	206796-0-00	1
5	206798-0-00	1
6	700207-0-00	1
7	211612-0-01	2
8	729013-2-00	2
9	313060-2-10	1
10	704853-0-00	2
11	211406-0-00	1
12	700012-0-00	1
13	211046-2-00	1
14	701007-0-00	1
15	209411-0-00	1
16	209408-2-00	1
17	207719-0-00	1
18	724032-0-00	1
19	209402-0-00	1
20	744334-2-00	1
21	741967-2-00	2
22	211382-2-00	1
23	202384-0-10	1
24	209390-0-00	1
25	741745-2-00	1
26	100620-2-10	1
27	704829-0-00	1
28	209400-0-00	2
29	211394-3-01	1
30	745827-2-00	2
31	741936-2-00	4
32	209401-2-01	1
33	722422-2-00	1
34	209403-2-00	1
35	209388-0-01	1
36	744332-2-00	1
37	202490-0-10	2
38	705208-0-00	2
39	202032-0-11	2
40	211387-2-00	1
41	704306-2-00	1
42	733806-2-00	1
43	211407-0-00	1
44	727036-2-00	1
45	211049-0-00	1



Fig. N.	Part. N. Plece N.	Qt.
1	209797-3-00	1
2	209236-0-02	1
3	211209-0-01	1
4	705036-0-00	1
5	211281-0-00	1
6	729013-2-00	3
7	209609-0-00	2
8	313060-2-10	1
9	209215-0-00	1
10	745810-2-00	1
11	211204-2-00	1
12	209222-2-01	1
13	741535-0-00	1
14	727036-2-00	1
15	211203-2-01	1
16	741956-0-00	2
17	778403-0-00	1
18	209206-0-00	1
19	778202-0-00	2
20	704884-0-00	1
21	211217-2-00	1
22	201128-0-10	2
23	721515-2-00	2
24	211210-0-01	1
25	741936-2-00	4
26	722089-2-00	4
27	209270-2-02	1
28	209272-0-00	1
29	745812-2-00	1
30	701015-0-00	1
31	209225-0-02	1
32	211227-0-00	1
33	211226-0-00	1



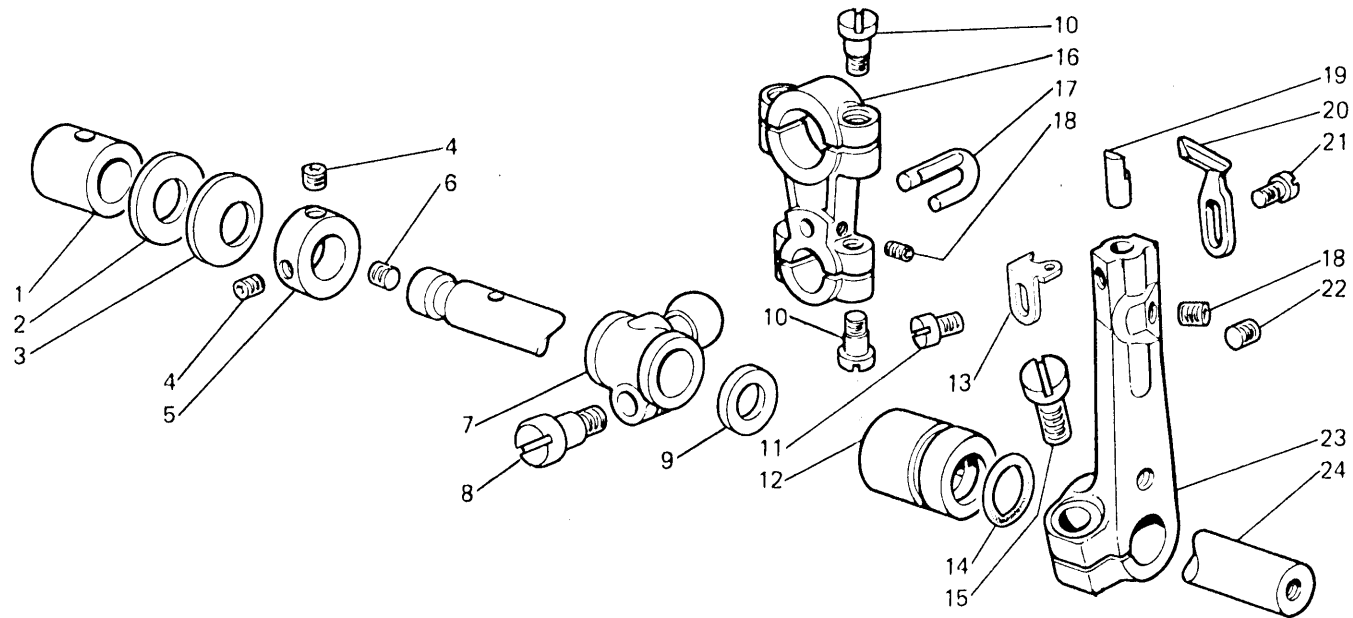
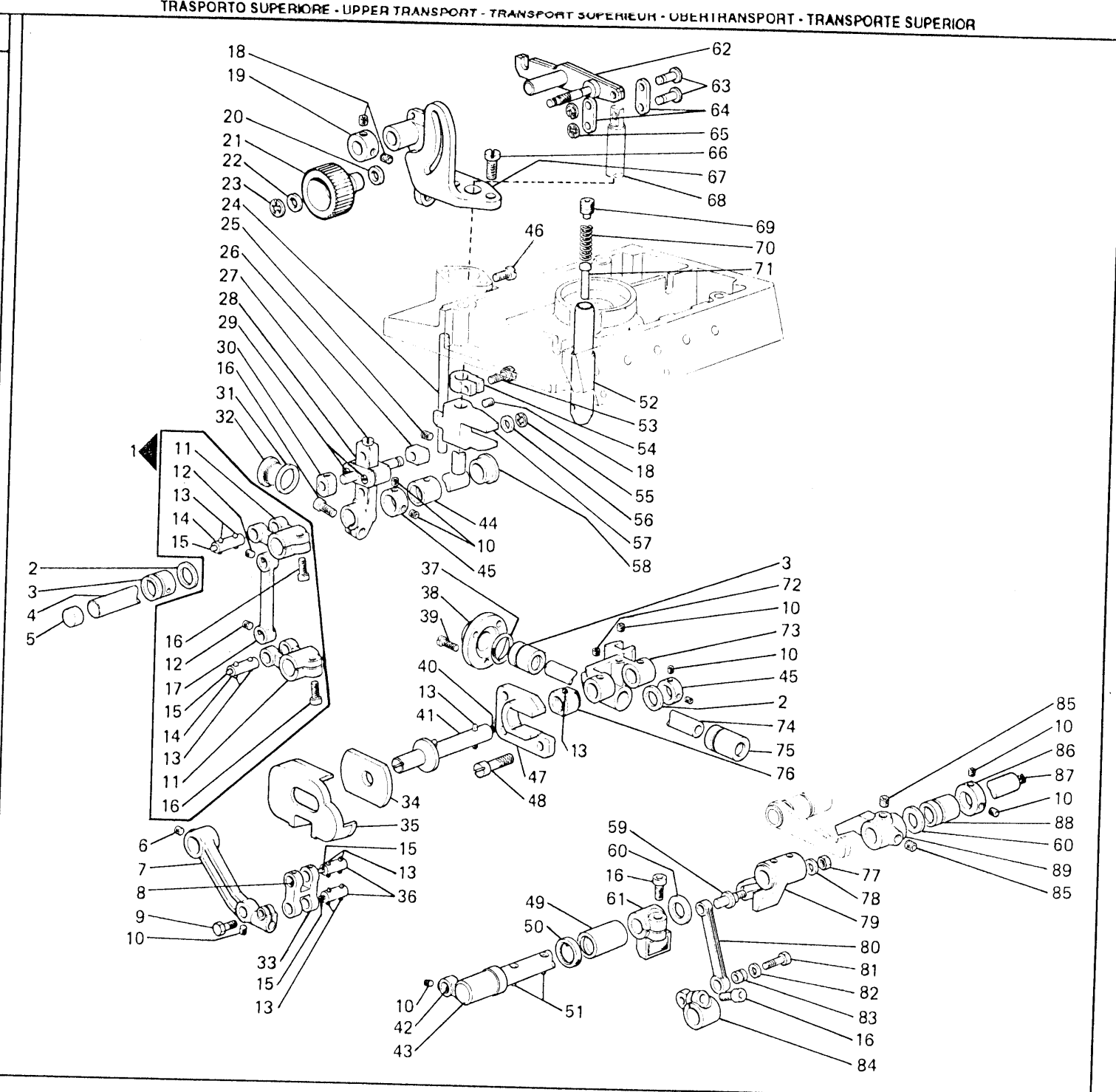

Fig. N.	Part. N. Piece N.	Qt.
1	211209-0-01	1
2	705036-0-00	1
3	211281-0-00	1
4	729013-2-00	2
5	313060-2-10	1
6	727036-2-00	1
7	211221-2-00	1
8	201128-0-10	1
9	704883-0-00	1
10	722089-2-00	4
11	741415-2-00	1
12	211252-0-01	1
13	209774-0-00	1
14	701015-0-00	1
15	721883-0-00	1
16	209270-2-02	1
17	209272-0-00	1
18	745812-2-00	2
19	209258-0-00	1
20	209261-0-01	1
21	741538-2-00	2
22	745800-2-00	1
23	209250-2-00	1
24	211277-2-00	1

Fig. N.	Part. N. Piece N.	Qt.	Fig. N.	Part. N. Piece N.	Qt.
1	211029-4-00	1	54	308326-2-01	1
2	704841-0-00	2	55	700207-0-00	1
3	209200-0-00	2	56	704813-0-00	1
4	210047-0-00	1	57	210030-2-00	1
5	211056-0-00	1	58	210168-0-00	1
6	729013-2-00	1	59	209388-0-01	1
7	210037-2-00	1	60	704863-0-00	2
8	778511-0-00	1	61	210081-2-00	1
9	204947-0-10	1	62	210033-0-10	1
10	745812-2-00	8	63	990311-0-10	2
11	211027-2-00	2	64	210122-0-00	2
12	745811-2-00	2	65	700205-0-00	2
13	778202-0-00	10	66	721494-2-00	2
14	300209-0-10	2	67	210125-0-00	1
15	778208-0-00	4	68	210120-0-00	1
16	744334-2-00	5	69	310569-0-00	1
17	210028-0-00	1	70	205021-0-10	1
18	729012-2-00	3	71	210072-0-00	1
19	302284-2-10	1	72	730022-2-00	1
20	704308-2-00	1	73	210020-2-00	1
21	210138-0-00	1	74	210052-0-00	1
22	704106-2-00	1	75	209201-0-00	1
23	700206-0-00	1	76	210077-0-00	1
24	209697-0-00	1	77	733806-2-00	1
25	729033-2-00	1	78	704802-0-00	1
26	210035-0-00	1	79	210082-0-00	1
27	741634-2-00	1	80	209400-0-00	1
28	210034-3-00	1	81	202490-0-10	1
29	210150-0-00	2	82	705208-0-00	1
30	210092-0-01	1	83	202032-0-11	1
31	705892-0-00	1	84	210024-2-00	1
32	202026-0-10	1	85	745827-2-00	2
33	210079-0-00	1	86	209584-0-00	1
34	210167-0-00	1	87	778439-0-00	1
35	210163-0-00	1	88	209583-0-01	1
36	210078-0-00	2	89	210083-2-00	1
37	701022-0-00	1			
38	210071-0-00	1			
39	741685-2-00	3			
40	778564-0-00	1			
41	210054-0-00	1			
42	211439-0-00	1			
43	210080-2-00	1			
44	210048-0-00	1			
45	206606-0-00	2			
46	721515-2-00	1			
47	210076-0-00	1			
48	722063-2-00	3			
49	209119-0-00	1			
50	927912-0-00	1			
51	778445-0-00	2			
52	210026-0-00	1			
53	305194-0-00	1			



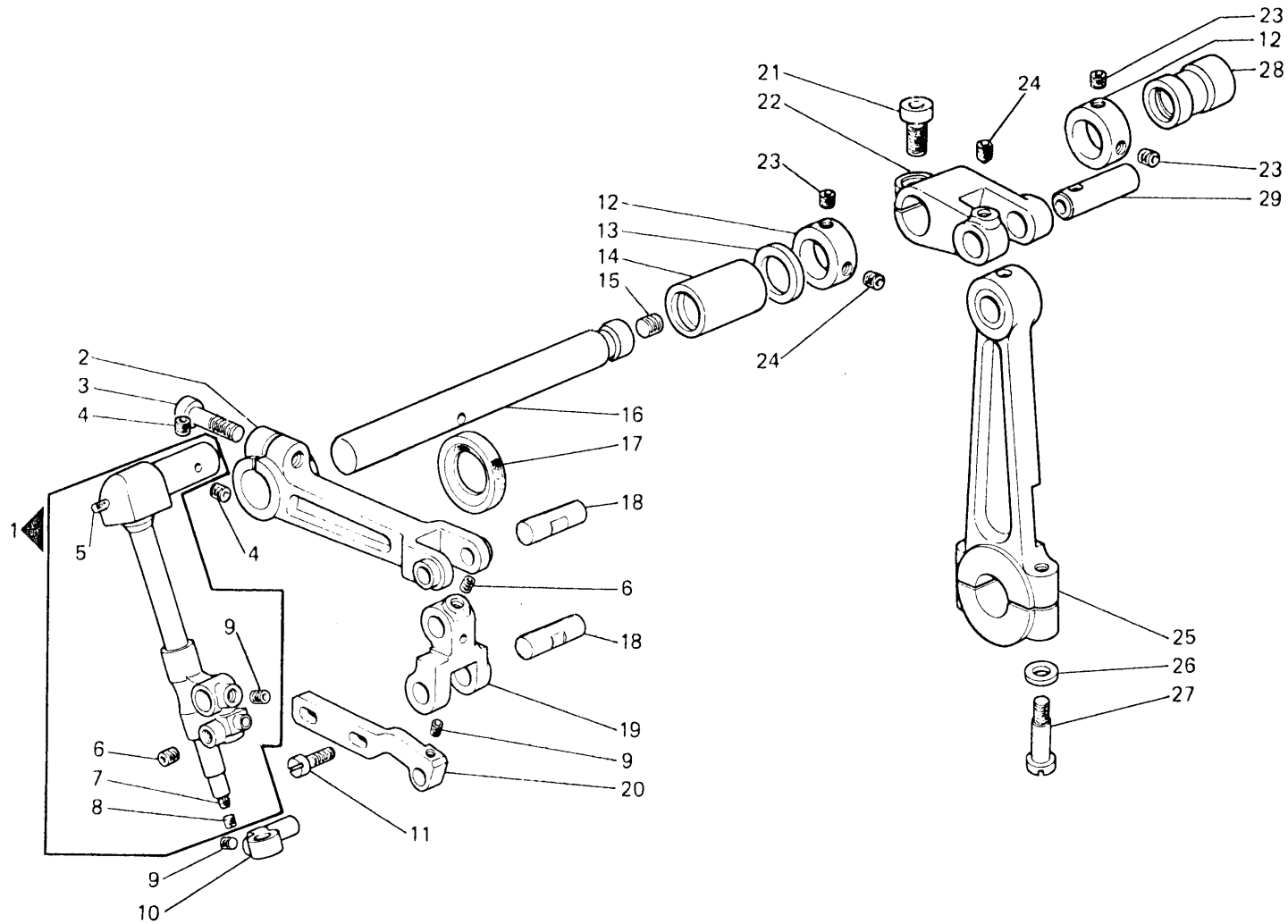
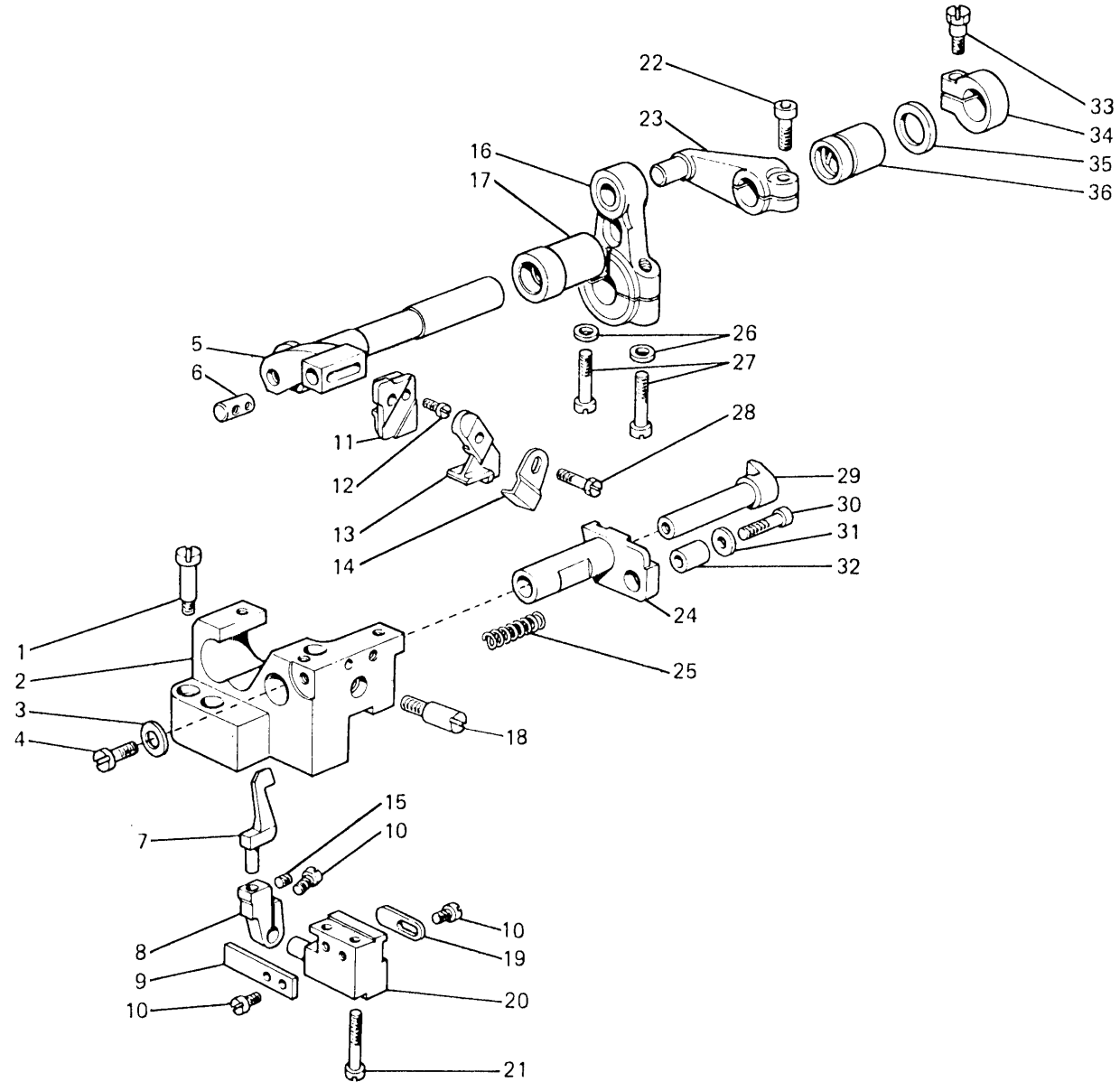

Fig. N.	Part. N. / Piece N.	Qt.
1	209175-3-00	1
2	209115-2-01	1
3	722453-2-00	1
4	729034-2-00	2
5	778419-0-00	1
6	729012-2-00	2
7	778504-0-00	1
8	745002-0-00	1
9	745812-2-00	3
10	209157-0-10	1
11	741967-2-00	2
12	313060-2-00	2
13	704853-0-00	1
14	211352-0-00	1
15	727036-2-00	1
16	209113-0-11	1
17	700560-0-00	1
18	211182-0-00	2
19	209199-0-00	1
20	209156-0-10	1
21	744334-2-00	1
22	211551-2-02	1
23	729013-2-00	1
24	730022-2-00	1
25	209106-2-02	1
26	704213-2-00	2
27	722149-2-00	2
28	211117-0-00	1
29	209143-0-01	1

Fig. N.	Part. N. Plece N.	Qt.
1	209587-0-00	2
2	209570-0-00	1
3	704409-2-00	1
4	742457-2-00	1
5	209561-0-01	1
6	202130-0-11	1
7	207997-0-00	1
8	207998-2-00	1
9	207991-0-00	1
10	741552-0-00	3
11	207588-0-01	1
12	744573-0-00	1
13	207653-0-01	1
14	209037-0-00	1
15	745812-2-00	1
16	210085-2-00	1
17	210093-0-00	1
18	209586-0-00	1
19	207999-0-00	1
20	208566-0-01	1
21	722480-2-00	2
22	744334-2-00	1
23	209581-2-01	1
24	207111-0-01	1
25	202128-0-10	1
26	704213-2-00	2
27	743469-2-00	2
28	207421-0-02	1
29	202134-0-11	1
30	722471-2-00	1
31	704406-2-00	1
32	202129-0-10	1
33	300482-0-10	1
34	209589-2-00	1
35	704863-0-00	1
36	209583-0-01	1



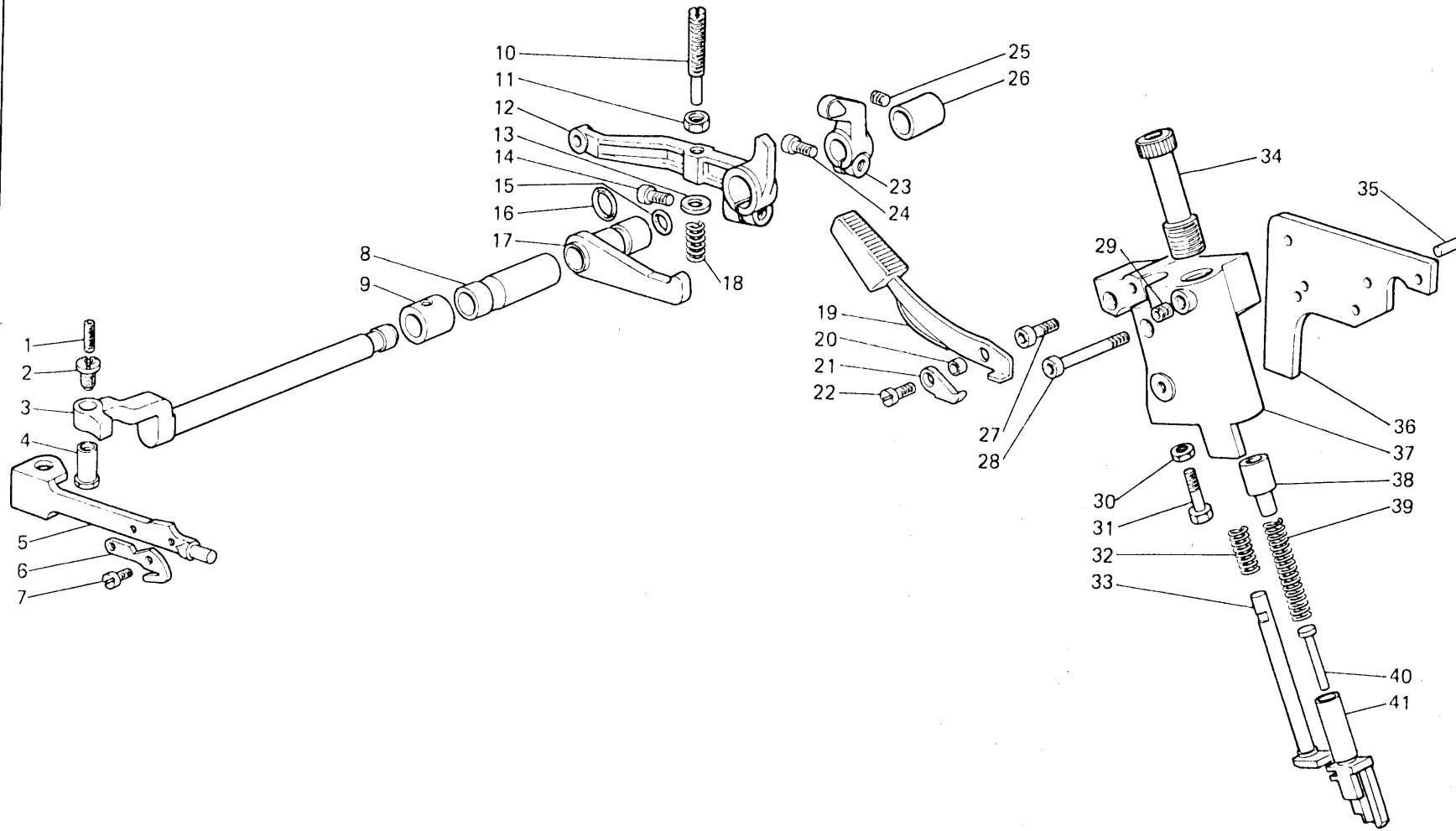
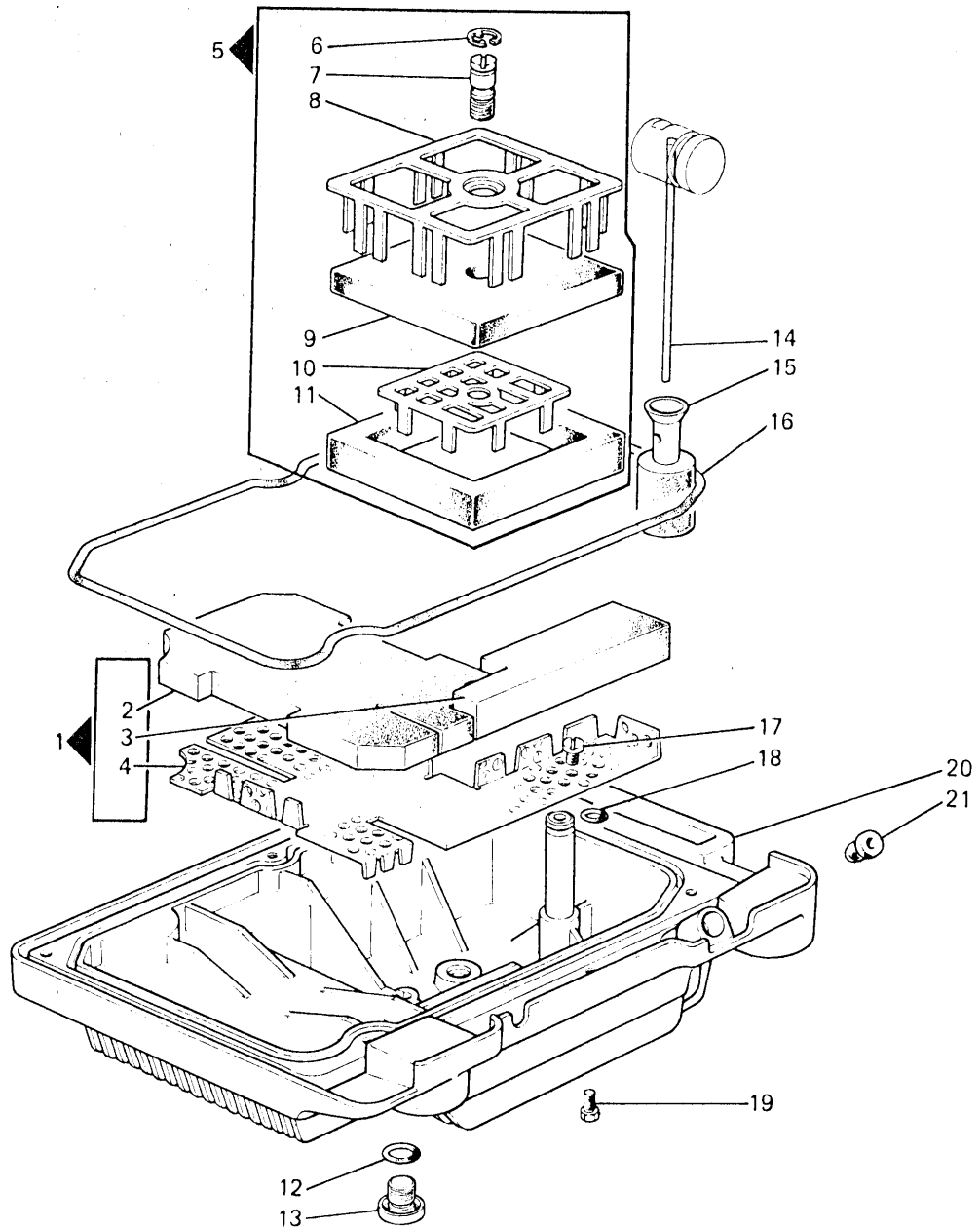

Fig. N.	Part. N. / Piece N.	Qt.
1	729031-2-00	1
2	202529-0-10	1
3	210036-0-00	1
4	206622-0-00	1
5	209512-0-00	1
6	202194-0-11	1
7	741433-2-00	2
8	210151-0-00	1
9	209209-0-00	1
10	210164-0-00	1
11	746204-2-00	1
12	210119-2-00	1
13	704213-2-00	1
14	722453-2-00	1
15	701110-0-00	1
16	701114-0-00	1
17	210117-0-00	1
18	209518-0-00	1
19	209524-2-00	1
20	206637-0-00	1
21	206635-0-00	1
22	722063-2-00	1
23	209502-2-01	1
24	744334-2-00	1
25	745812-2-00	1
26	209504-0-10	1
27	722153-2-00	1
28	722173-2-00	1
29	202391-0-11	1
30	746007-2-00	1
31	210088-0-00	1
32	926273-0-01	1
33	209507-0-00	1
34	207967-0-01	1
35	706495-0-00	2
36	210062-0-00	1
37	209505-0-01	1
38	209520-0-00	1
39	205021-0-10	1
40	209508-0-00	1
41	210060-0-00	1

Fig. N.	Part. N. / Piece N.	Qt.
1	209647-4-01	1
2	209645-0-01	1
3	209619-0-01	1
4	209644-0-02	1
5	209614-4-01	1
6	700211-0-00	1
7	209615-0-01	1
8	209616-0-01	1
9	209617-0-01	1
10	209611-0-01	1
11	209618-0-01	1
12	701015-0-00	1
13	321206-0-00	1
14	209624-0-11	1
15	206665-2-00	1
16	211013-0-00	1
17	721434-2-00	1
18	701006-0-00	1
19	720411-2-00	1
20	209048-3-10	1
21	211675-0-00	1



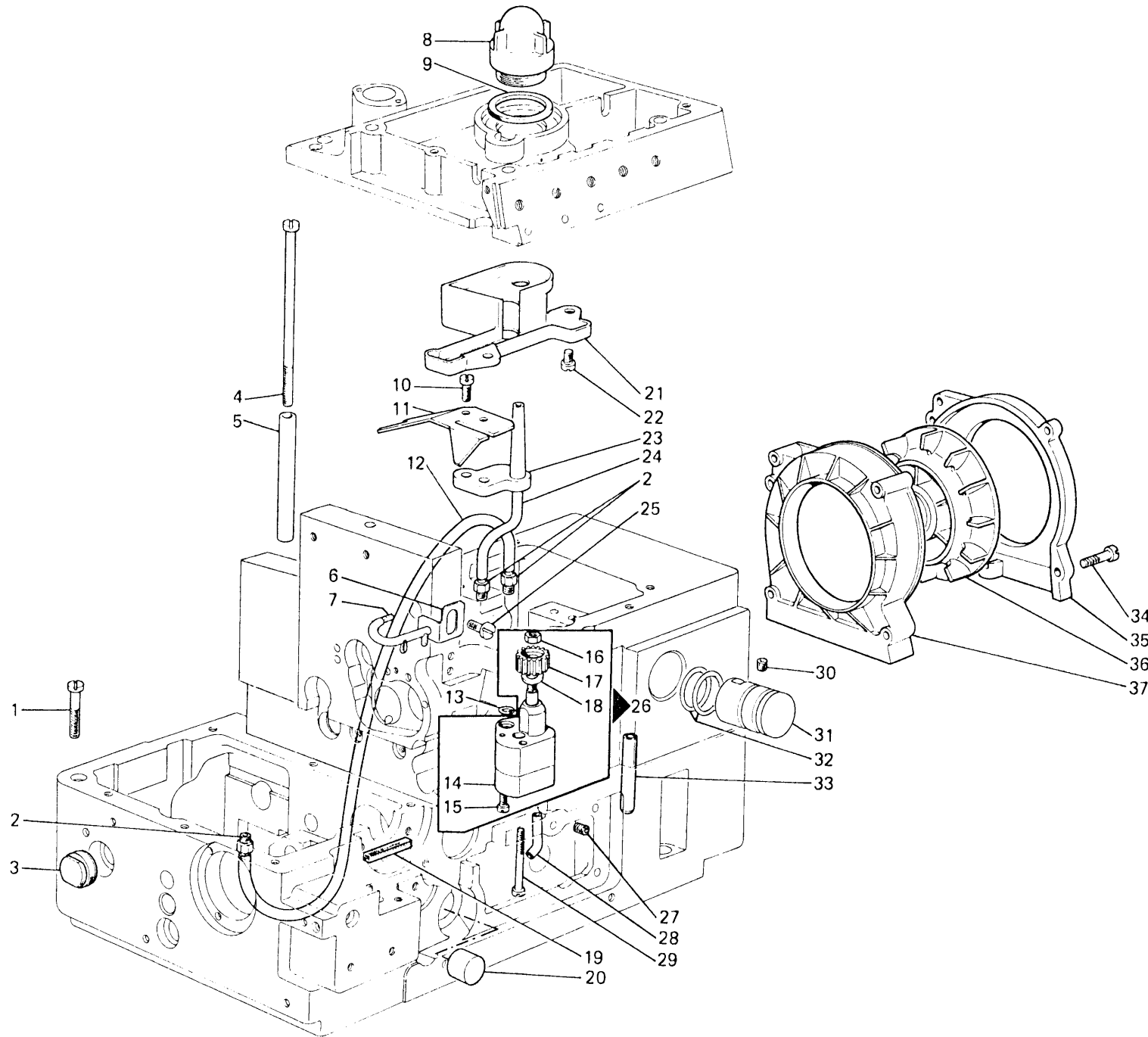
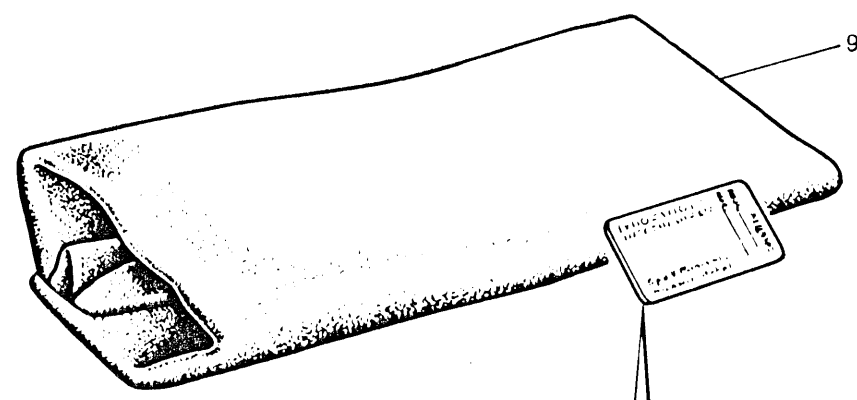
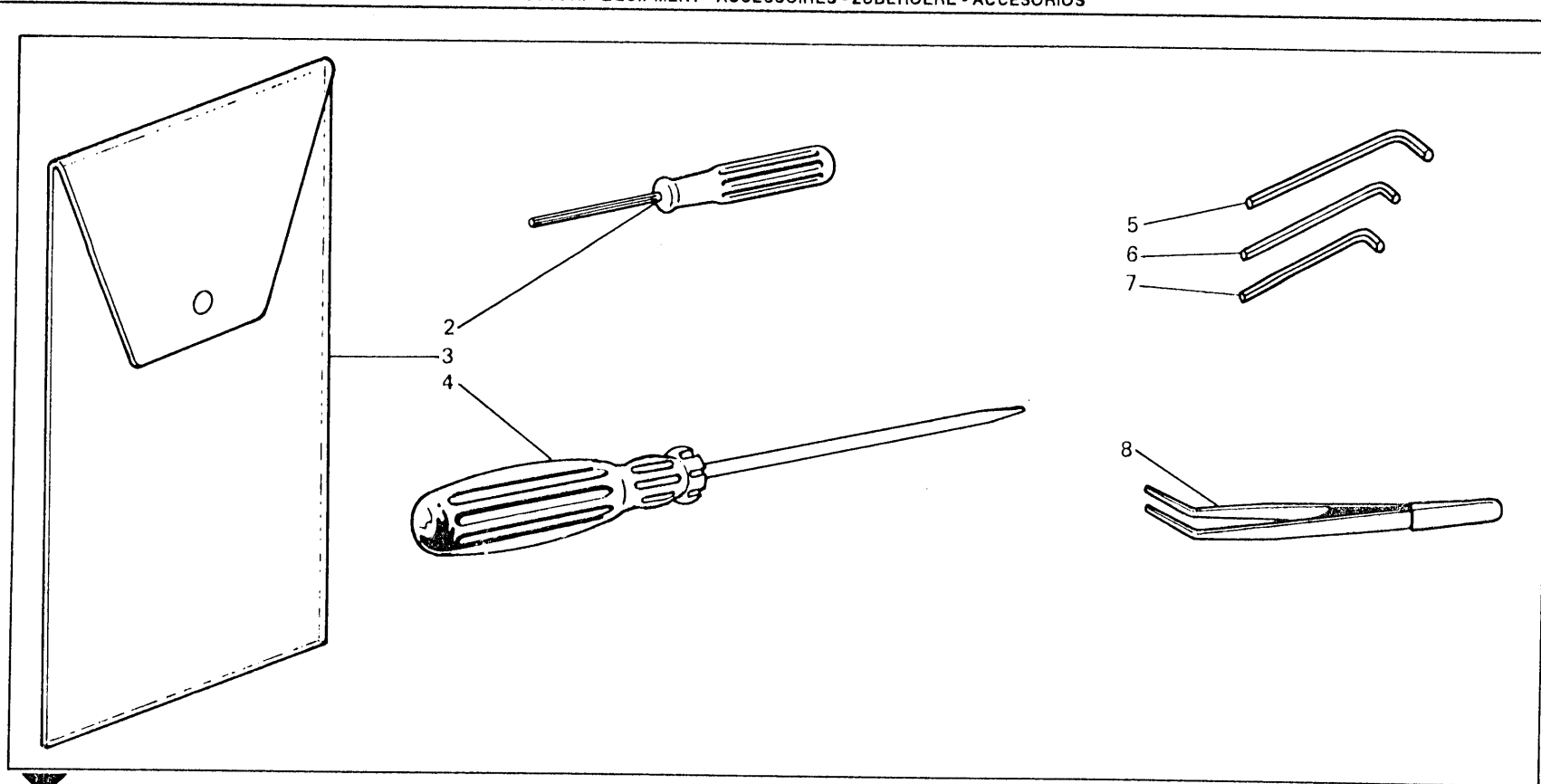

Fig. N.	Part. N. Piece N.	Qt.
1	742086-2-00	4
2	209641-0-00	3
3	211414-0-00	1
4	207917-0-00	1
5	210069-0-00	1
6	211630-4-00	1
7	778526-0-00	1
8	207973-0-01	1
9	705970-0-00	1
10	721494-2-00	2
11	210165-0-01	1
12	790719-0-00	1
13	701004-0-00	1
14	206554-0-10	1
15	741387-2-00	2
16	733507-2-00	1
17	206437-0-00	1
18	704813-0-00	1
19	209383-0-00	1
20	209316-0-00	1
21	210073-0-00	1
22	722063-2-00	2
23	209628-0-00	1
24	790705-0-00	1
25	742222-2-00	1
26	206550-4-05	1
27	745812-2-00	1
28	211594-0-00	1
29	722511-2-00	2
30	729022-2-00	1
31	209621-3-12	1
32	701031-0-00	2
33	209627-0-00	1
34	722143-2-00	4
35	206687-2-00	1
36	206690-2-00	1
37	206688-0-00	1



Fig. N.	Part. N. / Piece N.	Qt.
1	991400-4-03	1
2	990474-0-11	1
3	991415-0-00	1
4	990723-0-00	1
5	990639-0-10	1
6	990685-0-10	1
7	990325-0-10	1
8	990176-0-10	1
9	990979-0-00	1
10	991512-0-01	1



Per l'ordinazione della bustina aghi citare lo stesso simbolo dell'ago montato sulla testa.

To order packet of needles please specify symbol of needle fitted on machine.

Pour commander un sachet d'aiguilles donner le symbol de l'aiguille montee sur la tête.

Un die Nadeinpackung zu bestellen bitte das gleiche Nadelsymbol wie die an Naehekopf umgebauete Nadel zu geben.

Para el pedido de un paquete de agujas, citar el mismo simbolo de la aguja montada en el cabezal.

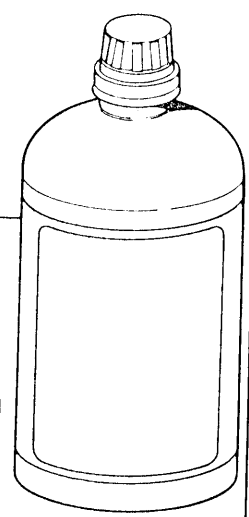

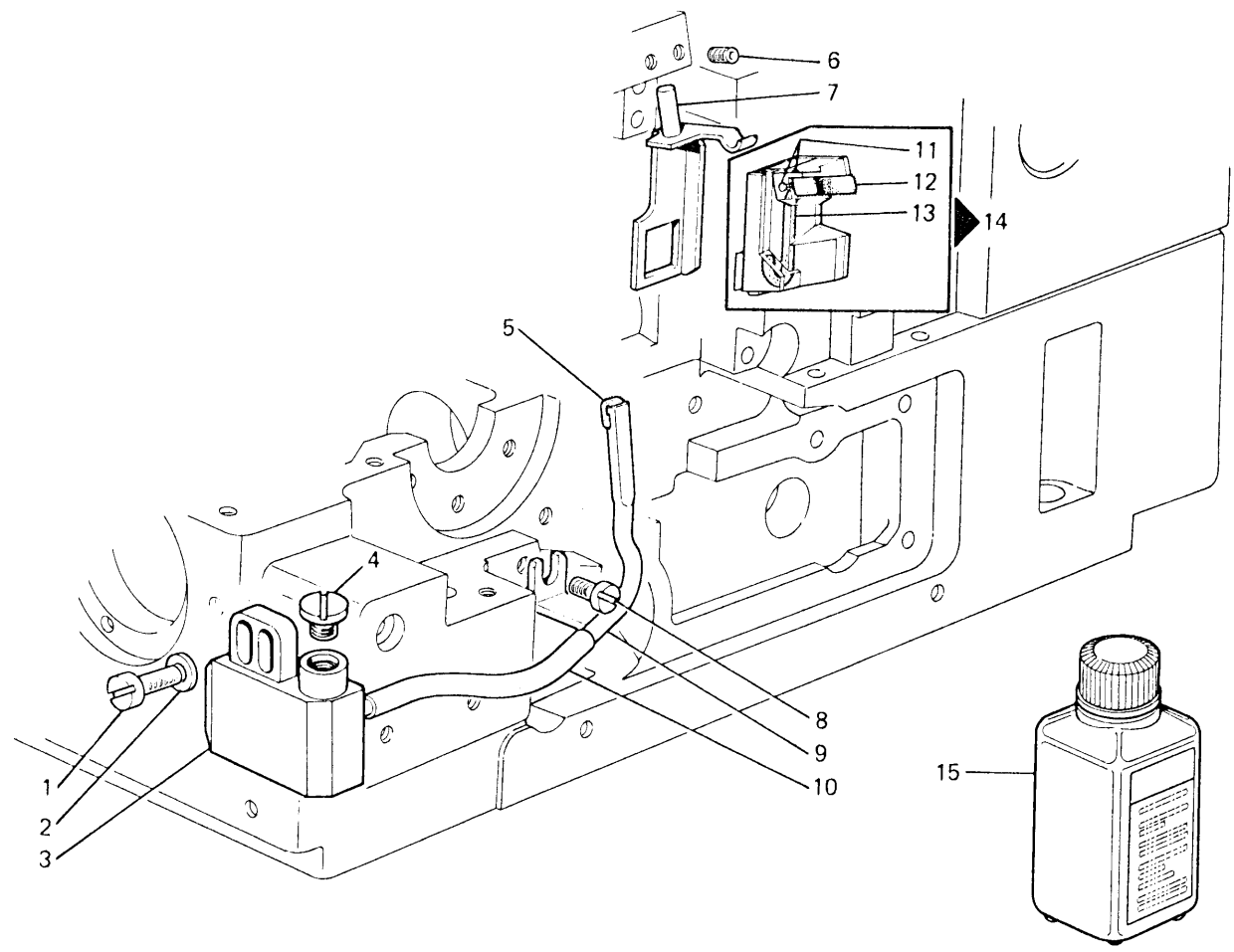

Fig. N.	Part. N. Piece N.	Qt.
1	721474-2-00	1
2	704211-2-00	1
3	211611-0-00	1
4	207969-0-00	1
5	209667-0-00	1
6	745800-2-00	1
7	210109-2-00	1
8	741936-2-00	1
9	209655-4-00	1
10	208207-0-00	1
11	200490-0-00	2
12	209664-0-00	1
13	778419-0-00	1
14	209662-4-00	1
15	990934-0-00	1

A RICHIESTA - ON REQUEST - SUR DEMANDE - AUF ANFRAGE - CON SOLICITUD

# Rim® TAV. 17

PIAZZAMENTO INCASSATO - SUBMERGED SETTING - PLACEMENT ENCASTRE - VERSENKTE AUFSTELLUNG - COLOCACION SUMERGIDA

Fig. N.	Part. N. Plece N.	Qt.
1	722912-2-00	2
2	704346-2-00	14
3	901152-0-00	2
4	901101-0-00	8
5	901151-0-00	2
6	901102-0-00	4
7	733008-2-00	10
8	720546-2-00	2
9	990311-0-10	3
10	990314-0-10	1
11	700205-0-00	3
12	746402-2-00	2
13	990310-0-10	2
14	990312-0-10	1
15	900204-0-10	1
16	746409-2-00	1
17	704424-2-00	1
18	990988-0-00	4
19	900694-0-11	4
20	991349-0-00	1
21	990179-4-11	1
22	704013-2-00	4
23	722920-2-00	2
24	991188-0-02	1
25	901153-0-00	2
26	991750-0-01	1
27	900203-0-10	4
28	721475-2-00	2
29	704409-2-00	2

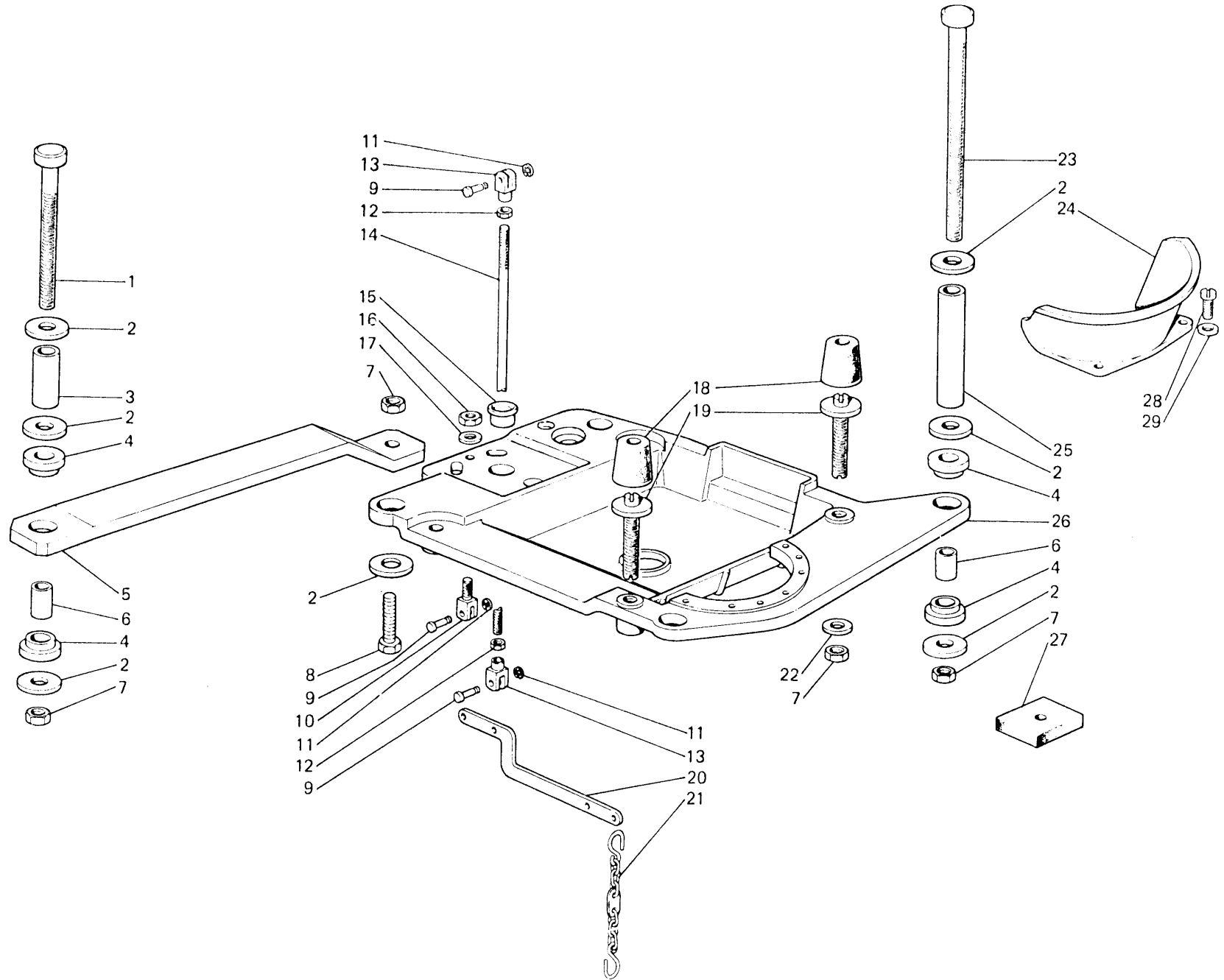

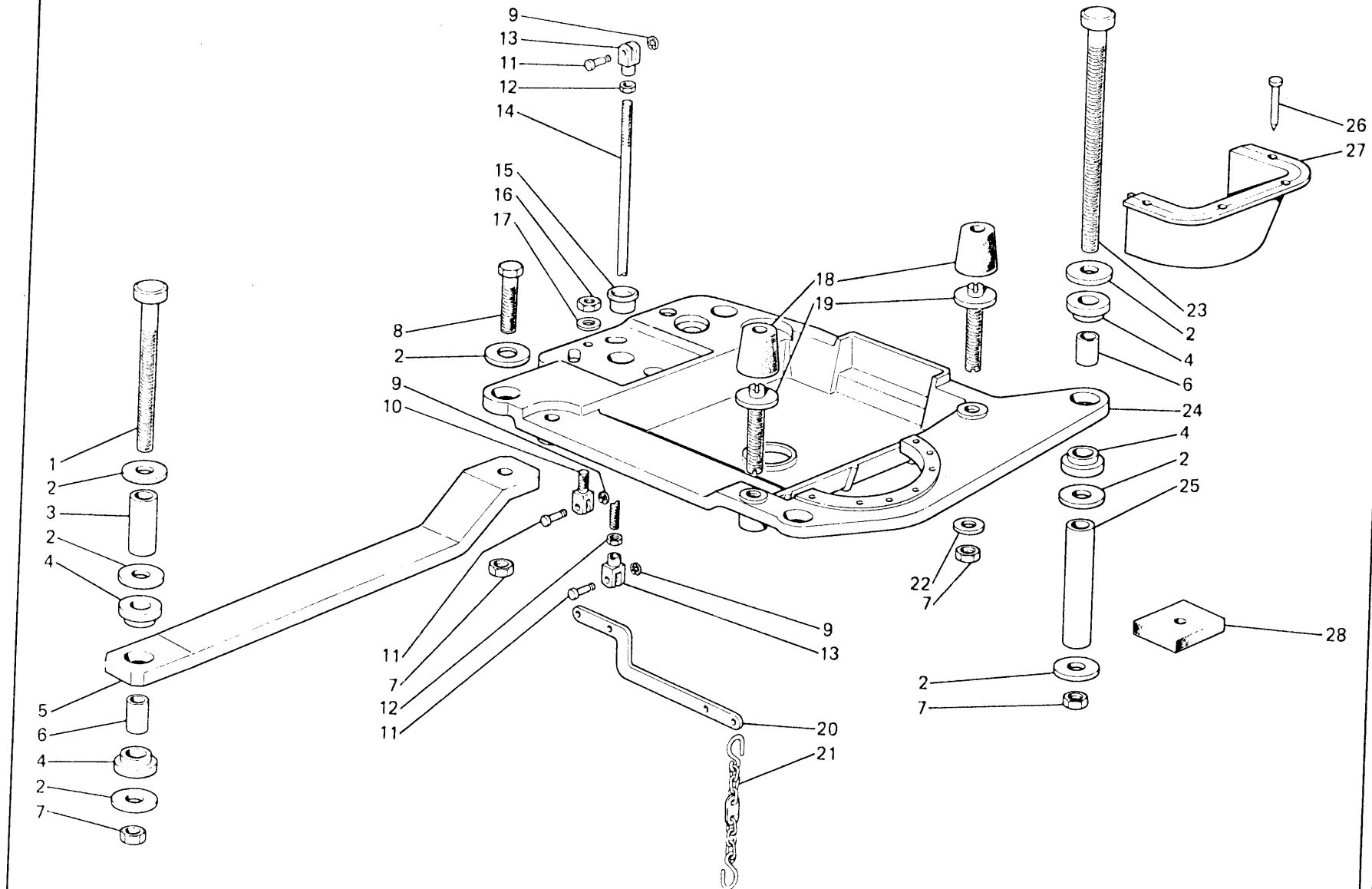
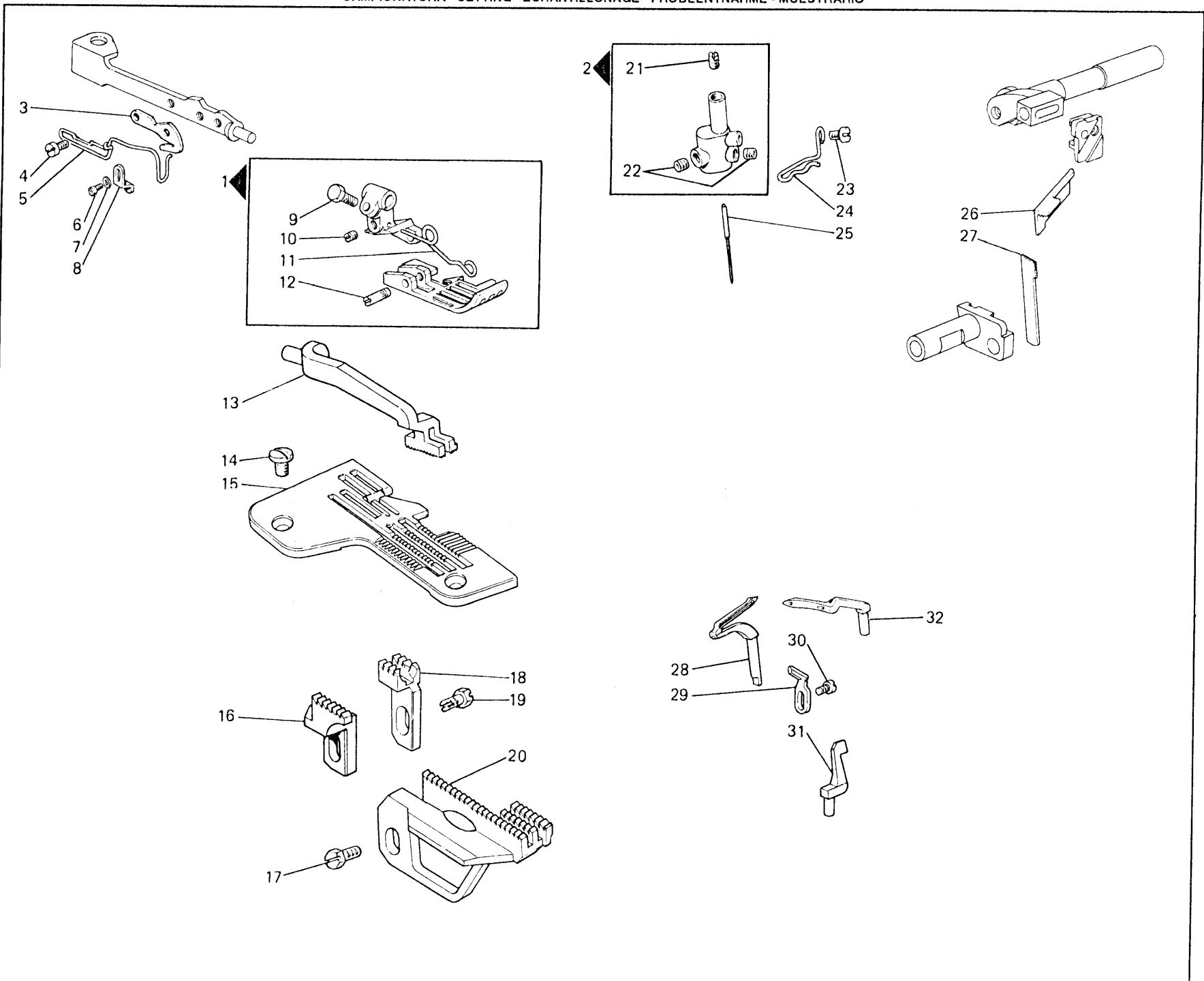

Fig. N.	Part. N. / Pieca N.	Qt.
1	722912-2-00	2
2	704346-2-00	14
3	901152-0-00	2
4	901101-0-00	8
5	901151-0-00	2
6	901102-0-00	4
7	733008-2-00	10
8	720546-2-00	2
9	700205-0-00	3
10	990314-0-10	1
11	990311-0-10	3
12	746402-2-00	2
13	990310-0-10	2
14	990312-0-10	1
15	900204-0-10	1
16	746409-2-00	1
17	704424-2-00	1
18	990988-0-00	4
19	900694-0-11	4
20	991349-0-00	1
21	990179-4-11	1
22	704013-2-00	4
23	722920-2-00	2
24	991750-0-01	1
25	901153-0-00	2
26	M488972020	
27	991187-0-01	1
28	900203-0-10	4

Fig. N.	Part. N. Pleca N.	Qt.
1	210244-3-00	1
2	211613-2-00	1
3	202194-0-11	1
4	741433-2-00	2
5	990694-0-01	1
6	741658-2-00	1
7	704004-0-00	1
8	206771-0-12	1
9	204947-0-10	1
10	745800-2-00	1
11	210099-0-00	1
12	207554-0-00	1
13	210202-0-00	1
14	744742-2-00	2
15	210208-0-00	1
16	210206-0-00	1
17	202489-0-10	1
18	946040-0-00	1
19	202488-0-10	1
20	210207-0-00	1
21	727021-0-00	1
22	745810-2-00	2
23	741415-2-00	1
24	207542-0-00	1
25	765200-6-10	---
26	209342-0-00	1
27	209344-2-00	1
28	209267-0-01	1
29	209477-0-01	1
30	741538-2-00	2
31	207997-0-00	1
32	209223-0-01	1



A RICHIESTA  
ON REQUEST  
SUR DEMANDE  
AUF ANFRAGE  
CON SOLICITUD

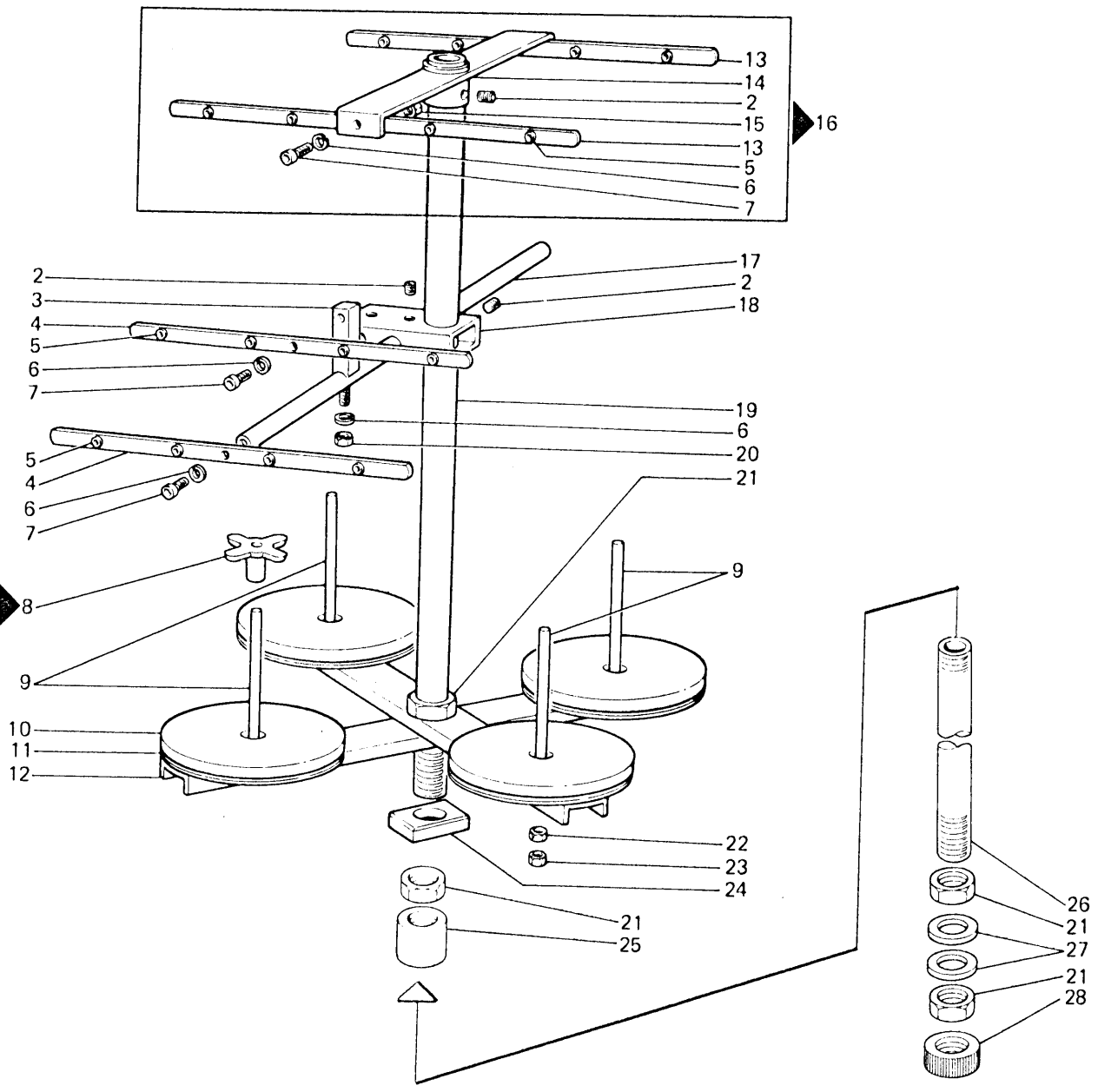

Fig. N.	Part. N. / Piece N.	Qt.
1	991120-5-02	1
2	729034-2-00	3
3	991269-2-00	1
4	991108-2-01	2
5	991268-0-00	16
6	703005-0-00	5
7	722431-2-00	4
8	991134-0-00	4
9	991111-2-00	4
10	991179-0-01	4
11	991112-0-00	4
12	991199-0-00	2
13	991126-0-10	2
14	991247-2-00	1
15	733505-2-00	2
16	991194-4-00	1
17	991264-2-00	1
18	991279-2-00	1
19	991206-0-00	1
20	733806-0-00	1
21	733211-2-00	4
22	733508-2-00	4
23	925433-0-00	4
24	991172-0-00	2
25	991219-0-00	1
26	991267-0-00	1
27	704017-2-00	2
28	991383-0-10	1

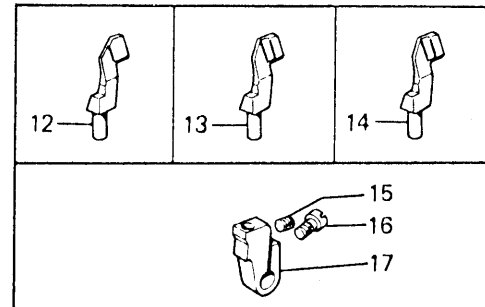
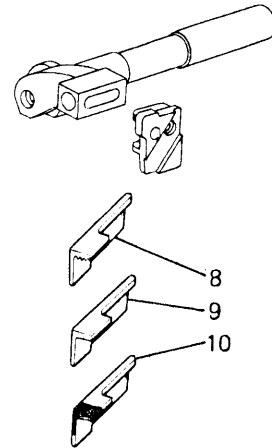
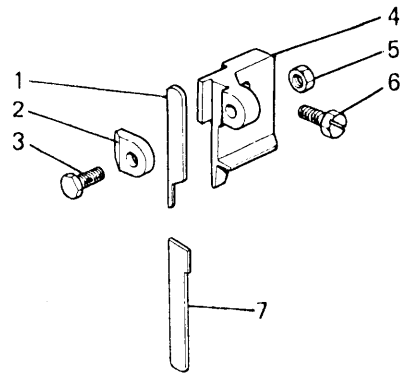

Fig. N.	Part. N. / Piece N.	Qt.
1	202629-0-10	1
2	202620-0-10	1
3	205191-0-10	1
4	209590-0-00	1
5	733504-2-00	1
6	203525-0-11	1
7	203012-0-10	2
8	203759-0-10	2
9	203783-0-10	2
10	207003-2-00	1
11	209245-0-00	1
12	207992-0-01	1
13	207993-0-01	1
14	207994-0-01	1
15	745812-2-00	1
16	741552-0-00	1
17	207998-2-00	1