

1a EDIZIONE-EDITION 12/90 **n. 531**

**MACCHINE
MACHINES
MACHINES
MASCHINEN
MAQUINAS**

**BL4-738
738DF**

SOMMARIO - SUMMARY

TAV.	DESCRIZIONE	DESCRIPTION
1.	Base e Bacinella olio	Base Plate, and Oil Wick
2.	Coperchi	Covers
3.	Puller	Machine Pulley
4.	Porta Bobine	Spool Stand Components
5.	Frontale e Gruppo Tensioni	Face Plate and Tension Adjuster
6.	Barra Ago	Needle Bar Components
7.	Crochet Superiore	Upper Looper Components
8.	Crochet Inferiore	Lower Looper Components
9.	Meccanismi Trasporto Differenziale (738 D)	Differential Feed Mechanism Components (738D)
10.	Piedino e Placca Ago	Presser Foot Components and Needle Plate
11.	Coltello Superiore	Upper Knife Components
12.	Regolazione Larghezza Costa e Coltello Inferiore	Seam Width Adjusting Components and Lower Knife Components
13.	Lampada	Lamp Components
14.	Motore e Pedale	Motor and Controller Components
15.	Accessori in Dotazione	Standard Accessories

2. Covers

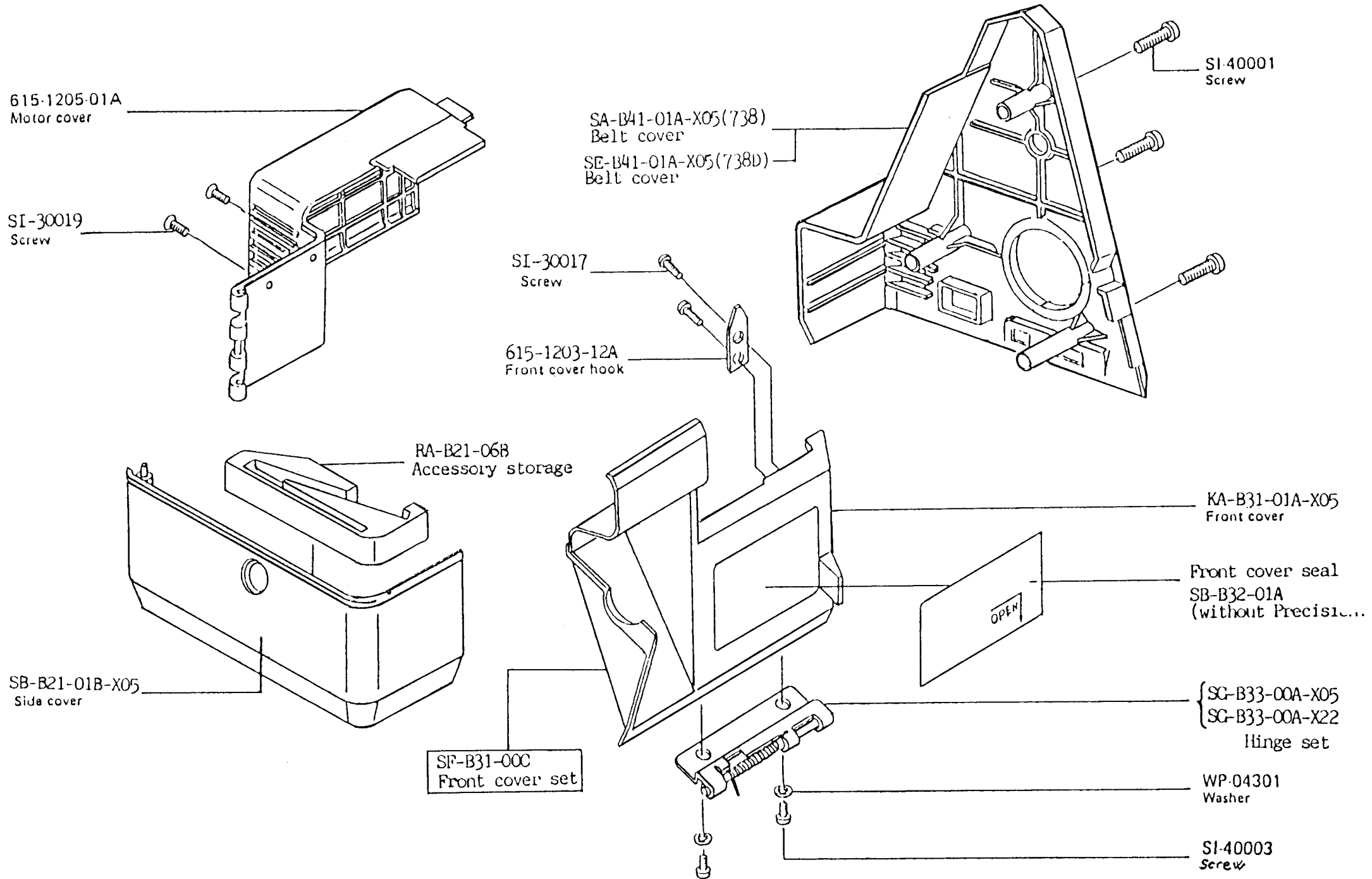

3. Machine pulley

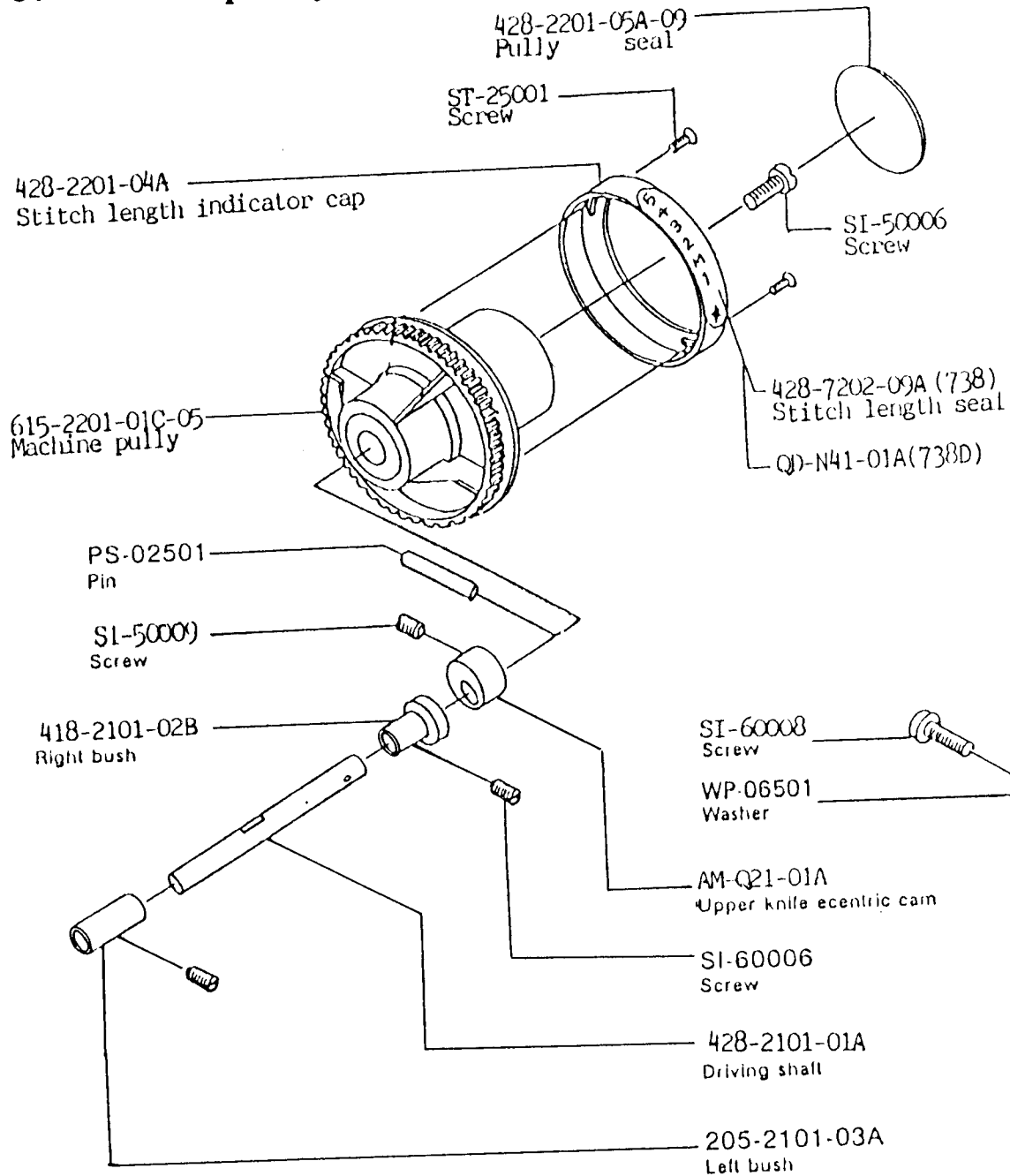

4. Spool stand components

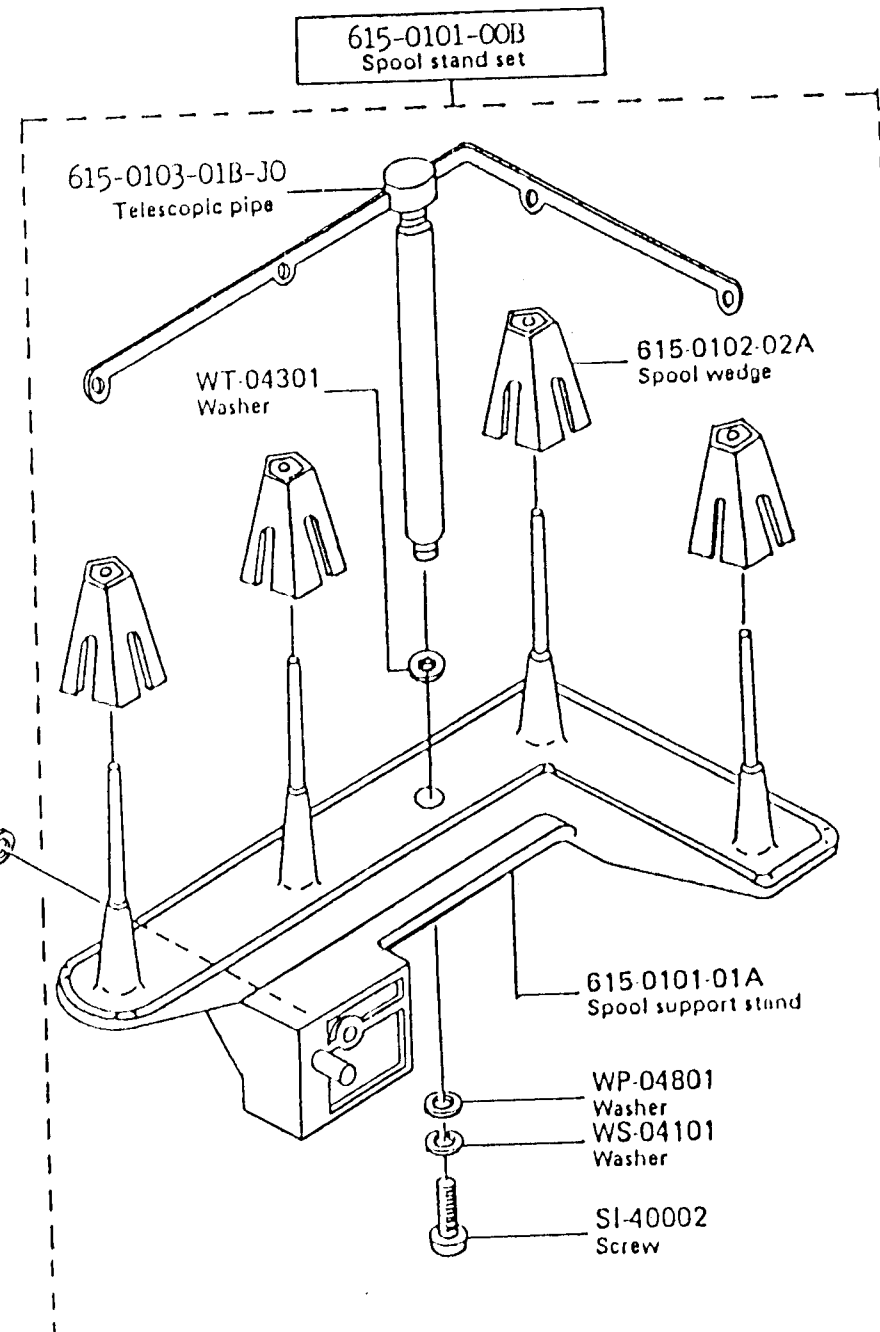

5. Face plate and Tension adjuster

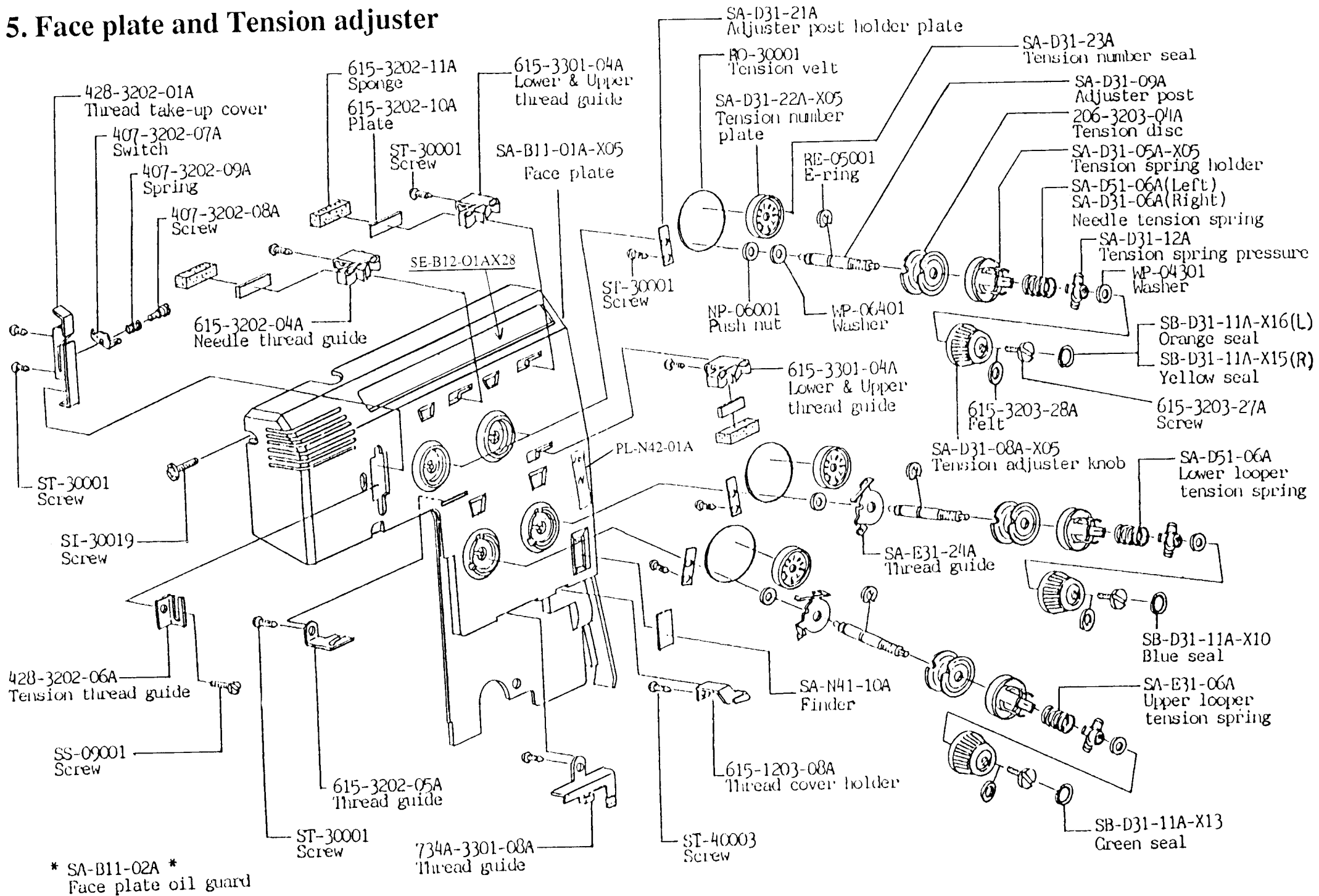

6. Needle bar components

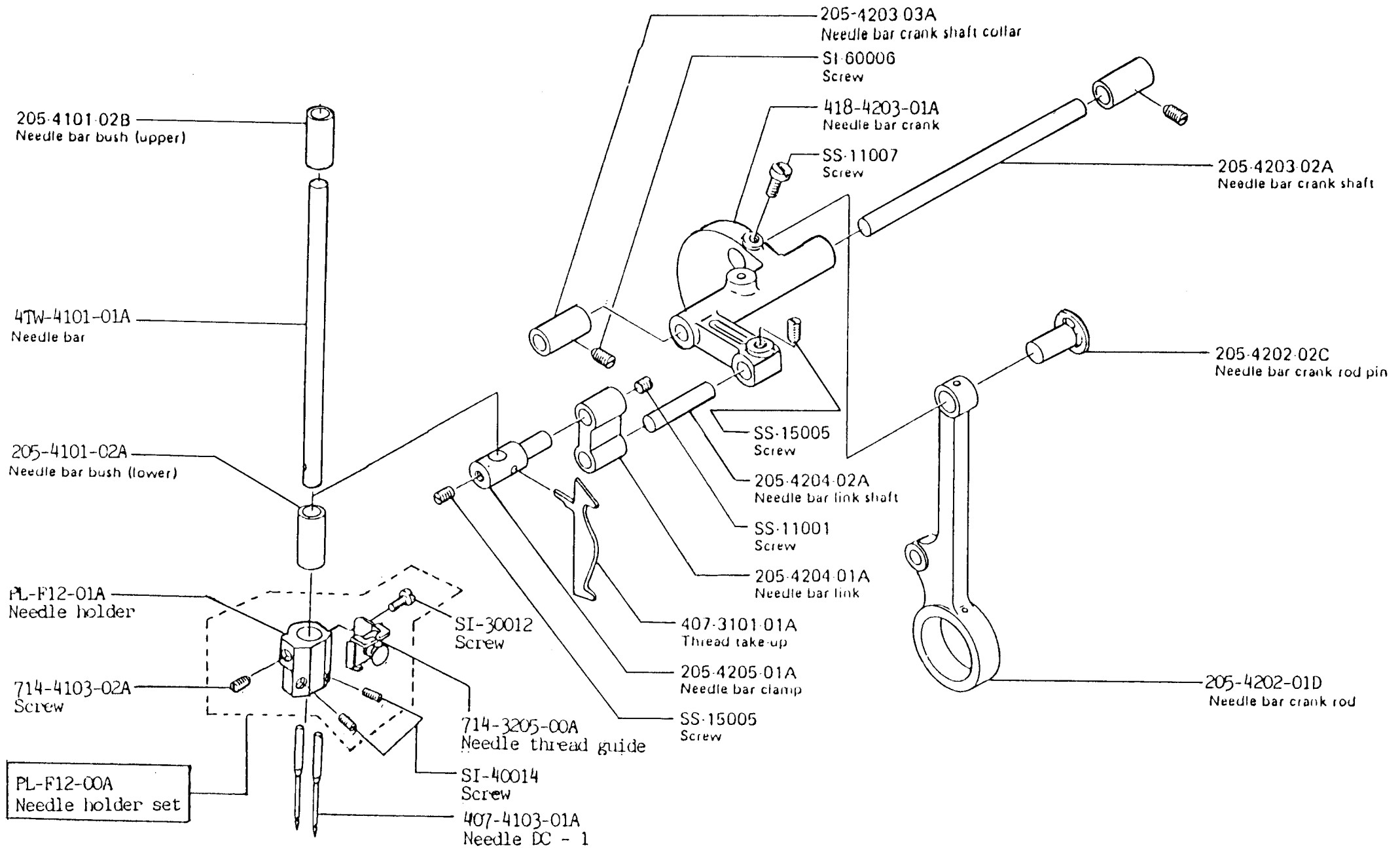

7. Upper looper components

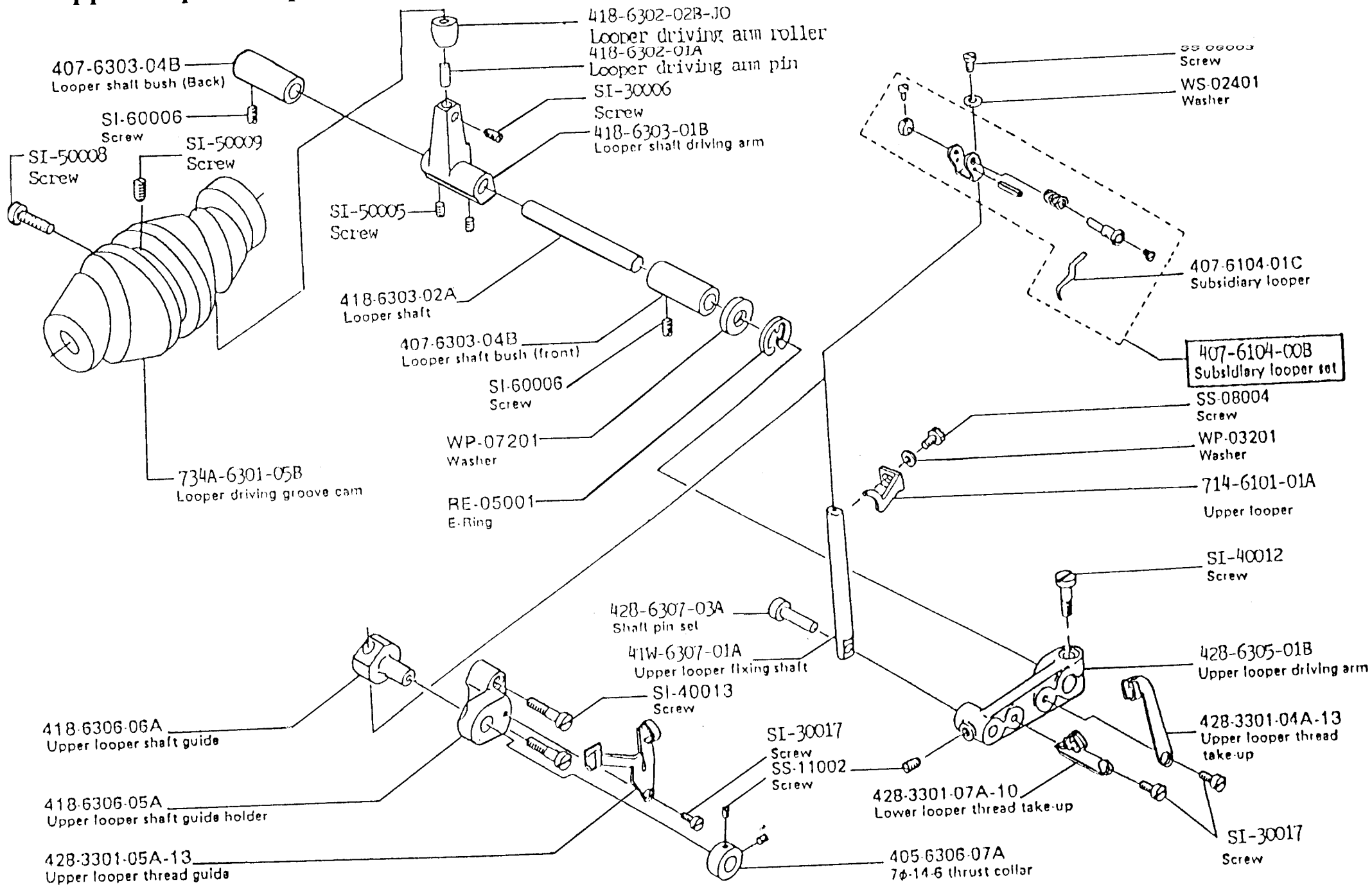

8. Lower looper components

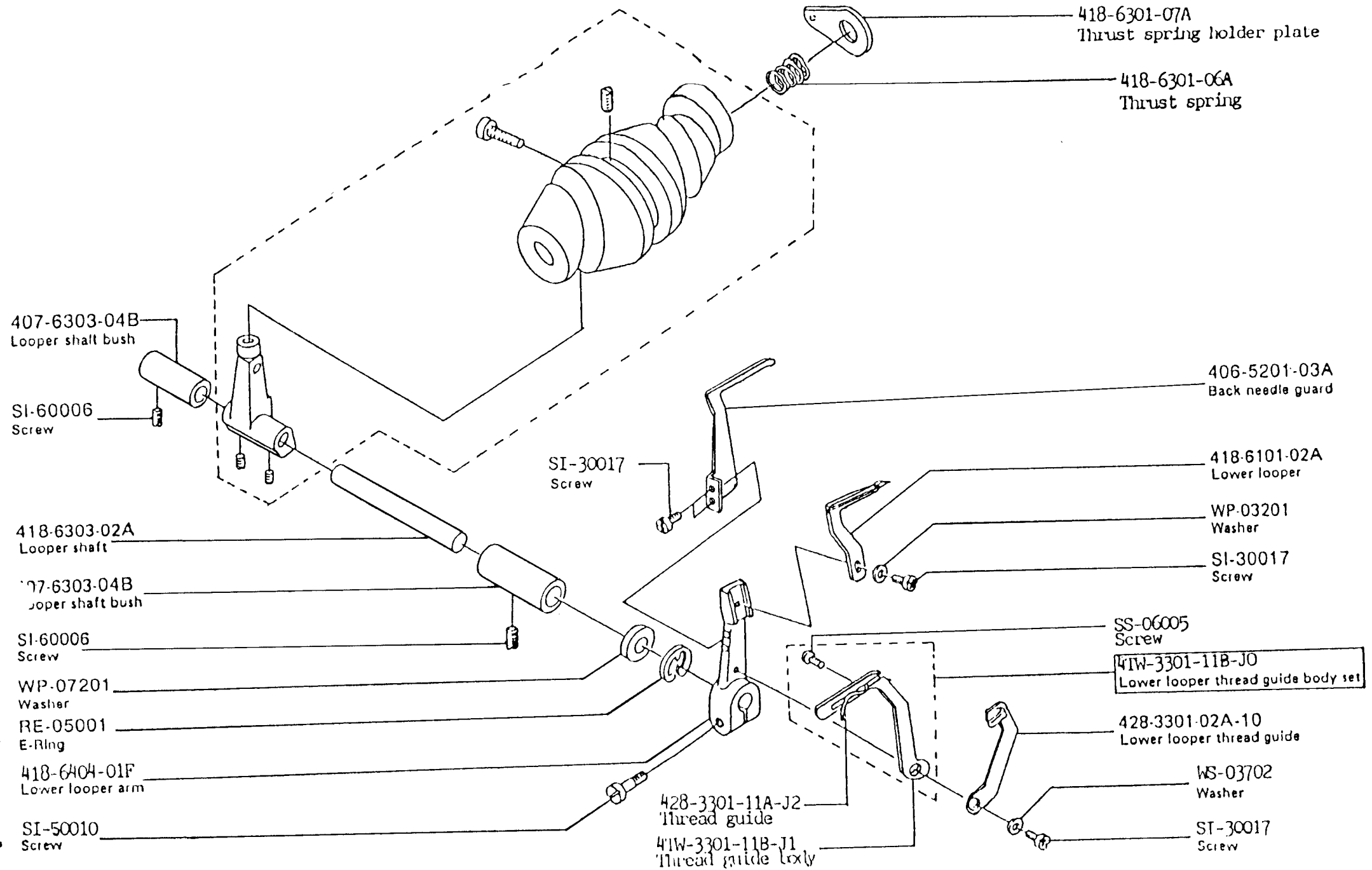

9. Differential Feed mechanism components (738D)

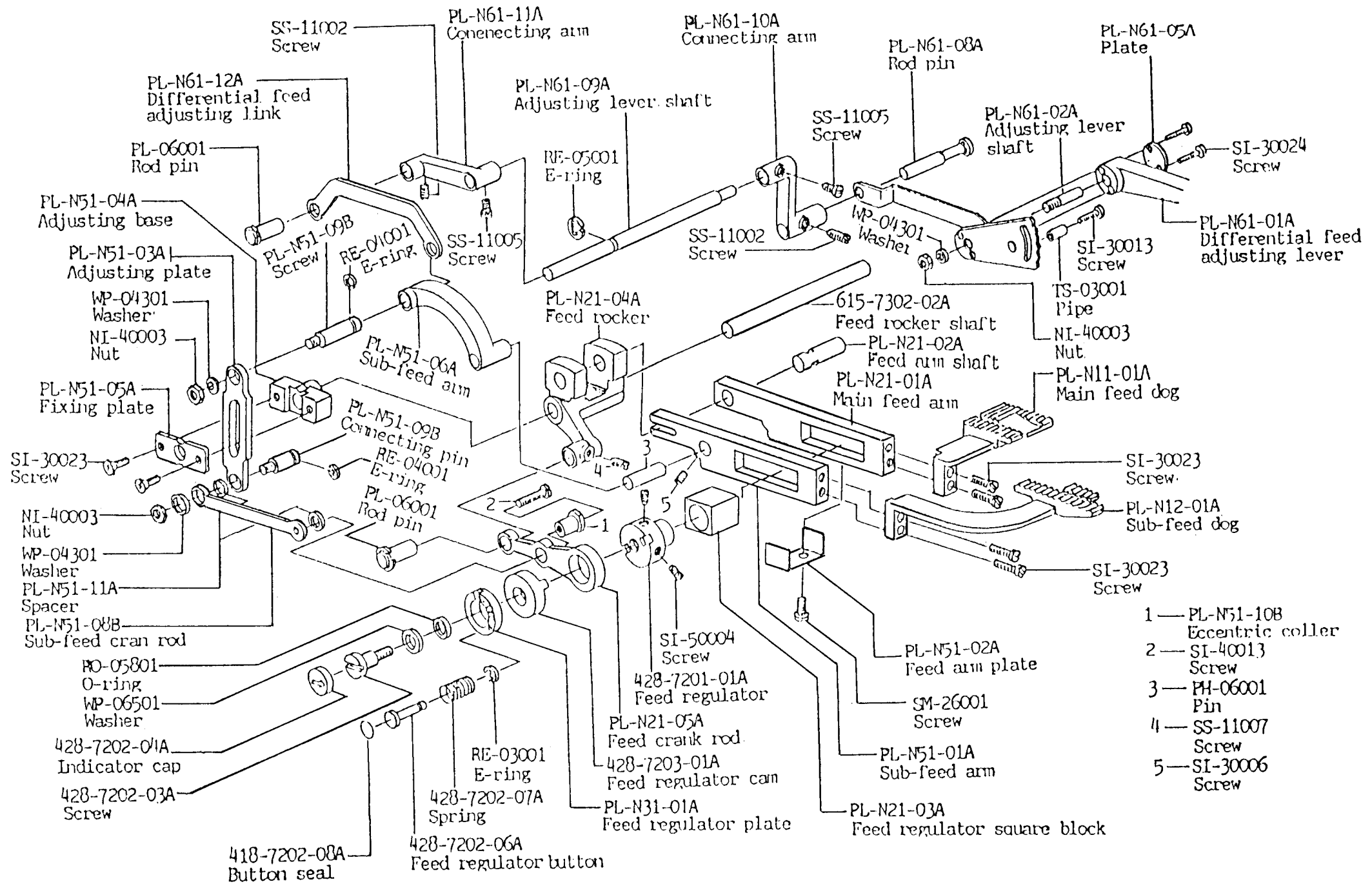

10. Presser foot components and Needle plate

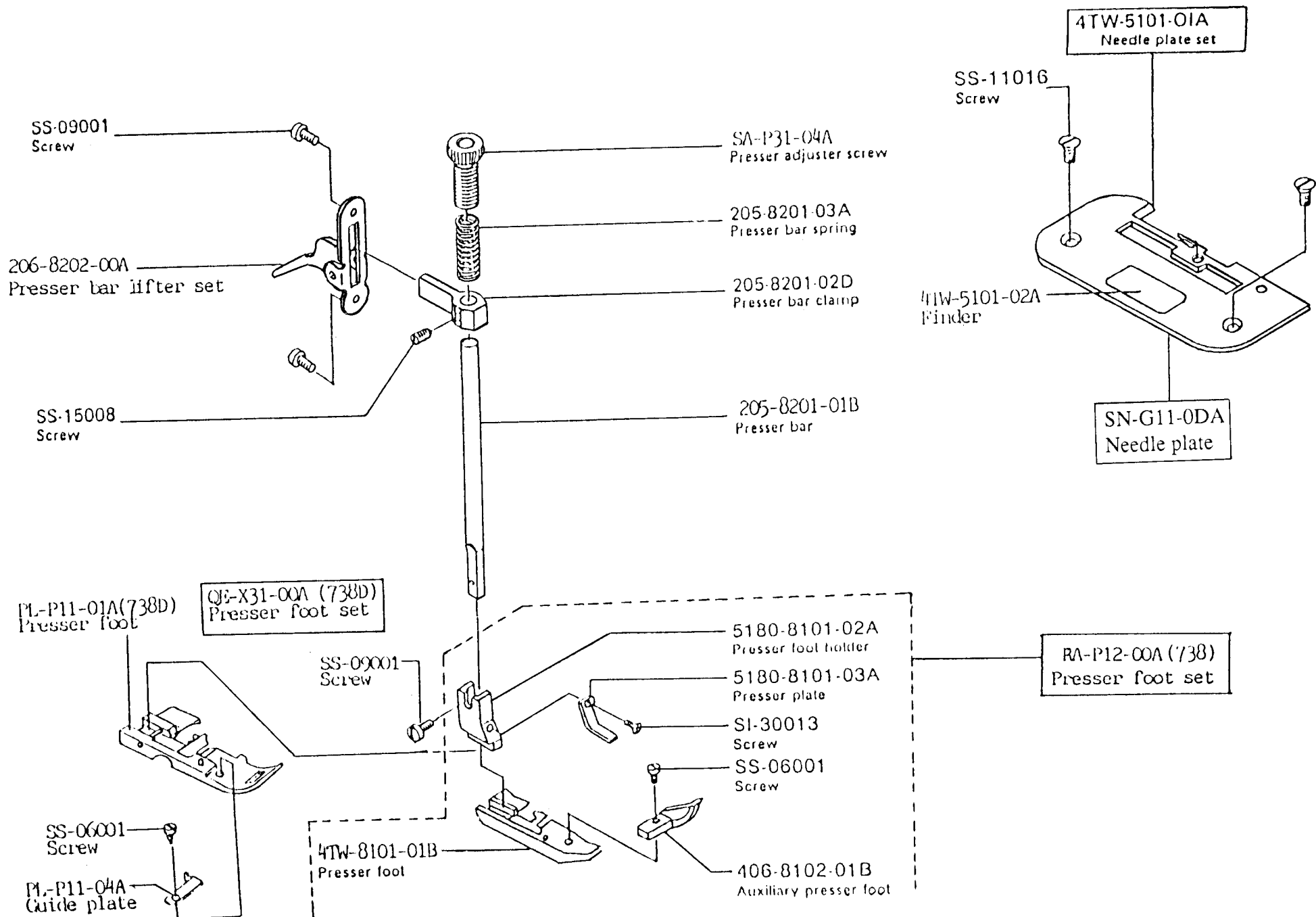

11. Upper knife components

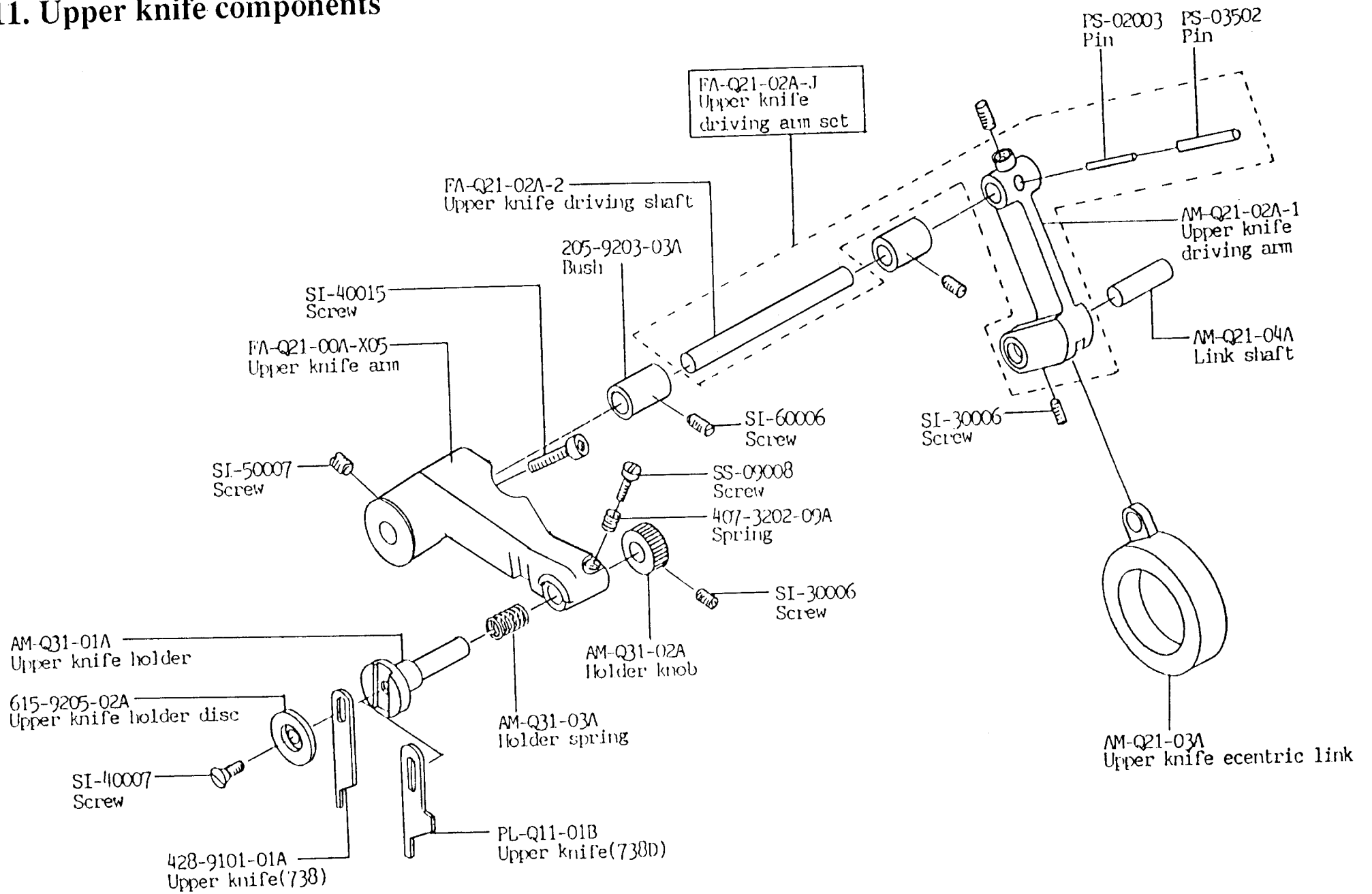

12. Seam width adjusting components and Lower knife components

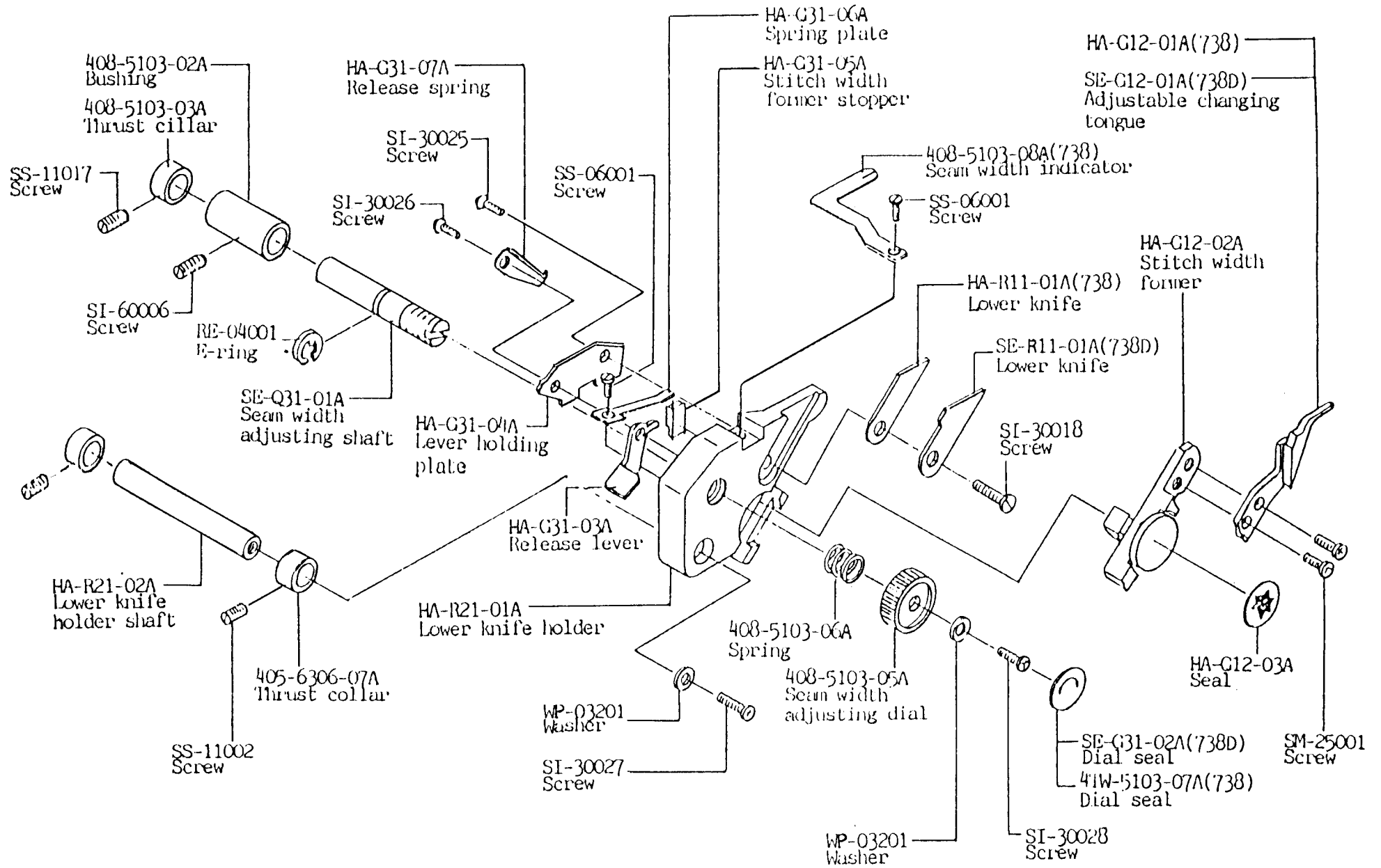

13. Lamp components

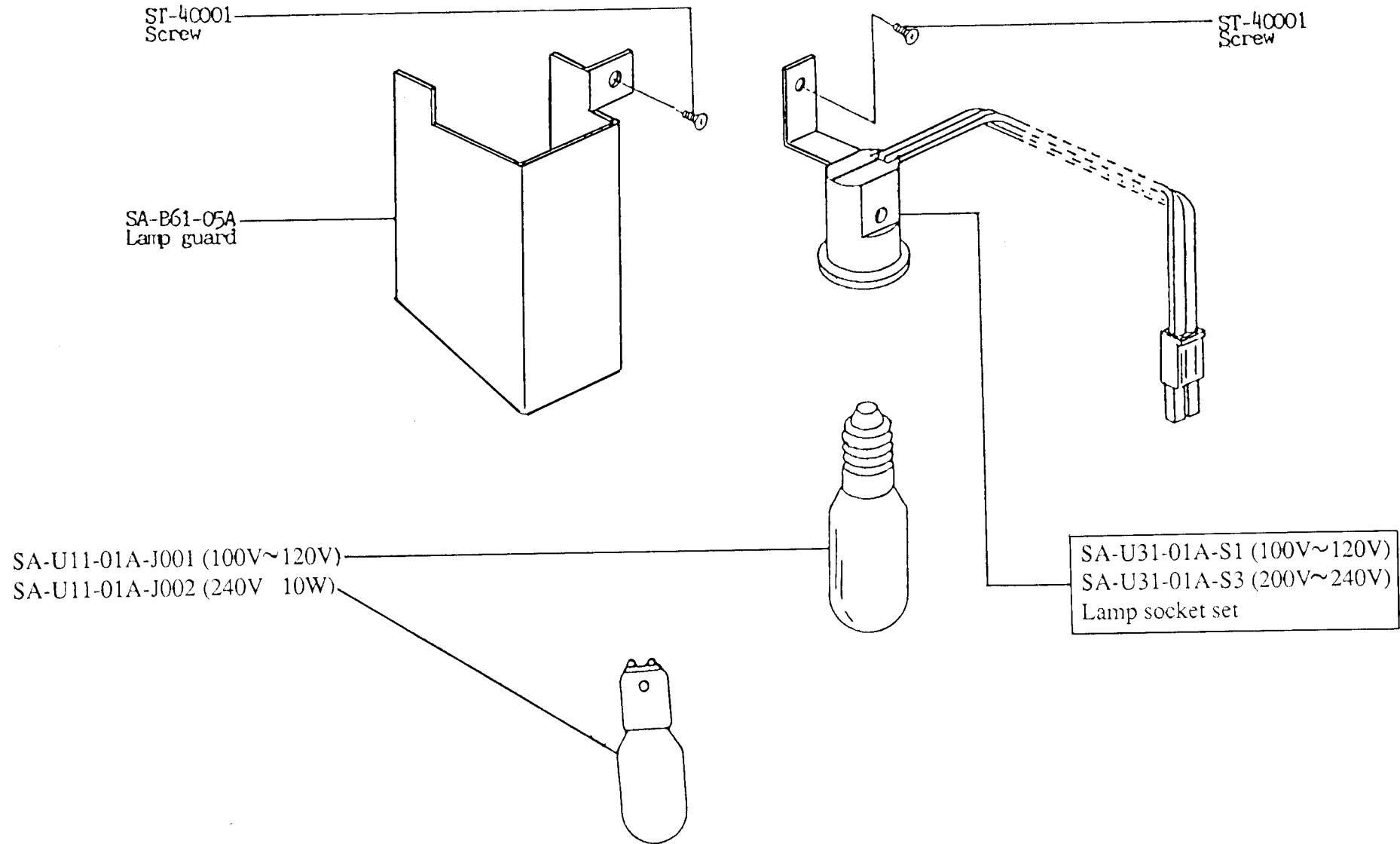

14. Motor and Controller components

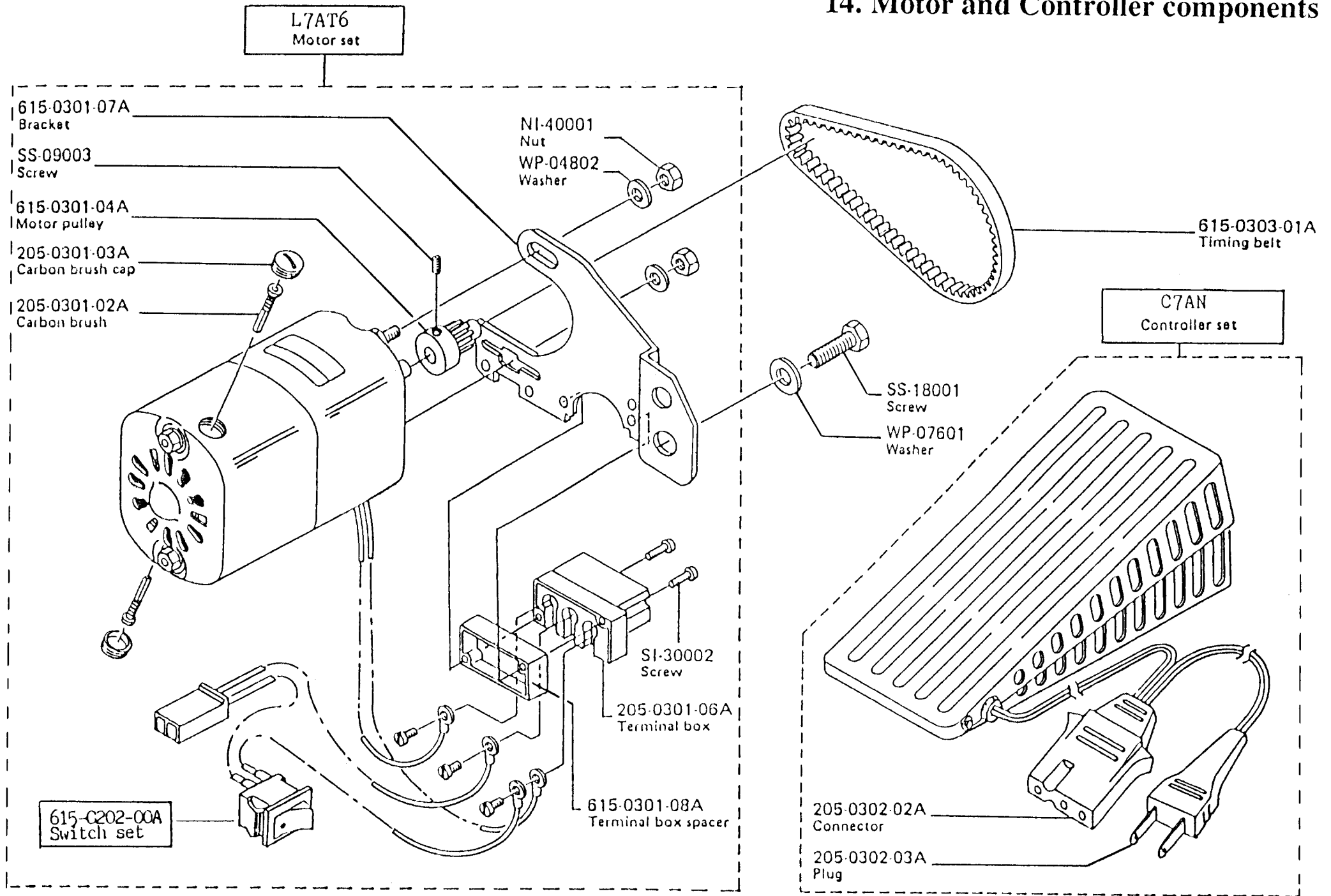

15. Standard accessories

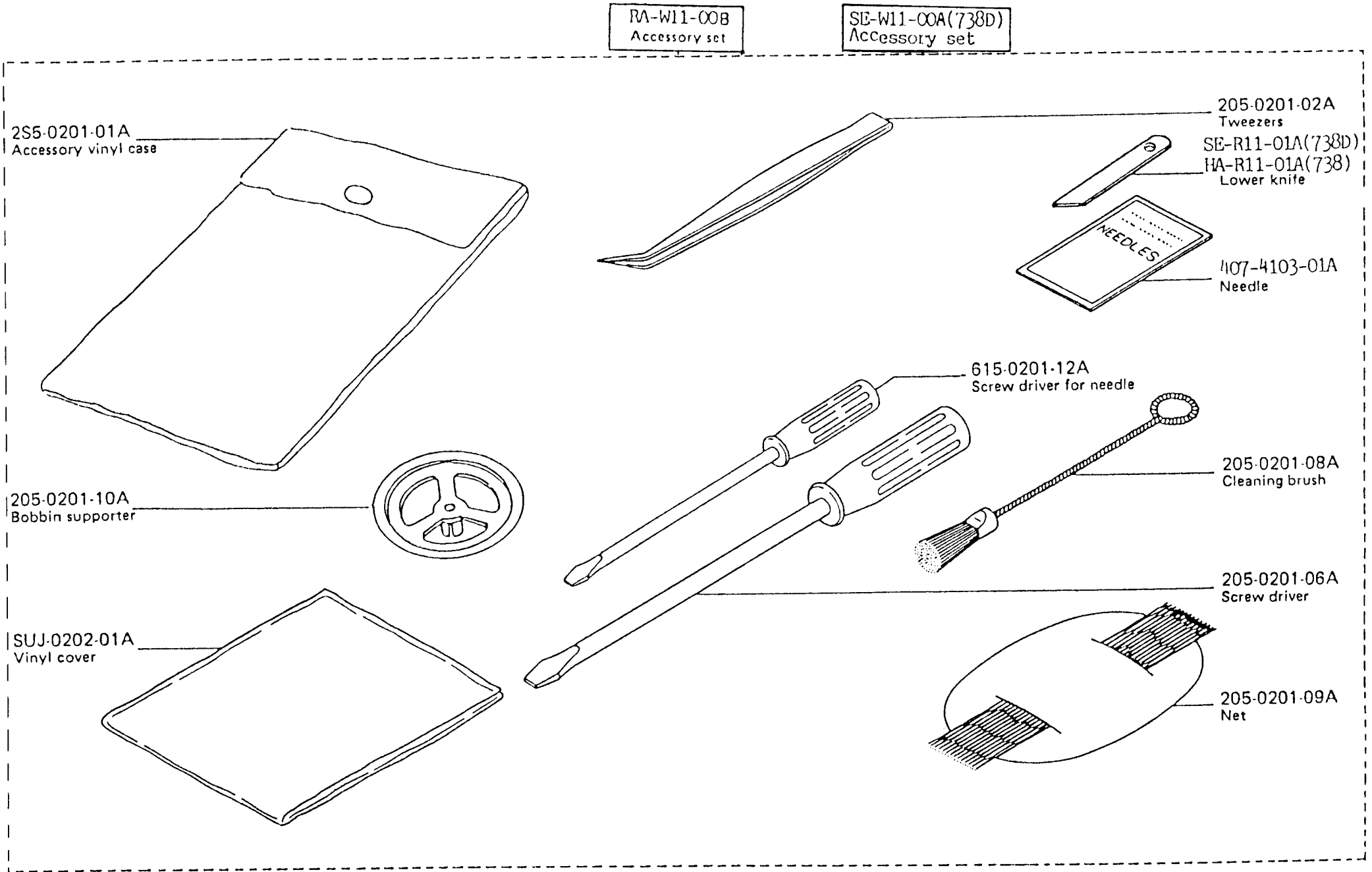

Rimoldi®

CATALOGO PEZZI DI RICAMBIO Rim®

Rim® SPARE PARTS CATALOGUE

CATALOGUE RECHANGES Rim®

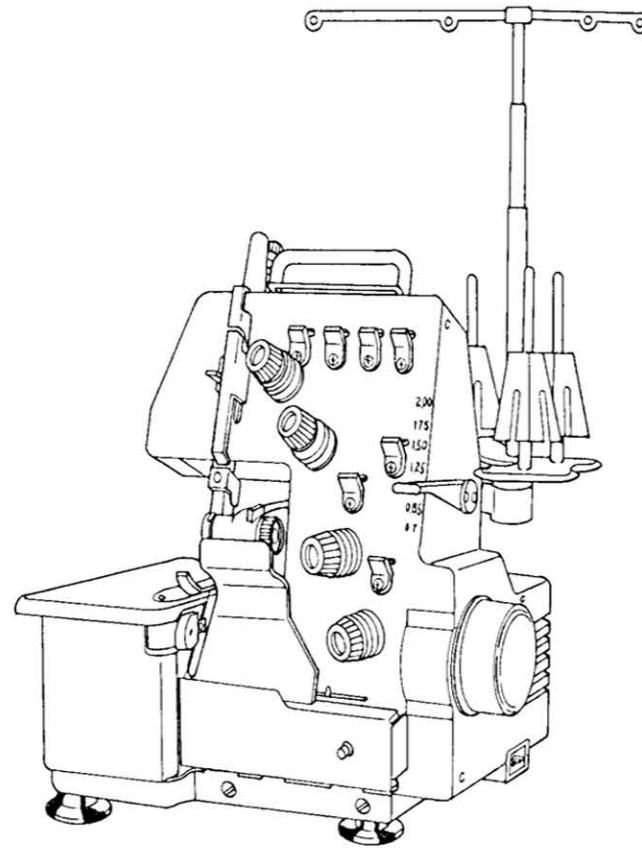

baby lock

1. Base plate, Handle, and Oil wick

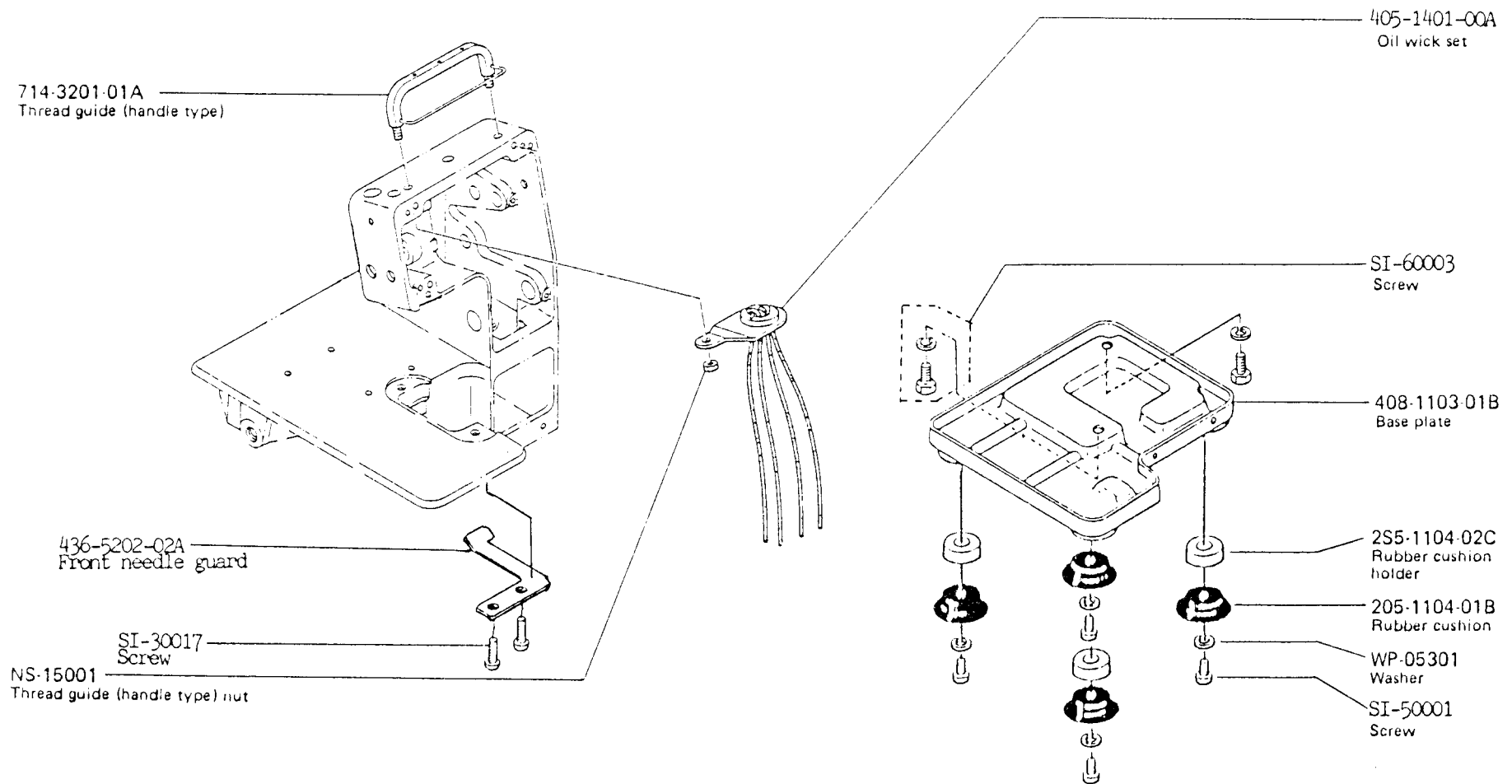

2. Covers

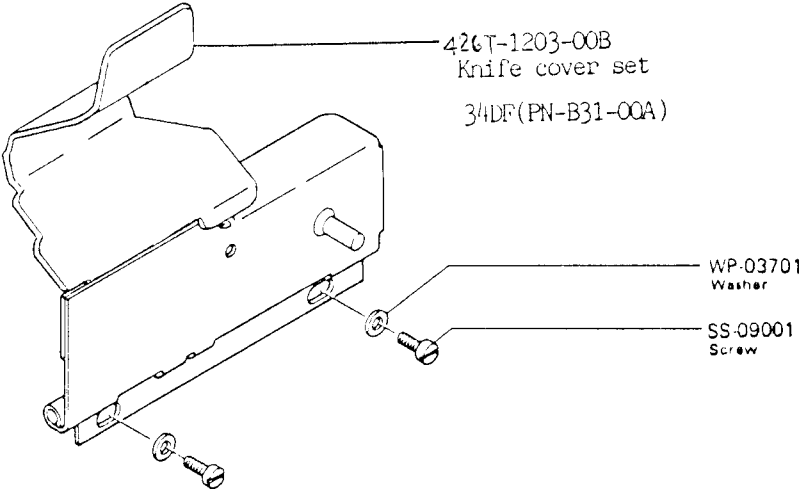
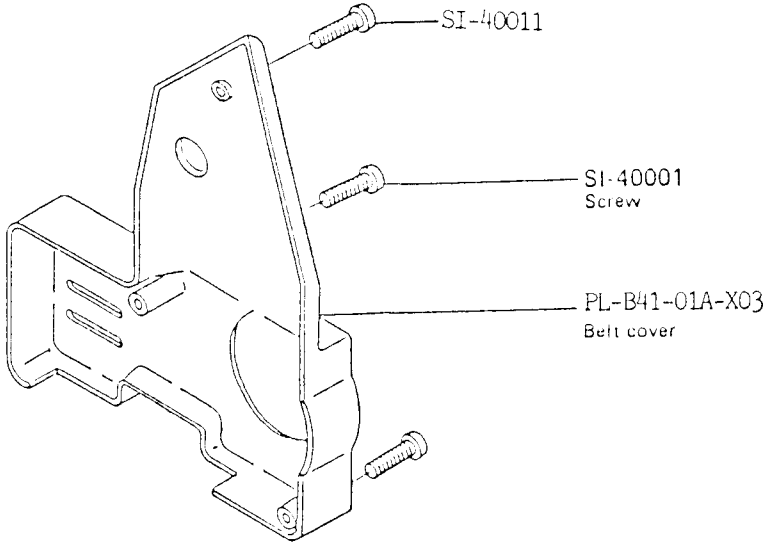
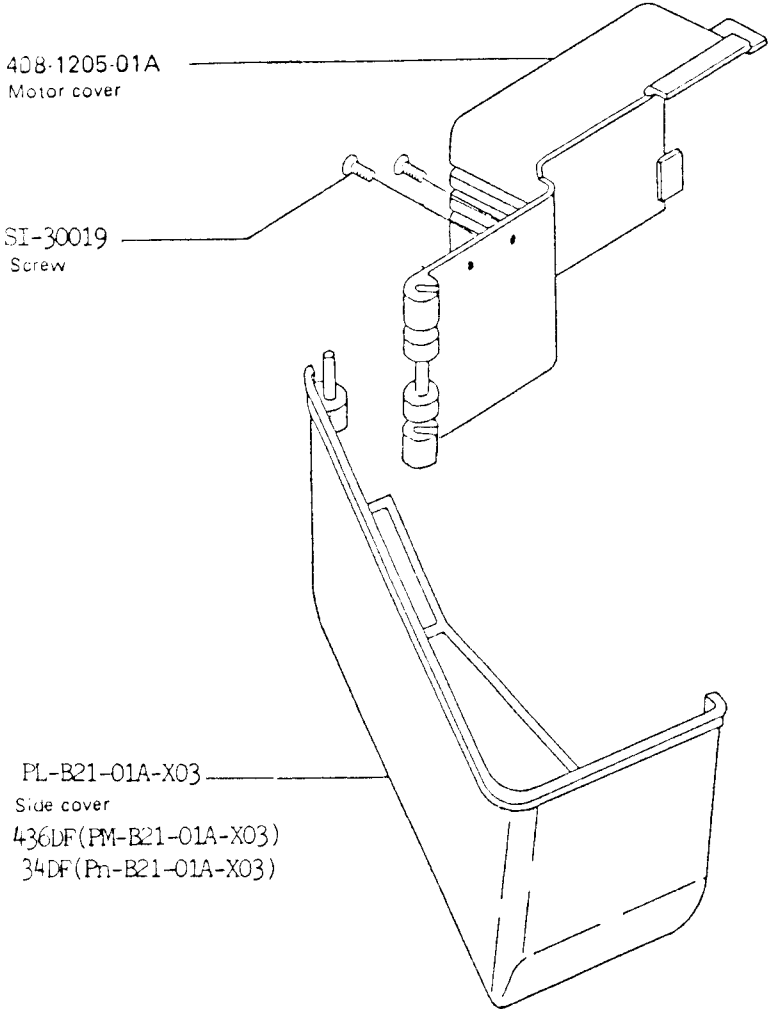

3. Machine pulley

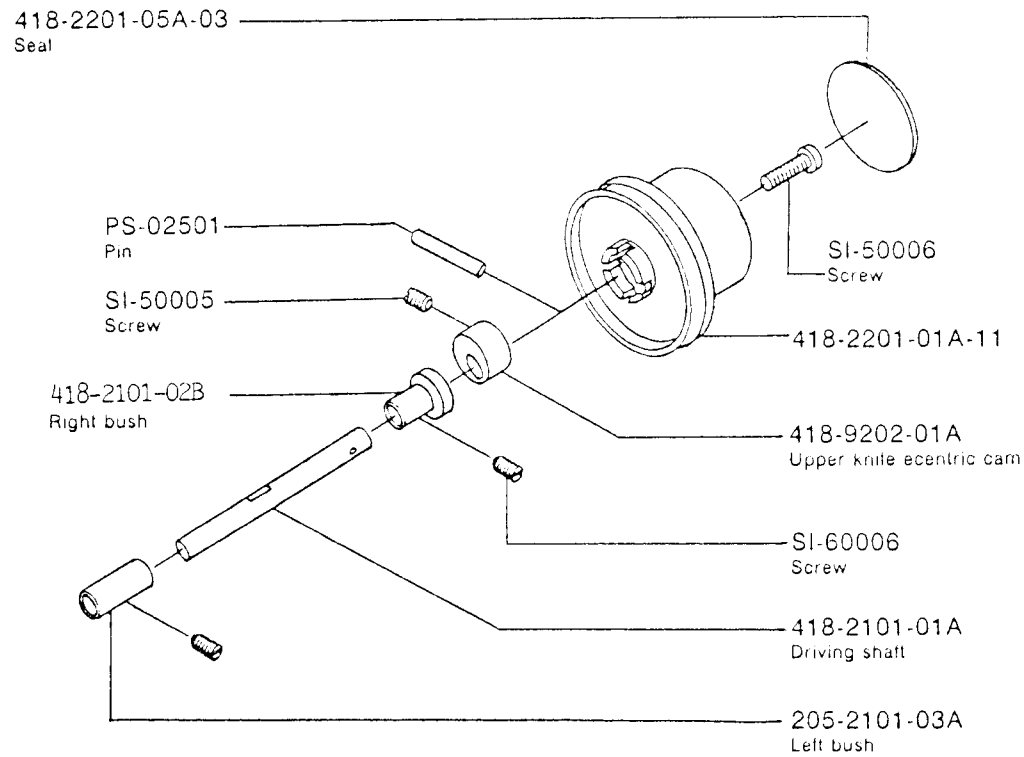

4. Spool stand components

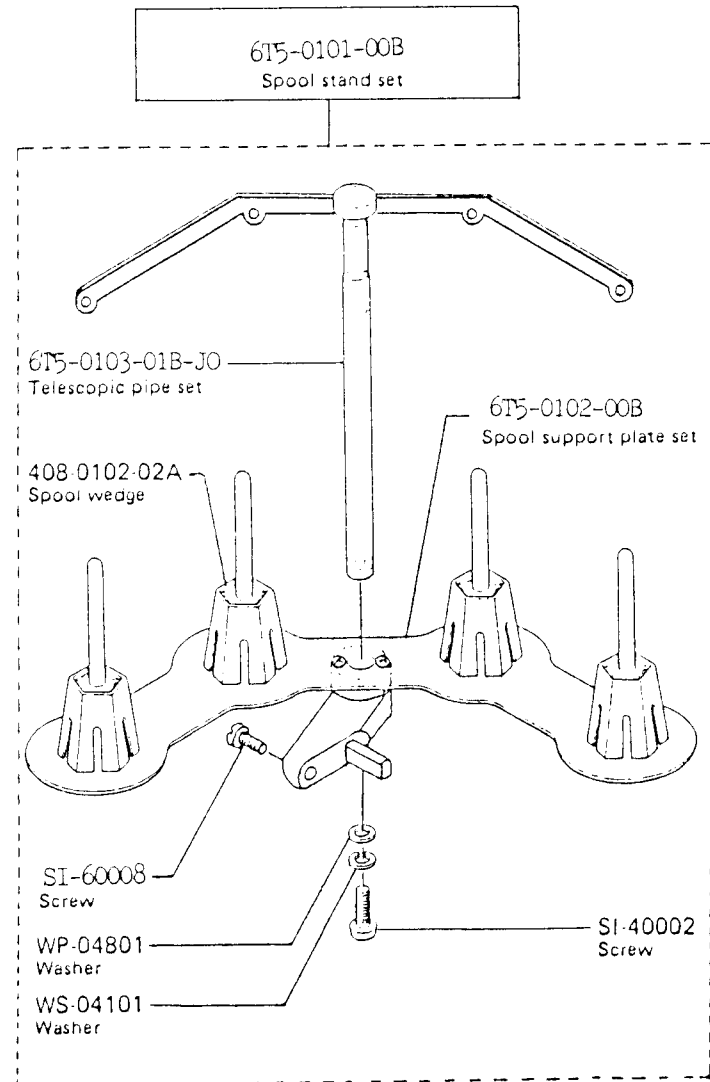

5. Face plate and Tension adjuster

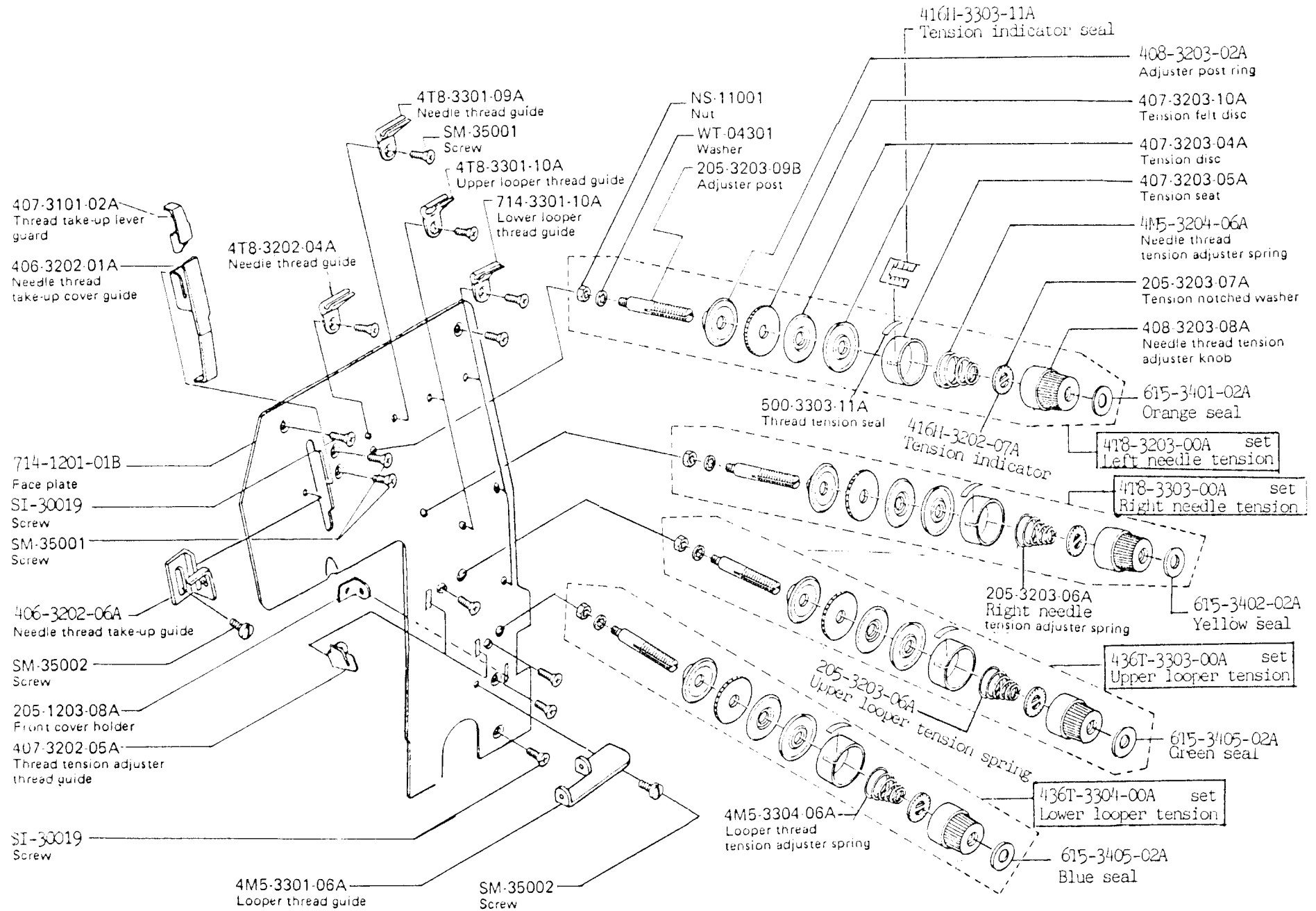

6. Needle bar components

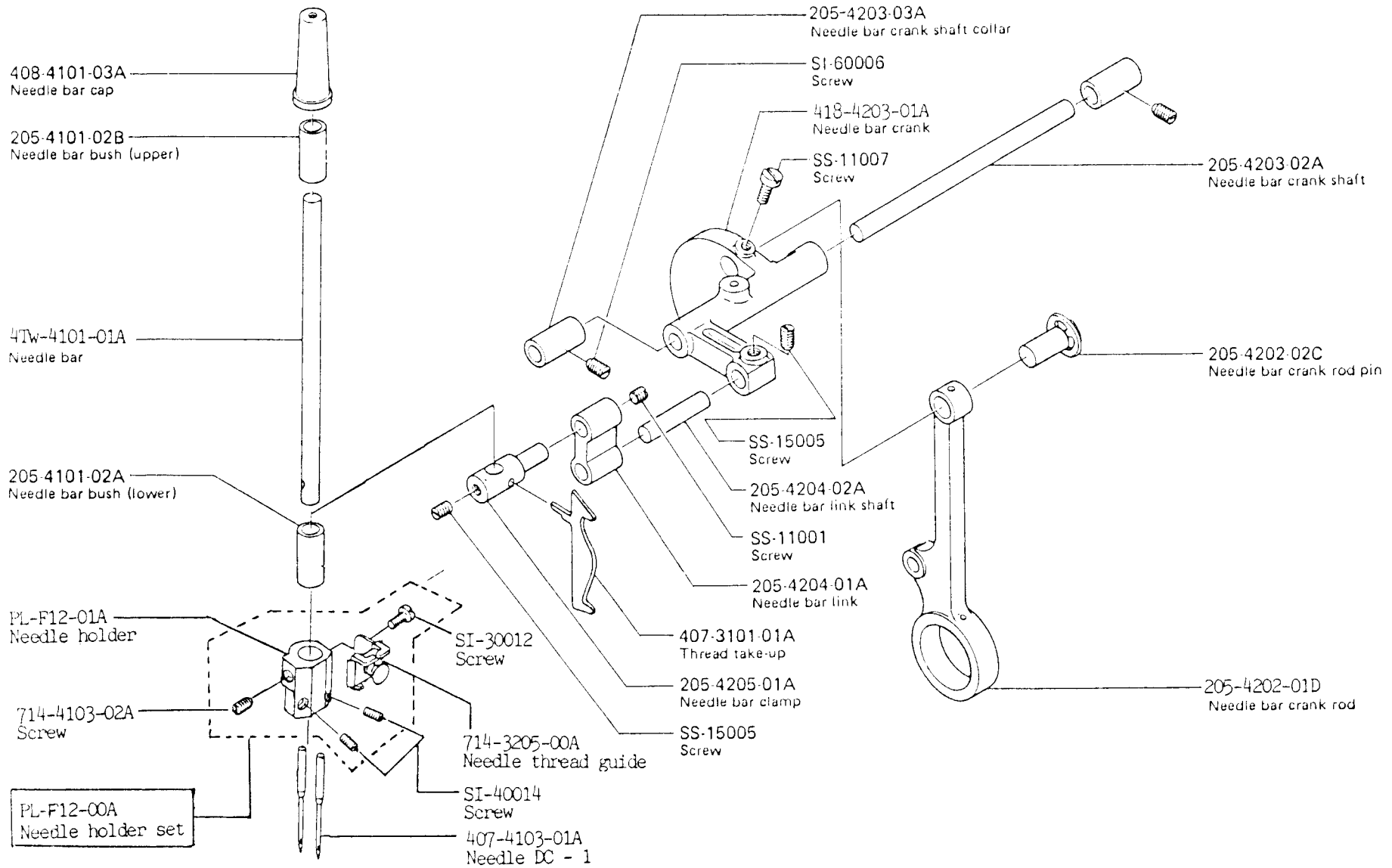

7. Upper looper components

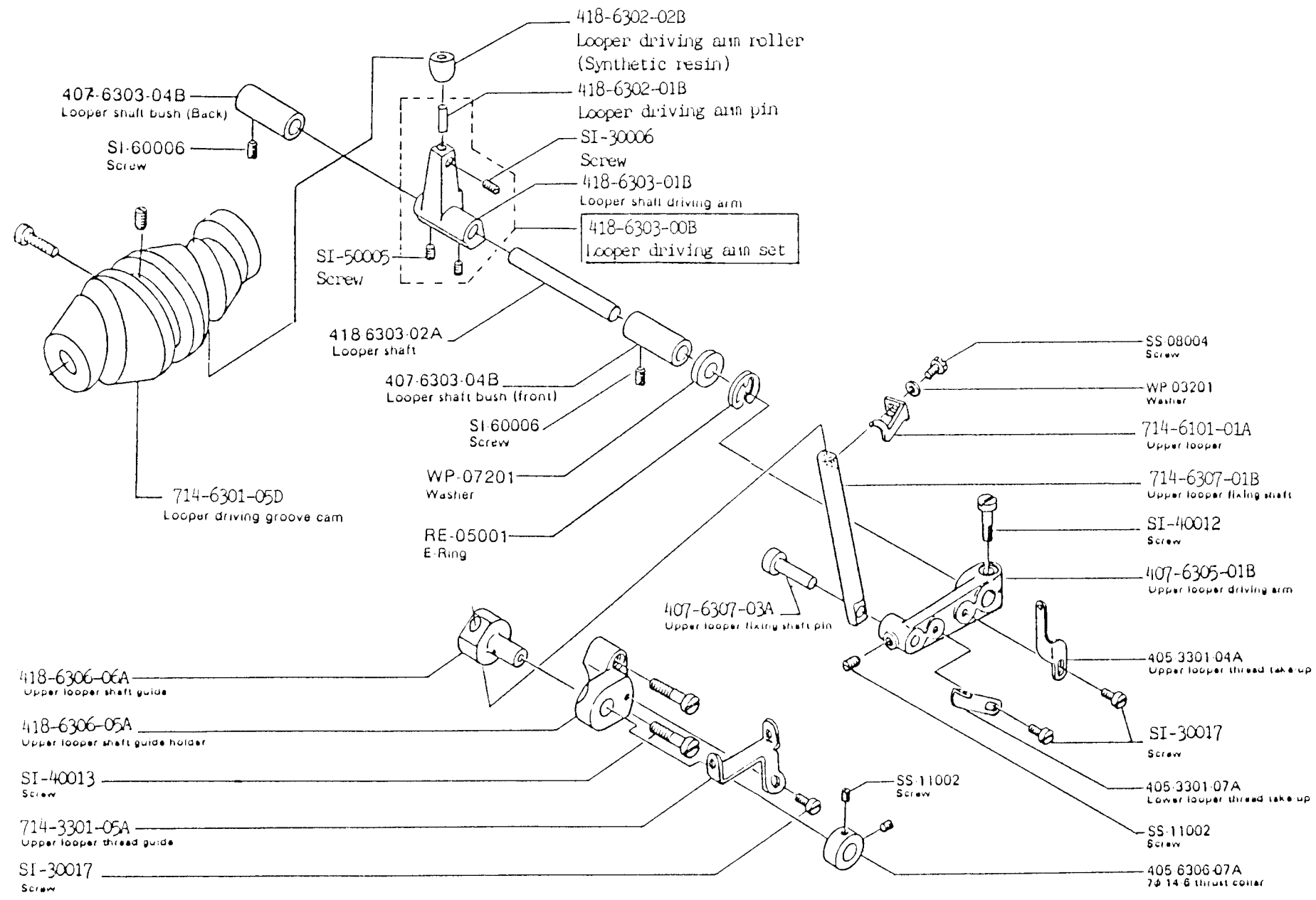

8. Lower looper components

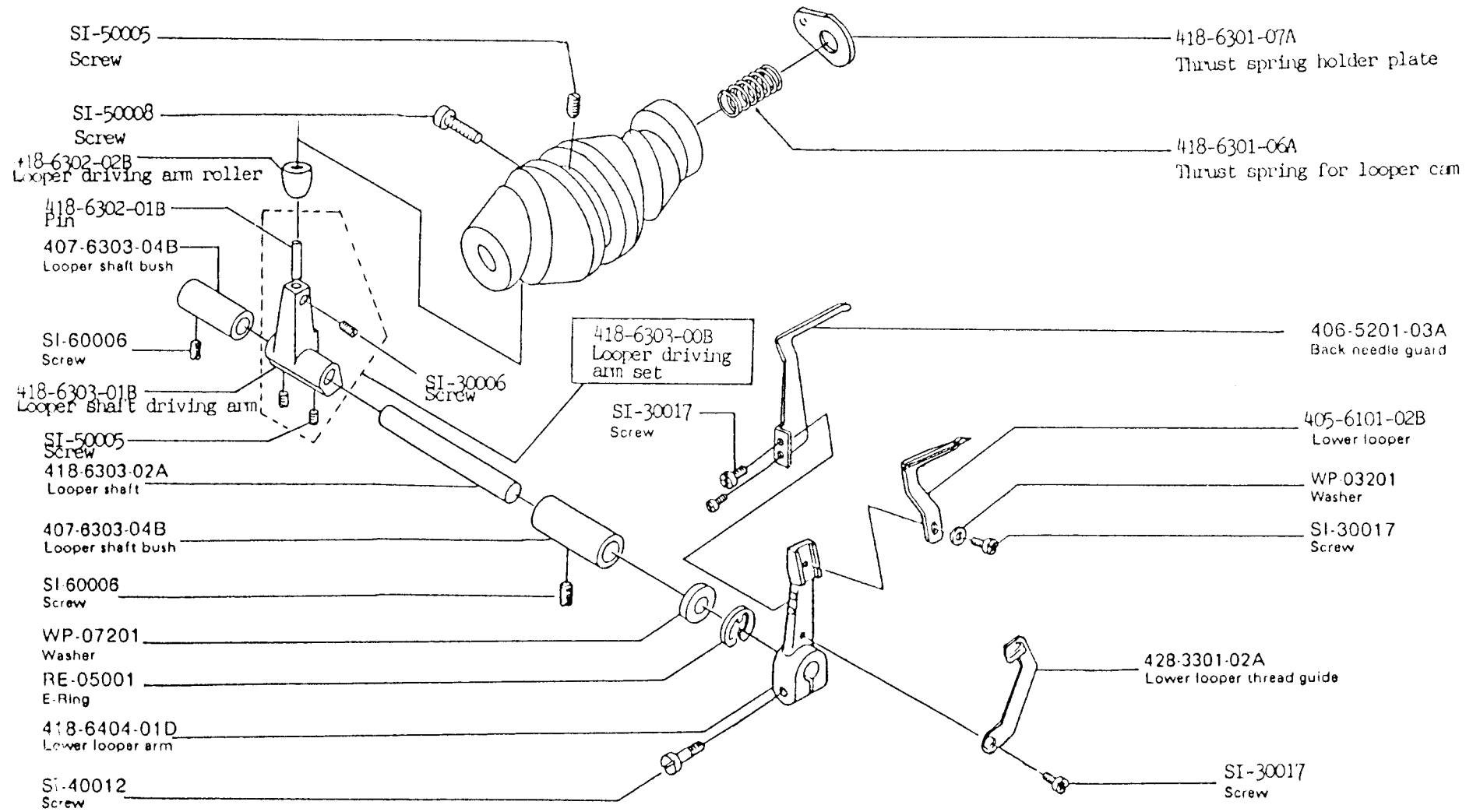

9. Differential Feed mechanism components

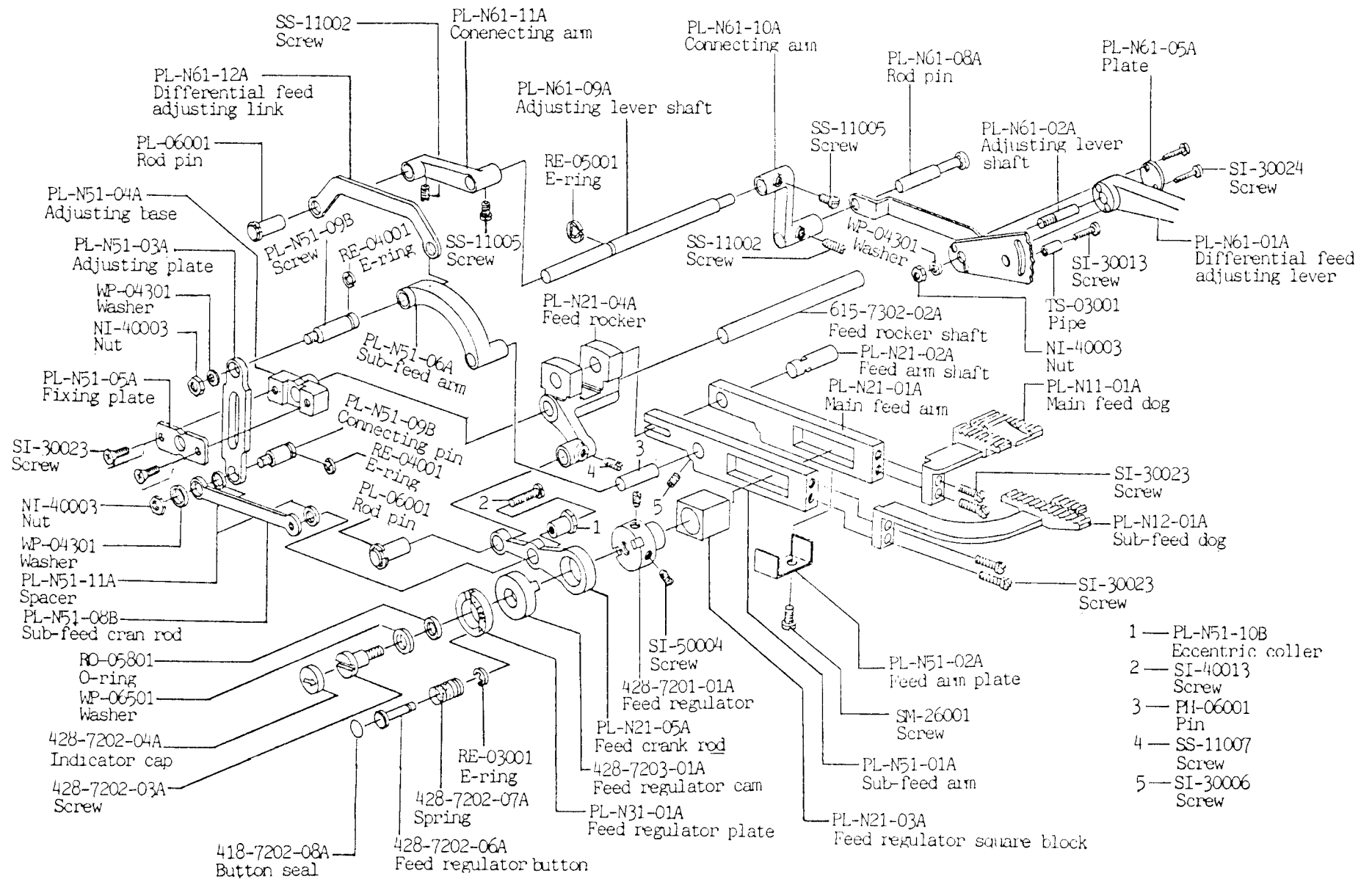

10. Presser foot components and Needle plate

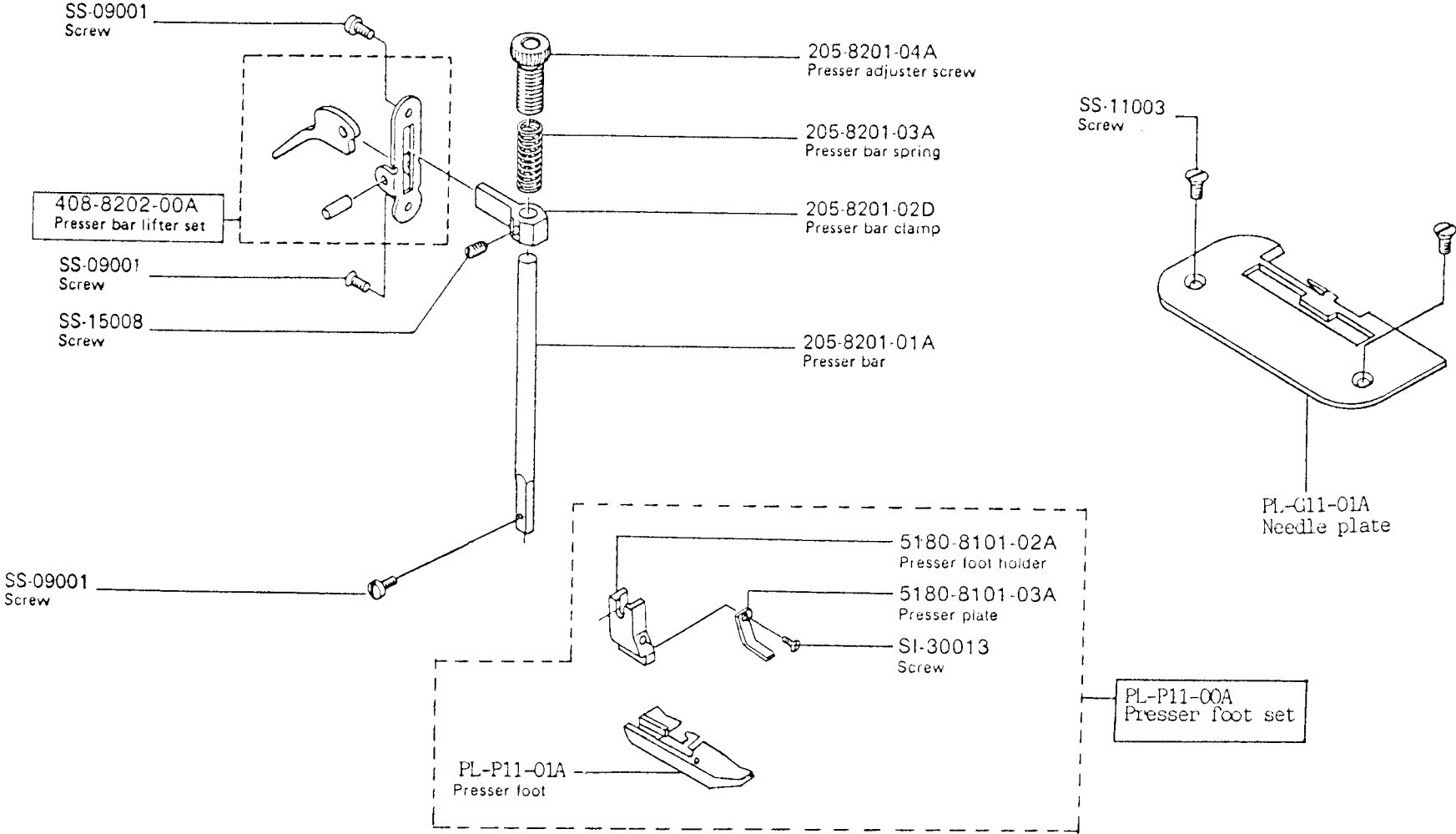

11. Knife components

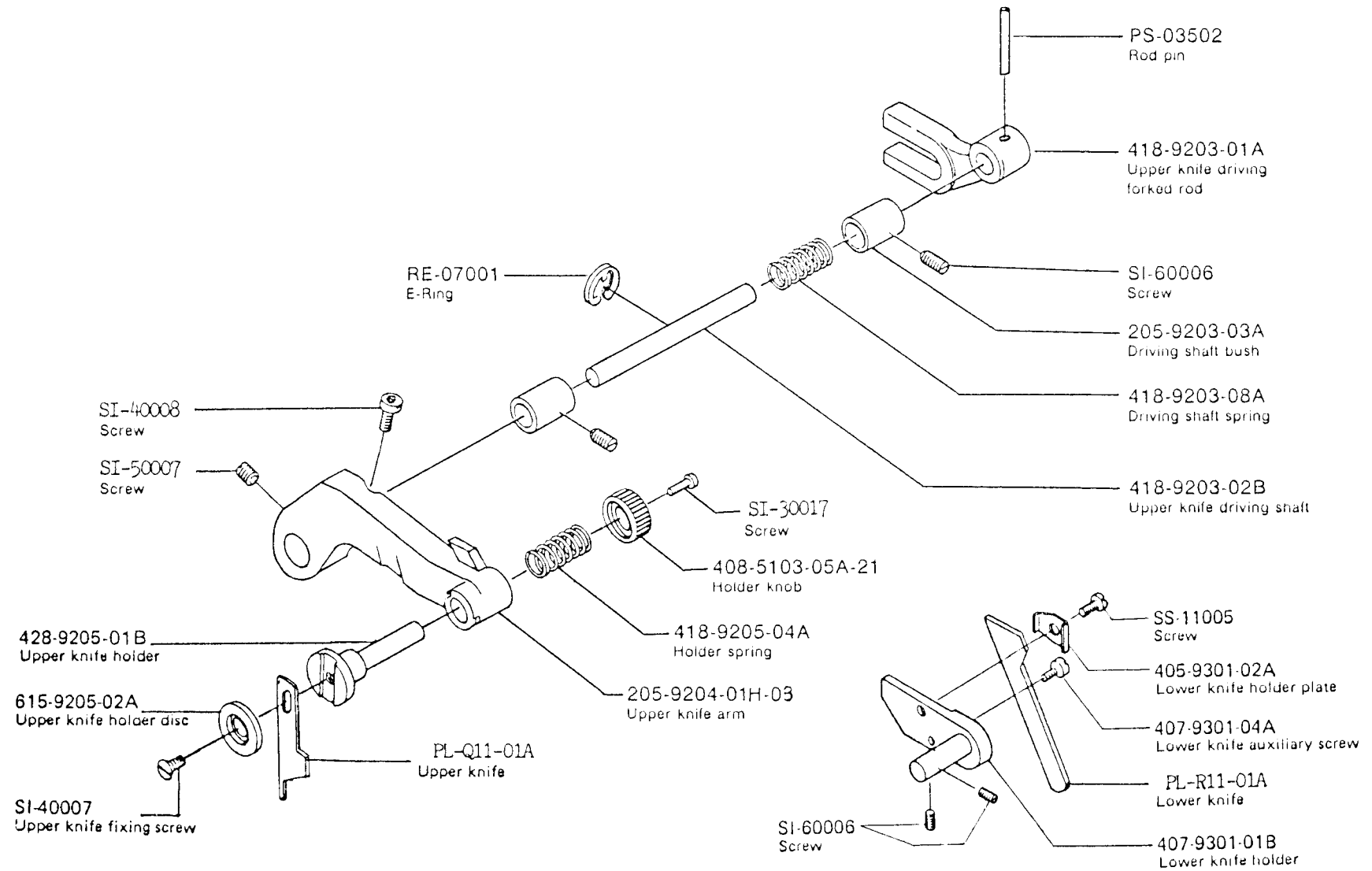

13. Motor and controller components

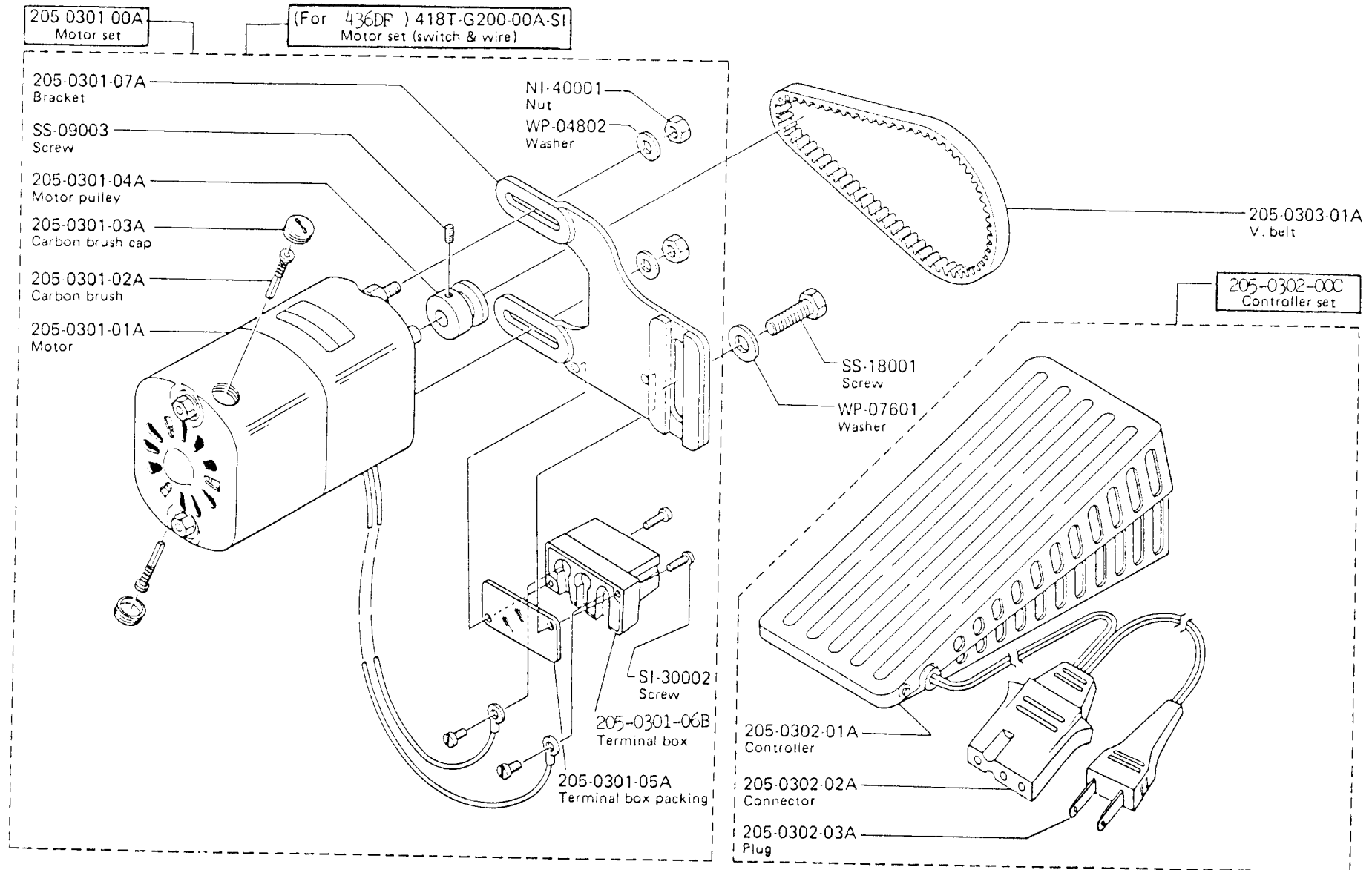

14. Standard accessories

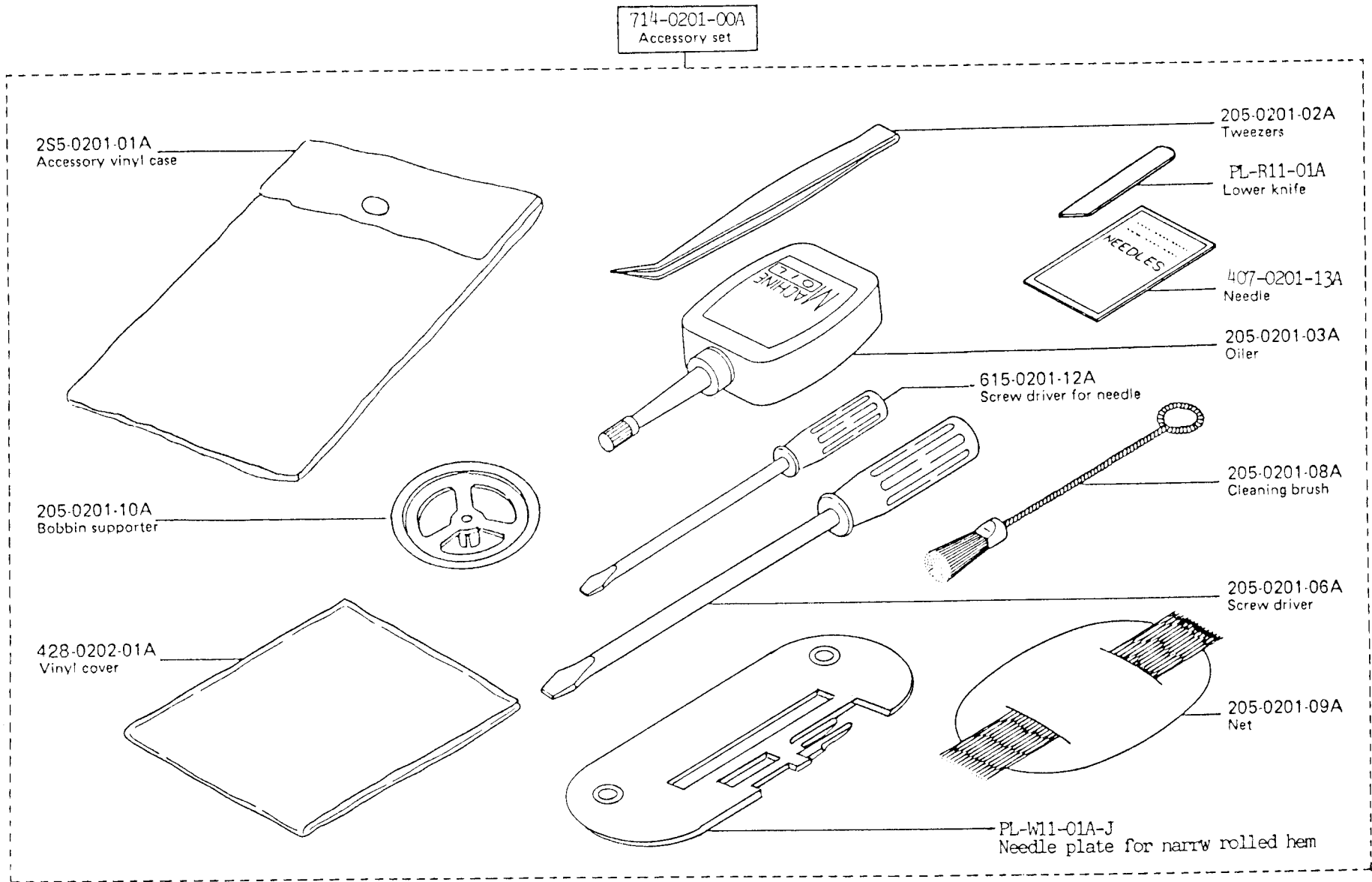

Rimoldi SpA - 33, Via Montebello - 20020 Olcella - Milano (Italy)
Tel. (0331) 563.111 - Telex 332299 - 312243 - Telefax (0331) 563.485 - 563.564

PRINTED IN ITALY BY FEOPRINT - MILANO

La Rimoldi SpA si riserva il diritto di modificare o variare, per motivi di ordine tecnico o commerciale, i dati riportati nella presente pubblicazione.

Rimoldi SpA reserves the right to modify or vary, for technical or commercial reasons, the information printed in this brochure.

SOLO I PEZZI DI RICAMBIO ORIGINALI RIMOLDI MARCATI **Rim** GARANTISCONO EFFETTIVA INTERCAMBIABILITA' FUNZIONALITA', DURATA.

RIMOLDI ORIGINAL SPARE PARTS MARKED **Rim** ARE THE ONLY ONES WHICH GUARANTEE INTERCHANGEABILITY, FUNCTIONALITY, AND LONG MACHINE LIFE

EXCLUSIVEMENT LES PIECES DE RECHANGE ORIGINALES RIMOLDI MARQUEES **Rim** GARANTISSENT UNE INTERCHANGEABILITE, UN CARACTERE FONCTIONNEL, UNE DUREE EFFECTIFS.

NUR DIE MIT **Rim** MARKIERTEN RIMOLDI-ORIGINALERSATZTEILE GARANTIEREN EINE EFFEKTIVE AUSTAUSCHBARKEIT, ZWECKENTSPRECHENDHEIT, LEBENSDAUER.

SOLO EL EMPLEO EXCLUSIVO DE REPUESTOS RIMOLDI MARCADOS **Rim** ASEGURAN LA CALIDAD DE INTERCAMBIABILIDAD, LA FUNCIONALIDAD Y LA DURACION.

La Rimoldi S.r.l. si riserva il diritto di modificare o variare, per motivi di ordine tecnico o commerciale, i dati riportati nella presente pubblicazione.

Rimoldi S.r.l. reserves the right to modify or vary, for technical or commercial reasons, the information printed in this brochure.

Rimoldi S.r.l. se réserve le droit de modifier ou changer les données établies sur la présente publication pour tous motifs d'ordre technique ou commercial.

Rimoldi S.r.l. kann jederzeit aus technischen oder kommerziellen Gründen Änderungen an den in diesem Heft beschriebenen Erzeugnissen vornehmen.

Rimoldi S.r.l. se reserva el derecho de modificar o variar, por motivos técnicos o comerciales, los datos aquí publicados.

DIRITTI RISERVATI: Nessuna riproduzione è permessa senza previa autorizzazione scritta della Rimoldi S.r.l.

ALL RIGHTS RESERVED: Reproduction in whole or in part is forbidden unless expressly authorized in writing by Rimoldi S.r.l.

DROIT RESERVES: Toute reproduction est interdite sans autorisation préalable écrite de Rimoldi S.r.l.

DERECHOS RESERVADOS: Se prohíbe la reproducción total o parcial sin previa autorización escrita de Rimoldi S.r.l.

VORBEHALTENE RECHTE: Keinerlei Widergabe ist ohne vorausgehender schriftlicher Genehmigung seitens der Rimoldi S.r.l. gestattet.