

Omnitex

CATALOGO PEZZI DI RICAMBIO
SPARE PARTS CATALOGUE
CATALOGUE RECHANGES

C09-00-2MD-06
C09-00-2MD-01

Il presente Catalogo Pezzi di Ricambio è costituito da due parti: la prima, definita come "Catalogo base", comprende i particolari montati sulla testa più significativa (la prima dell'elenco in copertina); la seconda comprende tutti i particolari delle altre teste basi o derivate, che differiscono da quella del Catalogo base.

Le Teste basi sono elencate in copertina con un carattere più grande rispetto a quello delle derivate.

Nella consultazione del Catalogo tenere presente che:

1. Tutti i particolari non fornibili sciolti non vengono richiamati singolarmente, ma soltanto illustrati nel gruppo d'appartenenza.
2. I riferimenti delle figure dei particolari che compongono il gruppo sono di norma raggruppati in una parentesi. In alcuni casi però, dove non è possibile il raggruppamento, i numeri che nelle tavole illustrative richiamano i singoli pezzi sono affiancati dallo stesso segno particolare, con cui è indicato l'intero gruppo.
3. Sulle tavole relative alle altre teste sono elencati tutti i particolari diversi o non montati sulla testa del Catalogo Base. Dette tavole portano in alto a destra il simbolo della testa cui si riferiscono (con indicato fra parentesi - nel caso di derivata - il simbolo della testa da cui deriva).
I disegni di questo gruppo di tavole illustrano soltanto i pezzi nuovi o sostanzialmente diversi rispetto a quelli montati sulla testa più significativa del Catalogo.
I particolari richiamati come simbolo, ma non illustrati, conservano lo stesso numero di figura dei corrispondenti raffigurati sul Catalogo base.
I particolari comuni a tutte le teste comprese nel Catalogo, vengono richiamati soltanto nel primo gruppo di tavole.
I particolari definiti come "pezzi annullati" si intendono quelli non montati sulla testa a cui la tavola si riferisce. Nel caso di un gruppo annullato, viene indicato soltanto il simbolo del gruppo, ma devono intendersi annullati anche tutti i particolari componenti il gruppo stesso.
Per ogni testa viene sempre riportata interamente la tavola relativa agli organi di cucitura.

Per facilitare la ricerca viene riportato l'indice numerico di tutti i particolari illustrati sul Catalogo base, con la relativa tavola in cui gli stessi sono richiamati.

AGHI

Gli aghi sono contraddistinti dal sistema e dalla finezza, la quale indica il diametro medio espresso in centesimi di millimetro.

Il sistema dell'ago e la finezza sono marcati oltre che sulla busta, anche sull'ago stesso.

Nelle ordinazioni precisare, oltre il simbolo, il sistema e la finezza degli aghi desiderati. In caso di dubbio, allegare, un ago campione o una bustina vuota.

AVVERTENZA

Nella richiesta di parti di ricambio citare sempre il relativo numero di matricola della macchina, il simbolo del particolare e la denominazione ufficiale usata sul catalogo.

This spare parts catalogue is made up of two parts: in the first one, called "basic catalogue", all the details of most representative head are listed (the first head listed on the cover); the second one includes the details of the other main heads or derived ones, which are different from that of the basic catalogue.

The main heads are listed on the cover in bigger lettering to distinguish them from the derived heads.

When you consult the catalogue will you please note that:

1. all parts which cannot be supplied by themselves are not indicated alone, but shown together with the group to which they belong;
2. the references of the pictures of the parts making up the group are usually put in brackets.
In some cases, however, when their grouping is not possible, the numbers of the various parts in the tables are marked with the same particular sign with which the whole group is indicated.

3. In the tables of the other heads there are listed all the parts not fitted on the head in the basic catalogue.

These tables are marked at the top right-hand corner with the symbol of the head which the table refers to.

The drawings in this group of tables show only the parts which are new or basically different from those fitted on the most representative head in the catalogue.

The parts which are represented only by the symbol but not illustrated keep the same figure number as the corresponding parts shown in the basic catalogue.

The parts which are common to all the heads in the catalogue are listed only in the first group of tables.

Parts marked "annulled part" are those not fitted on the head which the table refers to.

When an assembly has been annulled only the assembly symbol is specified, but all the parts forming the assembly must also be considered annulled.

For each head the table for sewing parts is always repeated completely

To make it easier to locate the parts, the reference numbers of all of those shown in the basic catalogue are listed together with the number of the table in which they are to be found.

NEEDLES

The needles are marked with system and size; the size indicates the average diameter in hundredths of a millimeter.

The system and size of the needle are shown on the packet as well as on the needle itself.

When ordering please state symbol, system and size. If you have doubts, enclose a sample needle or an empty packet with your order.

ATTENTION

When ordering spare parts always state the serial number of the machine, the symbol of the part in question and the description given in the catalogue.

Ce catalogue "pièces détachées" est formé de deux parties: la première appelée "catalogue base" comprend toutes les pièces montées sur la tête la plus significative (celle en tête de la liste de couverture), la seconde comprend toutes les pièces montées sur les autres têtes de base ou dérivées qui sont différentes de celle du "catalogue base".

Les têtes de base sont énumérées sur la couverture, en caractères plus grands que les têtes dérivées.

Lorsque l'on consulte le catalogue, se souvenir que:

1. Toutes les pièces qui ne sont pas fournies séparément mais qui font partie d'un groupe, ne sont pas indiquées séparément.
2. Les symboles des pièces qui forment un groupe sont regroupés entre parenthèses. Cependant, lorsque ceci n'a pas été possible, les symboles, qui dans les tables d'illustration correspondent aux pièces, sont suivis du même signe particulier qui indique le groupe tout entier.

3. Dans les tables relatives aux autres têtes, nous avons indiqué toutes les pièces différentes de celles de tête du "catalogue base" ou qui ne sont pas montées sur ces dernières. Ces tables portent, en haut à droite, le symbole des têtes auxquelles elles se réfèrent (pour les dérivées, le symbole de la tête de laquelle elles dérivent est indiqué entre parenthèses).

Les dessins de ce groupe de tables représentent seulement les nouvelles pièces ou celles qui sont différentes des pièces montées sur la tête la plus significative du catalogue.

Les pièces indiquées par un symbole, mais qui ne sont pas illustrées, gardent le même numéro de dessin que celles correspondantes, illustrées sur le catalogue base.

Les pièces communes à toutes les têtes du catalogue, sont indiquées seulement dans le premier groupe de tables.

Les pièces définies comme "pièces annulées" sont celles qui ne sont pas montées sur la tête à laquelle se réfère la table. Dans le cas de l'annulation d'un groupe, nous indiquons seulement le symbole du groupe, mais toutes les pièces qui forment ce groupe sont annulées.

Pour chaque tête est toujours indiquée la table se référant aux organes de couture.

Pour faciliter la recherche, le catalogue renferme l'index numérique de toutes les pièces illustrées avec indication de la table dans laquelle elles sont indiquées.

AIGUILLES

Les aiguilles se différencient par le système et la grosseur, laquelle indique le diamètre moyen exprimé en centièmes de millimètre.

Le système de l'aiguille et sa grosseur, sont indiqués non seulement sur le sachet mais également sur l'aiguille.

Dans la commande, préciser, en plus du symbole, le système et la grosseur des aiguilles désirées. En cas de doute, joindre une aiguille comme modèle ou un sachet vide.

ATTENTION

Dans la commande de pièces détachées, indiquer toujours le numéro de la machine, le symbole de la pièce et la dénomination officielle mentionnée sur le catalogue.

INDEX

SIMB.	TAV.	SIMB.	TAV.	SIMB.	TAV.	SIMB.	TAV.	SIMB.	TAV.	SIMB.	TAV.	SIMB.	TAV.
100620-2-10	6	202492-0-10	5	206455-4-01	7	206618-0-10	6	206764-0-00	3	207684-3-01	16	207927-0-01	9
200324-0-10	4	202529-0-10	10	206507-0-00	5	206619-0-00	6	206767-0-00	3	207685-3-01	8	207930-0-10	9
200490-0-00	6	202556-0-10	4	206508-0-00	5	206620-0-00	10	206768-0-00	3	207687-0-00	8	207932-0-10	9
201128-0-10	7	202558-2-00	4	206512-0-62	13-16	206621-0-00	10	206769-0-10	3	207688-2-00	8	207934-4-00	1
201358-0-10	6	202609-0-60	13	206521-0-00	9	206622-0-00	10	206790-2-11	6	207690-0-00	8	207942-3-00	6
201610-0-01	6	202681-0-10	4	206533-0-00	9	206625-0-01	10	206796-0-00	6	207691-0-00	8	207943-2-00	1
202026-0-10	2	202720-0-00	7	206538-0-10	1	206635-0-00	10	206797-0-00	3	207692-2-00	8-9	207944-0-00	6
202027-0-10	2	203135-2-10	4	206539-0-01	1	206637-0-00	10	206798-0-00	6	207693-2-00	8	207945-0-00	1
202032-0-11	6	203187-0-10	10	206542-2-10	9	206642-0-00	10	206808-0-01	16	207698-4-00	6	207946-0-00	6
202033-0-10	6	203457-0-10	4	206543-0-01	5	206645-4-02	7	206812-0-00	4	207700-0-00	8	207947-0-00	1
202062-2-10	7	203635-0-10	4	206544-0-00	5	206651-0-00	1	206860-0-01	5	207701-0-00	8	207948-0-00	1
202063-0-10	6	204122-0-10	5	206545-0-00	12	206653-2-01	7	206872-0-00	6	207702-0-00	8	207951-4-00	2
202065-0-20	1	204684-2-11	11	206546-0-00	6	206654-2-10	7	206876-0-01	4	207703-2-00	8	207952-2-00	2
202086-0-11	7	204687-0-11	11	206554-0-02	12	206659-2-02	7	206969-0-00	5	207704-0-00	8	207953-0-00	2
202128-0-10	11	204704-0-10	4	206555-0-01	12	206662-0-00	12	206982-0-01	16	207705-0-00	1	207954-0-01	2
202129-0-10	11	204747-0-10	4	206556-0-01	5	206665-2-00	12	206985-0-00	16	207706-0-00	1	207955-2-01	2
202130-0-11	11	204756-0-10	4	206557-0-00	12	206667-0-00	12	206994-2-01	5	207707-0-01	1	207958-0-00	2
202165-0-11	3	204757-0-11	5	206558-0-01	12	206679-0-00	5	207003-2-60	13-16	207708-0-00	8	207959-0-00	10
202194-0-11	10	204798-0-30	1	206559-0-01	12	206682-0-01	1	207020-2-61	13	207711-2-10	6	207960-0-00	10
202214-0-11	3-10	204861-0-60	13-16	206560-0-20	12	206683-0-00	5	207095-2-00	7	207719-0-01	6	207961-0-00	3
202225-0-11	4	204863-0-61	13-16	206564-0-00	12	206684-0-10	5	207096-2-00	7	207721-2-02	8	207962-0-00	10
202227-0-10	4	204869-0-11	13	206565-0-01	12	206685-0-00	3	207133-3-63	16	207722-0-61	13-16	207965-0-00	10
202228-0-10	4	204878-0-11	13	206566-0-00	12	206686-0-00	7	207219-0-10	4	207724-2-00	6	207967-0-01	10
202229-0-10	4	204889-0-10	13	206567-0-01	12	206687-2-00	3	207221-2-10	4	207725-0-60	16	207968-0-01	4
202257-0-10	4	204894-0-11	13	206568-0-01	12	206688-0-00	3	207224-0-10	4	207728-2-00	3	207970-2-01	12
202258-0-10	4	204895-0-11	13	206569-0-01	12	206689-0-01	5	207225-0-10	4	207730-2-02	7	207971-0-00	12
202260-0-10	4	204905-0-10	13-16	206574-2-01	11	206690-2-00	5	207417-0-01	11	207758-0-01	1	207972-4-01	12
202279-0-00	4	204947-0-10	13-16	206580-2-00	6	206692-0-00	5	207526-2-00	9	207856-0-00	3	207973-0-01	12
202281-0-10	4	205007-0-62	13	206583-0-00	6	206693-0-00	5	207543-0-00	9	207858-0-00	3	207975-0-00	12
202371-0-10	1	205011-0-60	13	206584-2-00	6	206695-0-00	7	207552-4-00	4	207861-4-00	11	207977-0-00	12
202385-0-10	6	205021-0-10	10	206586-0-01	6	206697-4-01	5	207554-0-00	16	207873-0-00	4	207978-0-00	12
202386-0-10	5	205024-0-62	11	206587-0-01	6	206699-0-01	5	207562-0-00	4	207876-2-00	10	207979-0-00	12
202391-0-11	10	205025-0-62	13	206588-0-00	6	206708-0-00	5	207581-0-61	16	207878-3-00	10	207980-0-00	2
202398-0-10	2	205042-0-11	10	206592-3-00	6	206711-0-00	4	207584-0-00	16	207879-0-00	1	207981-0-00	2
202408-0-10	6	205052-2-13	4	206593-0-00	6	206713-2-00	4	207585-0-00	16	207880-0-00	1	207983-0-00	2
202412-0-11	6	205070-3-62	13	206594-0-00	1	206733-0-01	3	207625-0-00	10	207881-2-00	10	207984-0-00	2
202413-0-62	13-16	206090-0-10	4	206595-0-01	1	206734-2-00	3	207626-0-00	10	207882-2-00	10	207985-0-00	2
202473-0-11	6	206091-4-02	4	206598-3-00	6	206740-0-00	1	207641-0-60	16	207886-4-00	10	207988-0-00	2
202475-0-01	6	206093-3-00	16	206599-0-10	6	206747-0-01	4	207642-0-60	16	207887-4-00	16	208015-0-00	7
202478-0-10	6	206296-0-00	1	206603-0-11	6-9	206748-0-00	1	207646-0-60	16	207893-0-00	4	208028-2-00	3
202480-0-10	2	206340-4-00	4	206605-0-01	6	206754-0-00	4	207650-0-01	11	207901-0-01	12	208039-4-00	7
202484-0-10	3	206341-4-00	4	206606-0-00	9	206755-0-00	4	207651-0-60	16	207909-0-00	12	208073-4-00	3
202488-0-10	6	206342-4-00	4	206613-0-00	6	206756-0-01	3	207653-0-01	11	207910-0-00	4	208087-3-00	12
202489-0-10	6	206343-4-00	4	206615-4-00	6	206757-0-00	11	207668-0-00	4	207917-0-00	1-12	208090-0-01	4
202490-0-10	6	206453-4-00	7	206617-0-01	6	206758-0-00	11	207669-0-00	4	207919-0-00	4	208091-0-01	4

INDEX

SIMB.	TAV.	SIMB.	TAV.	SIMB.	TAV.	SIMB.	TAV.	SIMB.	TAV.	SIMB.	TAV.	SIMB.	TAV.
208133-2-00	10	701116-0-00	5	721883-0-00	7	741675-0-00	4	778511-0-00	9				
208163-4-11	9	701133-0-00	5	722063-2-00	1-3-5-10-12	741745-2-00	6	778522-0-00	10				
208164-0-00	1	701151-0-00	12	722089-2-00	7-8	741956-2-00	4-5	778832-0-00	1				
208165-0-00	2	702415-0-00	2	722119-2-00	8	742086-2-00	1	778833-0-00	1				
208169-0-00	4	703405-0-00	3	722123-2-00	10	742232-2-00	8	778835-0-00	11				
208172-4-00	4	704004-0-00	4	722443-2-00	8	742457-2-00	11	778837-0-00	9				
208184-2-00	4	704205-2-00	8	722471-2-00	11	742758-0-00	11	780501-0-00	13-16				
208220-0-00	4	704213-2-00	5	722511-2-00	12	742838-2-00	1	788006-0-01	4				
208221-0-00	4	704218-2-00	4	722905-2-00	15	743469-2-00	5	900201-0-10	15				
208222-0-00	4	704314-2-00	6-8	724032-0-00	6	744332-2-00	6-10	900203-0-10	15				
208224-0-00	4	704345-2-00	12-15	724422-2-00	4	744334-2-00	6-9-11	900204-0-10	15				
208255-0-00	4	704346-2-00	15	724460-0-00	9	744512-4-00	1	900694-0-11	15				
208256-4-00	4	704406-0-00	11	724895-2-00	3	744573-0-00	11	901101-0-00	15				
208520-2-10	5	704409-2-00	6-11	727014-2-00	9	744631-2-00	4	901102-0-00	15				
208521-2-00	5	704424-2-00	15	727021-5-00	9	744730-2-00	3	926273-0-00	10				
209270-2-01	7	704428-2-00	2	727096-0-00	10	744742-2-00	2	930845-0-00	4				
209272-0-00	7	704630-0-00	4	727203-0-00	5	745002-0-00	4-7-8-9	990176-0-10	14				
209309-2-00	8	704808-0-00	6	727884-0-00	6	745114-0-00	9-10	990179-4-11	15				
209767-0-00	4	704813-0-00	12	729012-2-00	9	745168-0-00	7	990310-0-10	15				
211612-0-01	6	704825-0-00	8	729022-2-00	2-12	745800-2-00	3-4-7	990311-0-10	15				
300218-0-10	4	704829-0-00	6	729032-2-00	6-8	745810-2-00	7-9	990314-0-10	15				
300387-0-10	4	704841-0-00	6	729034-2-00	9	745812-2-00	6-7-8-9-10	990316-0-11	15				
301586-0-10	10-12	704847-0-00	7	729051-2-00	6-9-10	745815-2-00	6	990325-0-10	14				
301608-0-00	1	705008-0-00	6	729422-2-00	8	746007-2-00	3-10-12	990335-0-10	12				
304172-0-10	8	705013-0-00	4	730011-2-00	6	746008-0-00	6	990452-0-00	15				
304195-0-10	8	705030-0-00	9-11	730022-2-00	8	746020-2-00	10	990474-0-11	14				
304815-0-10	4	705208-0-00	6	730023-2-00	3	746208-2-00	3	990577-0-10	14				
307137-0-00	2	705230-0-00	6	733008-2-00	12-15	746402-2-00	15	990639-0-10	14				
308503-0-01	4	705408-0-00	6	733503-0-00	4	746409-2-00	15	990685-0-10	14				
309560-0-00	9	705970-0-00	12	733505-2-00	4-10	748086-2-00	12	990693-0-01	10				
310167-0-00	9	705975-0-00	2	733507-0-00	12	765510-6-10	9	990694-0-01	16				
311069-0-00	8	705977-0-00	12	740053-2-00	6	765515-6-12	16	990723-0-00	14				
700008-0-00	8	705982-0-00	2	740230-2-00	13-16	778202-0-00	7	990918-0-00	14				
700205-0-00	15	707602-0-00	4	741405-0-00	9	778204-0-00	9-10	990981-0-00	15				
700207-0-00	6-8	720411-2-00	12	741413-2-00	6-13-16	778208-0-00	9	990982-0-00	15				
700630-0-00	5	721412-2-00	2	741415-2-00	7-9	778236-0-00	7	990984-4-10	15				
701002-0-00	12	721424-2-00	4	741431-0-00	13-16	778241-0-00	2	990987-4-00	15				
701004-0-00	6-8-12	721431-0-00	13	741453-0-00	10	778401-0-00	6-7	991187-0-01	15				
701005-0-00	12	721434-2-00	10	741520-0-00	11	778403-0-00	7	991218-0-00	12				
701007-0-00	6-8	721435-2-00	3	741535-0-00	12	778405-0-00	7	991280-0-10	14				
701011-0-00	1	721443-2-00	2-3-13-16	741546-2-00	6	778410-0-00	7	991400-4-02	14				
701031-0-00	12	721454-2-00	2	741558-0-00	4-8	778414-0-00	9	991415-0-00	14				
701051-0-00	12	721475-2-00	6	741559-2-00	4	778417-0-00	1-6-9						
701106-0-00	12	721484-2-00	4-12	741620-2-00	8	778419-0-00	9						
701113-0-00	7	721494-2-00	12	741658-2-00	2	778503-0-00	9						

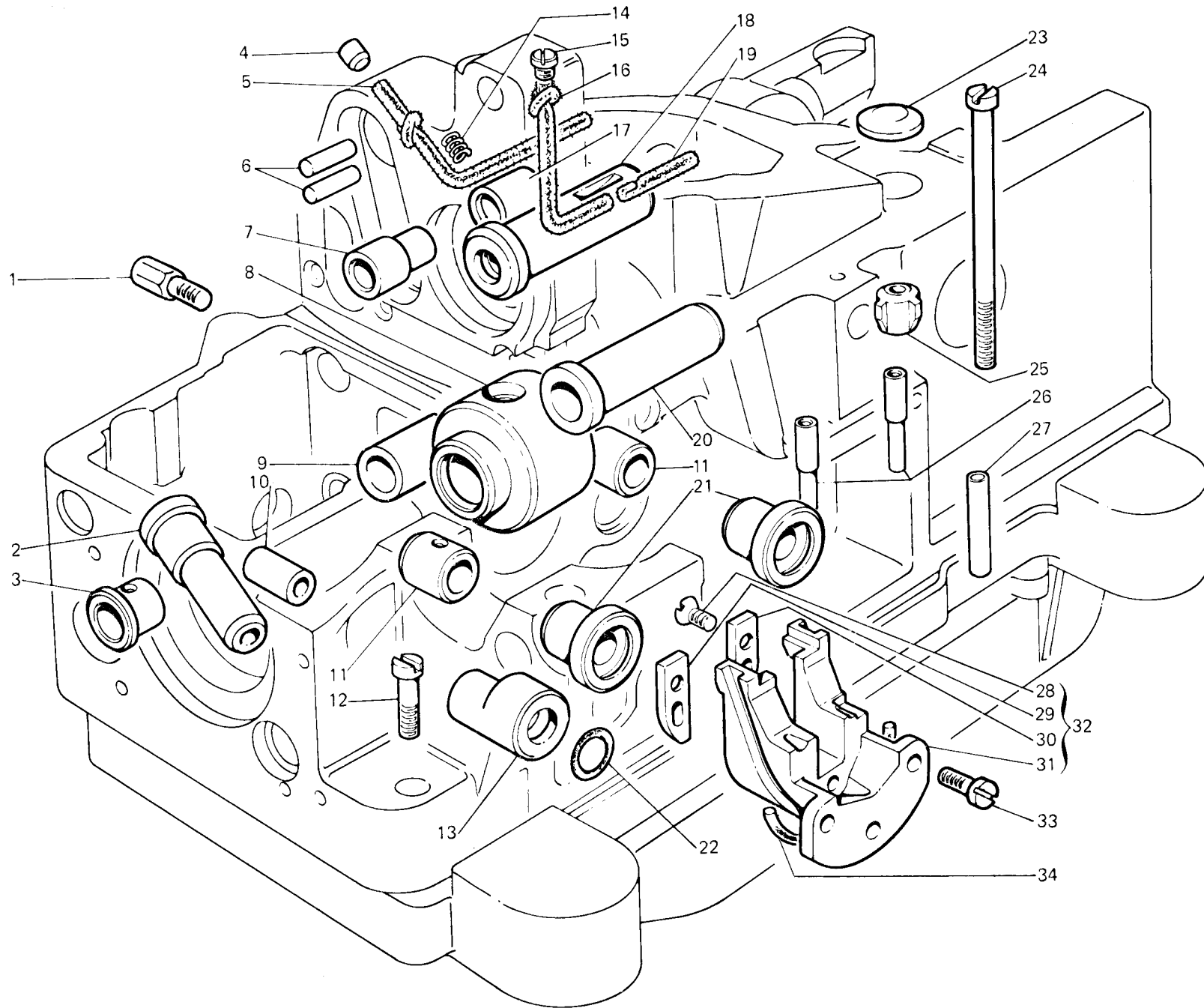

Fig. N. Abb. N.	Part. N. Piecce N. Bestell N. Pieza N.	Qt. Anzahl	DESCRIZIONE	DESCRIPTION	DESCRIPTION	BENENNUNG	DESCRIPCION
1	204798-0-30	1	vite	screw	vis		
2	207707-0-01	1	guida pulsante	guide	guide		
3	206595-0-01	1	bussola sinistra	left bush	bague gauche		
4	301608-0-00	1	tappo	plug	bouchon		
5	778832-0-00	1	stoppino	wick	mèche		
6	202371-0-10	2	spina	pin	goupille		
7	207880-0-00	1	bussola	bush	bague		
8	206682-0-01	1	bussola intermedia	intermediary bush	bague intermédiaire		
9	206594-0-00	1	bussola	bush	bague		
10	207705-0-00	1	bussola	bush	bague		
11	206651-0-00	2	bussola posteriore	rear bush	bague arrière		
12	742086-2-00	1	vite	screw	vis		
13	207706-0-00	1	bussola	bush	bague		
14	208164-0-00	1	molla	spring	ressort		
15	742838-2-00	1	vite	screw	vis		
16	778833-0-00	1	stoppino	wick	mèche		
17	207879-0-00	1	bussola	bush	bague		
18	206538-0-10	1	bussola	bush	bague		
19	778417-0-00	1	stoppino	wick	mèche		
20	206539-0-01	1	bussola	bush	bague		
21	202065-0-20	2	bussola anteriore	front bush	bague avant		
22	701011-0-00	1	anello di tenuta	retainer ring	bague d'étanchéité		
23	206748-0-00	1	tappo espansione	plug	bouchon		
24	207917-0-00	4	vite	screw	vis		
25	207758-0-01	1	bussola guida astina	bush	bague		
26	206740-0-00	2	passafilo	thread guide	passe-fil		
27	206296-0-00	1	tubetto scarica olio	pipe	tube		
28	744512-4-00	2	vite	screw	vis		
29	207945-0-00	1	piastrina	plate	plaque		
30	207947-0-00	1	piastrina	plate	plaque		
31	207943-2-00	1	guida	guide	guide		
32	207934-4-00	1	guida slitte completa	slides guide assembly	guide coulissant compl.		
33	722063-2-00	3	vite	screw	vis		
34	207948-0-00	1	guarnizione	gasket	garniture		

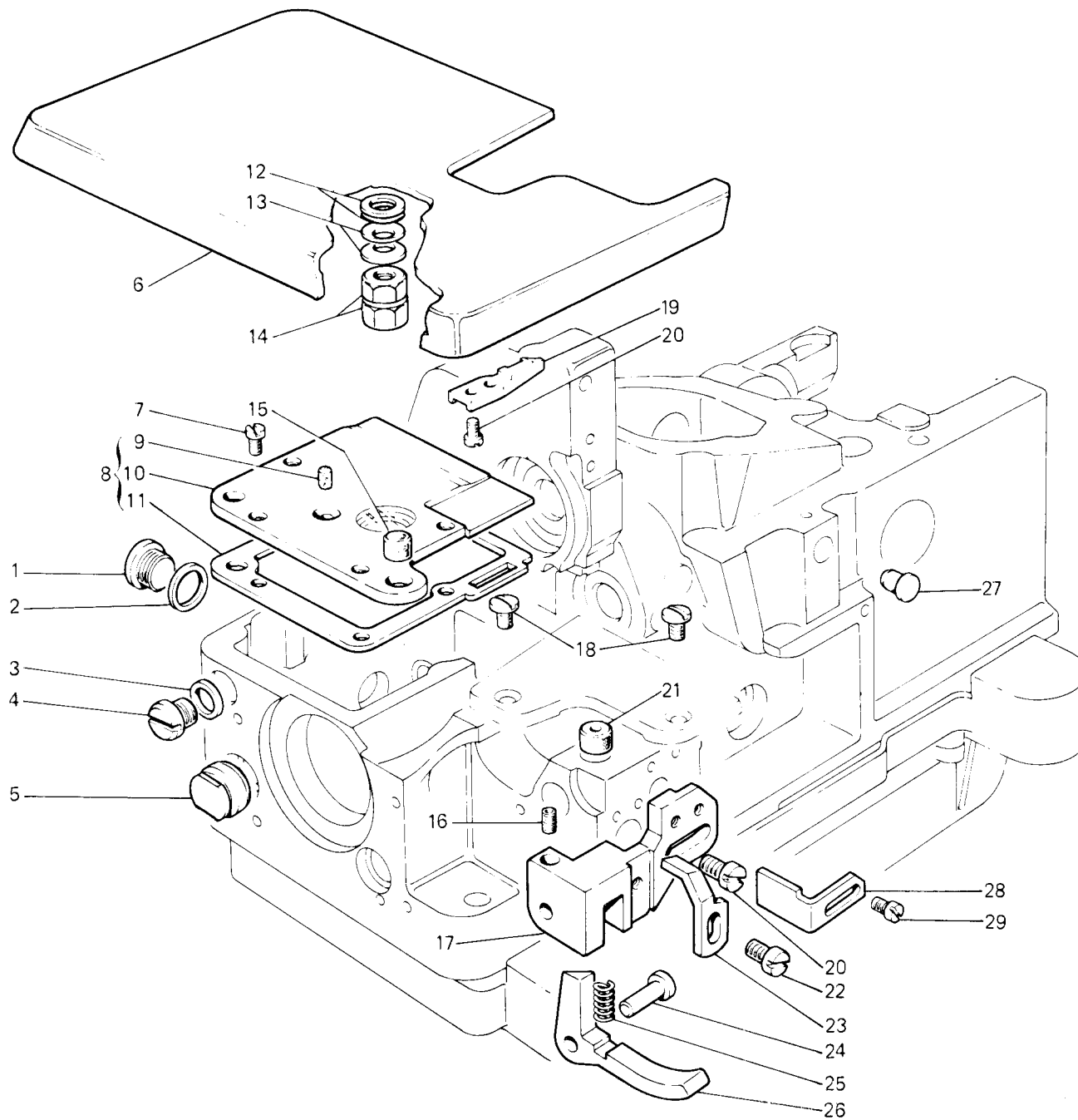

Fig. N. Abb. N.	Part. N. Piece N. Bestell N. Pieza N.	Qt. Anzahl	DESCRIZIONE	DESCRIPTION	DESCRIPTION	BENENNUNG	DESCRIPCION
1	202026-0-10	1	tappo	plug		bouchon	
2	705982-0-00	1	guarnizione	gasket		garniture	
3	705975-0-00	1	guarnizione	gasket		garniture	
4	202480-0-10	1	tappo	plug		bouchon	
5	202027-0-10	1	tappo	plug		bouchon	
6	207955-2-01	1	piano di lavoro	working plate		plan de travail	
7	721443-2-00	4	vite	screw		vis	
8	207951-4-00	1	coperchio completo	cover assembly		couvercle complet	
9	778241-0-00	1	stoppino	wick		mèche	
10	207952-2-00	1	coperchio	cover		couvercle	
11	207953-0-00	1	guarnizione	gasket		garniture	
12	704428-2-00	2	rondella	washer		rondelle	
13	702415-0-00	2	molla a tazza	cup spring		ressort à tasse	
14	208165-0-00	2	dado	nut		écrou	
15	207954-0-01	1	tappo	plug		bouchon	
16	729022-2-00	1	vite	screw		vis	
17	207981-0-00	1	supporto sgancio piano di lavoro	support		support	
18	744742-2-00	2	vite fissa placca ago	screw		vis	
19	207985-0-00	1	gancio arresto piano di lavoro	hook		crochet	
20	721454-2-00	4	vite	screw		vis	
21	207958-0-00	1	tappo	plug		bouchon	
22	741658-2-00	1	vite	screw		vis	
23	207988-0-00	1	squadretta	bracket		équerre	
24	207980-0-00	1	perno	pin		pivot	
25	307137-0-00	1	molla	spring		ressort	
26	207983-0-00	1	leva per sgancio	lever		levier	
27	202398-0-10	1	tappo	plug		bouchon	
28	207984-0-00	1	squadretta	bracket		équerre	
29	721412-2-00	2	vite	screw		vis	

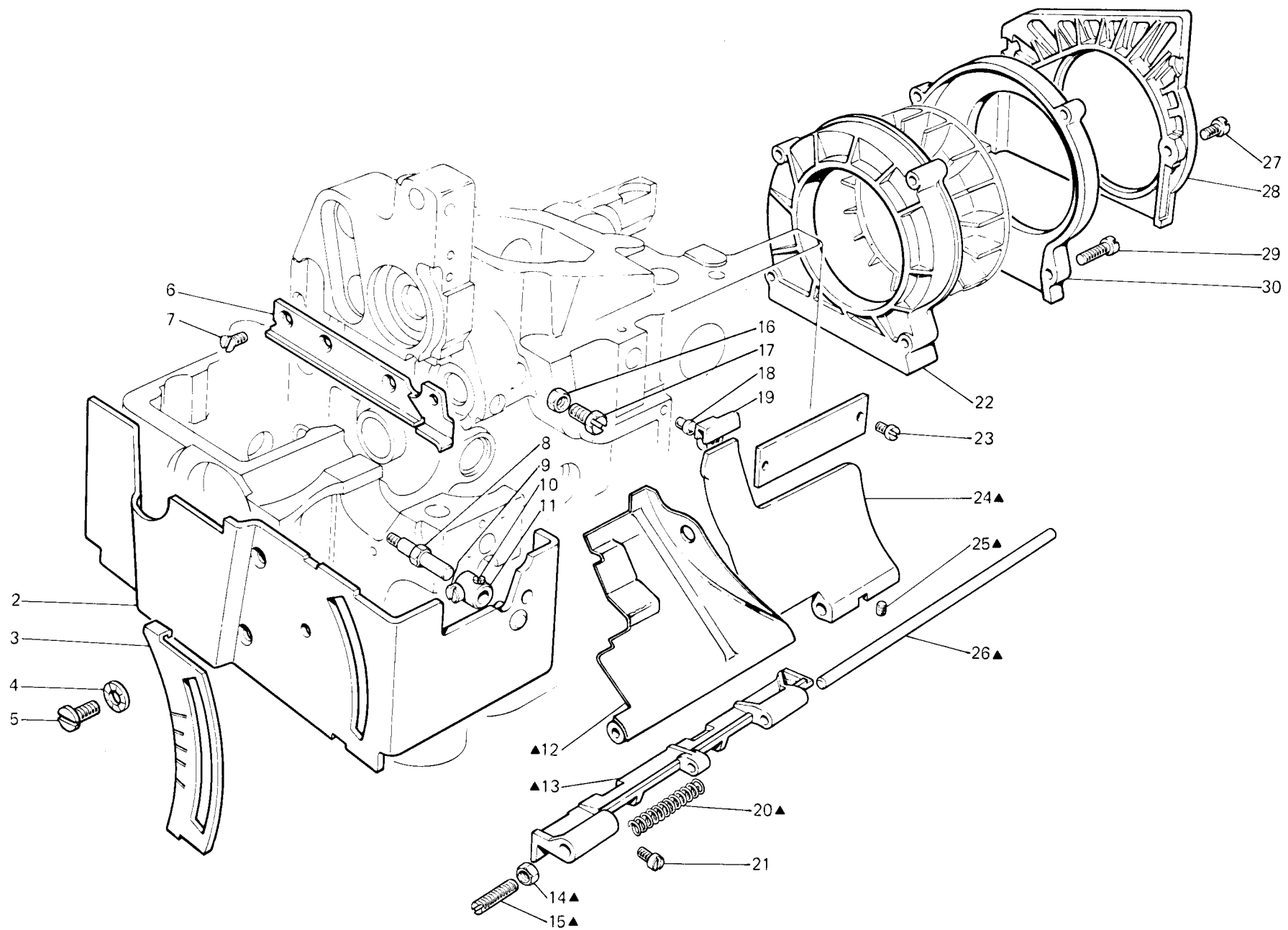

Fig. N. Abb. N.	Part. N. Piecce N. Bestell N. Pieza N.	Qt. Anzahl	DESCRIZIONE	DESCRIPTION	DESCRIPTION	BENENNUNG	DESCRIPCION
▲	208073-4-00	1	sportello anteriore completo	front cover assembly			carter avant complet
2	208028-2-00	1	carter laterale	side cover			carter latéral
3	206797-0-00	1	piastrina	plate			plaque
4	703405-0-00	4	rondella elastica	spring washer			rondelle élastique
5	724895-2-00	4	vite	screw			vis
6	207961-0-00	1	carterino	carter			carter
7	744730-2-00	3	vite	screw			vis
8	206733-0-01	1	vite per carter laterale	screw			vis
9	721435-2-00	1	vite	screw			vis
10	730023-2-00	1	vite	screw			vis
11	206734-2-00	1	morsetto con viti	clamp with screws			collier de serrage avec vis
12	207728-2-00	1	sportello scorrevole	sliding cover			carter coulissant
13	206756-0-01	1	cerniera	hinge			charnière
14	746208-2-00	1	dado	nut			écrou
15	206769-0-10	1	vite di regolazione	adjustment screw			vis de réglage
16	746007-2-00	1	dado	nut			écrou
17	202214-0-11	1	vite	screw			vis
18	207856-0-00	1	gommino	dumper			caoutchouc
19	206764-0-00	1	zoccolo	block			socle
20	206768-0-00	1	molla	spring			ressort
21	721443-2-00	4	vite	screw			vis
22	206688-0-00	1	coclea per ventola	scroll			palier
23	202165-0-11	2	vite	screw			vis
24	207858-0-00	1	sportello ribaltabile	tipping cover			carter amovible
25	745800-2-00	1	vite	screw			vis
26	206767-0-00	1	perno	pin			pivot
27	722063-2-00	2	vite per coperchio	screw			vis
28	206685-0-00	1	coperchio cinghia	cover			couvercle
29	202484-0-10	4	vite	screw			vis
30	206687-2-00	1	coperchio coclea	scroll cover			couvercle palier

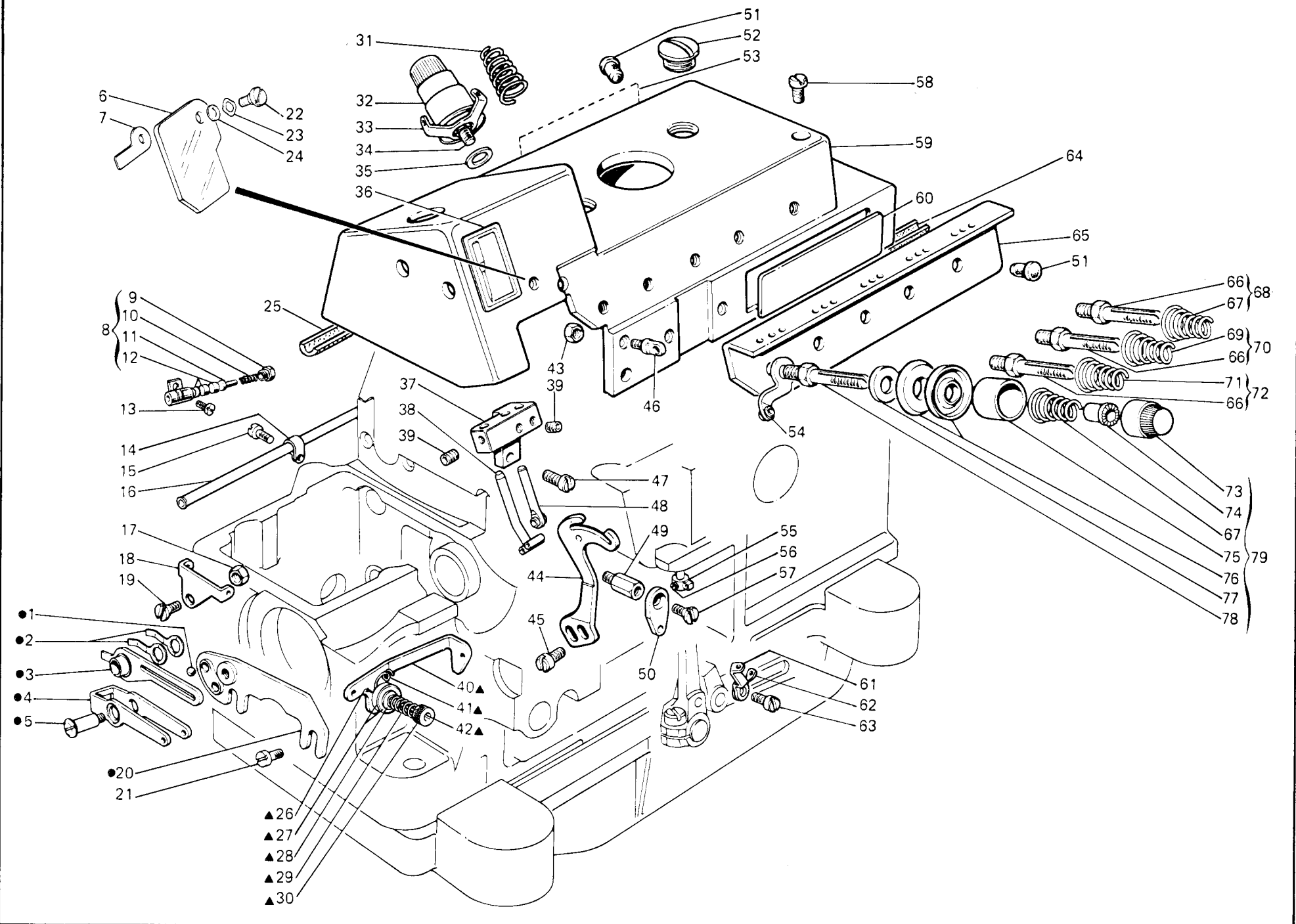

Fig. N. Abb. N.	Part. N. Piecce N. Bestell N. Pieza N.	Qt. Anzahl	DESCRIZIONE	DESCRIPTION	DESCRIPTION
●	206091-4-02	1	gruppo passafili per camma	thread guide assembly for cam	groupe passe-fils pour came
▲	208256-4-00	1	tensione del crochet compl.	tension	tension
1	707602-0-00	1	sfera	ball	sphère
2	207224-0-10	2	molla	spring	ressort
3	207221-2-10	1	passafilo	thread guide	passe-fil
4	206090-0-10	1	passafilo laterale	side thread guide	passe-fil latéral
5	207225-0-10	1	vite	screw	vis
6	208221-0-00	1	piastrina protezione	plate	plaque
7	208222-0-00	1	piastrina	plate	plaque
8	207552-4-00	1	pressafilo completo dell'ago	thread presser assembly	presse-fil complet
9	202260-0-10	1	tappo	plug	bouchon
10	202257-0-10	1	molla	spring	ressort
11	202258-0-10	1	perno	pin	pivot
12	203635-0-10	3	pastiglia	plug	bouchon
13	207562-0-00	1	vite	screw	vis
14	204756-0-10	1	fascetta	clamp	bride
15	741559-2-00	1	vite	screw	vis
16	204704-0-10	1	tubetto	pipe	tube
17	733505-2-00	1	dado	nut	écrou
18	204747-0-10	1	passafilo	thread guide	passe-fil
19	724422-2-00	1	vite	screw	vis
20	207219-0-10	1	supporto	support	support
21	721424-2-00	2	vite	screw	vis
22	208224-0-00	1	vite	screw	vis
23	208220-0-00	1	anello elastico	spring ring	anneau ressort
24	704630-0-00	1	rondella	washer	rondelle
25	208091-0-01	1	guarnizione	gasket	garniture
26	704004-0-00	1	rondella	washer	rondelle
27	200324-0-10	2	disco	disc	disque
28	704218-2-00	1	rondella	washer	rondelle
29	930845-0-00	1	molla	spring	ressort
30	300387-0-10	1	pomolo	knob	pommeau
31	203457-0-10	1	molla per tensione fig. 32	spring for tension fig. 32	ressort pour tension fig. 32
32	206340-4-00	1	tensione completa con fig. 31-34	tension assembly with fig. 31-34	tension complète avec fig. 31-34
33	308503-0-01	1	passafilo	thread guide	passe-fil
34	202225-0-11	1	perno per tensione fig. 32	pin for tension fig. 32	pivot pour tension fig. 32
35	705013-0-00	1	rondella	washer	rondelle
36	788006-0-01	1	decalcomania sist. aghi	sys. needles decalcomania	décalcomanie syst. aiguilles
37	209767-0-00	1	supporto passafili aghi	support	support
38	205052-2-13	1	passafilo ago	thread guide of needle	passe-fil de l'aiguille
39	745800-2-00	2	vite	screw	vis
40	206876-0-01	1	passafilo	thread guide	passe-fil
41	304815-0-10	1	passafilo	thread guide	passe-fil
42	208255-0-00	1	perno a vite	thread pin	pivot à vis
43	733503-0-00	3	dado	nut	écrou
44	207873-0-00	1	tendifilo ago	needle thread guide	tendeur du fil aiguille
45	741558-0-00	2	vite	screw	vis
46	206711-0-00	3	passafilo	thread guide	passe-fil
47	741956-2-00	2	vite	screw	vis
48	208184-2-00	1	passafilo	thread guide	passe-fil

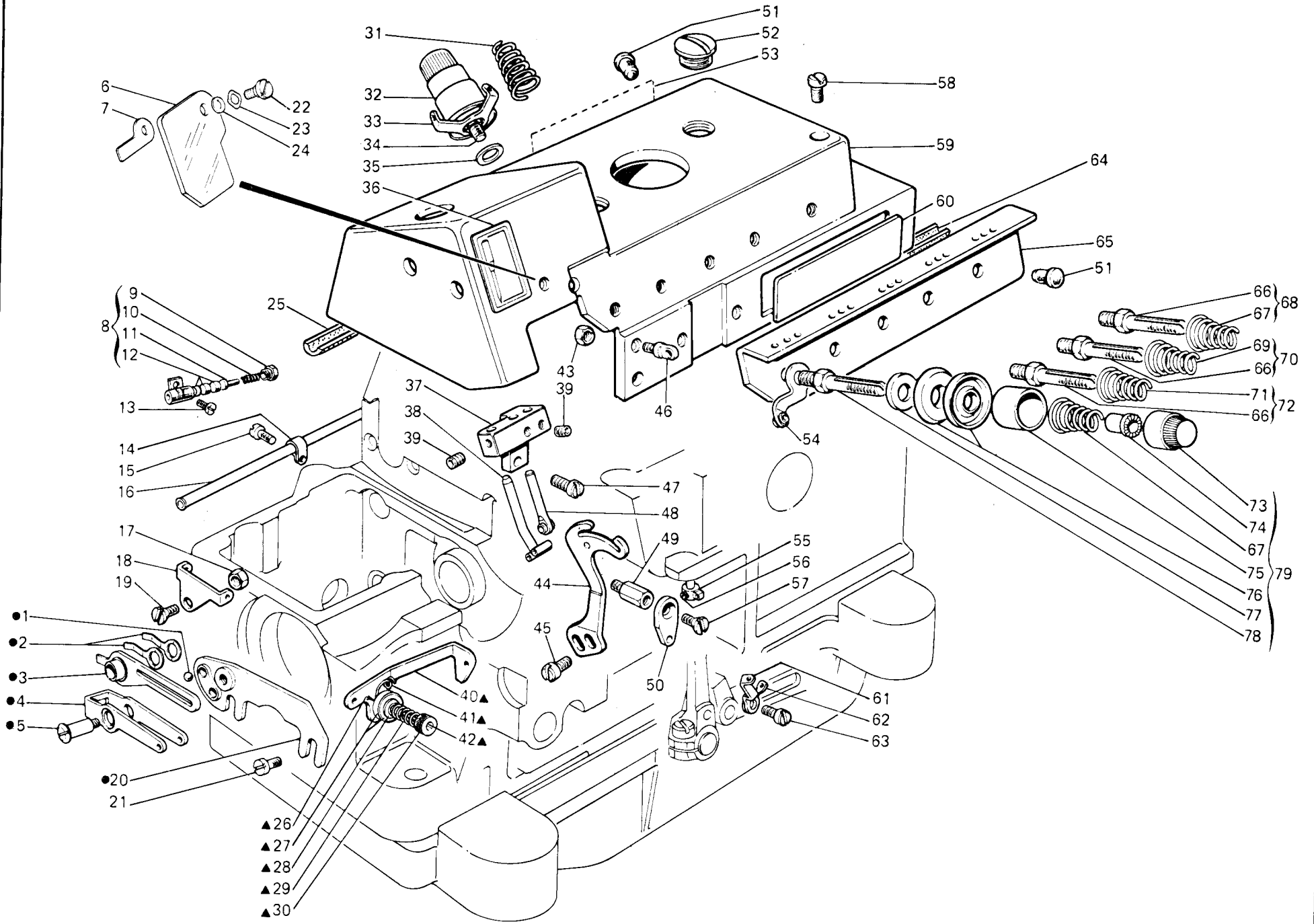

Fig. N. Abb. N.	Part. N. Piece N. Bestell N. Pieza N.	Qt. Anzahl	DESCRIZIONE	DESCRIPTION	DESCRIPTION
49	206755-0-00	1	colonnina per passafilo	threaded tube	tube pour passe-fil
50	206812-0-00	1	passafilo crochet superiore	thread guide for upper looper	passe-fil pour crochet supérieur
51	207893-0-00	2	tappo	plug	bouchon
52	207968-0-01	2	tappo	plug	bouchon
53	207668-0-00	1	decalcomania	decalcomania	décalcomanie
54	206713-2-00	1	passafilo	thread guide	passe-fil
55	203135-2-10	1	passafilo	thread guide	passe-fil
56	745002-0-00	1	vite	screw	vis
57	744631-2-00	1	vite	screw	vis
58	721484-2-00	3	vite fissa coperchio sup.	screw	vis
59	207910-0-00	1	coperchio superiore	upper cover	couvercle supérieur
60	207669-0-00	1	targhetta	plate	plaque
61	202279-0-10	1	tendifilo	thread take-up	tendeur du fil
62	202281-0-10	1	passafilo	thread guide	passe-fil
63	741675-0-00	1	vite	screw	vis
64	208090-0-01	1	guarnizione	gasket	garniture
65	207919-0-00	1	piastra passafili	thread guide plate	plaque pour passe-fil
66	206747-0-01	3	perno	pin	pivot
67	202227-0-10	2	molla	spring	ressort
68	206341-4-00	1	tensione completa	tension assembly	tension complète
69	202681-0-10	1	molla	spring	ressort
70	206343-4-00	1	tensione completa	tension assembly	tension complète
71	202228-0-10	1	molla	spring	ressort
72	206342-4-00	1	tensione completa	tension assembly	tension complète
73	202558-2-00	5	pomolo	knob	pommeau
74	202229-0-10	5	bussola	bush	bague
75	202556-0-10	5	scodellino	cup	cuvette
76	300218-0-10	10	disco tensione	tension disc	disque tension
77	206754-0-00	5	rondella	washer	rondelle
78	208169-0-00	1	perno	pin	pivot
79	208172-4-00	1	tensione completa	tension assembly	tension complète

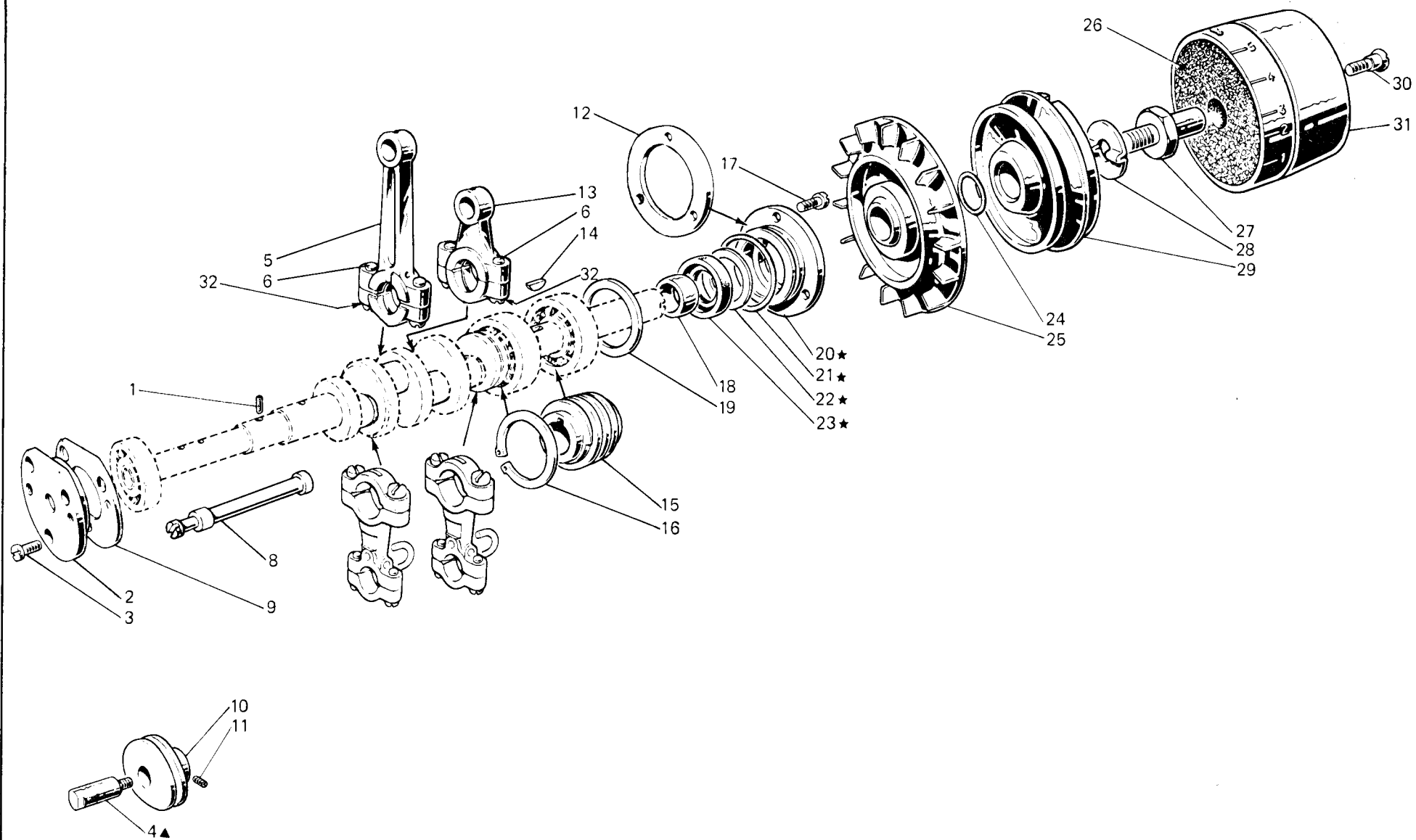

Fig. N. Abb. N.	Part. N. Bestell N. Piece N. Pieza N.	Qt. Anzahl	DESCRIZIONE	DESCRIPTION	DESCRIPTION	BENENNUNG	DESCRIPCION
★	206697-4-01	1	gruppo flangia con anelli	flange with ring			
1	206708-0-00	1	stoppino	wick	groupe flasque avec bagues		
2	206860-0-01	1	flangia sinistra	left flange	mèche		
3	741956-2-00	3	vite	screw	flasque gauche		
4	204757-0-11	1	perno porta camma	pin	vis		
5	208520-2-10	1	biella albero sup. con vite	con-rod with screw	pivot		
6	743469-2-00	4	vite	screw	bielle arbre sup. avec vis		
8	206969-0-00	1	limitatore olio	oil limiter	vis		
9	206543-0-01	1	guarnizione	gasket	limitateur d'huile		
10	206994-2-01	1	camma tendifilo con viti	thread guide with screws	garniture		
11	727203-0-00	2	vite	screw	came tendeur du fil avec vis		
12	206544-0-00	1	guarnizione	gasket	vis		
13	208521-2-00	1	biella com. alb. colt. sup.	con-rod for upper knife	garniture		
14	204122-0-10	1	chiavetta	key	bielle comm. arbre couteau sup.		
15	206556-0-01	1	vite senza fine	worm screw	clavette		
16	202386-0-10	1	anello elastico	spring ring	vis sans fin		
17	722063-2-00	3	vite	screw	anneau ressort		
18	206692-0-00	1	distanziale albero principale	spacer	vis		
19	206689-0-01	1	anello compensazione	ring	entretoise		
20	206699-0-01	1	flangia	flange	anneau		
21	701133-0-00	1	anello di tenuta	circlip	flasque		
22	206693-0-00	1	rondella	washer	circlip		
23	700630-0-00	1	anello di tenuta	circlip	rondelle		
24	701116-0-00	1	anello di tenuta	circlip	circlip		
25	206690-2-00	1	ventola di raffreddamento	cooling fan	circlip		
26	206507-0-00	1	tampone per volantino	pad	ventilateur		
27	206683-0-00	1	perno volantino	pin	tampon		
28	206684-0-10	1	chiavetta albero principale	key	pivot		
29	206508-0-00	1	volantino	handwheel	clavette		
30	202492-0-10	1	vite	screw	volant		
31	206679-0-00	1	coperchio volantino	handwheel cover	vis		
32	704213-2-00	4	rondella	washer	couvercle volant		
					rondelle		

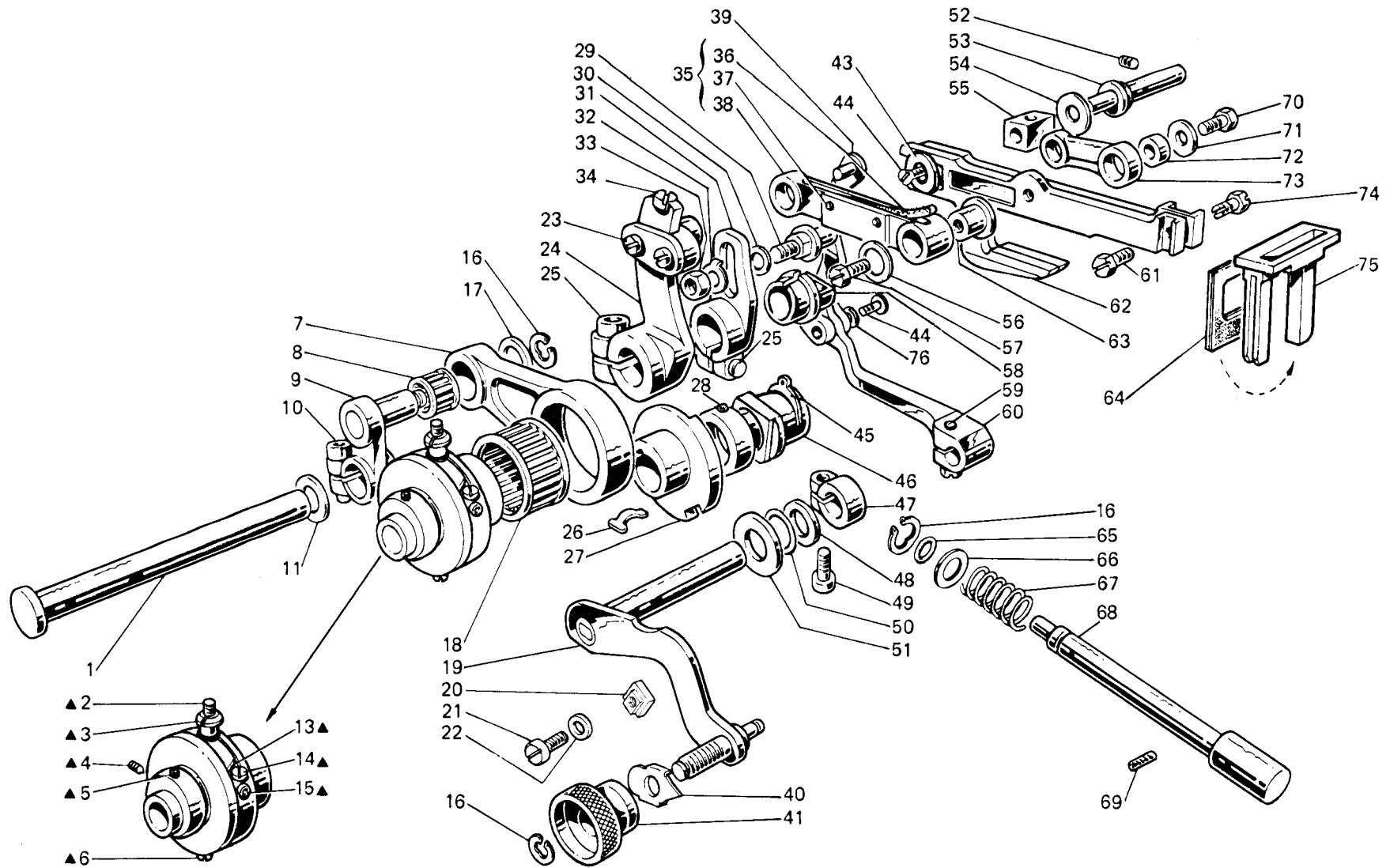

Fig. N. Abb. N.	Part. N. Pezce N. Bestell N. Pieza N.	Qt. Anzahl	DESCRIZIONE	DESCRIPTION	DESCRIPTION	BENENNUNG	DESCRIPCION
▲	207698-4-00	1	gruppo eccentr. regol. trasporto	eccentric group	groupe excentrique		
1	206593-0-00	1	contralbero trasporto	transport countershaft	axe-transport		
2	729051-2-00	1	vite	screw	vis		
3	206603-0-11	1	fermo eccentrico	eccentric retainer	pièce blocage excentrique		
4	745815-2-00	1	vite	screw	vis		
5	778401-0-00	1	stoppino	wick	mèche		
6	727884-0-00	1	vite	screw	vis		
7	206599-0-10	1	biella comando trasporto	transport con-rod control	bielle commande transport		
8	201358-0-10	1	gabbia a rullini	needles cage	cage à aiguilles		
9	206598-3-00	1	braccio a manovella con vite	crank arm with screw	bras à manivelle avec vis		
10	744334-2-00	1	vite	screw	vis		
11	704841-0-00	1	rondella	washer	rondelle		
13	202412-0-11	1	lardone	gib	lardon		
14	202473-0-11	2	vite	screw	vis		
15	730011-2-00	2	vite	screw	vis		
16	700207-0-00	3	anello elastico	spring ring	anneau ressort		
17	206546-0-00	1	rondella	washer	rondelle		
18	202385-0-10	1	gabbia a rullini	needles cage	cage à aiguilles		
19	206790-2-11	1	leva comando slitta	lever	levier		
20	211612-0-01	2	arresto regolabile	external retainer	butée réglable		
21	721475-2-00	2	vite	screw	vis		
22	704409-2-00	2	rondella	washer	rondelle		
23	741546-2-00	2	vite	screw	vis		
24	206592-3-00	1	manovella trasporto con viti	transport crank with screw	manivelle transport avec vis		
25	744332-2-00	2	vite	screw	vis		
26	206872-0-00	1	molla	spring	ressort		
27	206605-0-01	1	eccentrico	eccentric	excentrique		
28	745812-2-00	2	vite	screw	vis		
29	202063-0-10	1	spina	pin	goupille		
30	704808-0-00	1	rondella	washer	rondelle		
31	206584-2-00	1	braccio manovella	crank arm	bras à manivelle		
32	206580-2-00	1	rondella con spina	washer with pin	rondelle avec goupille		
33	746008-0-00	1	dado	nut	écrou		
34	741413-2-00	1	vite	screw	vis		
35	206615-4-00	1	biellino completo	con-rod assembly	petite bielle complète		
36	778417-0-00	1	stoppino	wick	mèche		
37	200490-0-00	2	spillo	needle	épingle		
38	206587-0-01	1	biellino	con-rod	petite bielle		
39	207724-2-00	1	giunto	joint	joint		
40	206796-0-00	1	indice rapp. differ.	differential index	indice différentiel		
41	206798-0-00	1	bottone rapp. differenziale	differential button	bouton différentiel		
43	202475-0-01	1	rondella	washer	rondelle		
44	724032-0-00	2	vite	screw	vis		
45	201610-0-01	1	anello elastico	spring ring	anneau ressort		

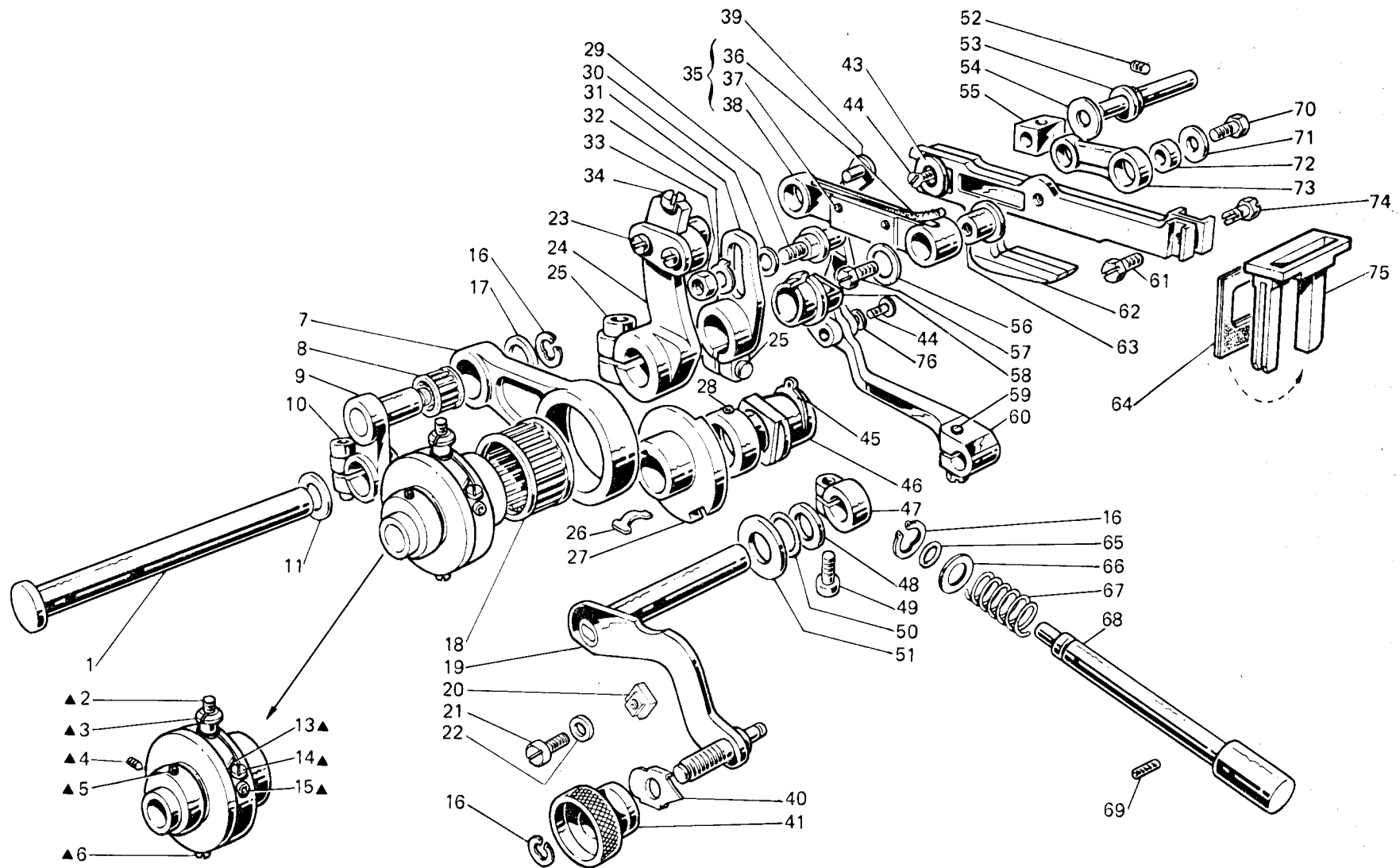

Fig. N. Abb.	Part. N. Peece N. Bestell N. Peza N.	Qt. Anzahl	DESCRIZIONE	DESCRIPTION	DESCRIPTION	BENENNUNG	DESCRIPCION
46	206617-0-01	1	blocchetto	block	bloc		
47	100620-2-10	1	morsetto con vite	clamp with screw	collier de serrage avec vis		
48	704829-0-00	1	rondella	washer	rondelle		
49	741745-2-00	1	vite	screw	vis		
50	701007-0-00	1	anello di tenuta	circlip	circlip		
51	705230-0-00	1	rondella	washer	rondelle		
52	202478-0-10	1	vite	screw	vis		
53	206613-0-00	1	perno eccentrico	eccentric pin	pivot excentrique		
54	705408-0-00	1	rondella	washer	rondelle		
55	202033-0-10	1	blocchetto	block	bloc		
56	705008-0-00	1	rondella	washer	rondelle		
57	206588-0-00	1	vite	screw	vis		
58	206619-0-00	1	vaschetta olio	oil sump	cuvette huile		
59	740053-2-00	1	vite	screw	vis		
60	207711-2-10	1	braccio regol. differenziale	differential arm	bras différentiel		
61	202489-0-10	1	vite	screw	vis		
62	207942-3-00	1	gruppo slitta porta griffe	feed dog slide group	groupe glissière porte-griffe		
63	206586-0-01	1	bussola per biellino	bush	bague		
64	207944-0-00	2	guarnizione raschia olio	oil scraper gasket	garniture râcheur d'huile		
65	701004-0-00	1	anello	ring	anneau		
66	704314-2-00	1	rondella	washer	rondelle		
67	202408-0-10	1	molla	spring	ressort		
68	206618-0-10	1	pulsante reg. punto	bush-button	poussoir réglable point		
69	729032-2-00	1	vite	screw	vis		
70	202490-0-10	1	vite	screw	vis		
71	705208-0-00	1	rondella	washer	rondelle		
72	202032-0-11	1	bussolina	bush	bague		
73	206583-0-00	1	biellino	con-rod	petite bielle		
74	202488-0-10	1	vite	screw	vis		
75	207946-0-00	1	telaio raschia olio	oil scraper frame	râcheur d'huile		
76	207719-0-01	1	rondella	washer	rondellé		

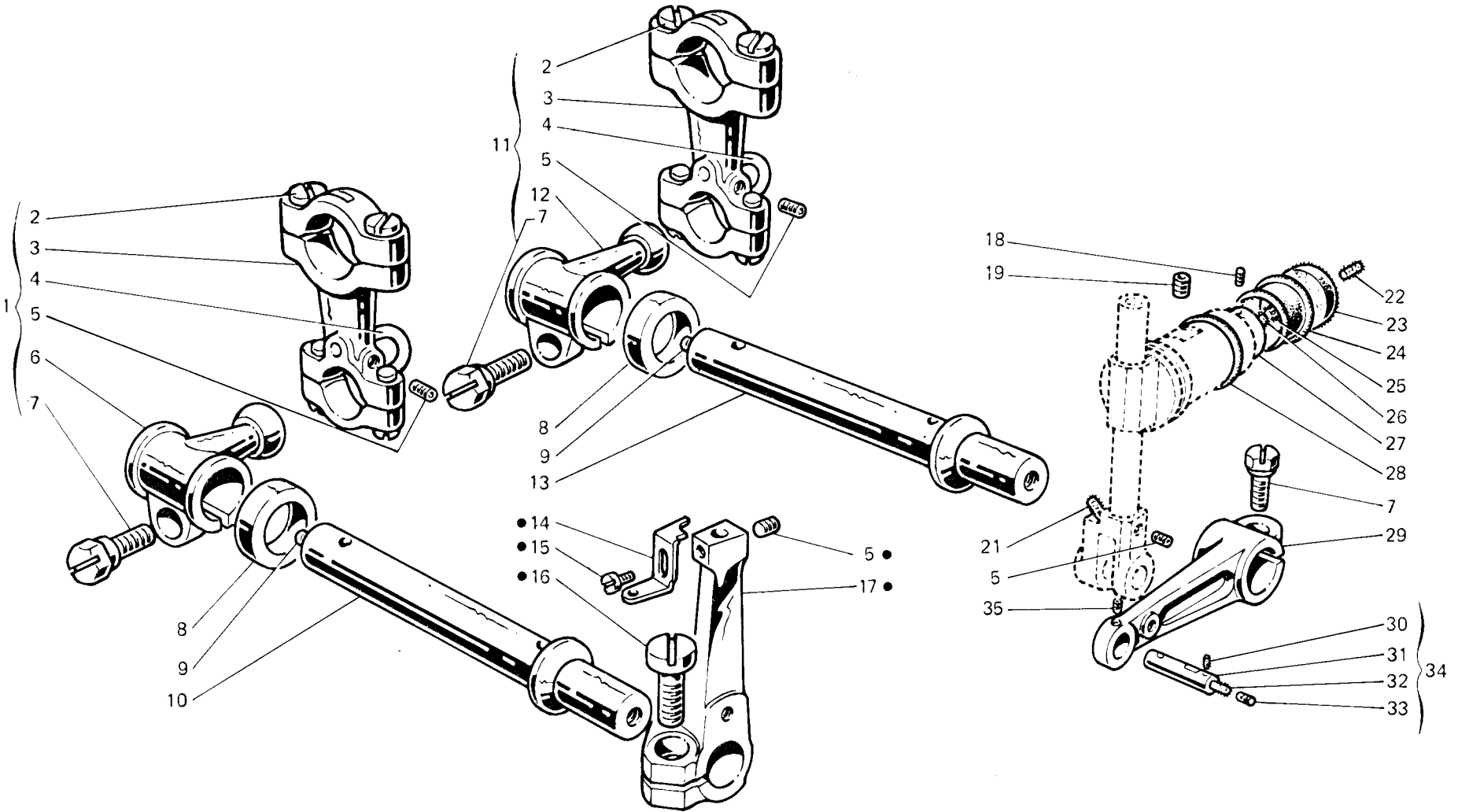

Fig. N. Abb N.	Part. N. Piece N. Bestell N. P.eza N.	Qt. Anzahl	DESCRIZIONE	DESCRIPTION	DESCRIPTION	BENENNUNG	DESCRIPCION
●	208039-4-00	1	gruppo porta crochet inferiore	lower looper assembly	groupe porte crochet inférieur		
1	206453-4-00	1	gruppo manicotto con biella	coupling assembly with con-rod	groupe manchon avec bielle		
2	722089-2-00	8	vite per biella	screw	vis		
3	209270-2-01	2	biella con viti	con-rod with screw	bielle avec vis		
4	209272-0-00	2	cavallotto	coupling	cavalier		
5	745812-2-00	4	vite	screw	vis		
6	206659-2-02	1	manicotto	coupling	manchon		
7	201128-0-10	3	vite	screw	vis		
8	704847-0-00	2	rondella	washer	rondelle		
9	206695-0-00	2	tappo per albero	plug for shaft	bouchon pour arbre		
10	207096-2-00	1	albero crochet inferiore	shaft lower looper	arbre crochet inférieur		
11	206455-4-01	1	gruppo manicotto con biella	coupling with con-rod	groupe manchon avec bielle		
12	207730-2-02	1	manicotto	coupling	manchon		
13	207095-2-00	1	albero crochet superiore	upper looper shaft	arbre crochet supérieur		
14	208015-0-00	1	squadretta	bracket	équerre		
15	741415-2-00	1	vite	screw	vis		
16	721883-0-00	1	vite	screw	vis		
17	206654-2-10	1	porta crochet inf.	lower looper holder	porte crochet inférieur		
18	745800-2-00	1	vite	screw	vis		
19	745168-0-00	1	vite	screw	vis		
21	778403-0-00	1	stoppino	wick	mèche		
22	778236-0-00	1	stoppino	wick	mèche		
23	206686-0-00	1	disco lubrificazione guida	disc	disque		
24	202720-0-00	1	paraolio	oil retainer	pare-huile		
25	778405-0-00	1	stoppino	wick	mèche		
26	778410-0-00	1	stoppino	wick	mèche		
27	202062-2-10	1	anello con vite	ring with screw	anneau avec vis		
28	701113-0-00	1	anello di tenuta	circlip	circlip		
29	206653-2-01	1	braccio	arm	bras		
30	778202-0-00	4	stoppino	wick	mèche		
31	202086-0-11	1	spina	pin	goupille		
32	778401-0-00	1	stoppino	wick	mèche		
33	745002-0-00	1	vite	screw	vis		
34	206645-4-02	1	spina completa	pin assembly	goupille compl.		
35	745810-2-00	1	vite	screw	vis		

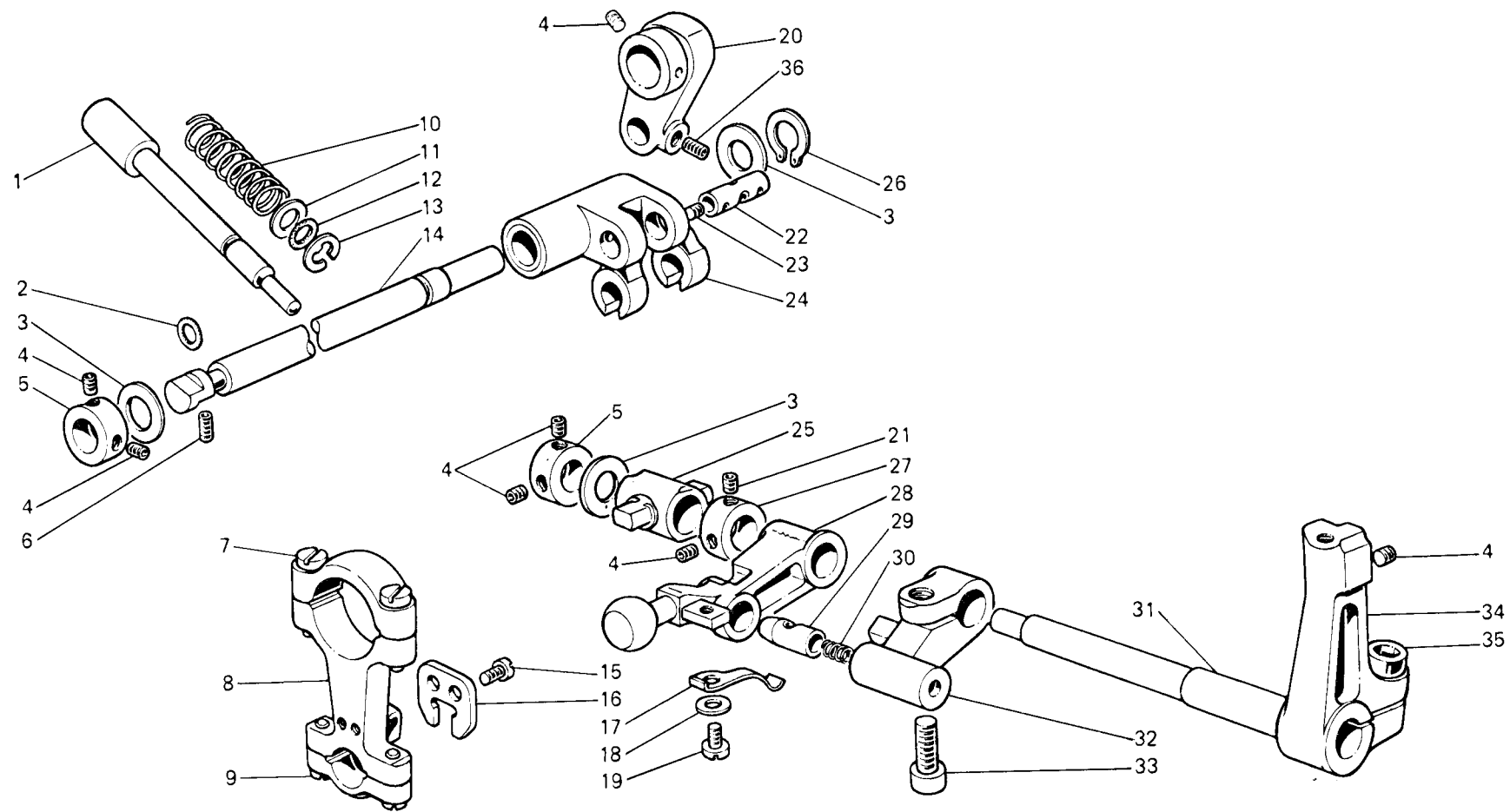

Fig. N. Abb. N.	Part. N. Bestell. N. Pieze N.	Qt. Anzahl	DESCRIZIONE	DESCRIPTION	DESCRIPTION	BENENNUNG	DESCRIPCION
1	207708-0-00	1	pulsante	push-button	poussoir		
2	701007-0-00	1	anello di tenuta	retainer ring	bague d'étanchéité		
3	704825-0-00	3	rondella	washer	rondelle		
4	745812-2-00	8	vite	screw	vis		
5	207692-2-00	2	anello di registro	adjustment ring	bague de réglage		
6	729032-2-00	1	vite	screw	vis		
7	722119-2-00	2	vite	screw	vis		
8	209309-2-00	1	biella comando crochet	looper control con-rod	bielle commande crochet		
9	722089-2-00	2	vite	screw	vis		
10	311069-0-00	1	molla	spring	ressort		
11	704314-2-00	1	rondella	washer	rondelle		
12	701004-0-00	1	anello di tenuta	retainer ring	bague d'étanchéité		
13	700207-0-00	1	anello elastico	spring ring	anneau ressort		
14	207690-0-00	1	perno	pin	pivot		
15	741558-0-00	2	vite	screw	vis		
16	207700-0-00	1	forcellino	fork	fourche		
17	207702-0-00	1	molla	spring	ressort		
18	704205-2-00	1	rondella	washer	rondelle		
19	741620-2-00	1	vite	screw	vis		
20	207685-3-01	1	biellino	con-rod	petite bielle		
21	730022-2-00	1	vite	screw	vis		
22	207687-0-00	1	spinotto	pin	goupille		
23	745002-0-00	1	vite	screw	vis		
24	207688-2-00	1	leva con bussole	lever with bush	levier avec bague		
25	207691-0-00	1	crociera	coupling	croisière		
26	700008-0-00	1	anello elastico	spring ring	anneau ressort		
27	207693-2-00	1	anello di registro	adjustment ring	bague de réglage		
28	207701-0-00	1	leva comando crochet	lever for looper control	levier commande crochet		
29	304172-0-10	1	perno	pin	pivot		
30	304195-0-10	1	molla	spring	ressort		
31	207704-0-00	1	albero porta crochet	looper shaft	arbre porte crochet		
32	207703-2-00	1	manicotto con vite	coupling with screw	manchon avec vis		
33	722443-2-00	1	vite	screw	vis		
34	207721-2-02	1	porta crochet con viti	looper holder with screws	porte crochet avec vis		
35	742232-2-00	1	vite	screw	vis		
36	729422-2-00	1	vite	screw	vis		

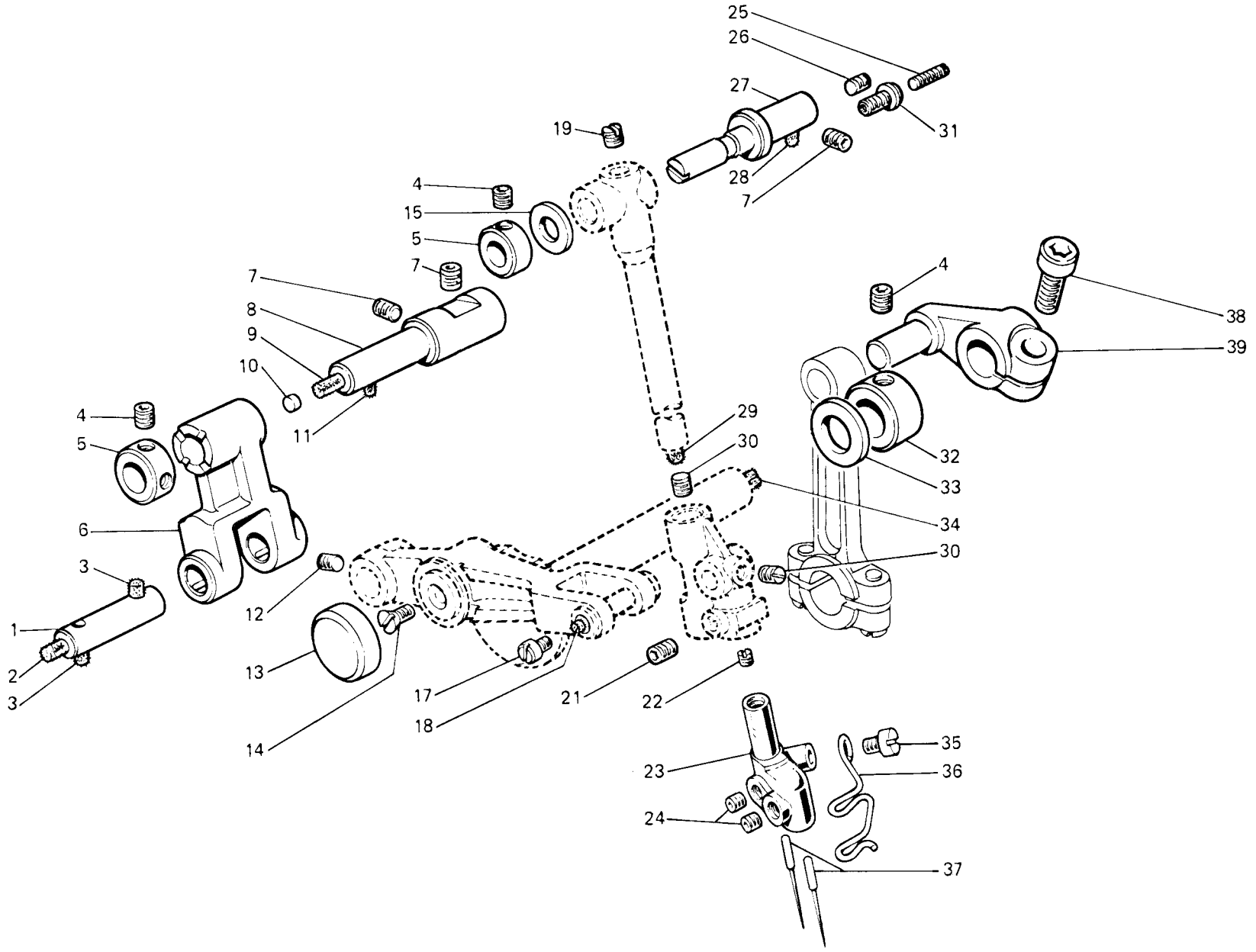

Fig. N. Abb. N.	Part. Piec Bestell Pieza	N. N. N. N.	Qt. Anzahl	DESCRIZIONE	DESCRIPTION	DESCRIPTION
1	207930-0-10		1	spina	pin	goupille
2	778414-0-00		1	stoppino	wick	mèche
3	778204-0-00		3	stoppino	wick	mèche
4	745812-2-00		5	vite	screw	vis
5	207692-2-00		2	anello di rasamento con viti	ring with screw	anneau avec vis
6	207932-0-10		1	leva	lever	levier
7	729034-2-00		3	vite	screw	vis
8	208163-4-11		1	perno con stoppini e tappo	pin with wick and plug	pivot avec mèche et bouchon
9	778417-0-00		1	stoppino	wick	mèche
10	206521-0-00		1	tappo	plug	bouchon
11	778511-0-00		2	stoppino	wick	mèche
12	745114-0-00		1	vite	screw	vis
13	206533-0-00		1	coperchio per leva	cover for lever	couvercle pour levier
14	724460-0-00		1	vite	screw	vis
15	309560-0-00		1	rondella	washer	rondelle
17	741405-0-00		1	vite	screw	vis
18	778208-0-00		1	stoppino	wick	mèche
19	310167-0-00		1	vite	screw	vis
21	729012-2-00		1	vite	screw	vis
22	727021-5-00		1	vite	screw	vis
23	207526-2-00		1	morsetto porta aghi	needles clamp	porte-aiguilles
24	745810-2-00		2	vite	screw	vis
25	729051-2-00		1	vite	screw	vis
26	727014-2-00		1	vite	screw	vis
27	207927-0-01		1	perno	pin	pivot
28	778419-0-00		1	stoppino	wick	mèche
29	778503-0-00		1	stoppino	wick	mèche
30	745002-0-00		2	vite	screw	vis
31	206603-0-11		1	vite di fermo	screw	vis
32	206606-0-00		1	anello di rasamento con vite	ring	anneau
33	705030-0-00		1	rondella	washer	rondelle
34	778837-0-00		1	stoppino	wick	mèche
35	741415-2-00		1	vite	screw	vis
36	207543-0-00		1	guidafilo	thread guide	guide-fil
37	765510-6-10		2	ago RIM 29A fin. 100	needle RIM 29A size 100	aiguille RIM 29A jauge 100
38	744334-2-00		1	vite	screw	vis
39	206542-2-10		1	manovella aib. sup. con vite	crank	manivelle

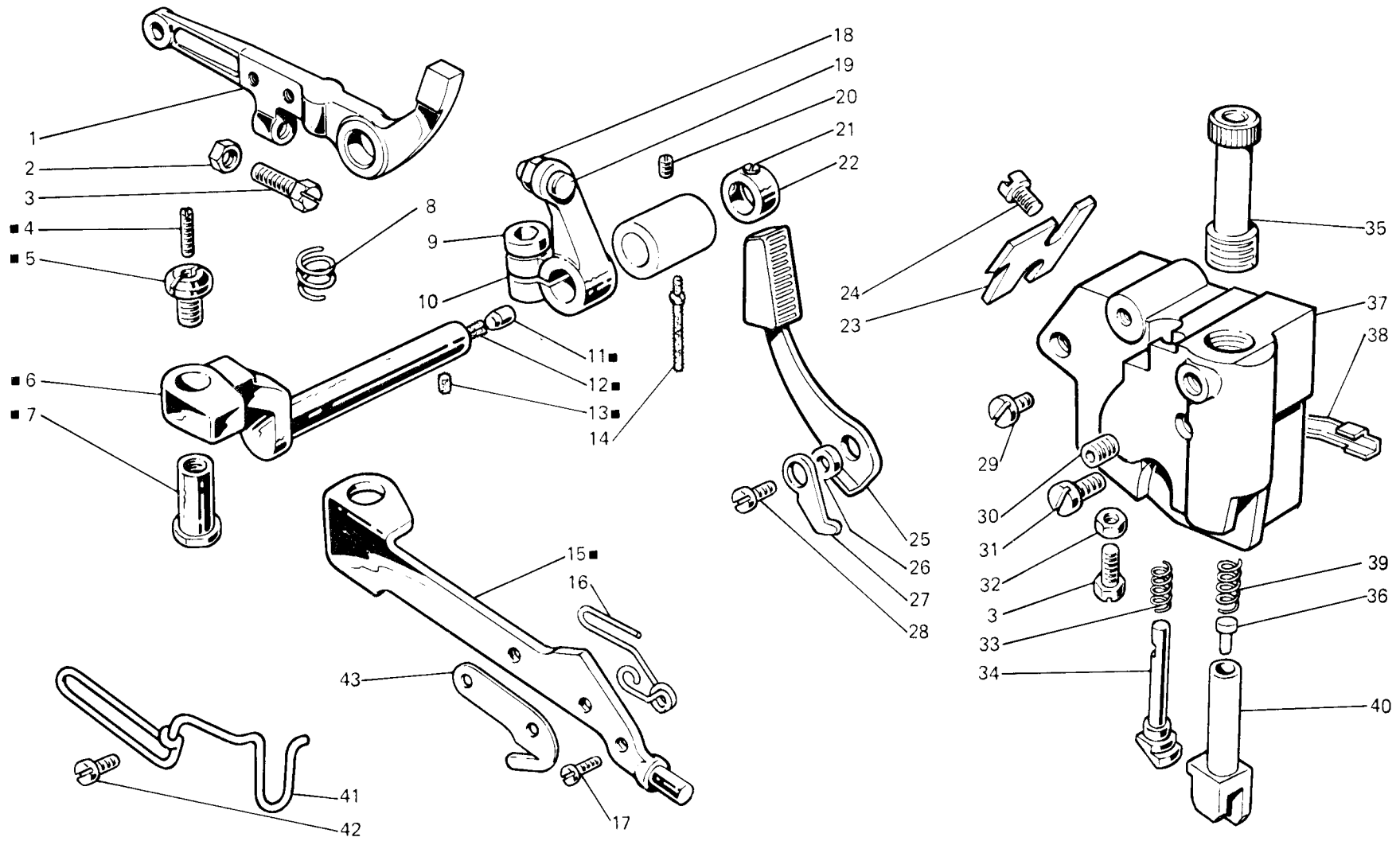

Fig. N. Abb. N.	Part. N. Bestell N. Piece N. Pieza N.	Qt. Anzahl	DESCRIZIONE	DESCRIPTION	DESCRIPTION	BENENNUNG	DESCRIPCION
■	207886-4-00	1	leva premistoffa con perno	presser lever		levier du pied presseur	
1	207881-2-00	1	leva alza premistoffa	lever		levier	
2	733505-2-00	1	dado	nut		écrou	
3	202214-0-11	2	vite	screw		vis	
4	729051-2-00	1	vite	screw		vis	
5	202529-0-10	1	perno di fermo	pin		pivot	
6	207878-3-00	1	perno con tappo e stoppino	pin with plug and wicks		pivot avec bouchon et mèches	
7	206622-0-00	1	spina	pin		goupille	
8	206621-0-00	1	molla richiamo leva alza premist.	spring		ressort	
9	744332-2-00	1	vite	screw		vis	
10	207876-2-00	1	leva arresto premist. con viti	lever		levier	
11	301586-0-10	1	pastiglia	plug		bouchon	
12	778522-0-00	1	stoppino	wick		mèche	
13	778204-0-00	1	stoppino	wick		mèche	
14	206620-0-00	1	stoppino buss.perno leva premist.	wick		mèche	
15	206625-0-01	1	leva	lever		levier	
16	205042-0-11	1	molla premi piedino	spring		ressort	
17	203187-0-10	1	vite	screw		vis	
18	746020-2-00	1	dado	nut		écrou	
19	727096-0-00	1	vite	screw		vis	
20	745812-2-00	1	vite	screw		vis	
21	745114-0-00	2	vite	screw		vis	
22	207882-2-00	1	anello con viti	ring		anneau	
23	207965-0-00	1	arresto	stopping		butée	
24	721434-2-00	2	vite	screw		vis	
25	208133-2-00	1	leva	lever		levier	
26	206637-0-00	1	distanziale	spacer		entretoise	
27	206635-0-00	1	nasello	snug		déclic	
28	722063-2-00	1	vite	screw		vis	
29	722123-2-00	1	vite	screw		vis	
30	202391-0-11	1	vite	screw		vis	
31	206642-0-00	1	vite	screw		vis	
32	746007-2-00	1	dado	nut		écrou	
33	926273-0-00	1	molla	spring		ressort	
34	207959-0-00	1	tirante	tie-rod		tirant	
35	207967-0-01	1	vite	screw		vis	
36	207626-0-00	1	bottono	button		bouton	
37	207960-0-00	1	supporto	support		support	
38	207962-0-00	1	guarnizione per supporto	gasket for support		garniture pour support	
39	205021-0-10	1	molla	spring		ressort	
40	207625-0-00	1	cannotto	column		fourche	
41	990693-0-01	1	salvadita	protection		protection	
42	741453-0-00	2	vite	screw		vis	
43	202194-0-11	1	piastrina tagliafilo	plate		plaque	

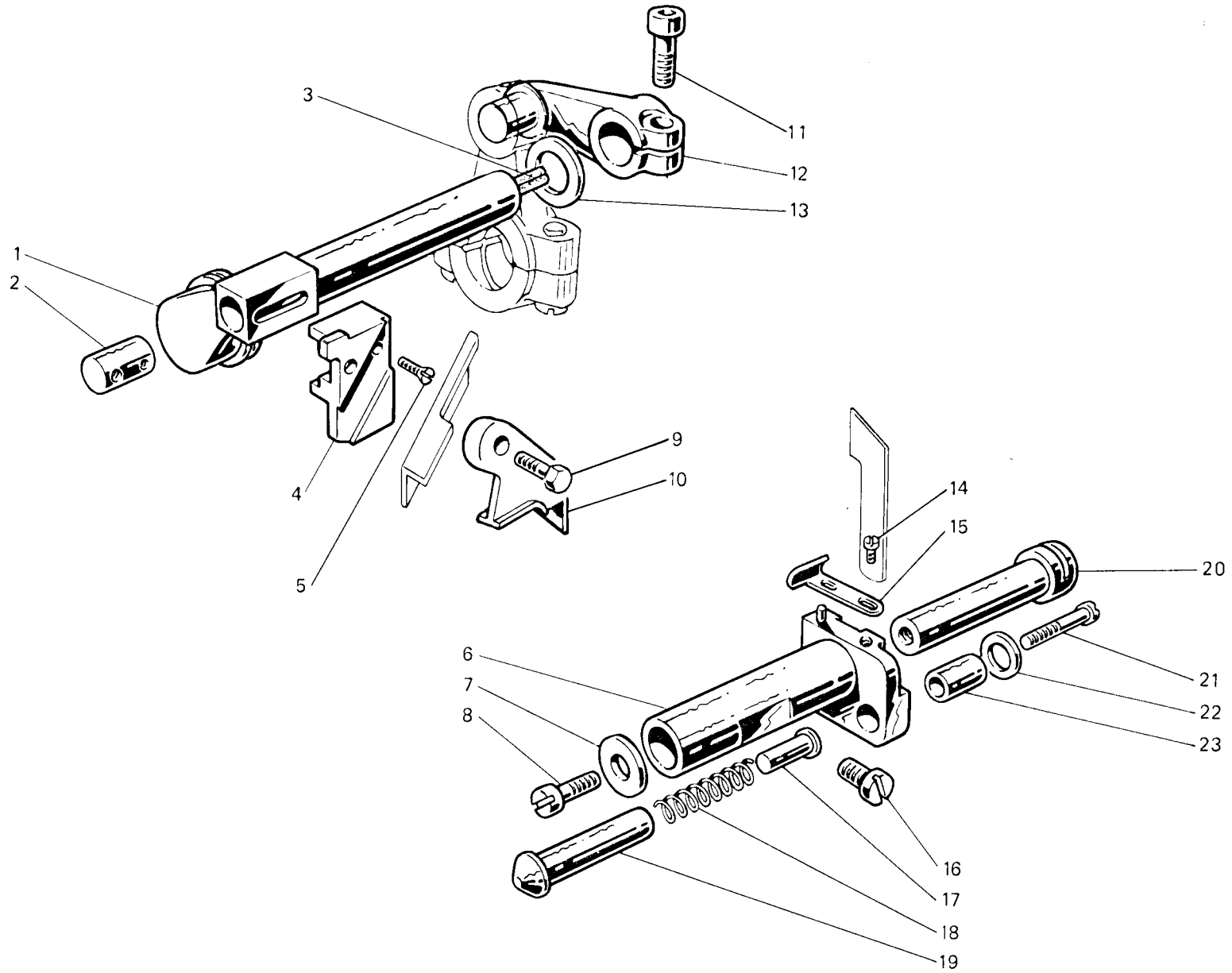

Fig. N. Abb. N.	Part. N. Bestell N. Pieze N. Pieza N.	Qt. Anzahl	DESCRIZIONE	DESCRIPTION	DESCRIPTION	BENENNUNG	DESCRIPCION
1	207861-4-00	1	albero colt.sup. con stoppini	upper knife shaft with wick	arbre couteau sup. avec mèche		
2	202130-0-11	1	perno	pin	pivot		
3	778835-0-00	1	stoppino	wick	mèche		
4	207650-0-01	1	placchetta	plate	plaque		
5	744573-0-00	1	vite	screw	vis		
6	204684-2-11	1	porta coltello inferiore	lower knife holding	porte couteau inférieur		
7	704409-2-00	1	rondella	washer	rondelle		
8	742457-2-00	1	vite fissa coltello inferiore	screw	vis		
9	207417-0-01	1	vite	screw	vis		
10	207653-0-01	1	staffa	bracket	bride		
11	744334-2-00	1	vite	screw	vis		
12	206574-2-01	1	manov.alb.sup.con vite	crank for upper knife shaft	arbre couteau sup.avec vis		
13	705030-0-00	1	rondella	washer	rondelle		
14	741520-0-00	1	vite	screw	vis		
15	205024-0-62	1	salva ago	rear needle guard	portège-aiguille		
16	742758-0-00	1	vite	screw	vis		
17	206758-0-00	1	puntalino	pin	pivot		
18	202128-0-10	1	molla	spring	ressort		
19	206757-0-00	1	bussolina	bush	bague		
20	204687-0-11	1	perno	pin	pivot		
21	722471-2-00	1	vite	screw	vis		
22	704406-0-00	1	rondella	washer	rondelle		
23	202129-0-10	1	bussola	bush	bague		

Fig. N. Abb. N.	Part. N. Piece N. Bestell N. Pieza N.	Qt. Anzahl	DESCRIZIONE	DESCRIPTION	DESCRIPTION	BENENNUNG	DESCRIPCION
●	207972-4-01	1	coperchio distrib. olio compl.	cover assembly	couvercle complet		
1	207917-0-00	4	vite fissa bacinella	screw	vis		
2	207909-0-00	1	guarnizione bacinella	gasket	garniture		
3	206567-0-01	1	lamiera forata superiore	upper sheet	plaque perforée sup.		
4	206566-0-00	1	filtro	filter	filtre		
5	206565-0-01	1	lamiera forata inferiore	lower sheet	plaque perforée inf.		
6	207901-0-01	1	bacinella	oil sump	réservoir		
7	748086-2-00	1	vite fissa bacinella	screw	vis		
8	705977-0-00	1	rondella	washer	rondelle		
9	206564-0-00	1	tappo	plug	bouchon		
10	721484-2-00	1	vite	screw	vis		
11	990335-0-10	1	distanziale	spacer	entretoise		
12	206568-0-01	1	tubetto	pipe	tube		
13	206569-0-01	1	filtro	filter	filtre		
14	206667-0-00	1	tappo decompressione	plug	bouchon		
15	207975-0-00	1	astina indicat. liv. olio	stick	jauge niveau huile		
16	206665-2-00	1	galleggiante completo	float assembly	flotteur complet		
17	701005-0-00	1	anello di tenuta	retainer ring	bague d'étanchéité		
18	206558-0-01	1	tubo aspirante	pipe	tube		
19	701031-0-00	1	anello di tenuta	retainer ring	bague d'étanchéité		
20	729022-2-00	1	vite	screw	vis		
21	208087-3-00	1	indicatore livello olio	oil level gauge	indicateur niveau huile		
22	741535-0-00	2	vite	screw	vis		
23	746007-2-00	1	dado	nut	écrou		
24	207979-0-00	1	piastrina	plate	plaque		
25	701002-0-00	1	anello di tenuta	retainer ring	bague d'étanchéité		
26	207978-0-00	1	pistoncino	piston	piston		
27	207970-2-01	1	coperchio con tappo	cover with plug	couvercle with bouchon		
28	301586-0-10	2	tappo	plug	bouchon		
29	206662-0-00	1	spina	pin	goupille		
30	701151-0-00	1	anello di tenuta	retainer ring	bague d'étanchéité		
31	720411-2-00	1	vite	screw	vis		
32	206545-0-00	1	spirale per coperchio	spiral for cover	spirale pour couvercle		
33	701051-0-00	1	guarnizione	gasket	garniture		
34	206559-0-01	1	filtro	filter	filtre		
35	206560-0-20	1	coperchio	cover	couvercle		
36	722063-2-00	6	vite	screw	vis		
37	206557-0-00	1	chiavetta	key	clavette		
38	701004-0-00	1	anello di tenuta	retainer ring	bague d'étanchéité		
39	721494-2-00	2	vite	screw	vis		
40	207973-0-01	1	cupolina	cup	coupoie		
41	705970-0-00	1	guarnizione	gasket	garniture		
42	207971-0-00	1	ugello	nozzle	gicleur		
43	207977-0-00	1	bussolina	bush	bague		
44	701106-0-00	1	anello di tenuta	retainer ring	bague d'étanchéité		
45	733507-0-00	1	dado	nut	écrou		
46	206555-0-01	1	ruota	wheel	roue		
47	704813-0-00	1	rondella	washer	rondelle		
48	206554-0-02	1	coperchio	cover	couvercle		
49	722511-2-00	2	vite	screw	vis		
50	991218-0-00	1	sottobacinella	underban	sous-réservoir		
51	704345-2-00	4	rondella	washer	rondelle		
52	733008-2-00	4	dado	nut	écrou		

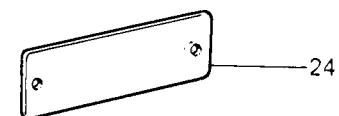
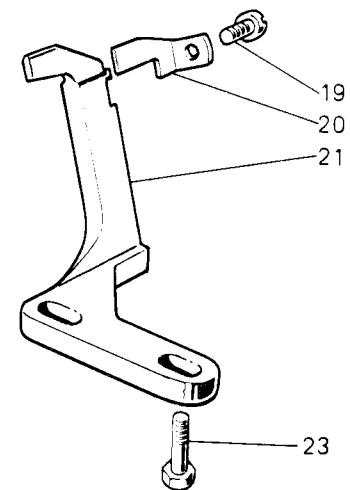
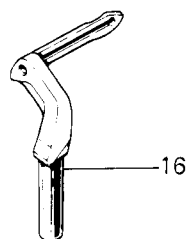
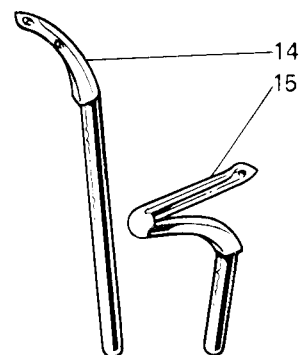
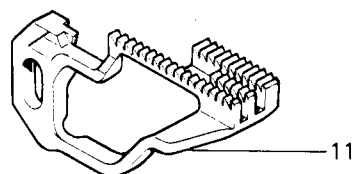
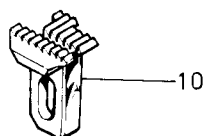
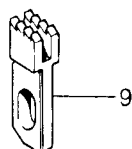
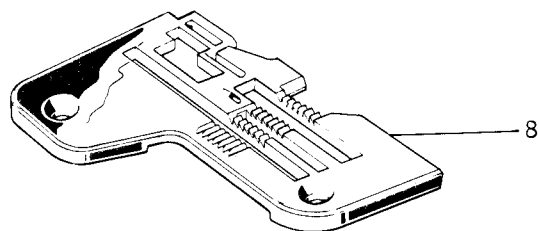
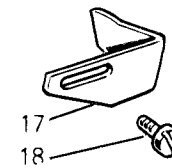
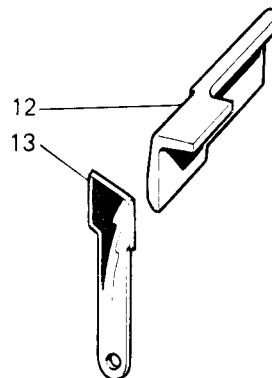
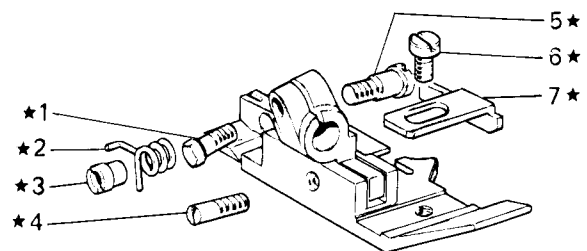

Fig. N. Abb. N.	Part. N. Piece N. Bestell N. Pieza N.	Qt. Anzahl	DESCRIZIONE	DESCRIPTION	DESCRIPTION	BENENNUNG	DESCRIPCION
★	205070-3-62	1	piedino completo	presserfoot assembly		pied-presseur complet	
1	204947-0-10	1	vite	screw		vis	
2	204894-0-11	1	molla	spring		ressort	
3	204895-0-11	1	bussola filettata	bush		bague	
4	204869-0-11	1	spina filettata	pin		goupille	
5	204889-0-10	1	vite	screw		vis	
6	741413-2-00	1	vite	screw		vis	
7	204878-0-11	1	piastrina	plate		plaque	
8	205025-0-62	1	placca ago larg. costa 5,5 mm.	needle plate width bight 5,5 mm		plaque à aiguille largeur surjet 5,5 mm.	
9	202609-0-60	1	griffino	feed dog		petite griffe	
10	205011-0-60	1	griffa sussidiaria	subsidiary feed dog		griffe subsidiaire	
11	205007-0-62	1	griffa principale	main feed dog		griffe principale	
12	207003-2-60	1	coltello superiore	upper knife		couteau supérieur	
13	207020-2-61	1	coltello inferiore	lower knife		couteau inférieur	
14	206512-0-62	1	crochet superiore	upper looper		crochet supérieur	
15	202413-0-62	1	crochet inferiore	lower looper		crochet inférieur	
16	207722-0-61	1	crochet punto sicurezza	safety stitch looper		crochet point de sûreté	
17	204905-0-10	1	squadretta	bracket		équerre	
18	721443-2-00	1	vite	screw		vis	
19	741431-0-00	1	vite	screw		vis	
20	204863-0-61	1	salva ago	rear needle guard		protège-aiguille	
21	204861-0-60	1	spingi asola	front needle guard		pare-boucle	
23	740230-2-00	2	vite	screw		vis	
24	780501-0-00	1	targhetta classe testa	head class plate		plaque classe tête	

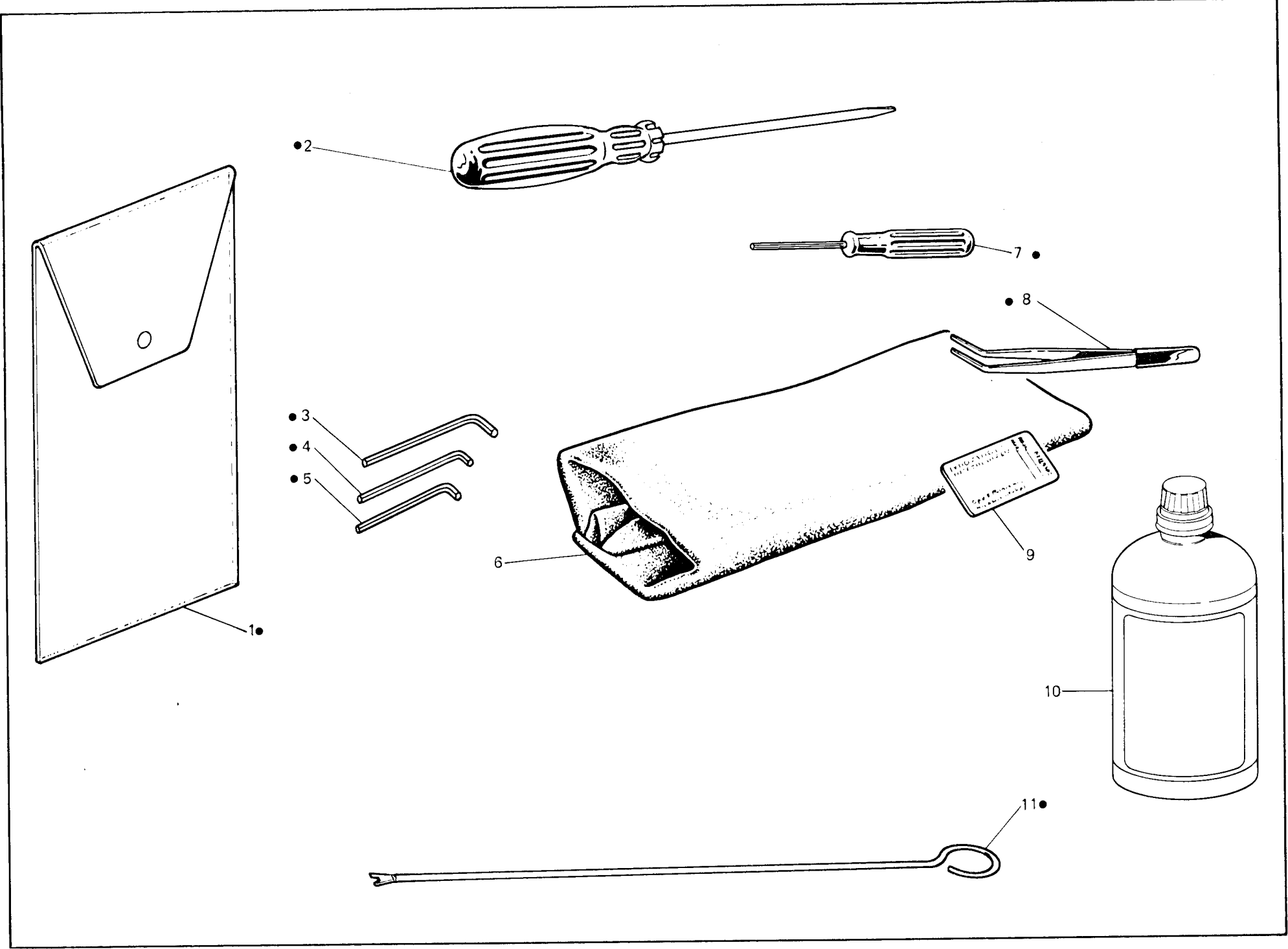

Fig. N. Abb. N.	Part. N. Piecce N. Bestell N. Pieza N.	Qt. Anzahl	DESCRIZIONE	DESCRIPTION	DESCRIPTION
●	991400-4-02	1	busta accessori completa	accessories envelope assembly	enveloppe accessoires complète
1	991415-0-00	1	busta accessori	accessories envelope	enveloppe accessoires
2	990723-0-00	1	cacciavite medio	screw driver	tournevis moyen
3	990639-0-10	1	chiave esag. da 3 mm	3 mm hexagonal key	clé hexagonale de 3 mm
4	990685-0-10	1	chiave esag. da 2,5 mm	2,5 mm hexagonal key	clé hexagonale de 2,5 mm
5	990325-0-10	1	chiave esag. da 2 mm	2 mm hexagonal key	clé hexagonale de 2 mm
6	990918-0-00	1	cuffia protezione testa	machine cover	couverture protection tête
7	990474-0-11	1	chiave esag. da 1,5 mm	1,5 mm hexagonal key	clé hexagonale de 1,5 mm
8	990176-0-10	1	pinzà per infilatura	threading clers	pince pour enfilage
9	★	1	bustina aghi	needles packet	paquette aiguilles
10	991280-0-10	1	lattina olio	oil container	bidon de huile
11	990577-0-10	1	astina per infilatura	threading rod	tige pour enfilage
			★ per l'ordinazione della bustina citare lo stesso simbolo dell'ago montato sulla testa	★ to order packet of needles pleasi specify symbol of needle fitted on machine	★ pour commander un sachet d'aiguille donner le symbol de l'aiguille montée sur la tête

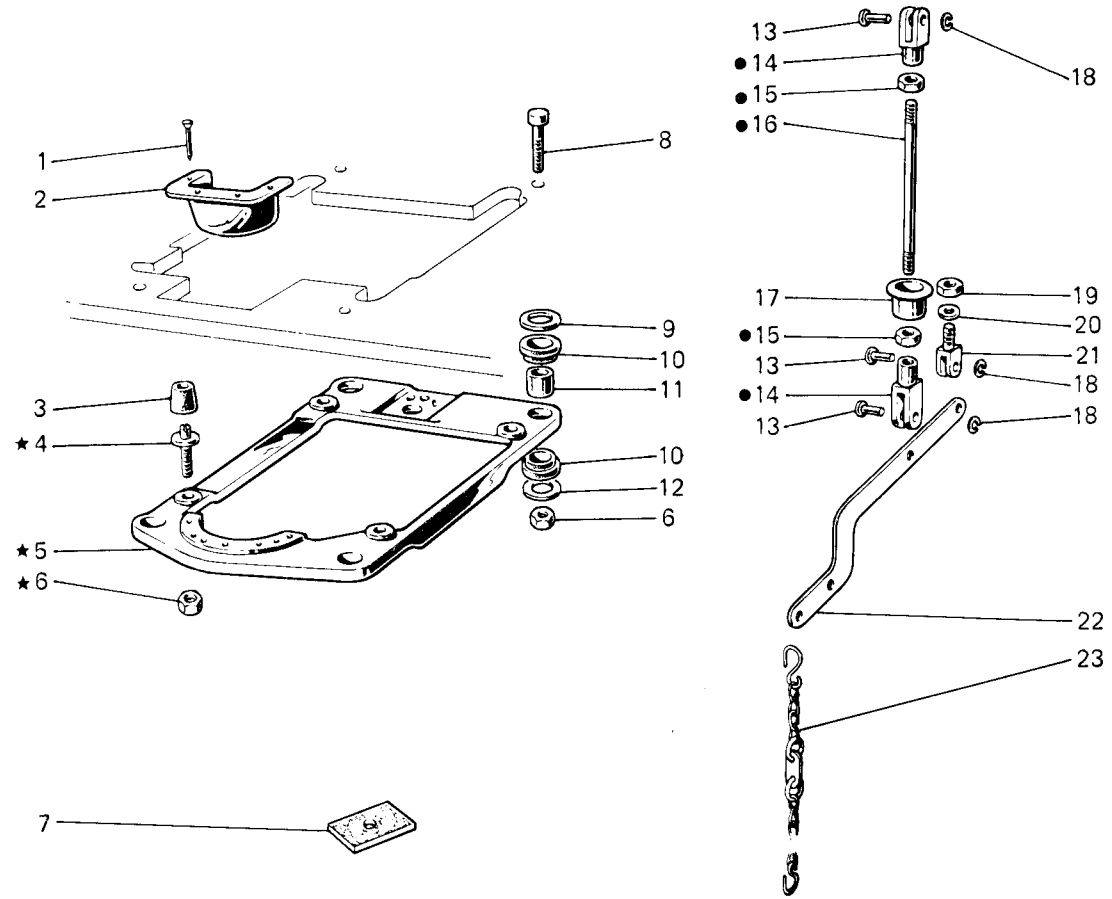

Fig. N. Abb. N.	Part. N. Piece N. Bestell N. Pieza N.	Qt. Anzahl	DESCRIZIONE	DESCRIPTION	DESCRIPTION
★	990987-4-00	1	supporto testa completo	head support assembly	support tête complet
●	990984-4-10	1	tirante alza piedino completo	presser tie-rod assembly	tirant pour soulèv. pied-presseur
1	900201-0-10	4	chiodino	rivet	clou
2	991187-0-01	1	bocchetta	cup	bouche
3	990982-0-00	4	ammortizzatore	shock absorber	amortisseur
4	900694-0-11	4	perno	pin	pivot
5	990981-0-00	1	supporto testa	head support	support tête
6	733008-2-00	8	dado	nut	écrou
7	900203-0-10	4	ammortizzatori per tavola	shock absorber	amortisseur
8	722905-2-00	4	vite	screw	vis
9	704346-2-00	4	rondella	washer	rondelle
10	901101-0-00	8	ammortizzatore	shock absorber	amortisseur
11	901102-0-00	4	distanziale	spacer	entretoise
12	704345-2-00	4	rondella	washer	rondelle
13	990311-0-10	3	perno	pin	pivot
14	990310-0-10	2	giunto	joint	joint
15	746402-2-00	2	dado	nut	écrou
16	990452-0-00	1	tirante	tie-rod	tirant
17	900204-0-10	1	bussola	bush	bague
18	700205-0-00	3	anello elastico	spring ring	anneau ressort
19	746409-2-00	1	dado	nut	écrou
20	704424-2-00	1	rondella	washer	rondelle
21	990314-0-10	1	supportino	support	support
22	990316-0-11	1	leva	lever	levier
23	990179-4-11	1	catenella completa	chain assembly	chaînette complète

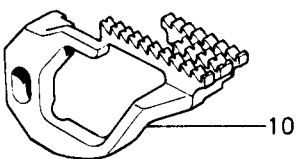
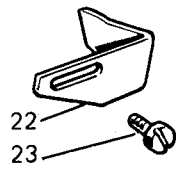
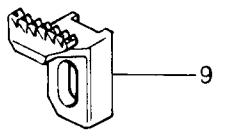
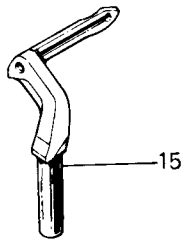
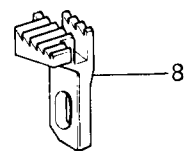
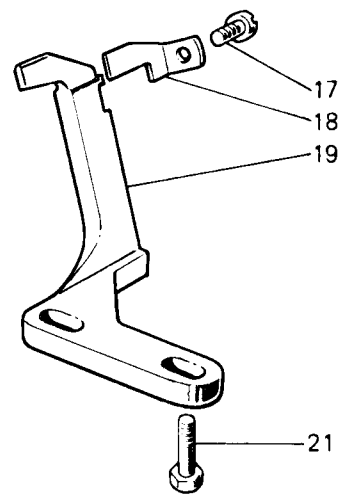
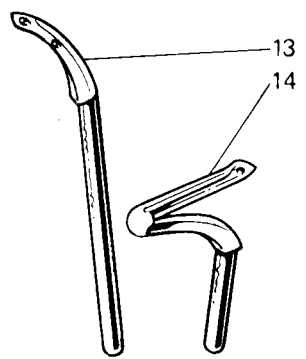
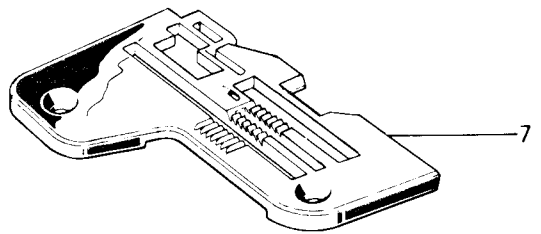
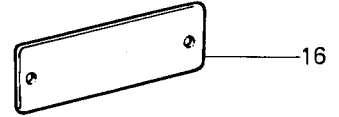
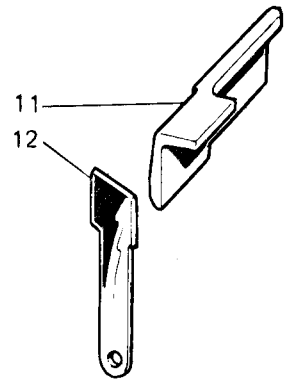
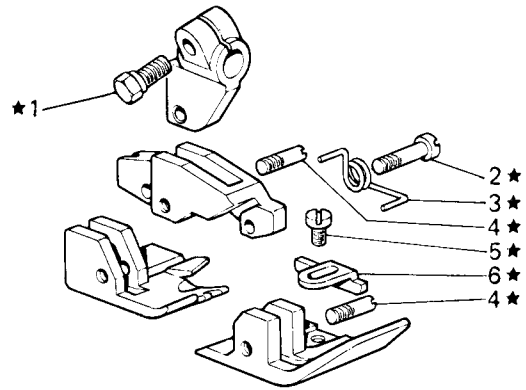

Fig. N. Abb. N.	Part. N. Piecce N. Bestell N. Pieza N.	Qt. Anzahl	DESCRIZIONE	DESCRIPTION	DESCRIPTION
★	207133-3-63	1	pedino completo	presserfoot assembly	piéd-presseur complet
1	204947-0-10	1	vite	screw	vis
2	207584-0-00	1	vite	screw	vis
3	207585-0-00	1	molla	spring	ressort
4	207554-0-00	2	vite	screw	vis
5	741413-2-00	1	vite	screw	vis
6	206982-0-01	1	guida	guide	guide
7	207646-0-60	1	placca ago larg. costa 5 mm	needle plate width bight 5 mm	plaque à aiguille largeur surjet 5 mm
8	207642-0-60	1	griffa sussidiaria	subsidiary feed dog	griffe subsidiaire
9	207641-0-60	1	griffa sussidiaria	subsidiary feed dog	griffe subsidiaire
10	207581-0-61	1	griffa principale	main feed dog	griffe principale
11	207003-2-60	1	coltello superiore	upper knife	couteau supérieur
12	207651-0-60	1	coltello inferiore	lower knife	couteau inférieur
13	206512-0-62	1	crochet superiore	upper looper	crochet supérieur
14	202413-0-62	1	crochet inferiore	lower looper	crochet inférieur
15	207722-0-61	1	crochet punto sicurezza	safety stitch looper	crochet point de sûreté
16	780501-0-00	1	targhetta classe testa	head class plate	plaque classe tête
17	741431-0-00	1	vite	screw	vis
18	204863-0-61	1	salva ago	rear needle guard	protège-aiguille
19	204861-0-60	1	spingi asola	front needle guard	pare-boucle
21	740230-2-00	2	vite	screw	vis
22	204905-0-10	1	squadretta	bracket	équerre
23	721443-2-00	1	vite	screw	vis
38	<u>Tav. 4</u> 206093-3-00	1	passafilo snodato	thread guide	passe-fil
20	<u>Tav. 8</u> 207684-3-01	1	biellino	con-rod	petite bielle
37	<u>Tav. 9</u> 765515-6-12	2	ago RIM 29A fin. 120	needle RIM 29A size 120	aiguille RIM 29A jauge 120
■	<u>Tav. 10</u> 207887-4-00	1	leva premistoffa con perno	lever	levier
15	206808-0-01	1	leva	lever	levier
16	206985-0-00	1	molla premi pedino	spring	ressort
41	990694-0-01	1	salvadita	protection	protection
15	<u>Tav. 11</u> 207725-0-60	1	salva ago	rear needle guard	protège-aiguille