

Rimoldi[®]

CATALOGO PEZZI DI RICAMBIO **Rim**[®]

Rim[®] SPARE PARTS CATALOGUE

CATALOGUE RECHANGES **Rim**[®]

194-ZA PER TESTE
FOR HEADS
POUR TETES

261-16-2MD-04
261-34-2DR-25
261-34-2DR-26
261-34-2DR-43
261-34-2WR-25
261-34-2WR-26
261-34-2WR-43
261-34-3DR-18

263-16-2MD-01
263-16-2MD-10
263-34-2DR-20
263-34-2DR-22
263-34-2DR-27
263-34-2WR-20
263-34-2WR-22
263-34-2WR-27
263-16-3MD-04
263-34-3DR-16
263-34-3DR-30

194-ZB PER TESTE
FOR HEADS
POUR TETES

261-16-2MD-04

263-16-2MD-01
263-16-2MD-10
263-16-3MD-04

194-ZC PER TESTE
FOR HEADS
POUR TETES

261-34-2DR-25
261-34-2DR-26
261-34-2DR-43
261-34-2WR-25
261-34-2WR-26
261-34-2WR-43
261-34-3DR-18

263-34-2DR-20
263-34-2DR-22
263-34-2DR-27
263-34-2WR-20
263-34-2WR-22
263-34-2WR-27
263-34-3DR-16
263-34-3DR-30

194-ZD PER TESTE
FOR HEADS
POUR TETES

261-34-2DR-25
261-34-2DR-26
261-34-2DR-43
261-34-2WR-25
261-34-2WR-26
261-34-2WR-43
261-34-3DR-18

263-34-2DR-20
263-34-2DR-22
263-34-2DR-27
263-34-2WR-20
263-34-2WR-22
263-34-2WR-27
263-34-3DR-16
263-34-3DR-30

194-ZA
194-ZB
194-ZC
194-ZD

GUIDA PER LA CONSULTAZIONE DEL CATALOGO RICAMBI

Tutti i particolari che compongono i dispositivi e le varianti, in funzione delle teste sulle quali vengono montati, sono rappresentati in più tavole come indicato nell'indice.

Ogni tavola riporta i componenti impiegati solo per i dispositivi elencati.

Nelle tavole i particolari vengono riquadrati nei seguenti casi:

- 1) Quando compongono un gruppo
- 2) Quando compongono un sottogruppo
- 3) Quando sono impiegati solo per i dispositivi elencati nel riquadro.

Un particolare o un gruppo viene richiamato con una lettera nei seguenti casi:

- 1) Quando non sono comuni a tutte le teste sulle quali vengono montati i dispositivi
- 2) Quando non sono comuni a tutti i dispositivi riportati nel catalogo
- 3) Quando esistono alternative del medesimo particolare o gruppo.

Per la loro consultazione, rimandiamo alle relative tabelle delle varianti pubblicate nella stessa tavola oppure nelle ultime pagine del catalogo.

Gli organi di cucitura, le guide e gli accessori sono preceduti da tavole riepilogative con l'indicazione dei particolari in dotazione e di quelli a richiesta.

Per ordini di aghi, precisare il simbolo riportato in catalogo; in caso di dubbio allegare un ago campione o una bustina vuota.

GUIDELINES FOR THE USE OF THE SPARE PARTS CATALOGUE

All the parts that are components of devices and the variants are represented in more tables as shown in the index, in relation to the head they are mounted on. Each table indicates the components relevant only to the listed devices.

Some symbols are represented within a square in the following cases:

- 1) When they are part of an assembly
- 2) When they are part of a sub-assembly
- 3) When they are used only for the devices listed in a square.

A letter refers to a part or to an assembly in the following cases:

- 1) When they are not common to all heads the devices are mounted on
- 2) When they are not common to all devices shown in the catalogue
- 3) When there are alternatives to the same part or assembly.

In this case, refer to the relative charts of variables published in the same table or in the last pages of the catalogue.

The sewing parts, guides, folders and accessories are preceded by summary tables indicating standard parts and parts supplied on request.

When ordering needles, please specify catalogue symbol; if you have doubts, send a sample needle or an empty needle bag with your order.

GUIDE A LA CONSULTATION DU CATALOGUE PIÈCES DE RECHANGE

Toutes les pièces qui composent les dispositifs et les variantes, en fonction des têtes sur lesquelles elles sont montées, ont été représentées sur plusieurs tables comme indiqué en index.

Chaque table porte les composants employés uniquement pour les dispositifs énoncés.

Sur les tables les composants sont bordés dans les suivants cas:

- 1) Quand ils composent un groupe
- 2) Quand ils composent un sous-groupe
- 3) Quand ils sont employés uniquement pour les dispositifs énoncés en bordure (en marge).

Un composant ou un groupe est rappelé avec une lettre dans les cas suivants:

- 1) Quand il n'est pas commun à toutes les têtes sur lesquelles on monte les dispositifs
- 2) Quand il n'est pas commun à tous les dispositifs énoncés sur le catalogue
- 3) Quand il existe des alternatives du même composant ou groupe.

Pour leur consultation, se référer aux relatives fiches des variantes publiées sur la table même ou dans les dernières pages du catalogue.

Les éléments de couture, les guides et les accessoires sont précédés de tables de récapitulations avec l'index des composants en dotation et ceux sur demande.

Pour les commandes d'aiguilles, préciser le symbole indiqué sur le catalogue, en cas de doute joindre une aiguille échantillon ou un sachet vide.

ANLEITUNG FÜR DIE BENUTZUNG DES ERSATZTEIKATALOGES

Alle Teile welche die Vorrichtungen und die Varianten bilden sind, in Anbetracht auf die Oberteile auf welche sie angebaut werden, in mehreren Tafeln dargestellt, wie im Inhaltsverzeichnis angegeben.

Jede Tafel führt nur die Teile für die angegebene Vorrichtung auf.

In den Tafeln werden die Teile in folgenden Fällen umrahmt:

- 1) Wenn sie eine Teilegruppe bilden
- 2) Wenn sie eine Untergruppe bilden
- 3) Wenn sie nur für die in der Umrahmung angeführten Vorrichtungen benutzt werden.

Ein Teil oder eine Teilegruppe wird in folgenden Fällen mit einem Buchstaben gekennzeichnet:

- 1) Wenn das Teil oder die Gruppe nicht gleich ist für den Anbau an alle Oberteile an welche die Vorrichtungen angebaut werden
- 2) Wenn das Teil oder die Gruppe nicht für alle im Katalog angeführten Vorrichtungen gemein ist
- 3) Wenn für dasselbe Teil oder dieselbe Teilegruppe Alternativen bestehen

Für deren zu Rateziehung verweisen wir auf die auf derselben Tafel angeführten Tabellen der Varianten oder auf die letzten Seiten des Kataloges.

Vor den Tafeln mit den Nähwerkzeugen, Führungen und Ausstattungen befinden sich zusammenfassende Tafeln mit Angabe der in Normalausstattung und der auf Anfrage lieferbaren Teile.

Für Aufträge über Nähadeln ist die im Ersatzteilkatalog angeführte Teilenummer anzugeben; in Zweifelsfällen ist eine Nadel als Muster oder ein entsprechender leerer Nadelbrief beizulegen.

GUIA PARA LA CONSULTA DEL CATALOGO DE REPUESTOS

Todos los particulares que componen los dispositivos y las variantes, en función de los cabezales sobre los cuales vienen montados, son representados en más mesas como indicado en el índice.

En cada mesa figuran los componentes empleados solo para los dispositivos relacionados.

En las mesas y particulares vienen encuadrados en los siguientes casos:

- 1) Cuando componen un grupo
- 2) Cuando componen un subgrupo
- 3) Cuando son empleados solo para los dispositivos relacionados en el recuadro.

Un particular o un grupo viene llamado con una letra en los siguientes casos:

- 1) Cuando no son comunes a todos los cabezales sobre los cuales vienen montados los dispositivos
- 2) Cuando no son comunes a todos los dispositivos que figuran en el catalogo
- 3) Cuando existen alternativas del mismo particular o grupo

Para su consulta ver las relativas tablas de las variantes publicadas en la misma mesa o bien en las últimas páginas del catalogo.

Los órganos de costura, las guías y los accesorios son precedidos de un resumen de mesas con la indicación de particulares en dotación y de los solicitados.

Por pedido de agujas, precisar el símbolo que figura en el catalogo, en caso de duda adjuntar una aguja modelo o un sobre vacío.

Rim® TAV. 1

Fig. N.	Part. N. Piece N.	Qt.
1	800070-4-00	1
2	722411-2-00	1
3	931843-2-00	1
4	722451-2-00	1
5	722422-2-00	2
6	726403-4-00	1
7	726401-4-00	4
8	800088-4-00	1
9	800073-0-00	2

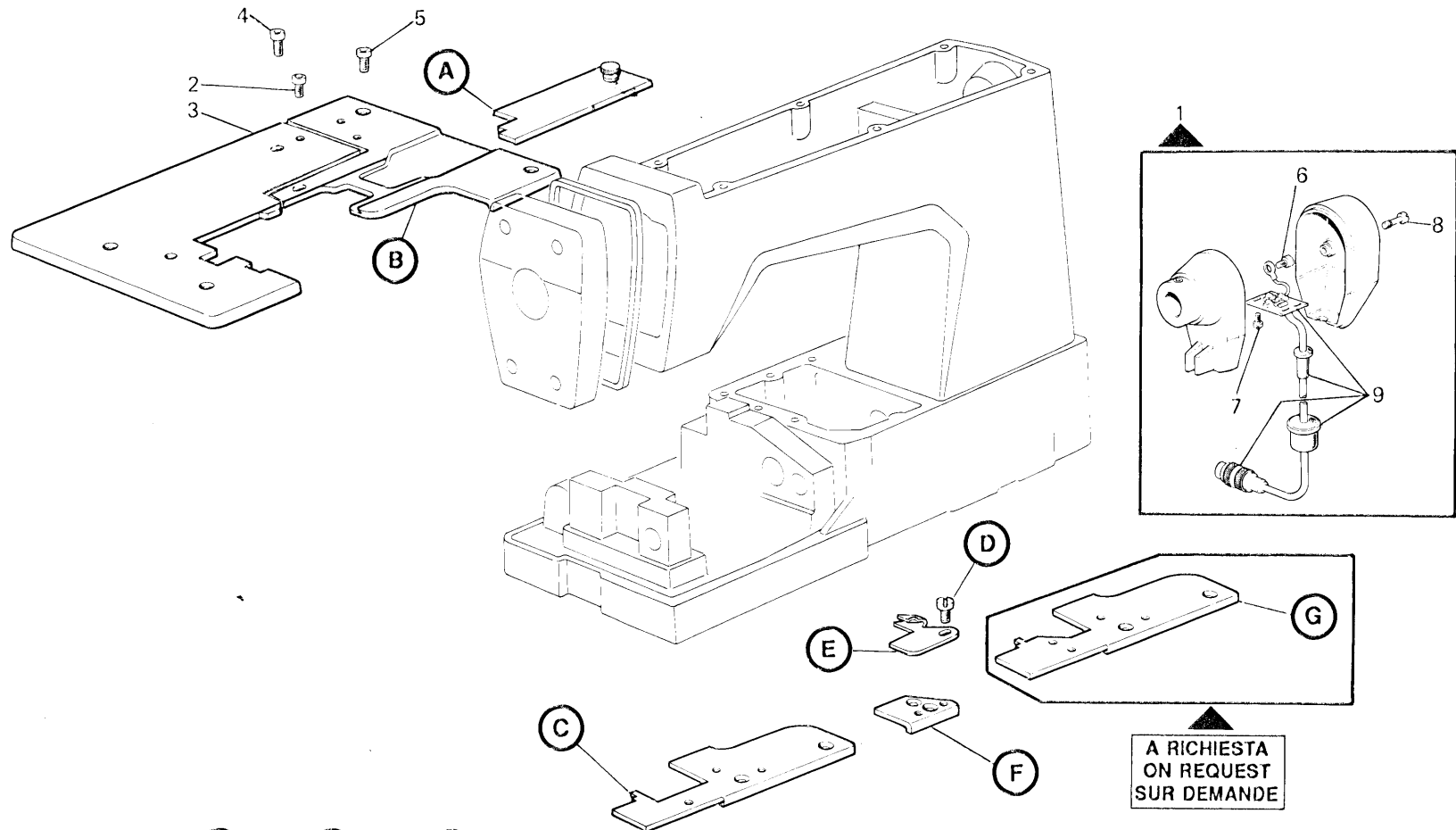

(A) (B) (C) (D) (E) (F) (G)

261-16-2MD-04	931840-2-00	931845-0-00	—	741658-2-00	929947-2-00	929825-0-10	—
261-34-2DR-25	931841-2-00	931844-0-00	929826-0-10	—	—	—	—
261-34-2DR-26	931841-2-00	931844-0-00	929826-0-10	—	—	—	—
261-34-2DR-43	931841-2-00	931844-0-00	929826-0-10	—	—	—	—
261-34-2WR-25	931841-2-00	931844-0-00	929826-0-10	—	—	—	—
261-34-2WR-26	931841-2-00	931844-0-00	929826-0-10	—	—	—	—
261-34-2WR-43	931841-2-00	931844-0-00	929826-0-10	—	—	—	—
261-34-3DR-18	931841-2-00	931844-0-00	929826-0-10	—	—	—	—
263-16-2MD-01	931840-2-00	931845-0-00	—	741658-2-00	929947-2-00	929825-0-10	—
263-16-2MD-10	931840-2-00	931845-0-00	—	—	—	929825-0-10	—
263-34-2DR-20	931841-2-00	931844-0-00	929826-0-10	—	—	—	929827-0-10
263-34-2DR-22	931841-2-00	931844-0-00	929826-0-10	—	—	—	—
263-34-2DR-27	931841-2-00	931844-0-00	929826-0-10	—	—	—	—
263-34-2WR-20	931841-2-00	931844-0-00	929826-0-10	—	—	—	929827-0-10
263-34-2WR-22	931841-2-00	931844-0-00	929826-0-10	—	—	—	—
263-34-2WR-27	931841-2-00	931844-0-00	929826-0-10	—	—	—	—
263-16-3MD-04	931840-2-00	931845-0-00	—	741658-2-00	929947-2-00	929825-0-10	—
263-34-3DR-16	931841-2-00	931844-0-00	929826-0-10	—	—	—	—
263-34-3DR-30	931841-2-00	931844-0-00	929826-0-10	—	—	—	—

	(A)	(B)	(C)	(D)	(E)	(F)	(G)	(H)	(L)	(M)	(N)	(O)	(P)
261-16-2MD-04	—	704409-2-00	703007-0-00	733507-2-00	944795-0-00	—	—	—	—	741974-2-00	302247-0-10	924235-0-01	924236-4-01
261-34-2DR-25	929303-0-00	704220-2-00	703007-0-00	733507-2-00	944950-0-00	206893-0-00	202352-2-11	703008-0-00	741153-0-00	—	—	—	—
261-34-2DR-26	929303-0-00	704220-2-00	703007-0-00	733507-2-00	944950-0-00	206893-0-00	202352-2-11	703008-0-00	741153-0-00	—	—	—	—
261-34-2DR-43	929303-0-00	704220-2-00	703007-0-00	733507-2-00	944950-0-00	206893-0-00	202352-2-11	703008-0-00	741153-0-00	—	—	—	—
261-34-2WR-25	—	704409-2-00	703007-0-00	733507-2-00	944795-0-00	—	—	—	—	—	—	—	—
261-34-2WR-26	—	704409-2-00	703007-0-00	733507-2-00	944795-0-00	—	—	—	—	—	—	—	—
261-34-2WR-43	—	704409-2-00	703007-0-00	733507-2-00	944795-0-00	—	—	—	—	—	—	—	—
261-34-3DR-18	929303-0-00	704220-2-00	703007-0-00	733507-2-00	944950-0-00	206893-0-00	202352-2-11	703008-0-00	741153-0-00	741974-2-00	302247-0-10	924235-0-01	924236-4-01
263-16-2MD-01	—	704409-2-00	703007-0-00	733507-2-00	944795-0-00	—	—	—	—	741974-2-00	302247-0-10	924235-0-01	924236-4-01
263-16-2MD-10	—	704409-2-00	703007-0-00	733507-2-00	944795-0-00	—	—	—	—	741974-2-00	302247-0-10	924235-0-01	924236-4-01
263-34-2DR-20	929303-0-00	704220-2-00	703007-0-00	733507-2-00	944950-0-00	206893-0-00	202352-2-11	703008-0-00	741153-0-00	—	—	—	—
263-34-2DR-22	929303-0-00	704220-2-00	703007-0-00	733507-2-00	944950-0-00	206893-0-00	202352-2-11	703008-0-00	741153-0-00	—	—	—	—
263-34-2DR-27	929303-0-00	704220-2-00	703007-0-00	733507-2-00	944950-0-00	206893-0-00	202352-2-11	703008-0-00	741153-0-00	—	—	—	—
263-34-2WR-20	—	704409-2-00	703007-0-00	733507-2-00	944795-0-00	—	—	—	—	—	—	—	—
263-34-2WR-22	—	704409-2-00	703007-0-00	733507-2-00	944795-0-00	—	—	—	—	—	—	—	—
263-34-2WR-27	—	704409-2-00	703007-0-00	733507-2-00	944795-0-00	—	—	—	—	—	—	—	—
263-16-3MD-04	—	704409-2-00	703007-0-00	733507-2-00	944795-0-00	—	—	—	—	741974-2-00	302247-0-10	924235-0-01	924236-4-01
263-34-3DR-16	929303-0-00	704220-2-00	703007-0-00	733507-2-00	944950-0-00	206893-0-00	202352-2-11	703008-0-00	741153-0-00	—	—	—	—
263-34-3DR-30	929303-0-00	704220-2-00	703007-0-00	733507-2-00	944950-0-00	206893-0-00	202352-2-11	703008-0-00	741153-0-00	—	—	—	—

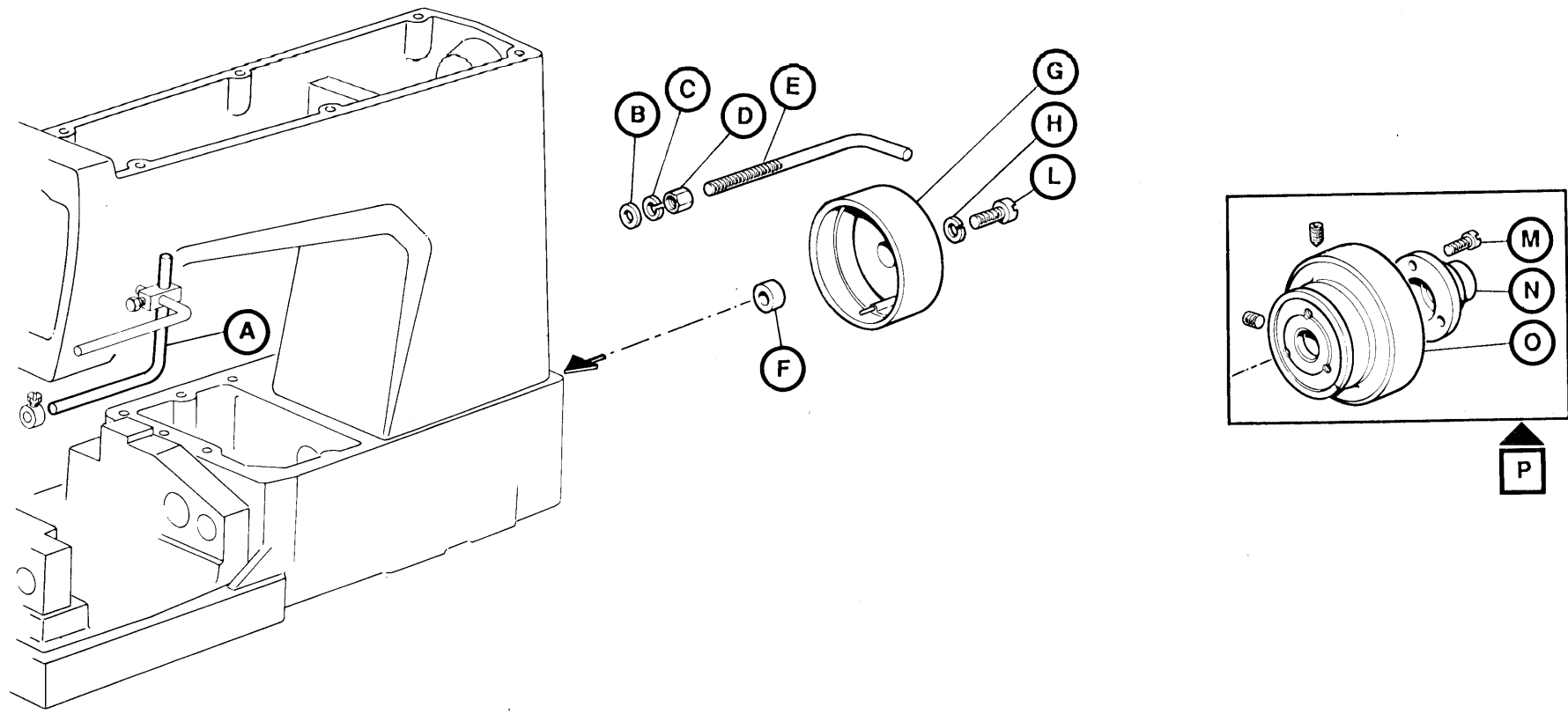

Rim[®] TAV. 3

Fig. N.	Part. N. Piece N.	Qt.
1	929751-4-00	1
2	309000-0-00	1
3	307754-0-00	1
4	740257-2-00	1
5	740243-2-00	1
6	300362-0-11	1
7	704805-0-00	2
8	300228-0-10	1
9	740475-2-00	1
10	308275-2-00	1
11	778414-0-00	2
12	746404-2-00	1
13	308196-0-10	1
14	729013-2-00	2
15	308191-4-01	1
16	308190-0-00	2
17	300361-0-20	1
18	300231-0-30	1
19	308276-0-20	1
20	202473-0-11	1
21	745815-2-00	1
22	309560-0-00	2
23	706434-0-00	2
24	311343-2-00	1
25	302333-0-10	2
26	741928-0-00	4
27	300371-0-11	2
28	929750-2-00	1
29	742811-0-00	1
30	721444-2-00	1
31	741538-2-00	2
32	929779-0-00	1
33	308030-2-00	1
34	301459-4-10	1
35	201143-0-10	2
36	301579-0-10	1
37	778238-0-00	1
38	300209-0-10	1
39	727215-0-00	2

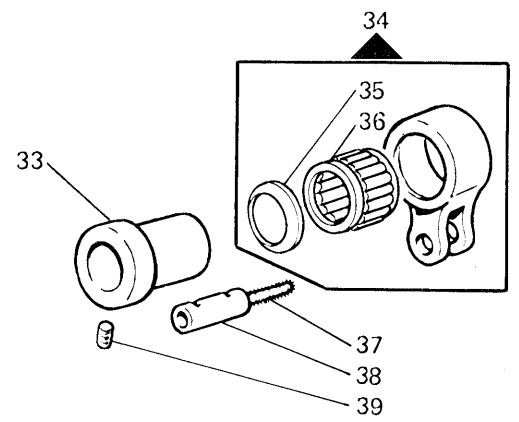
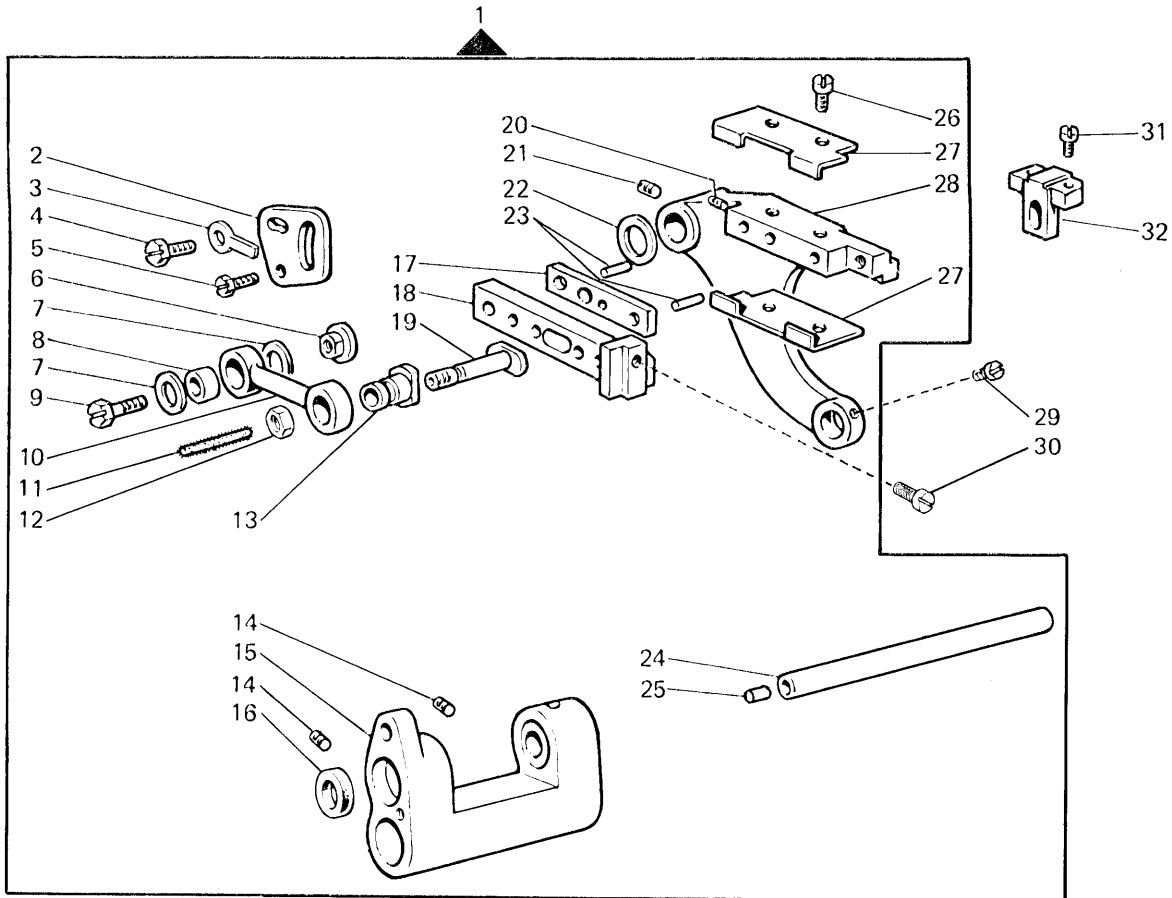

Rim® TAV. 4

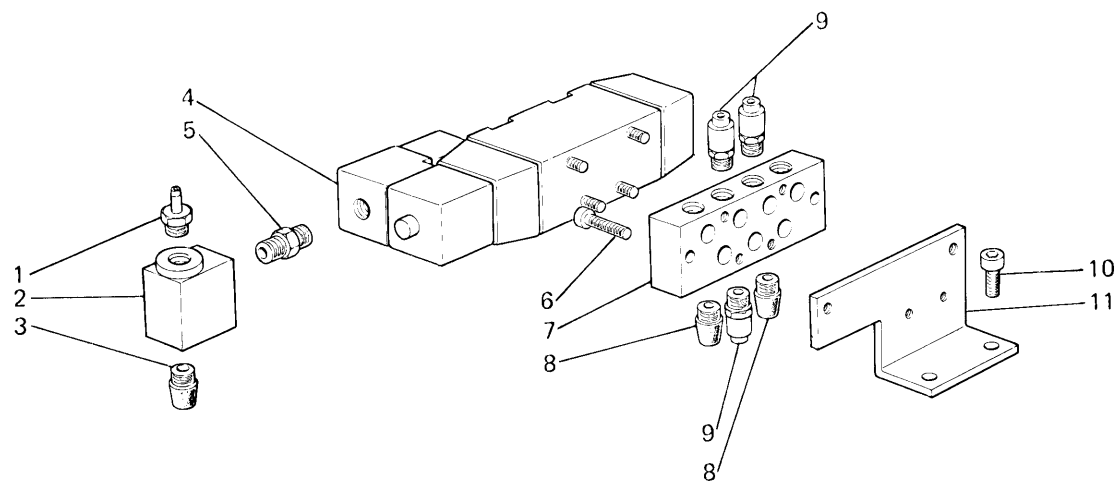
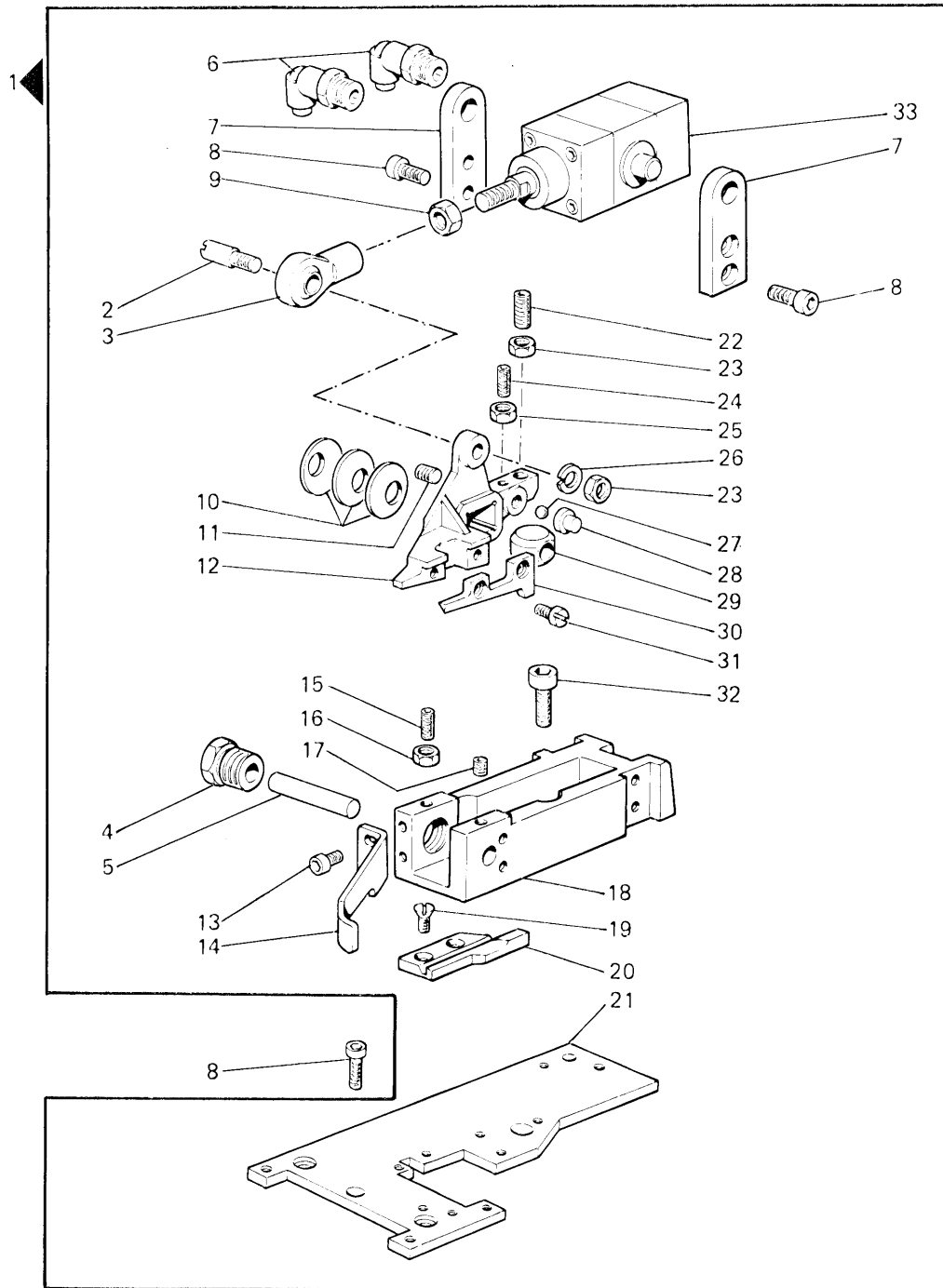
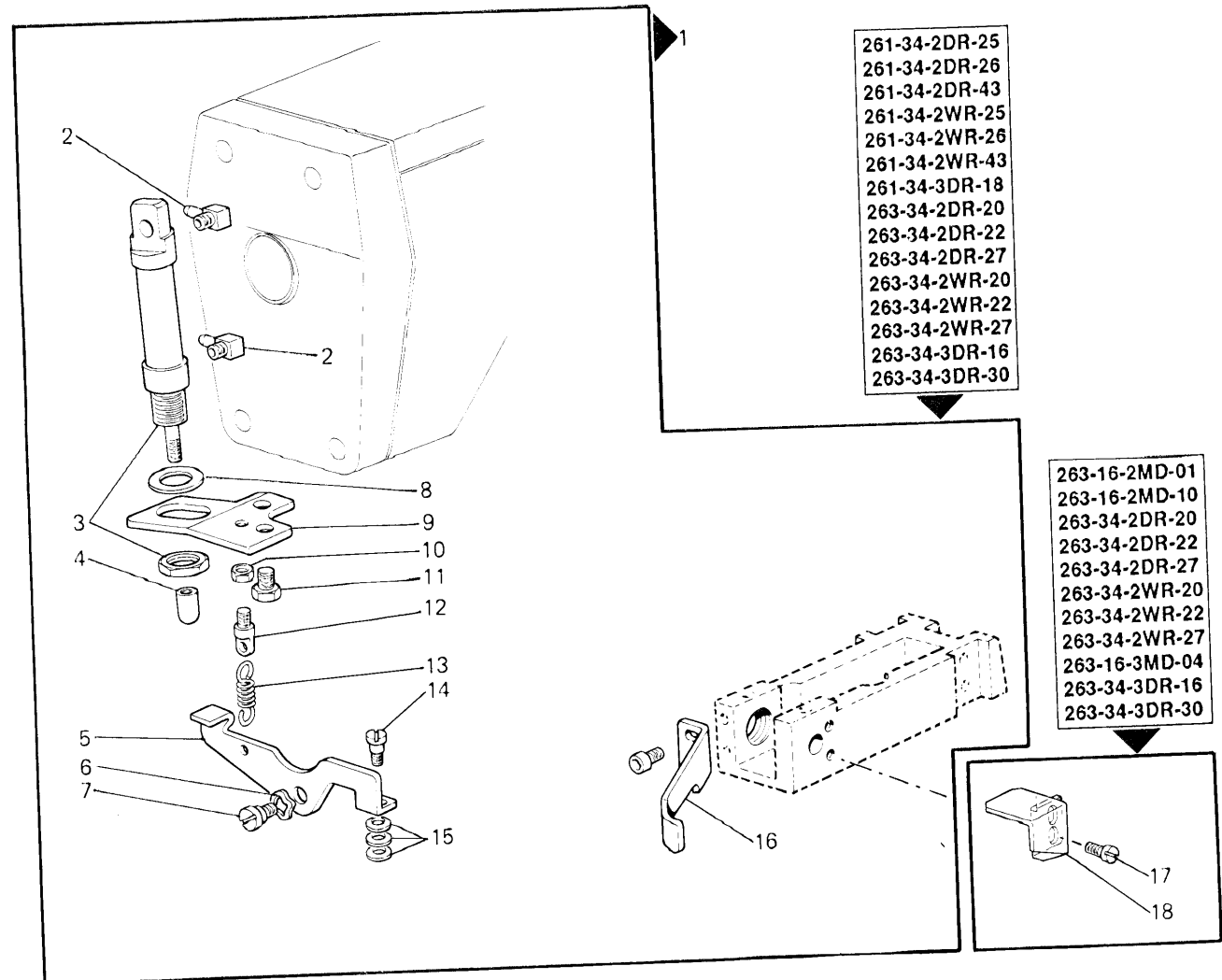

Fig. N.	Part. N. Piece N.	Qt.
1	924870-0-10	1
2	941419-0-00	1
3	924851-0-10	1
4	940469-4-02	1
5	940561-0-00	1
6	722452-2-00	2
7	929840-0-00	1
8	922754-0-00	2
9	941514-4-00	3
10	722431-2-00	2
11	931849-0-00	1

Rim® TAV. 5

Fig. N.	Part. N. Piece N.	Qt.
1	931848-4-00	1
2	929831-0-00	1
3	931769-0-00	1
4	929806-0-00	1
5	929808-0-00	1
6	941514-4-00	2
7	931773-0-00	2
8	722432-2-00	5
9	733006-2-00	1
10	702432-0-00	3
11	729033-2-00	1
12	929805-0-00	1
13	721424-2-00	2
14	929814-0-00	1
15	729052-2-00	1
16	733505-2-00	1
17	729032-5-00	1
18	931847-0-00	1
19	724422-5-00	2
20	929804-0-00	1
21	931846-2-00	1
22	729894-2-00	1
23	733508-2-00	2
24	729031-5-00	1
25	733503-2-00	1
26	703008-0-00	1
27	707603-0-00	1
28	929810-0-00	1
29	929809-0-00	1
30	929803-0-00	1
31	741936-5-00	2
32	722443-2-00	2
33	931770-4-00	1





- 261-34-2DR-25
- 261-34-2DR-26
- 261-34-2DR-43
- 261-34-2WR-25
- 261-34-2WR-26
- 261-34-2WR-43
- 261-34-3DR-18
- 263-34-2DR-20
- 263-34-2DR-22
- 263-34-2DR-27
- 263-34-2WR-20
- 263-34-2WR-22
- 263-34-2WR-27
- 263-34-3DR-16
- 263-34-3DR-30

- 263-16-2MD-01
- 263-16-2MD-10
- 263-34-2DR-20
- 263-34-2DR-22
- 263-34-2DR-27
- 263-34-2WR-20
- 263-34-2WR-22
- 263-34-2WR-27
- 263-16-3MD-04
- 263-34-3DR-16
- 263-34-3DR-30

Fig. N.	Part. N. Piece N.	Qt.
1	932315-4-00	1
2	943892-0-01	2
3	932314-0-00	1
4	932309-0-00	1
5	932306-0-00	1
6	307605-0-00	1
7	932307-0-00	1
8	704849-0-00	1
9	932305-0-00	1
10	733503-2-00	1
11	740051-2-00	2
12	206711-0-00	1
13	920746-0-00	1
14	932308-0-00	1
15	704102-2-00	3
16	932318-0-00	1
17	741936-2-00	2
18	929830-0-00	1

Rim® TAV. 7

Fig. N.	Part. N. Piece N.	Qt.
1	910215-4-10	1
2	910214-4-11	1
3	910217-2-00	1
4	733505-2-00	2
5	910190-0-10	2
6	746601-2-00	2
7	910216-0-10	1
8	700205-0-00	2
9	920765-0-00	2
10	910187-0-11	1
11	910213-0-10	1
12	721474-2-00	3
13	203211-0-10	2
14	990440-0-10	1
15	721484-2-00	2

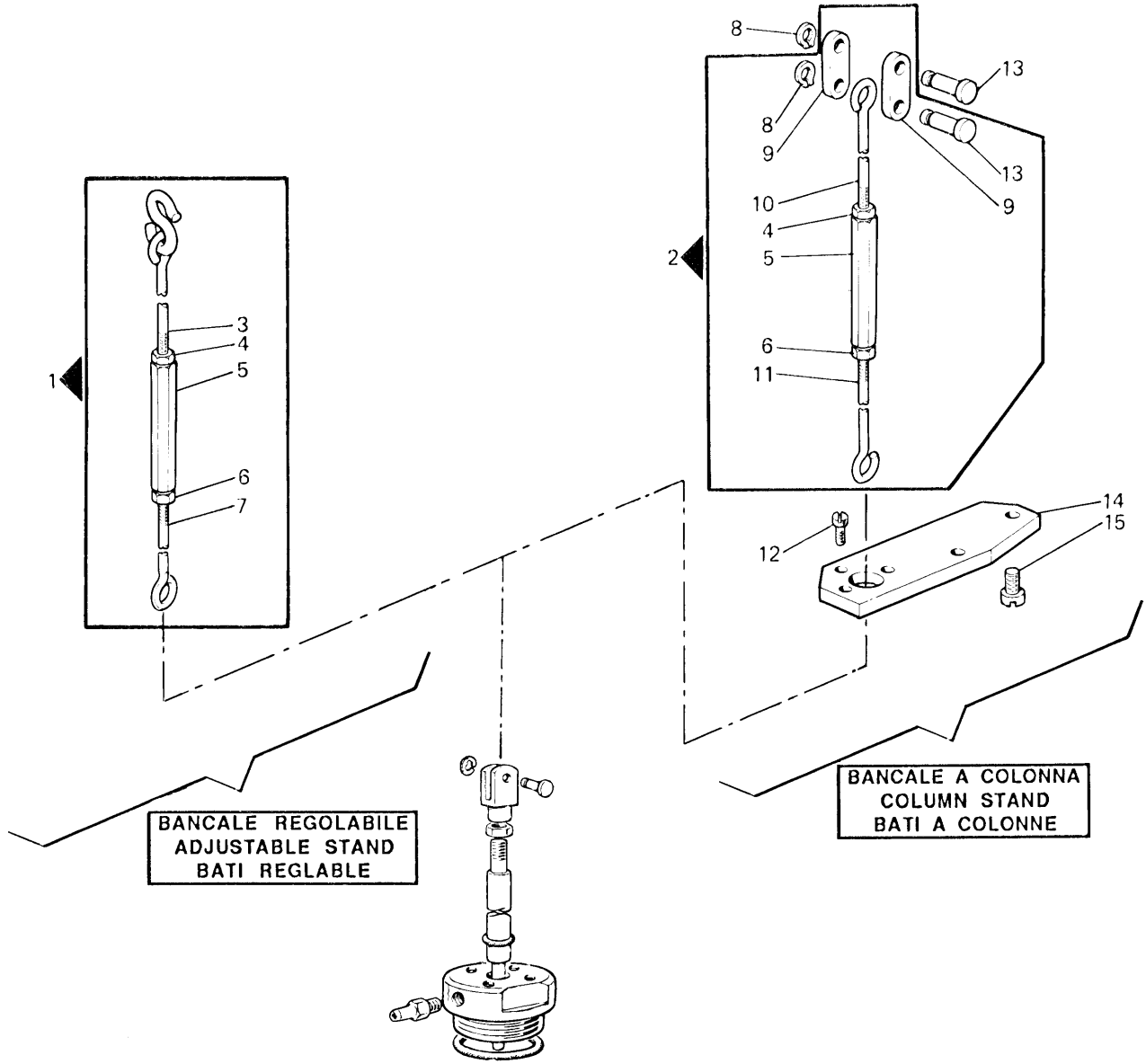

Rim® TAV. 8

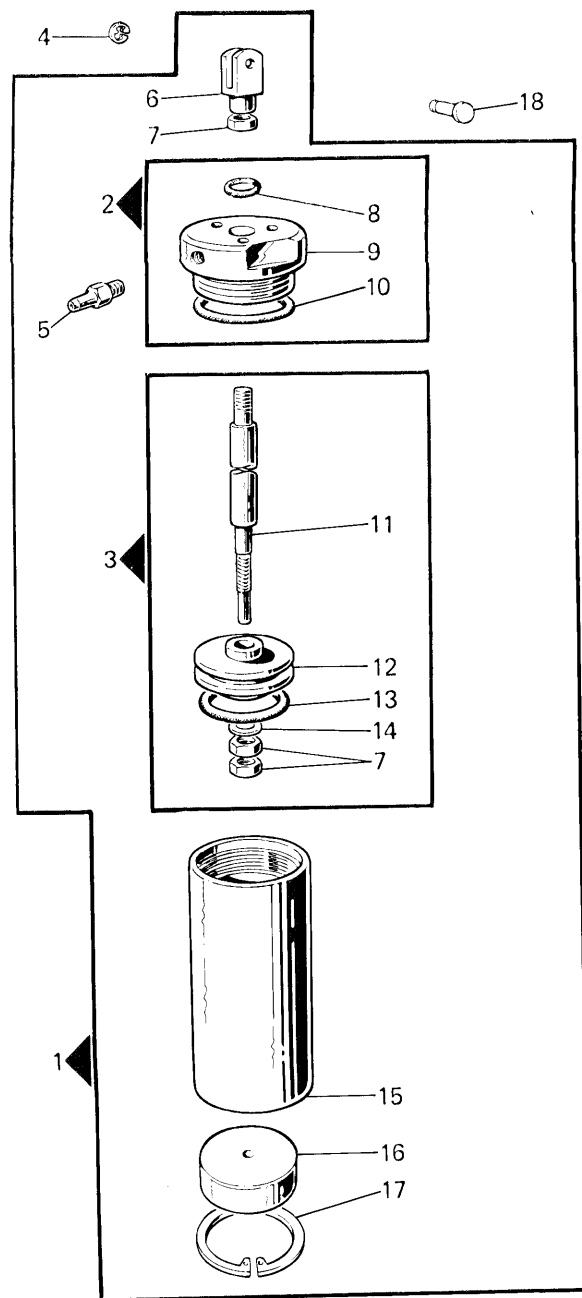
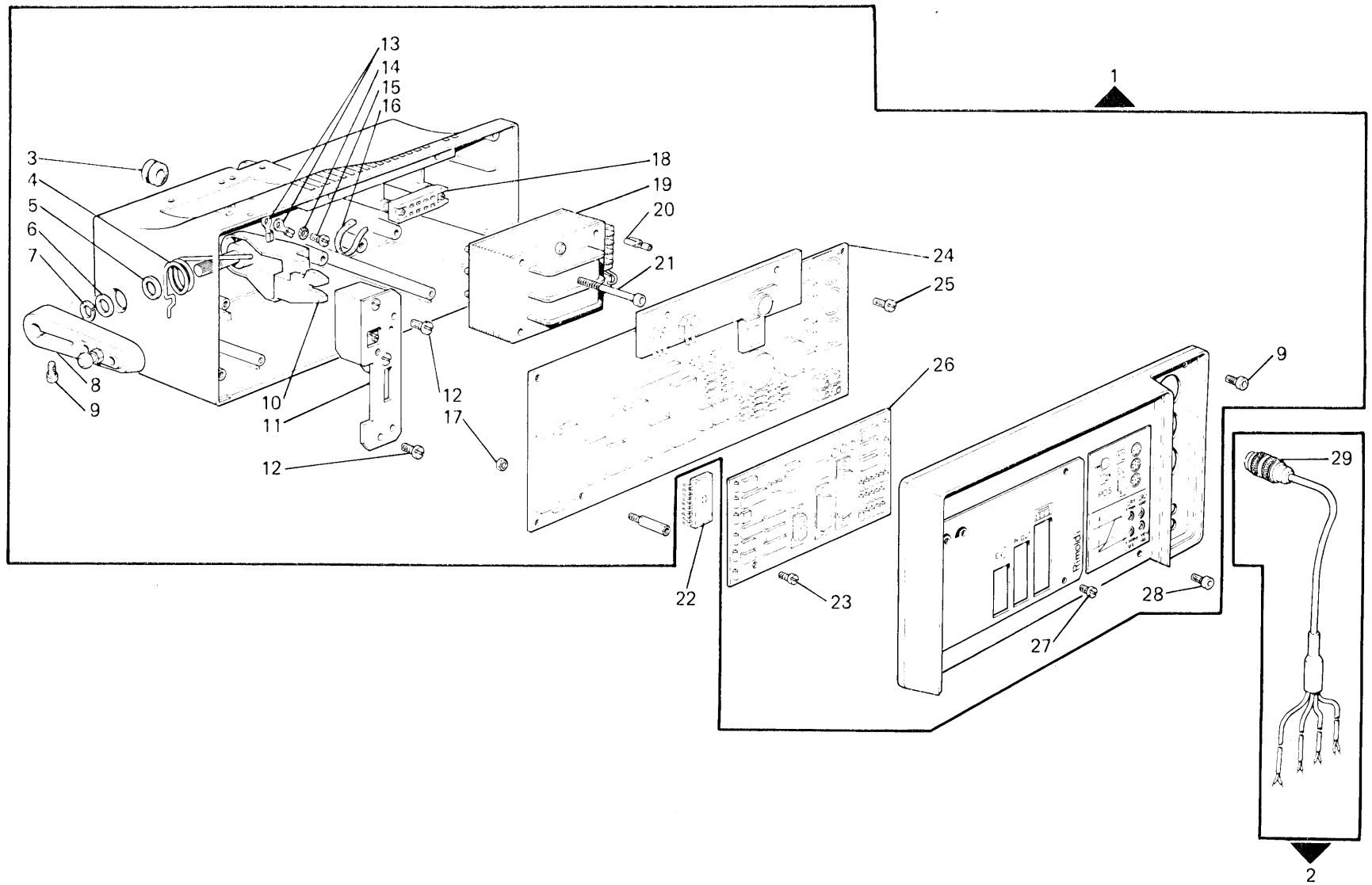

Fig. N.	Part. N. Piece N.	Qt.
1	924408-4-00	1
2	924807-4-10	1
3	924805-4-10	1
4	700205-0-00	1
5	924797-0-10	1
6	990310-0-10	1
7	746402-2-00	3
8	701007-0-00	1
9	924806-0-10	1
10	701132-0-00	1
11	924808-0-10	1
12	924804-0-10	1
13	701037-0-00	1
14	704218-2-00	1
15	924802-0-10	1
16	924407-0-01	1
17	700130-0-00	1
18	990311-0-10	1

Rim® TAV. 9

Fig. N.	Part. N. Piece N.	Qt.
1	800522-4-00	1
2	800437-4-00	1
3	923010-0-10	1
4	800116-0-00	1
5	704844-0-00	1
6	704841-0-00	1
7	700010-0-00	1
8	800132-2-00	1
9	722441-2-00	2
10	800129-2-00	1
11	800115-4-00	1
12	724462-2-00	2
13	910442-0-00	3
14	703305-0-00	1
15	741936-5-00	1
16	920258-0-10	1
17	926729-0-00	7
18	800319-0-00	1
19	800253-0-00	1
20	928007-0-00	4
21	722541-2-00	4
22	800370-0-00	1
23	741642-2-00	4
24	800500-4-00	1
25	722421-2-00	2
26	800511-4-00	1
27	741912-0-00	4
28	722531-0-00	3
29	923694-0-00	1



Rim® TAV. 10

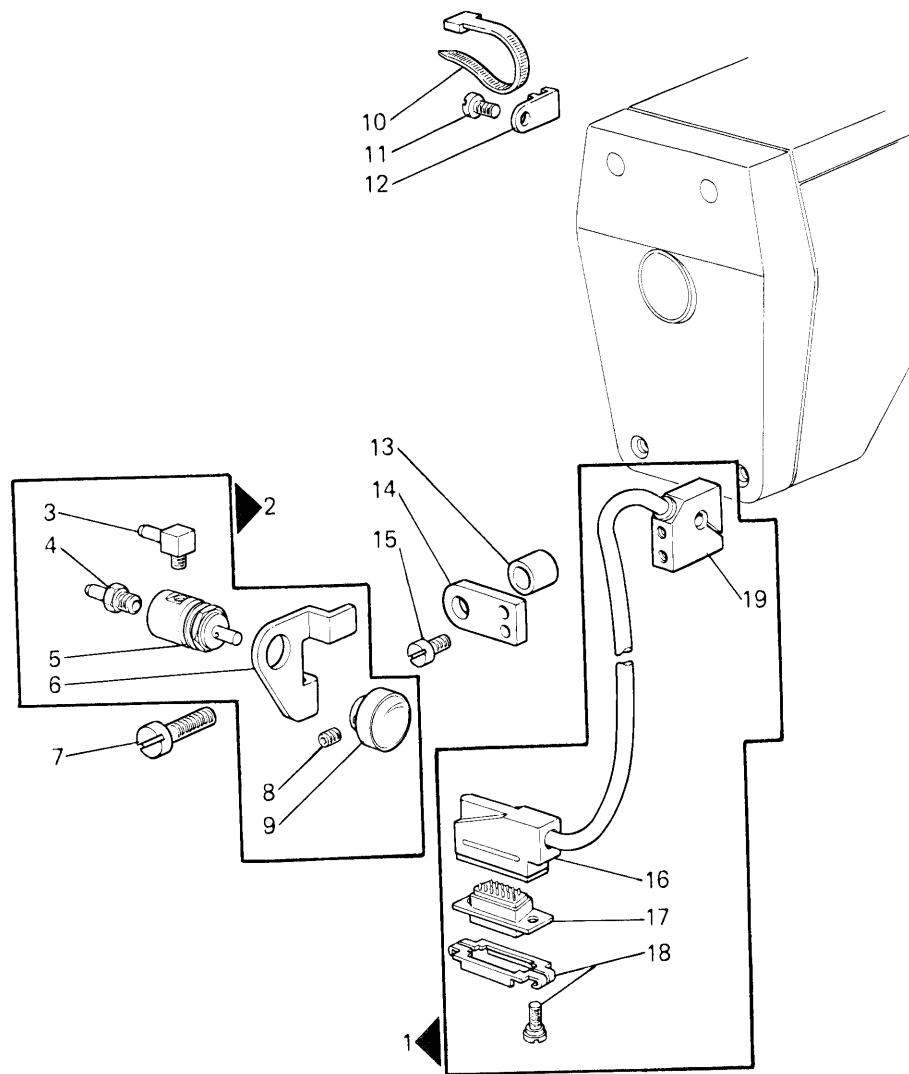
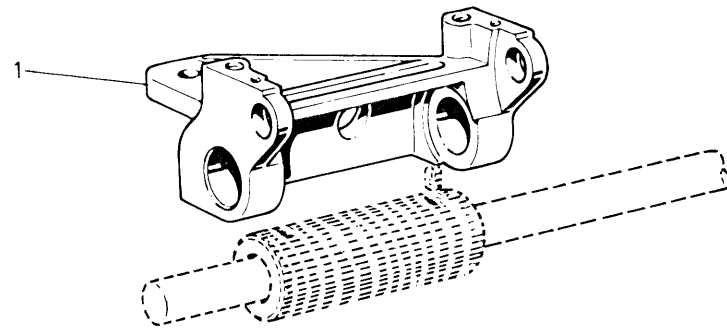

Fig. N.	Part. N. Piece N.	Qt.
1	800438-4-00	1
2	931837-4-00	1
3	943892-0-01	1
4	925659-0-00	1
5	924780-0-10	1
6	931835-0-00	1
7	930282-0-10	1
8	729011-2-00	1
9	924782-0-10	1
10	920258-0-10	1
11	303045-0-10	1
12	931836-0-10	1
13	921080-0-10	1
14	931705-0-00	1
15	741665-2-00	2
16	800272-0-00	1
17	800278-0-00	1
18	800275-0-00	1
19	929322-0-00	1

Rim® TAV. 11

Fig. N.	Part. N. Piece N.	Qt.
1	930855-4-00	1

- 261-34-2DR-25
- 261-34-2DR-26
- 261-34-2DR-43
- 261-34-3DR-18
- 263-34-2DR-20
- 263-34-2DR-22
- 263-34-2DR-27
- 263-34-3DR-16
- 263-34-3DR-30



BANCALE REGOLABILE
ADJUSTABLE STAND
DATI REGOLABILE

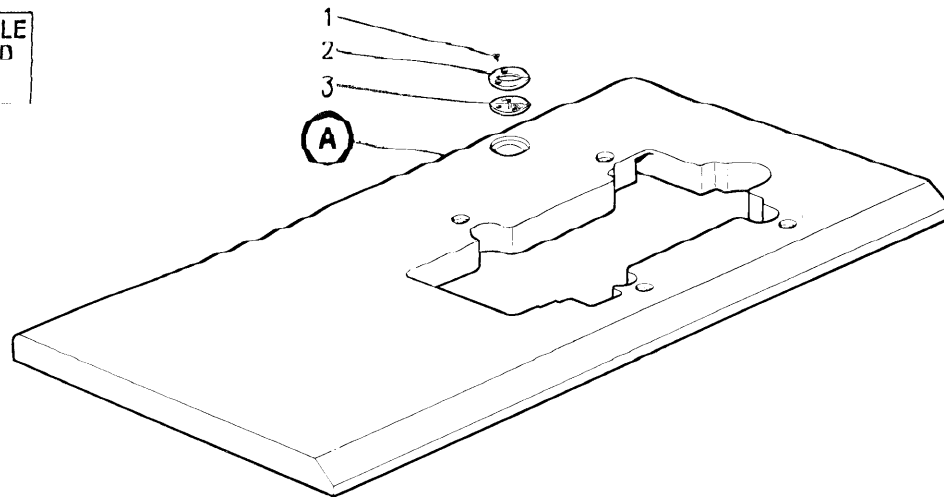

	(A)	(B)
194-ZA	929942-2-00	929944-2-00
194-ZB	929942-2-00	929944-2-00
194-ZC	929942-2-00	929944-2-00
194-ZD	929943-2-00	929945-2-00

BANCALE A COLONNA
COLUMN STAND
BATTI A COLONNE

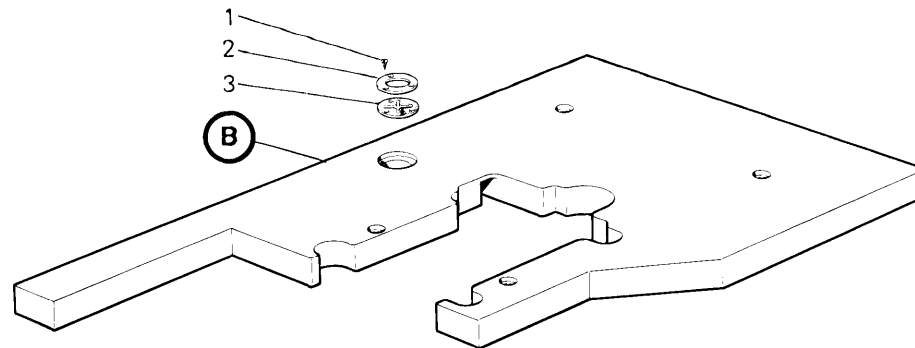

194-ZC
194-ZD

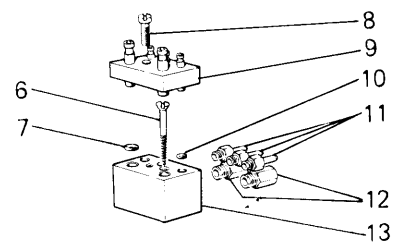

Rim® TAV. 12

Fig. N.	Part. N. Piece N.	Qt.
1	731244-0-00	6
2	921175-0-00	2
3	921176-0-00	2
4	990441-0-10	2
5	990442-0-10	2
6	731335-0-00	1
7	701006-0-00	2
8	722442-2-00	1
9	927714-2-00	1
10	701003-0-00	3
11	927655-0-00	3
12	941505-4-00	2
13	927706-4-00	1

Rim® TAV. 13

Fig. N.	Part. N. / Piece N.	Qt.
1	931268-4-00	1
2	925772-4-10	1
3	924870-0-10	1
4	941513-4-00	1
5	926305-0-00	1
6	943202-0-00	2
7	922846-4-00	1
8	923804-0-00	1
9	925557-0-00	1
10	902272-0-00	1
11	704011-4-00	1
12	720485-2-00	2
13	720525-2-00	1
14	704329-2-00	4
15	733006-2-00	2
16	925513-0-00	1

(A)

(B)

(C)

(D)

(E)

194-ZA

	(A)	(B)	(C)	(D)	(E)
METALWORK COLORE ARANCIO ORANGE COLOUR COLEUR ORANGE	924245-4-00	924233-0-00	924244-4-00	924238-0-00	924230-4-00
STAMPOTECNICA COLORE NERO BLACK COLOUR COLEUR NOIRE	925199-4-00	701133-0-00	925198-4-00	925196-0-00	925197-4-00

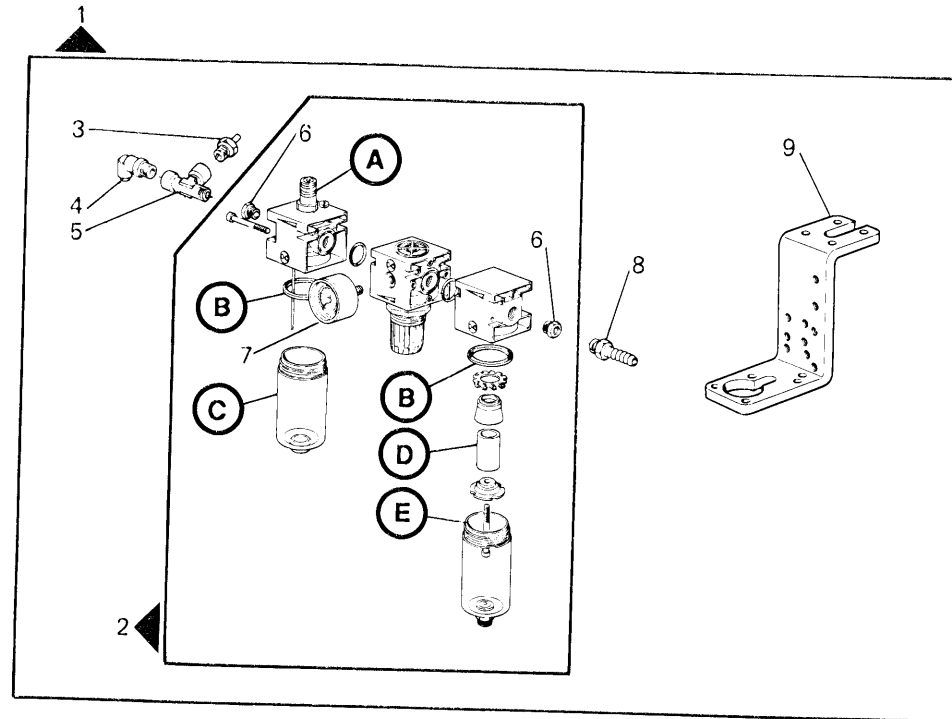

BANCALE REGOLABILE
ADJUSTABLE STAND
BATI REGLABLE

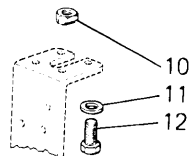

BANCALE A COLONNA
COLUMN STAND
BATI A COLONNE

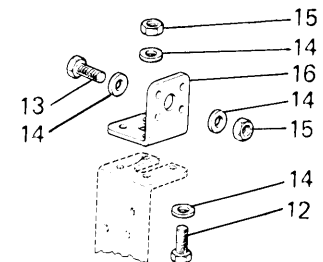

101-2B

	(A)	(B)	(C)	(D)	(E)
METALWORK COLORE ARANCIO ORANGE COLOUR COLEUR ORANGE	924245-4-00	924233-0-00	924244-4-00	924238-0-00	924239-4-00
STAMPOTECNICA COLORE NERO BLACK COLOUR COLEUR NOIRE	925199-4-00	701133-0-00	925198-4-00	925196-0-00	925197-4-00

Fig. N.	Part. N. Piece N.	Qt.
1	931269-4-00	1
2	925772-4-10	1
3	924870-0-10	2
4	941376-0-00	1
5	941513-4-00	1
6	923802-0-00	1
7	941511-4-00	2
8	943202-0-00	2
9	922846-4-00	1
10	925562-0-10	1
11	923804-0-00	1
12	925779-0-00	1
13	722481-2-00	2
14	942981-4-10	1
15	940421-4-01	1
16	902272-0-00	1
17	704011-4-00	1
18	720485-2-00	2
19	720525-2-00	1
20	704329-2-00	4
21	733006-2-00	2
22	925513-0-00	1

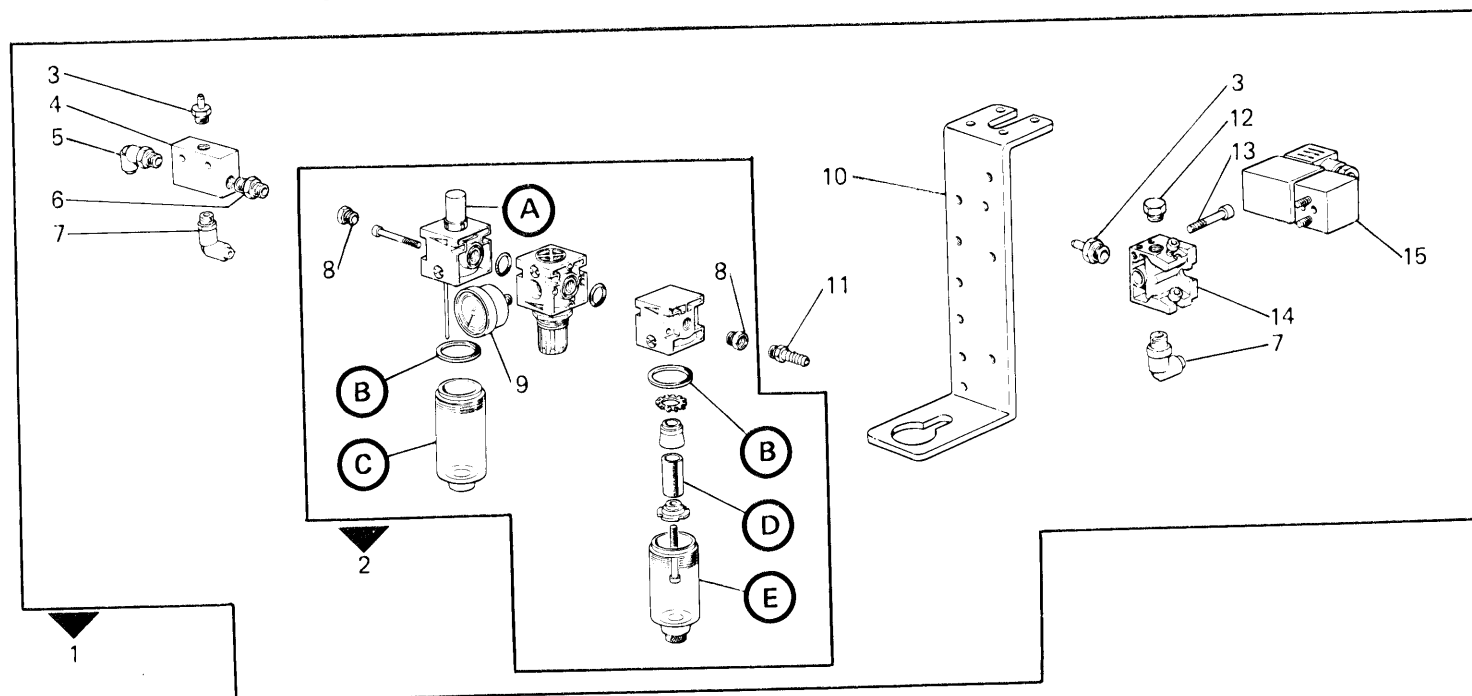

BANCALE REGOLABILE
ADJUSTABLE STAND
BATI REGLABLE

BANCALE A COLONNA
COLUMN STAND
BATI A COLONNE



Fig. N.	Part. N. Piece N.	Qt.
1	931266-4-00	1
2	925772-4-10	1
3	924870-0-10	3
4	941376-0-00	1
5	941513-4-00	1
6	923802-0-00	1
7	941511-4-00	2
8	943202-0-00	2
9	922846-4-00	1
10	925562-0-10	1
11	923804-0-00	1
12	924851-0-10	2
13	722511-2-00	2
14	929299-4-11	1
15	902272-0-00	1
16	704011-4-00	1
17	720485-2-00	2
18	720525-2-00	1
19	704329-2-00	4
20	733006-2-00	2
21	925513-0-00	1

	(A)	(B)	(C)	(D)	(E)
METALWORK COLORE ARANCIO ORANGE COLOUR COLEUR ORANGE	924245-4-00	924233-0-00	924244-4-00	924238-0-00	924239-4-00
STAMPOTECNICA COLORE NERO BLACK COLOUR COLEUR NOIRE	925199-4-00	701133-0-00	925198-4-00	925196-0-00	925197-4-00

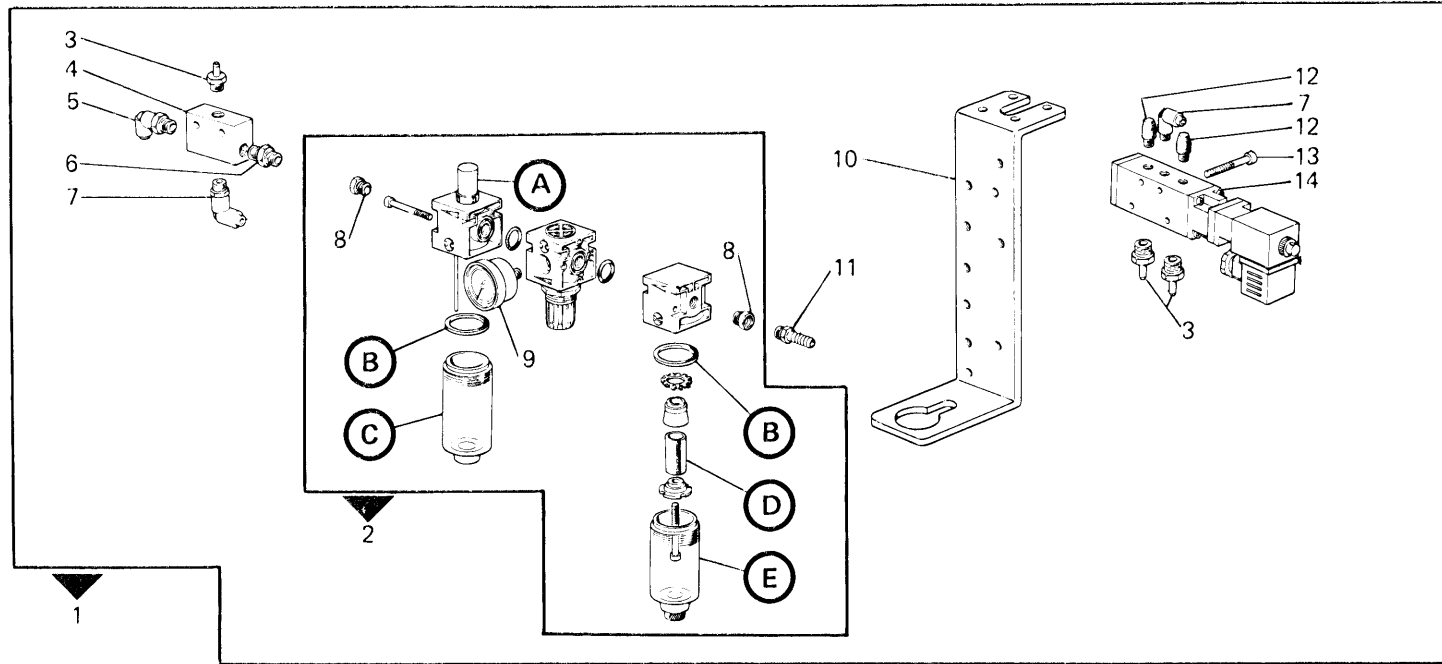

BANCALE REGOLABILE
ADJUSTABLE STAND
BATI REGLABLE

BANCALE A COLONNA
COLUMN STAND
BATI A COLONNE

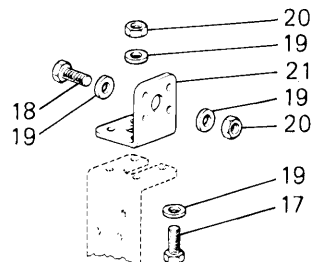
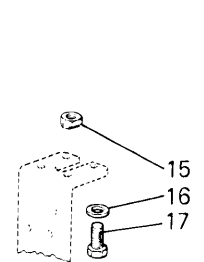

194-ZD

	(A)	(B)	(C)	(D)	(E)	(F)
METALWORK COLORE ARANCIO ORANGE COLOUR COLEUR ORANGE	924245-4-00	924233-0-00	924244-4-00	924238-0-00	924239-4-00	931437-2-00
STAMPOTECNICA COLORE NERO BLACK COLOUR COLEUR NOIRE	925199-4-00	701133-0-00	925198-4-00	925196-0-00	925197-4-00	925913-2-00

Rim® TAV. 16

Fig. N.	Part. N. Piece N.	Qt.
1	931267-4-00	1
2	925772-4-10	1
3	924870-0-10	4
4	941376-0-00	1
5	941513-4-00	1
6	923802-0-00	1
7	941511-4-00	4
8	943202-0-00	2
9	922846-4-00	1
10	941503-4-00	2
11	925562-0-10	1
12	923804-0-00	1
13	925779-0-00	1
14	722481-2-00	2
15	942981-4-10	1
16	940421-4-01	1
17	924851-0-10	2
18	722511-2-00	2
19	929299-4-11	1
20	923800-0-00	1
21	731105-0-00	4
22	902272-0-00	1
23	704011-4-00	1
24	720485-2-00	2
25	720525-2-00	1
26	704329-2-00	4
27	733006-2-00	2
28	925513-0-00	1

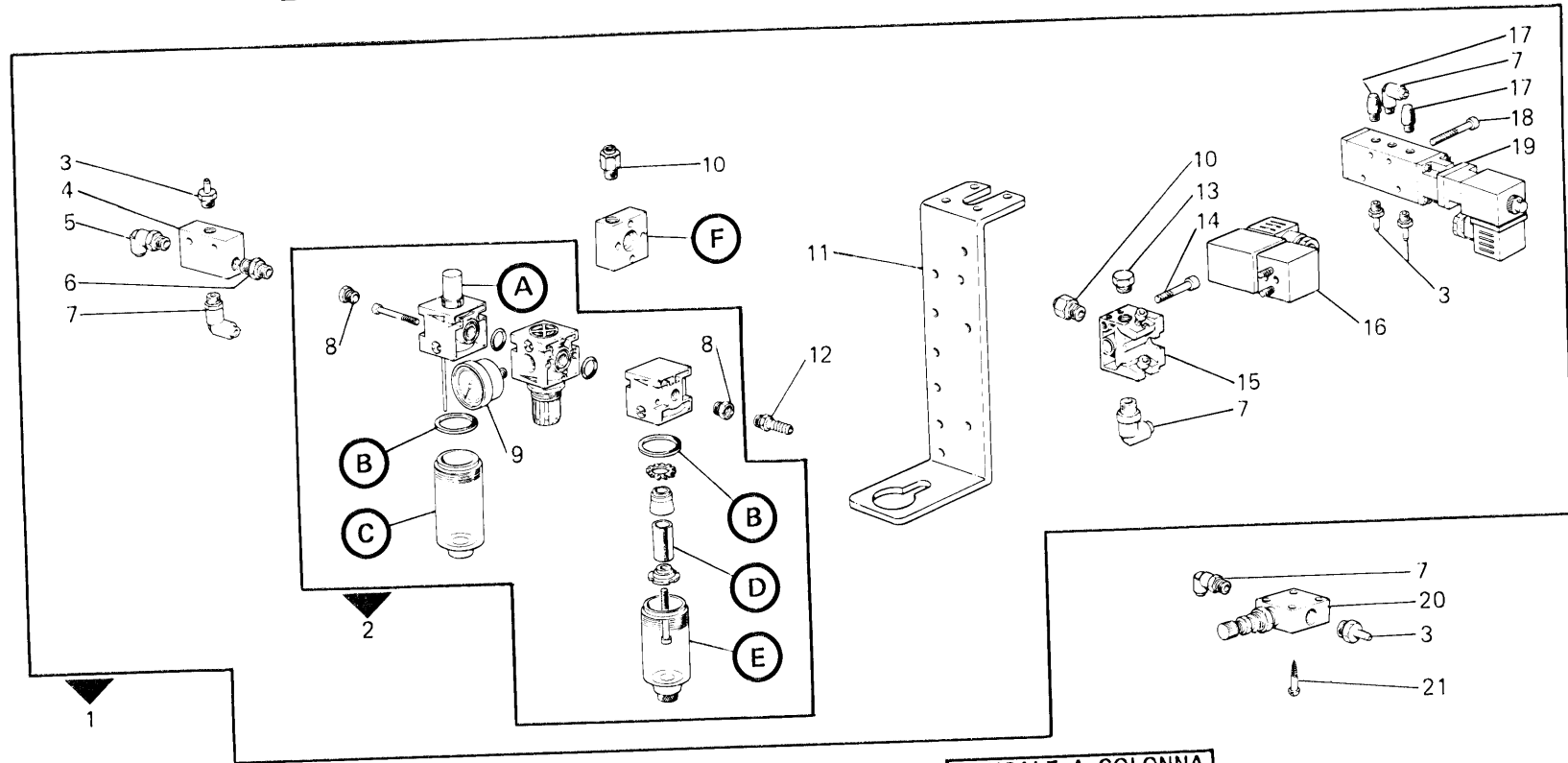

BANCALE REGOLABILE
ADJUSTABLE STAND
BATI REGLABLE

BANCALE A COLONNA
COLUMN STAND
BATI A COLONNE

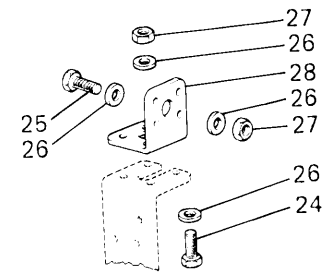
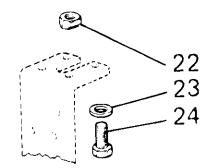

Rim® TAV.17

194-ZD

Fig. N.	Part. N. Piece N.	Qt.
1	929472-2-00	1
2	704108-2-00	1
3	944165-2-00	1
4	927393-0-00	1
5	990996-0-00	1
6	746402-2-00	1
7	300483-0-10	2
8	944167-0-00	1
9	990187-0-10	1
10	944381-0-00	1

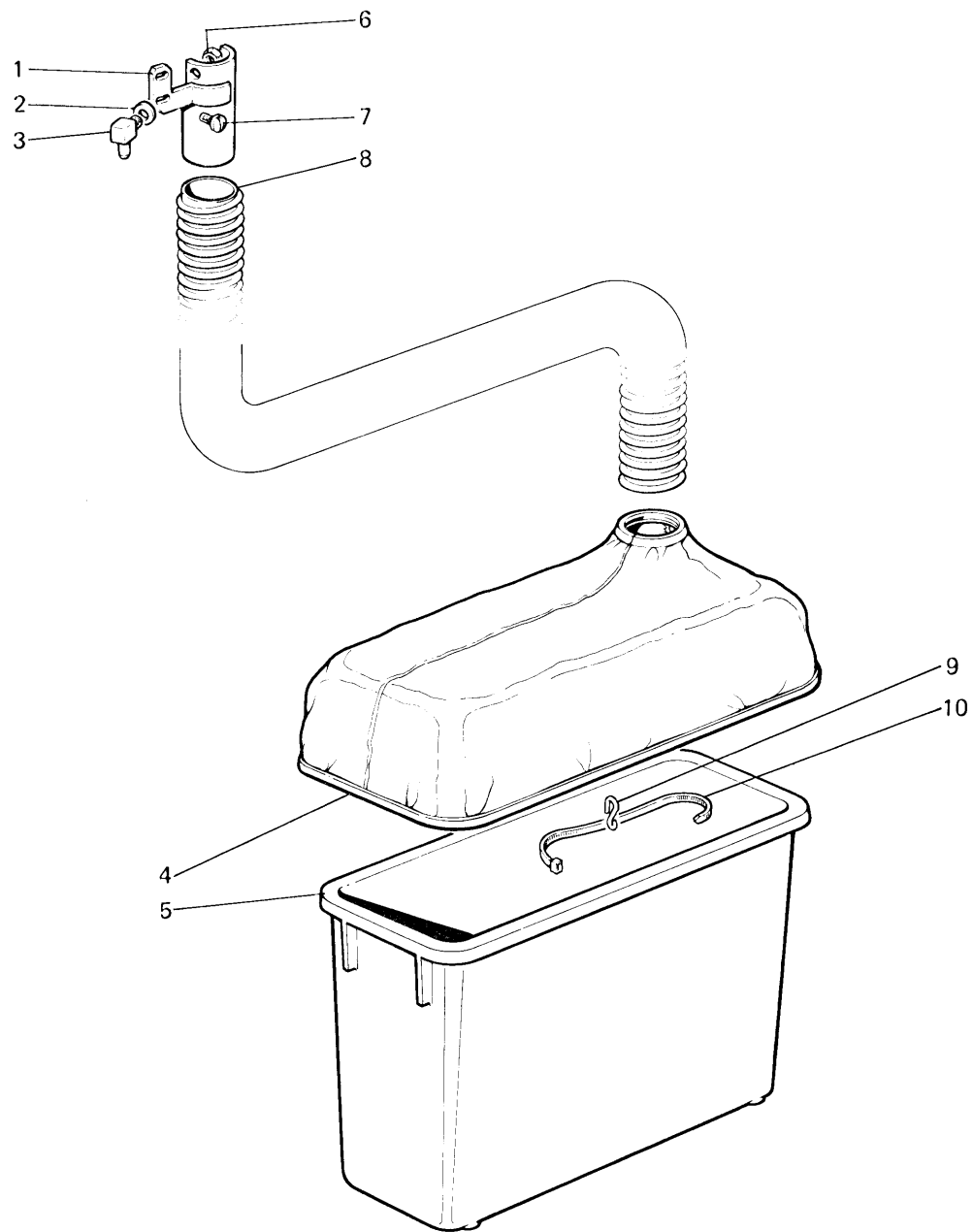

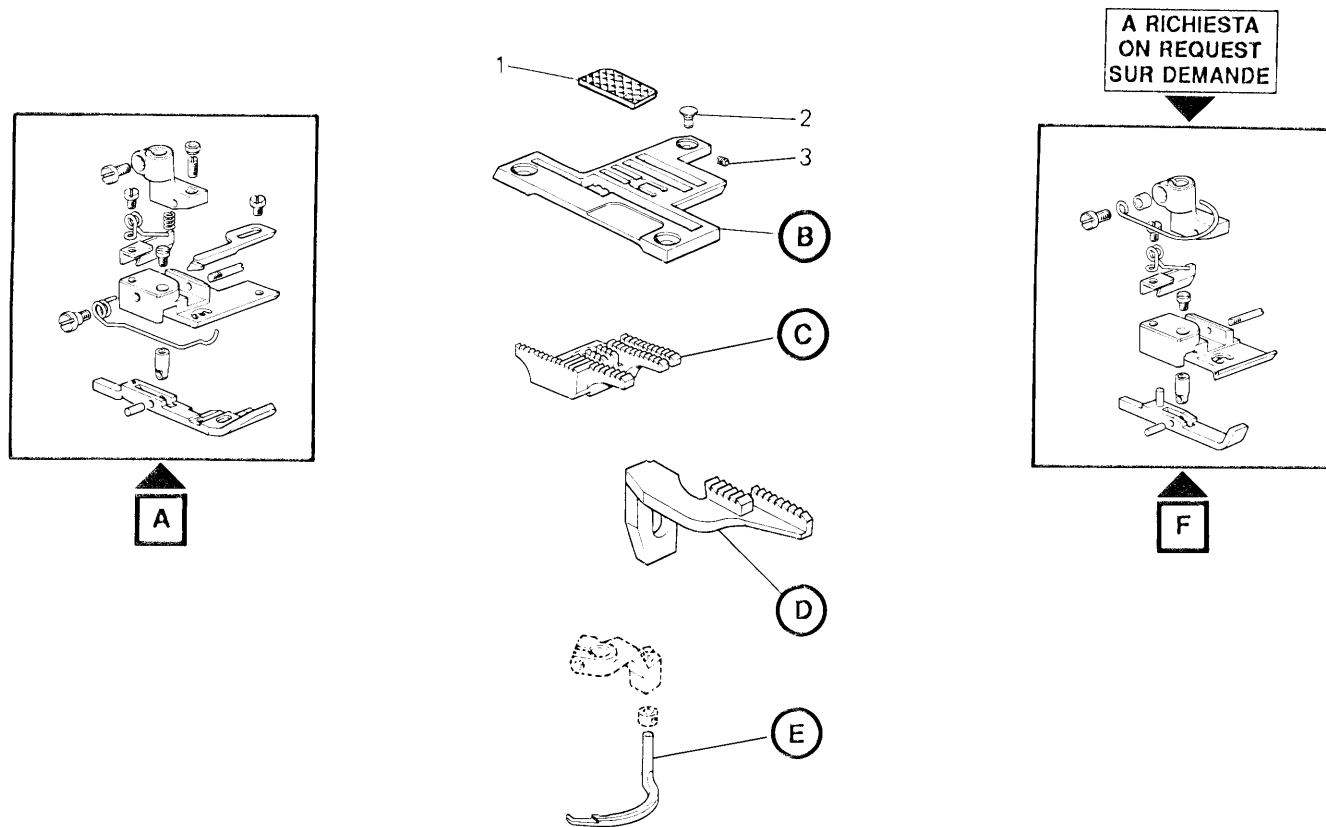

	(A)	(B)	(C)	(D)	(E)	(F)
261-16-2MD-04	929744-3-01	929741-0-10	929742-0-10	929743-0-10	—	929734-3-01
261-34-2DR-25	929746-3-01	929748-0-00	929749-0-00	929739-0-00	—	—
261-34-2DR-26	929704-3-01	929707-0-00	929708-0-00	929709-0-00	—	—
261-34-2DR-43	929746-3-01	929733-0-00	929749-0-00	929739-0-00	—	—
261-34-2WR-25	929746-3-01	929748-0-00	929749-0-00	929739-0-00	—	—
261-34-2WR-26	929704-3-01	929707-0-00	929708-0-00	929709-0-00	—	—
261-34-2WR-43	929746-3-01	929733-0-00	929749-0-00	929739-0-00	—	—
261-34-3DR-18	929787-3-00	929786-0-00	929708-0-00	929709-0-00	—	—
263-16-2MD-01	929744-3-01	929741-0-10	929742-0-10	929743-0-10	319093-0-00	—
263-16-2MD-10	929740-3-01	929745-0-10	929742-0-10	929743-0-10	319093-0-00	—
263-34-2DR-20	929746-3-01	929748-0-00	929749-0-00	929739-0-00	319093-0-00	—
263-34-2DR-22	929746-3-01	929733-0-00	929749-0-00	929739-0-00	319093-0-00	—
263-34-2DR-27	929704-3-01	929707-0-00	929708-0-00	929709-0-00	319093-0-00	—
263-34-2WR-20	929746-3-01	929748-0-00	929749-0-00	929739-0-00	319093-0-00	—
263-34-2WR-22	929746-3-01	929733-0-00	929749-0-00	929739-0-00	319093-0-00	—
263-34-2WR-27	929704-3-01	929707-0-00	929708-0-00	929709-0-00	319093-0-00	—
263-16-3MD-04	929790-3-01	929795-0-00	929793-0-00	929794-0-00	319093-0-00	—
263-34-3DR-16	929787-3-00	929786-0-00	929708-0-00	929709-0-00	319093-0-00	—
263-34-3DR-30	929787-3-00	929786-0-00	929708-0-00	929709-0-00	319093-0-00	—

Fig. N.	Part. N. Piece N.	Qt.
1	929940-0-00	1
2	929801-0-00	1
3	729011-2-00	1

Fig. N.	Part. N. Piece N.	Qt.
1	741721-2-00	6
2	741445-2-00	7
3	929306-0-00	7
4	929307-0-00	7
5	302821-0-10	3
6	743134-2-00	3
7	301598-0-11	3
8	301596-0-11	3
9	303052-0-00	3
10	741414-2-00	7
11	203658-0-10	2
12	304411-0-11	2
13	300120-0-10	7
14	303504-0-10	1
15	990808-0-01	1
16	741751-2-00	1
17	741413-2-00	1
18	302773-0-11	1

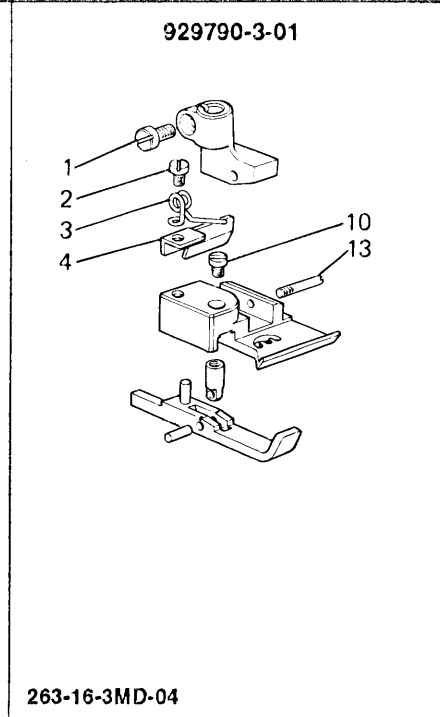
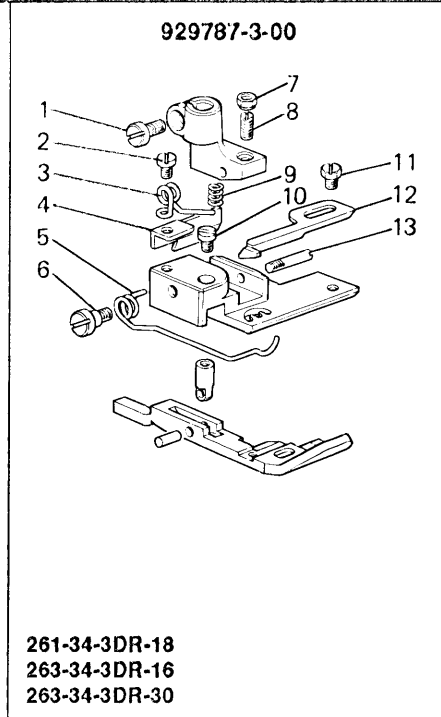
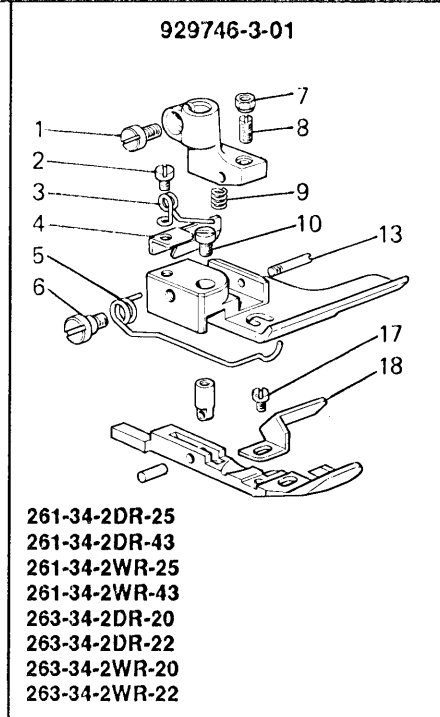
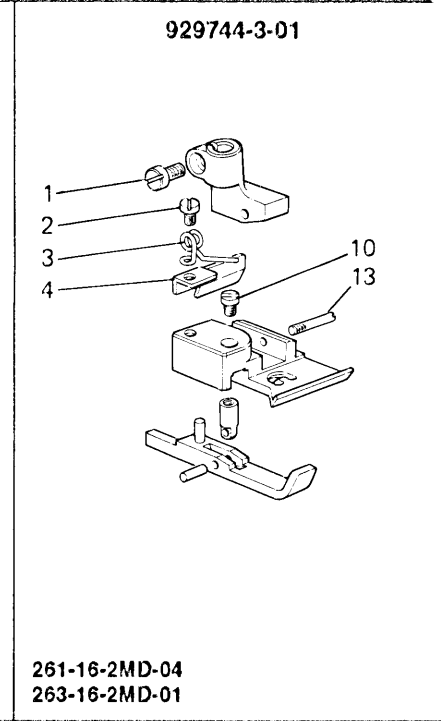
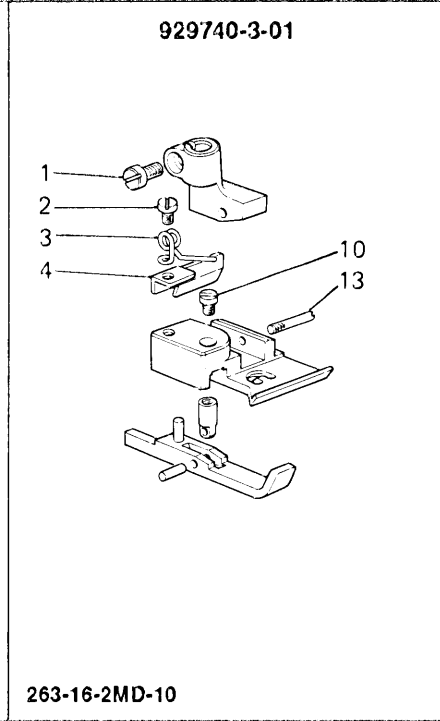
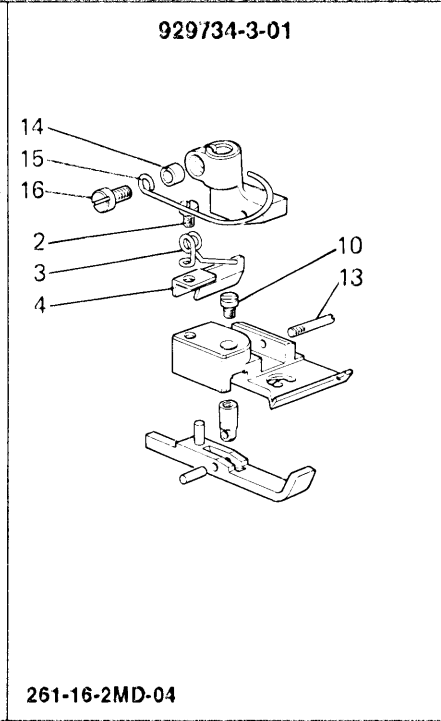
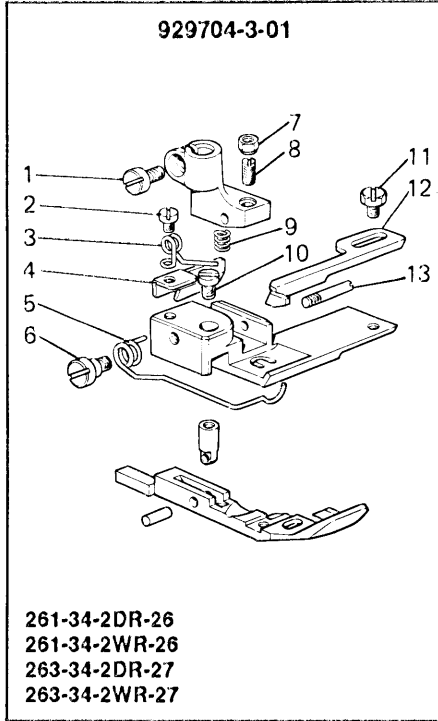

PLACCA AGO - NEEDLE PLATE - PLAQUE AIGUILLE

GRIFFA PRINC. - MAIN FEED DOG - GRIFFE PRINC.

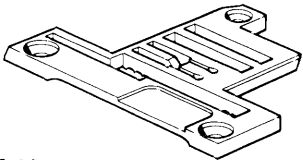
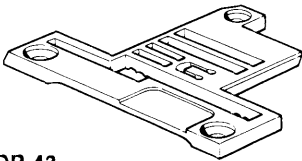
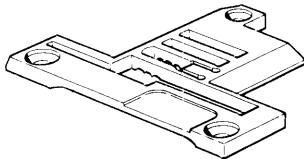
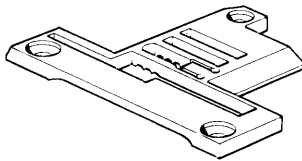
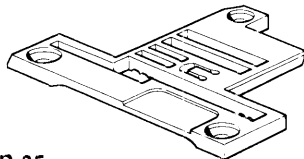
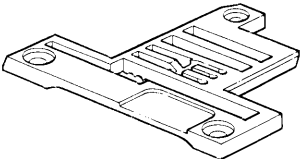
<p>929707-0-00</p>  <p>261-34-2DR-26 261-34-2WR-26 263-34-2DR-27 263-34-2WR-27</p>	<p>929733-0-00</p>  <p>261-34-2DR-43 261-34-2WR-43 263-34-2DR-22 263-34-2WR-22</p>
<p>929741-0-10</p>  <p>261-16-2MD-04 263-16-2MD-01</p>	<p>929745-0-10</p>  <p>263-16-2MD-10</p>
<p>929748-0-00</p>  <p>261-34-2DR-25 261-34-2WR-25 263-34-2DR-20 263-34-2WR-20</p>	<p>929786-0-00</p>  <p>261-34-3DR-18 263-34-3DR-16 263-34-3DR-30</p>

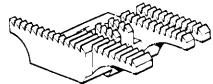
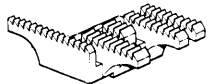
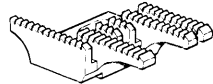
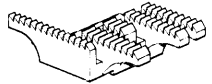
<p>929708-0-00</p>  <p>261-34-2DR-26 261-34-2WR-26 261-34-3DR-18 263-34-2DR-27 263-34-2WR-27 263-34-3DR-16 263-34-3DR-30</p>	<p>929742-0-10</p>  <p>261-16-2MD-04 263-16-2MD-01 263-16-2MD-10</p>
<p>929749-0-00</p>  <p>261-34-2DR-25 261-34-2DR-43 261-34-2WR-25 261-34-2WR-43 263-34-2DR-20 263-34-2DR-22 263-34-2WR-20 263-34-2WR-22</p>	<p>929793-0-00</p>  <p>263-16-3MD-04</p>

GRIFFA DIFFERENZ. - DIFFERENT. FEED DOG - GRIFFE DIFFERENT.

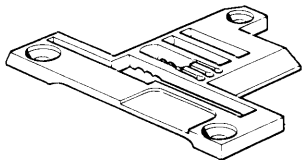
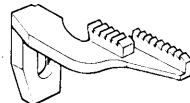
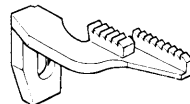
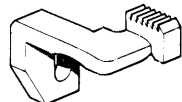
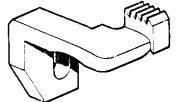
<p>929795-0-00</p>  <p>263-16-3MD-04</p>		<p>929709-0-00</p>  <p>261-34-2DR-26 261-34-2WR-26 261-34-3DR-18 263-34-2DR-27 263-34-2WR-27 263-34-3DR-16 263-34-3DR-30</p>	<p>929739-0-00</p>  <p>261-34-2DR-25 261-34-2DR-43 261-34-2WR-25 261-34-2WR-43 263-34-2DR-20 263-34-2DR-22 263-34-2WR-20 263-34-2WR-22</p>
		<p>929743-0-10</p>  <p>261-16-2MD-04 263-16-2MD-01 263-16-2MD-10</p>	<p>929794-0-00</p>  <p>263-16-3MD-04</p>

Rimoldi Srl - 33, Via Montebello - 20020 Olcella - Milano (Italy)
Tel. (0331) 563.111 - Telex 332299 - 312243 - Telefax (0331) 563.485 - 563.564