

**517-10**

PER TESTE 173-10-2MD-01  
FOR HEADS 173-10-3MD-01  
POUR TETES 173-34-3MR-02  
FÜR MASCHINEN  
POR CABEZALES

**517-40**

PER TESTA 173-16-2MK-01  
FOR HEAD  
POUR TETE  
FÜR MASCHINE  
POR CABEZAL

1a EDIZIONE-EDITION 9/89 **n. 452**

**APPARECCHIATURE  
ATTACHMENTS  
DISPOSITIFS  
VORRICHTUNGEN  
DISPOSITIVOS**

GUIDA PER LA CONSULTAZIONE DEL CATALOGO RICAMBI	GUIDELINES FOR THE USE OF THE SPARE PARTS CATALOGUE	GUIDE A LA CONSULTATION DU CATALOGUE PIECES DE RECHANGE	ANLEITUNG FÜR DIE BENUTZUNG DES ERSATZTEILKATALOGES	GUIA PARA LA CONSULTA DEL CATALOGO DE REPUESTOS
<p>Tutti i particolari che compongono i dispositivi e le varianti, in funzione delle teste sulle quali vengono montati, sono rappresentati in più tavole come indicato nell'indice.</p> <p>Ogni tavola riporta i componenti impiegati solo per i dispositivi elencati.</p>	<p>All the parts that are components of devices and the variants are represented in more tables as shown in the index, in relation to the head they are mounted on. Each table indicates the components relevant only to the listed devices.</p>	<p>Toutes les pièces qui composent les dispositifs et les variantes, en fonction des têtes sur lesquelles elles sont montées, ont été représentées sur plusieurs tables comme indiqué en index.</p> <p>Chaque table porte les composants employés uniquement pour les dispositifs énoncés.</p>	<p>Alle Teile welche die Vorrichtungen und die Varianten bilden sind, in Anbetracht auf die Oberteile auf welche sie angebaut werden, in mehreren Tafeln dargestellt, wie im Inhaltsverzeichnis angegeben. Jede Tafel führt nur die Teile für die angegebene Vorrichtung auf.</p>	<p>Todos los particulares que componen los dispositivos y las variantes, en función de los cabezales sobre los cuales vienen montados, son representados en más mesas como indicado en el índice. En cada mesa figuran los componentes empleados solo para los dispositivos relacionados.</p>
<p>Nelle tavole i particolari vengono riquadrati nei seguenti casi:</p> <ol style="list-style-type: none"> <li>1) Quando compongono un gruppo</li> <li>2) Quando compongono un sottogruppo</li> <li>3) Quando sono impiegati solo per i dispositivi elencati nel riquadro.</li> </ol>	<p>Some symbols are represented within a square in the following cases:</p> <ol style="list-style-type: none"> <li>1) When they are part of an assembly</li> <li>2) When they are part of a sub-assembly</li> <li>3) When they are used only for the devices listed in a square.</li> </ol>	<p>Sur les tables les composants sont bordés dans les suivants cas:</p> <ol style="list-style-type: none"> <li>1) Quand ils composent un groupe</li> <li>2) Quand ils composent un sous-groupe</li> <li>3) Quand ils sont employés uniquement pour les dispositifs énoncés en bordure (en marge).</li> </ol>	<p>In den Tafeln werden die Teile in folgenden Fällen umrahmt:</p> <ol style="list-style-type: none"> <li>1) Wenn sie eine Teilegruppe bilden</li> <li>2) Wenn sie eine Untergruppe bilden</li> <li>3) Wenn sie nur für die in der Umrahmung angeführten Vorrichtungen benutzt werden.</li> </ol>	<p>En las mesas y particulares vienen encuadrados en los siguientes casos:</p> <ol style="list-style-type: none"> <li>1) Cuando componen un grupo</li> <li>2) Cuando componen un subgrupo</li> <li>3) Cuando son empleados solo para los dispositivos relacionados en el recuadro.</li> </ol>
<p>Un particolare o un gruppo viene richiamato con una lettera nei seguenti casi:</p> <ol style="list-style-type: none"> <li>1) Quando non sono comuni a tutte le teste sulle quali vengono montati i dispositivi</li> <li>2) Quando non sono comuni a tutti i dispositivi riportati nel catalogo</li> <li>3) Quando esistono alternative del medesimo particolare o gruppo.</li> </ol> <p>Per la loro consultazione, rimandiamo alle relative tabelle delle varianti pubblicate nella stessa tavola oppure nelle ultime pagine del catalogo.</p>	<p>A letter refers to a part or to an assembly in the following cases:</p> <ol style="list-style-type: none"> <li>1) When they are not common to all heads the devices are mounted on</li> <li>2) When they are not common to all devices shown in the catalogue</li> <li>3) When there are alternatives to the same part or assembly.</li> </ol> <p>In this case, refer to the relative charts of variables published in the same table or in the last pages of the catalogue.</p>	<p>Un composant ou un groupe est rappelé avec une lettre dans les cas suivants:</p> <ol style="list-style-type: none"> <li>1) Quand il n'est pas commun à toutes les têtes sur lesquelles on monte les dispositifs</li> <li>2) Quand il n'est pas commun à tous les dispositifs énoncés sur le catalogue</li> <li>3) Quand il existe des alternatives du même composant ou groupe.</li> </ol> <p>Pour leur consultation, se référer aux relatives fiches des variantes publiées sur la table même ou dans les dernières pages du catalogue.</p>	<p>Ein Teil oder eine Teilegruppe wird in folgenden Fällen mit einem Buchstaben gekennzeichnet:</p> <ol style="list-style-type: none"> <li>1) Wenn das Teil oder die Gruppe nicht gleich ist für den Anbau an alle Oberteile an welche die Vorrichtungen angebaut werden</li> <li>2) Wenn das Teil oder die Gruppe nicht für alle im Katalog angeführten Vorrichtungen gemein ist</li> <li>3) Wenn für dasselbe Teil oder dieselbe Teilegruppe Alternativen bestehen</li> </ol> <p>Für deren zu Rateziehung verweisen wir auf die auf derselben Tafel angeführten Tabellen der Varianten oder auf die letzten Seiten des Kataloges.</p>	<p>Un particular o un grupo viene llamado con una letra en los siguientes casos:</p> <ol style="list-style-type: none"> <li>1) Cuando no son comunes a todos los cabezales sobre los cuales vienen montados los dispositivos</li> <li>2) Cuando no son comunes a todos los dispositivos que figuran en el catalogo</li> <li>3) Cuando existen alternativas del mismo particular o grupo</li> </ol> <p>Para su consulta ver las relativas tablas de las variantes publicadas en la misma mesa o bien en las últimas páginas del catalogo.</p>
<p>Gli organi di cucitura, le guide e gli accessori sono preceduti da tavole riepilogative con l'indicazione dei particolari in dotazione e di quelli a richiesta.</p>	<p>The sewing parts, guides, folders and accessories are preceded by summary tables indicating standard parts and parts supplied on request.</p>	<p>Les éléments de couture, les guides et les accessoires sont précédés de tables de récapitulations avec l'index des composants en dotation et ceux sur demande.</p>	<p>Vor den Tafeln mit den Nähwerkzeugen, Führungen und Ausstattungen befinden sich zusammenfassende Tafeln mit Angabe der in Normalausstattung und der auf Anfrage lieferbaren Teile.</p>	<p>Los órganos de costura, las guías y los accesorios son precedidos de un resumen de mesas con la indicación de particulares en dotación y de los solicitados.</p>
<p>Per ordini di aghi, precisare il simbolo riportato in catalogo; in caso di dubbio allegare un ago campione o una bustina vuota.</p>	<p>When ordering needles, please specify catalogue symbol; if you have doubts, send a sample needle or an empty needle bag with your order.</p>	<p>Pour les commandes d'aiguilles, préciser le symbole indiqué sur le catalogue, en cas de doute joindre une aiguille échantillon ou un sachet vide.</p>	<p>Für Aufträge über Nähadeln ist die im Ersatzteilkatalog angeführte Teilenummer anzugeben; in Zweifelsfällen ist eine Nadel als Muster oder ein entsprechender leerer Nadelbrief beizulegen.</p>	<p>Por pedido de agujas, precisar el símbolo que figura en el catalogo, en caso de duda adjuntar una aguja modelo o un sobre vacío.</p>

# Rim® TAV. 1

Fig. N.	Part. N. / Piece N.	Qt.
1	928320-4-02	1
2	308556-0-00	1
3	705201-0-00	1
4	740250-2-00	1
5	924396-0-10	1
6	741433-2-00	2
7	302172-0-10	1
8	308558-0-00	1
9	304905-0-10	1
10	302204-0-10	1
11	930066-0-10	1
12	704218-2-00	1
13	200324-0-10	2
14	300393-0-10	1
15	310459-0-01	1
16	741612-2-00	1
17	302168-0-00	1
18	741655-2-00	1
19	746002-2-00	1
20	721444-2-00	2
21	740220-2-00	2
22	704104-2-00	2
23	311188-0-02	1
24	309314-2-00	1

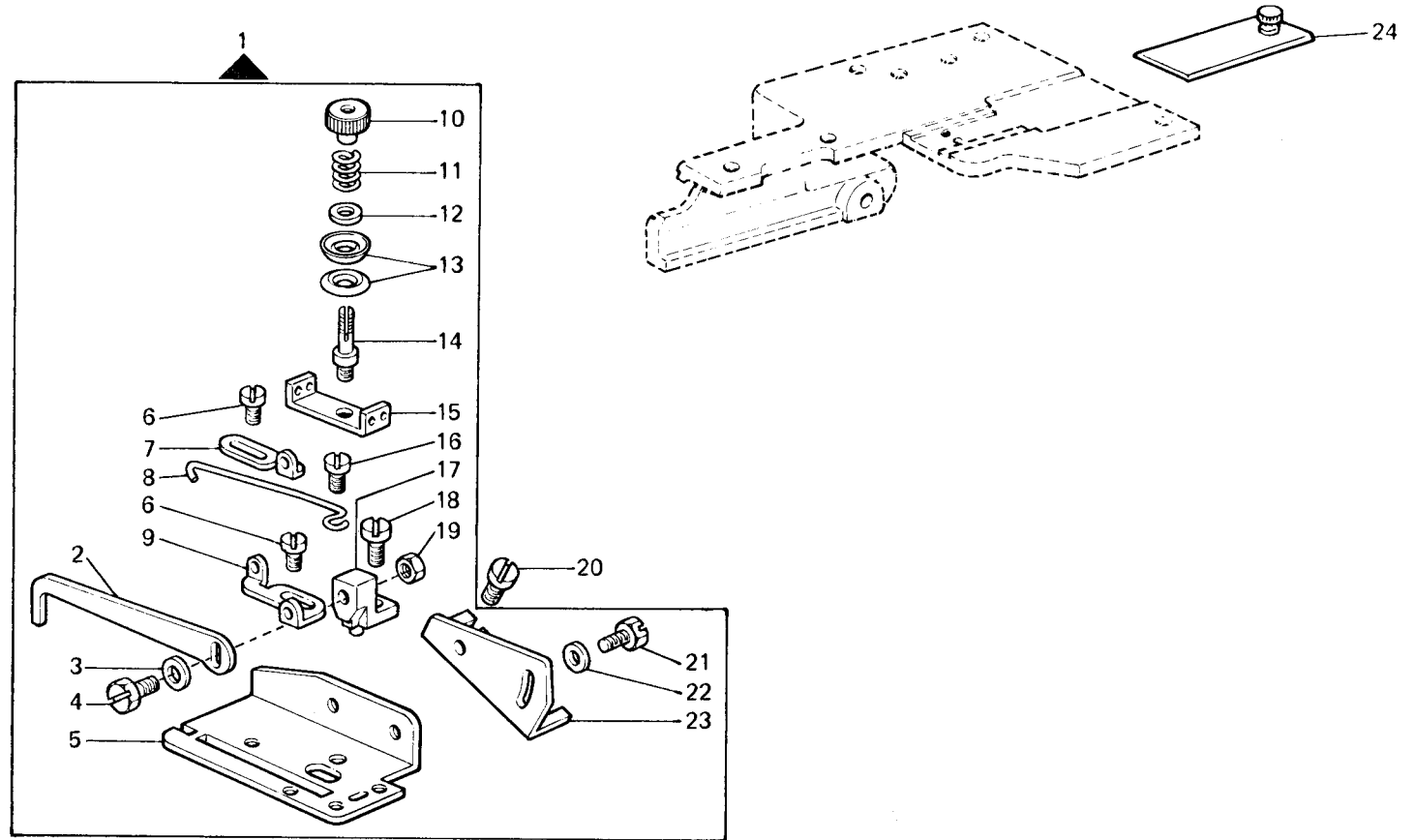

# Rim® TAV. 2

Fig. N.	Part. N. Piece N.	Qt.
1	932241-4-00	1
2	308864-4-01	1
3	746007-2-00	1
4	308865-0-00	1
5	740236-0-00	2
6	741658-2-00	2
7	302134-0-10	1
8	308874-0-00	2
9	308862-0-01	1
10	308863-0-00	2
11	308860-0-00	1
12	308861-0-00	1

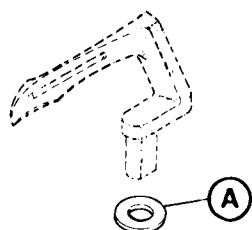
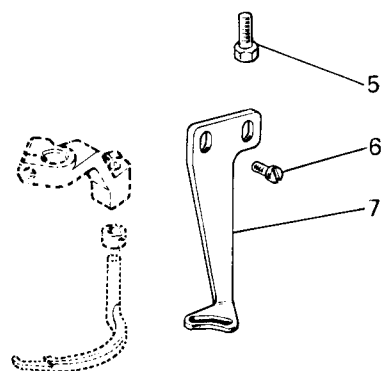
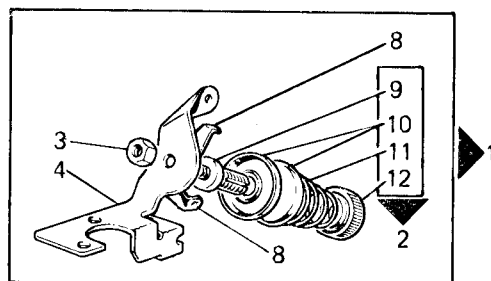

(A)	
173-10-2MD-01	704218-2-00
173-10-3MD-01	704108-2-00
173-16-2MK-01	704218-2-00
173-34-3MR-02	704108-2-00

# Rim® TAV. 3

Fig. N.	Part. N. / Piece N.	Qt.
1	932219-4-00	1
2	932244-4-00	1
3	705408-0-00	2
4	924727-0-20	1
5	304243-0-10	1
6	741956-2-00	2
7	924730-0-20	1
8	724411-0-00	1
9	924729-0-10	1
10	943765-0-01	2
11	741403-4-00	3
12	924048-0-00	1
13	745810-5-00	1
14	924980-2-11	1
15	924049-0-00	1
16	924045-0-00	1
17	701004-0-00	1
18	924046-0-00	1
19	924402-0-00	1
20	701007-0-00	1
21	701003-0-00	1
22	924047-0-00	1
23	722070-2-00	2
24	722123-2-00	2

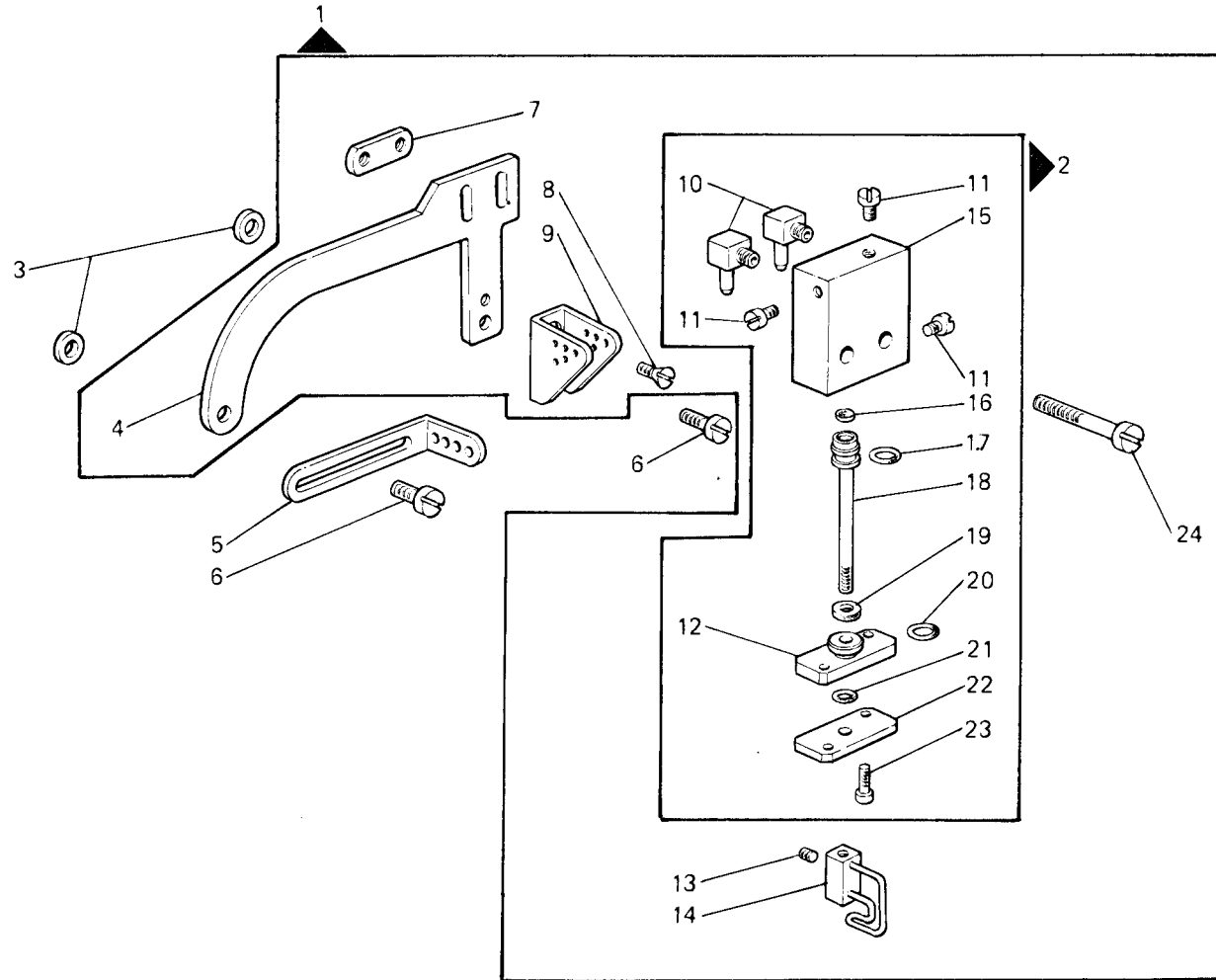

# Rim® TAV. 4

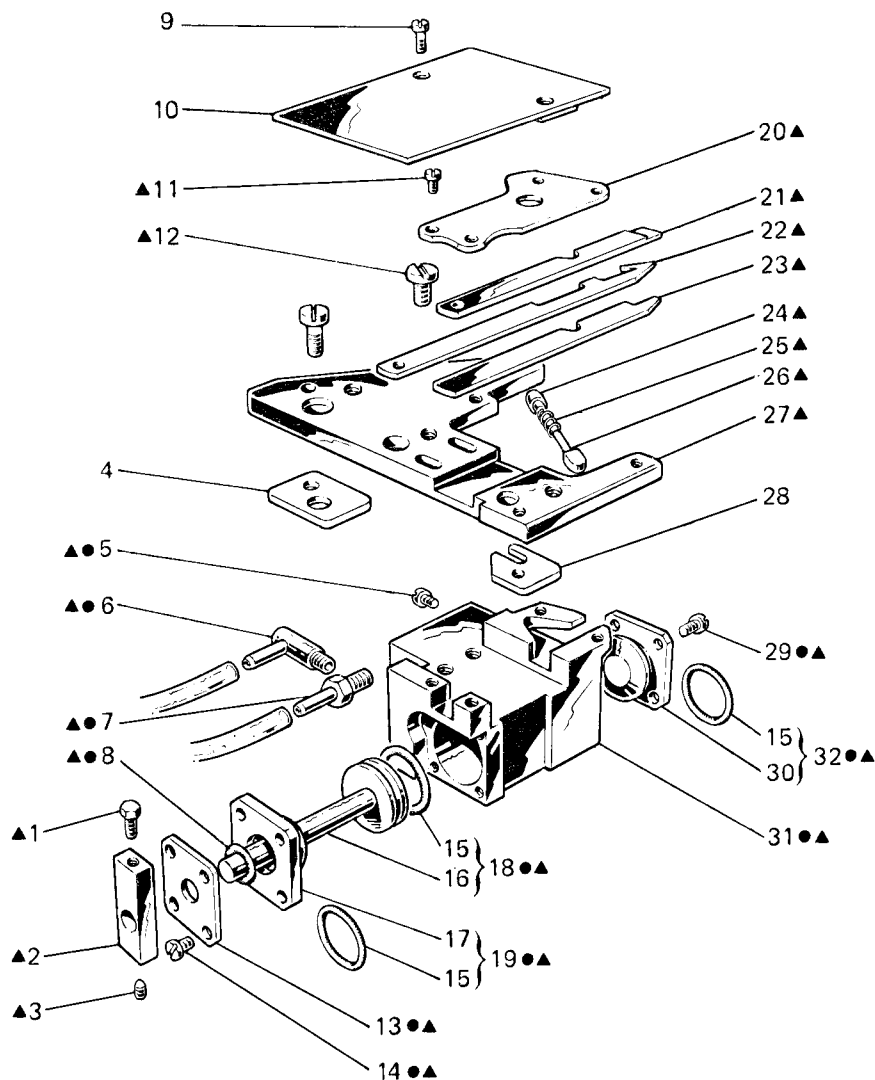
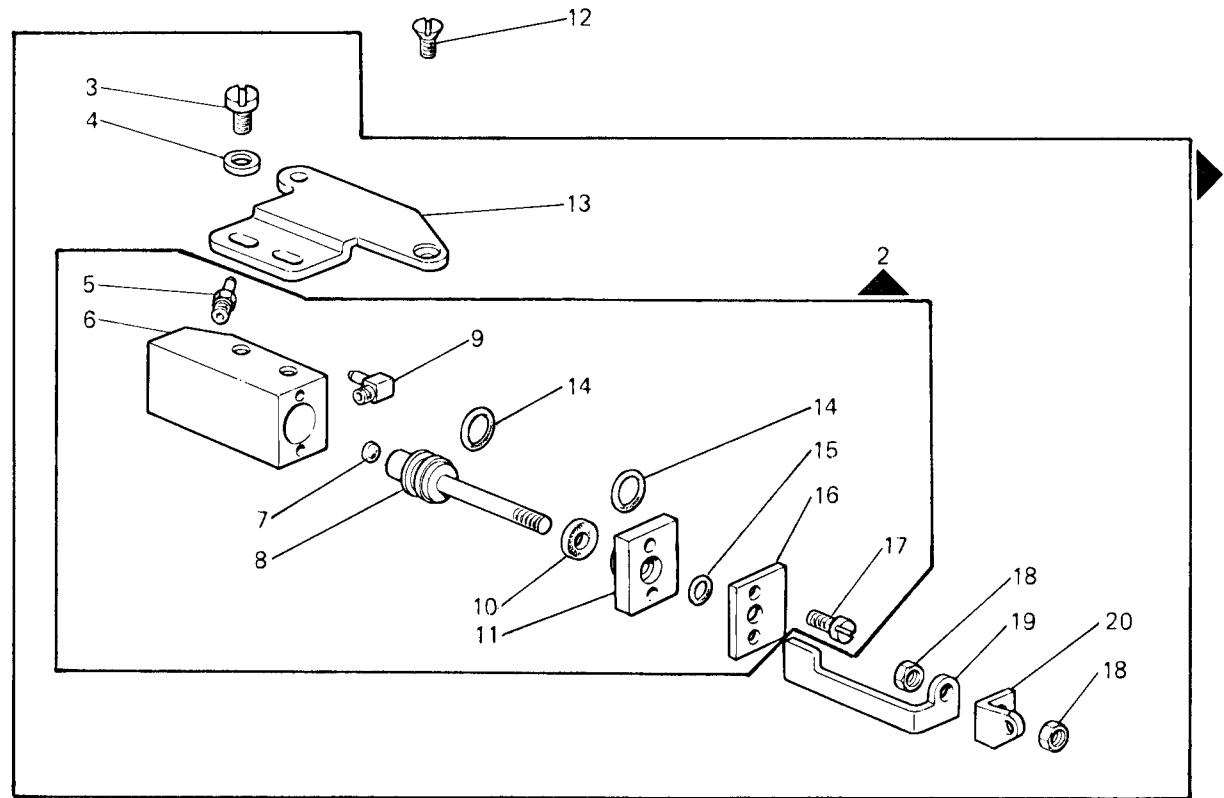

Fig. N.	Part. N. Piece N.	Qt.
▲●	932227-4-00	1
●	924391-4-01	1
1	924763-0-10	1
2	924668-0-10	1
3	730011-2-00	1
4	924476-0-00	1
5	741405-4-00	1
6	924392-0-01	1
7	924393-0-00	1
8	701003-0-00	1
9	741913-4-00	2
10	924471-2-00	1
11	744530-0-00	4
12	741956-2-00	2
13	924663-0-10	1
14	741461-2-00	4
15	701009-0-00	3
16	924659-0-11	1
17	924661-0-11	1
18	924660-4-11	1
19	924662-4-11	1
20	925831-4-00	1
21	944422-0-00	1
22	924607-0-00	1
23	924608-0-00	1
24	924675-0-10	1
25	100893-0-09	1
26	924674-0-10	1
27	924472-2-00	1
28	924135-0-00	1
29	741431-2-00	4
30	924664-0-11	1
31	924656-0-11	1
32	924665-4-11	1

# Rim® TAV. 5

Fig. N.	Part. N. / Piece N.	Qt.
1	924044-4-00	1
2	924030-4-00	1
3	741936-2-00	2
4	704210-4-00	2
5	924701-0-11	1
6	924039-0-00	1
7	924045-0-00	1
8	924031-0-01	1
9	943765-0-01	1
10	924731-0-20	1
11	924032-0-00	1
12	724462-2-00	1
13	924483-0-00	1
14	701009-0-00	2
15	701003-0-00	1
16	924033-0-00	1
17	722070-2-00	2
18	733505-2-00	2
19	924485-0-10	1
20	924484-0-10	1



# Rim® TAV. 6

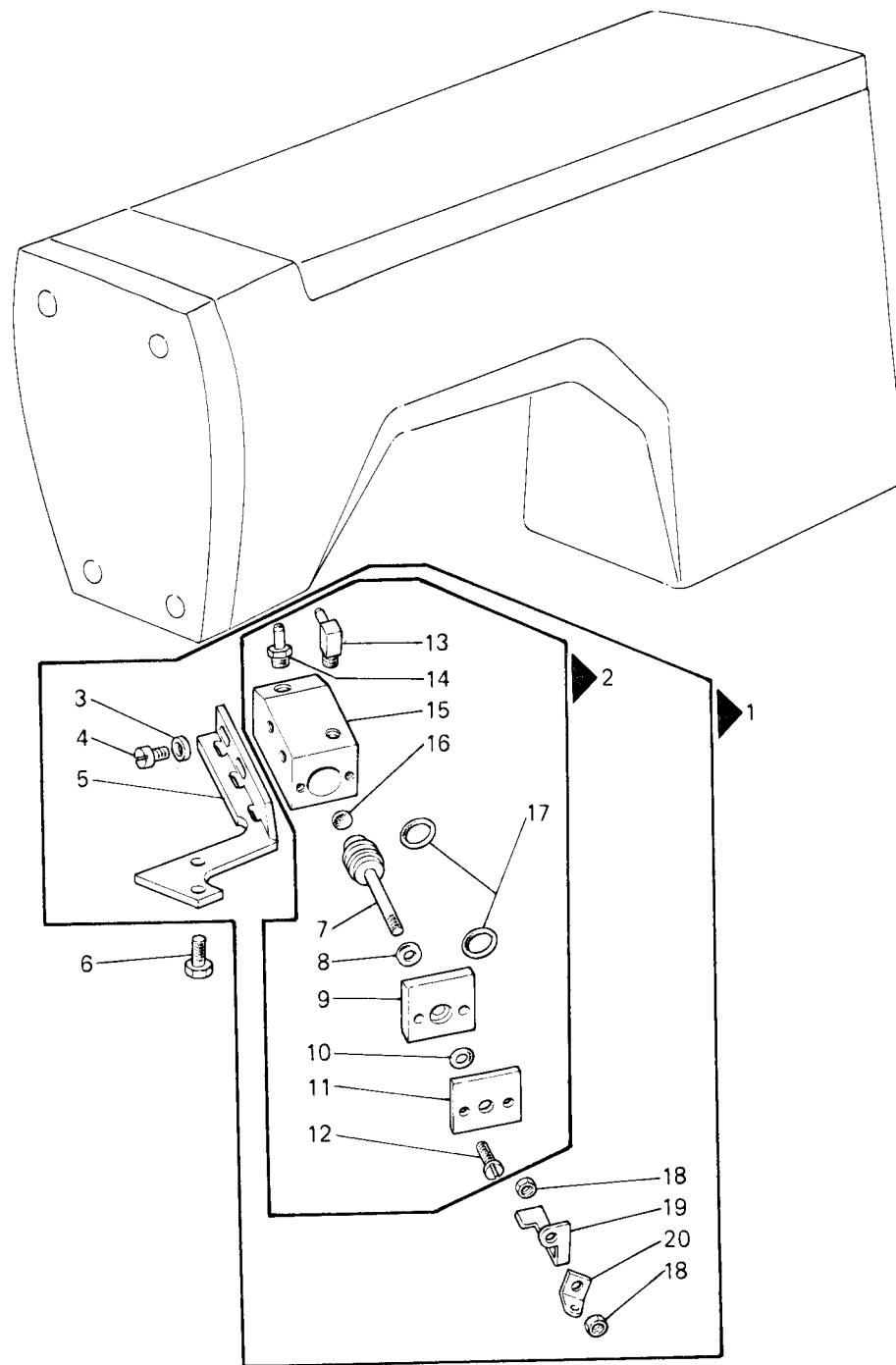
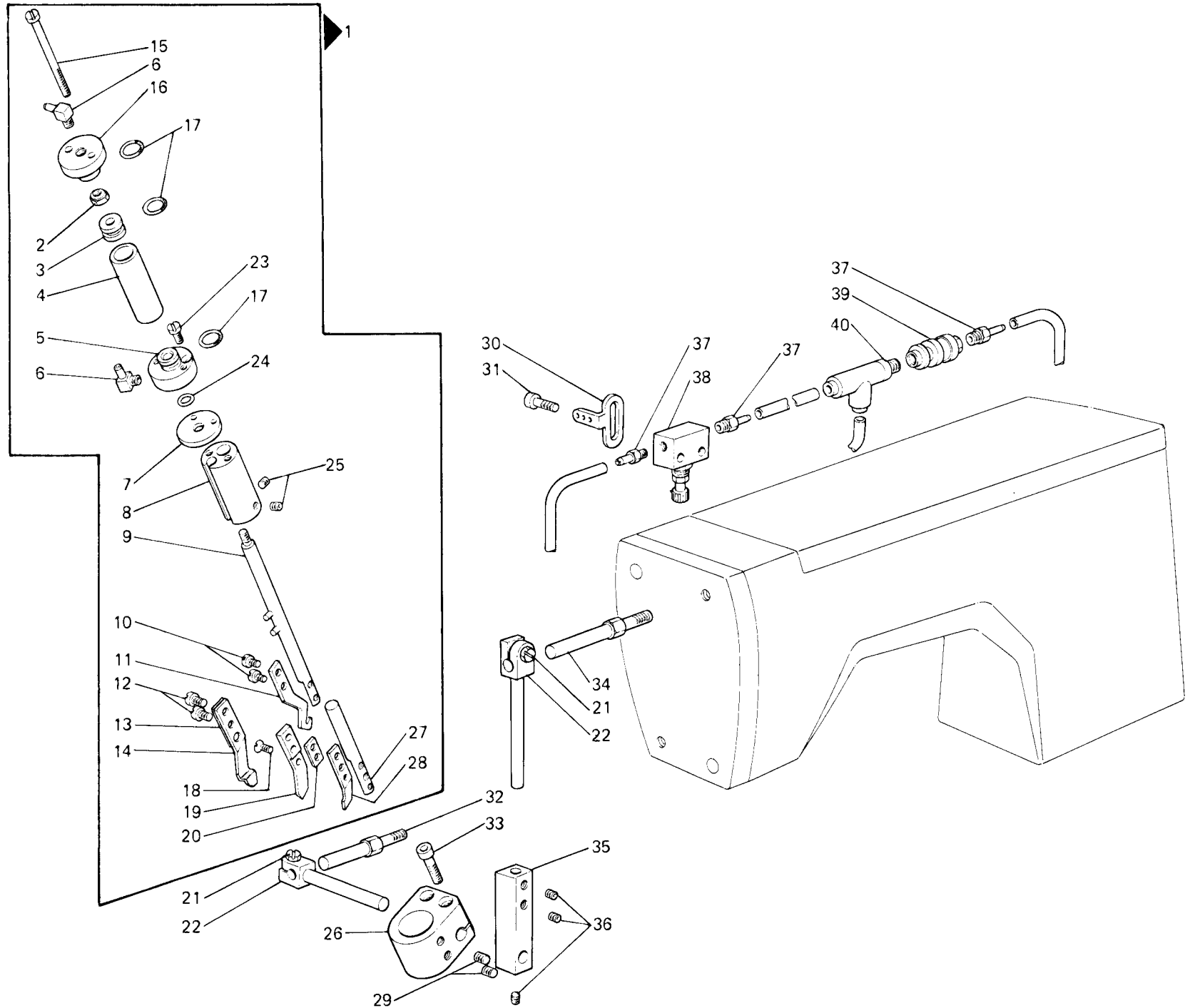

Fig. N.	Part. N. Piece N.	Qt.
1	932218-4-00	1
2	924030-4-00	1
3	704210-4-00	2
4	741936-2-00	2
5	932215-0-00	1
6	720453-2-00	2
7	924031-0-01	1
8	924731-0-20	1
9	924032-0-00	1
10	701003-0-00	1
11	924033-0-00	1
12	722070-2-00	2
13	943765-0-01	1
14	924701-0-11	1
15	924039-0-00	1
16	924045-0-00	1
17	701009-0-00	2
18	733505-2-00	2
19	924485-0-10	1
20	924484-0-10	1



# Rim® TAV. 7

Fig. N.	Part. N. / Piece N.	Qt.
1	932217-4-00	1
2	942787-0-00	1
3	932206-0-00	1
4	932201-0-00	1
5	932205-0-00	1
6	944821-0-00	2
7	932204-0-00	1
8	932202-0-00	1
9	932207-2-00	1
10	721412-2-00	2
11	932212-0-00	1
12	741675-2-00	2
13	932470-0-00	1
14	932214-0-00	1
15	721145-2-00	2
16	932203-0-00	1
17	701009-0-00	3
18	724420-5-00	1
19	932210-0-00	1
20	932216-0-00	1
21	740051-2-00	2
22	930432-2-10	2
23	722082-0-00	2
24	701005-0-00	1
25	745812-2-00	2
26	932209-2-00	1
27	932211-0-00	1
28	932213-0-00	1
29	729012-2-00	2
30	304243-0-10	1
31	722481-2-00	1
32	304107-0-10	1
33	722461-2-00	2
34	932228-0-00	1
35	932229-2-00	1
36	729013-2-00	3
37	944822-0-00	3
38	944446-0-00	1
39	932242-4-00	1
40	941522-4-00	1



	①	②	③	④	⑤
<b>METALWORK</b> COLORE ARANCIO ORANGE COLOUR COLEUR ORANGE	924245-4-00	924233-0-00	924244-4-00	924238-0-00	924239-4-00
<b>STAMPOTECNICA</b> COLORE NERO BLACK COLOUR COLEUR NOIRE	925199-4-00	701133-0-00	925198-4-00	925196-0-00	925197-4-00

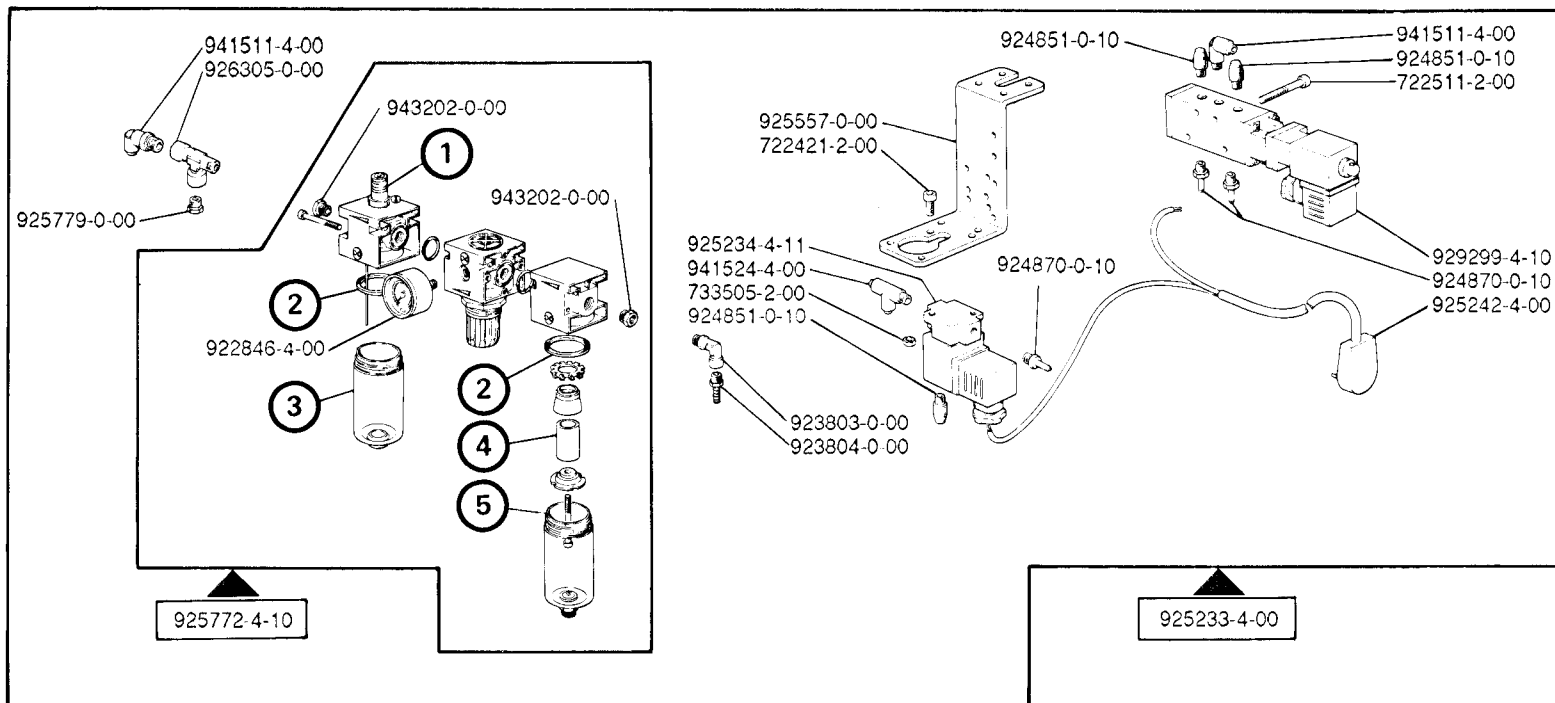

PER BANCALE REGOLABILE  
FOR ADJUSTABLE STAND  
POUR BATI REGLABLE

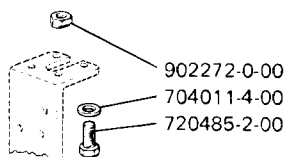

PER BANCALE A COLONNA  
FOR COLUMN STAND  
POUR BATI A COLONNE

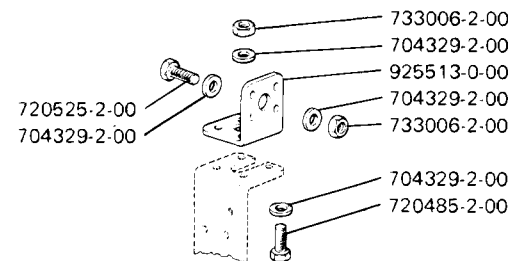

# Rim® TAV. 9

Fig. N.	Part. N. Piece N.	Qt.
1	924185-4-00	1
2	924188-4-00	1
3	924186-4-00	1
4	700205-0-00	1
5	924797-0-10	1
6	990310-0-10	1
7	746402-2-00	3
8	701007-0-00	1
9	924189-0-00	1
10	701033-0-00	1
11	924808-0-10	1
12	924187-0-00	1
13	701121-0-00	1
14	704218-2-00	1
15	924190-0-00	1
16	924191-0-00	1
17	700124-0-00	1
18	990311-0-10	1

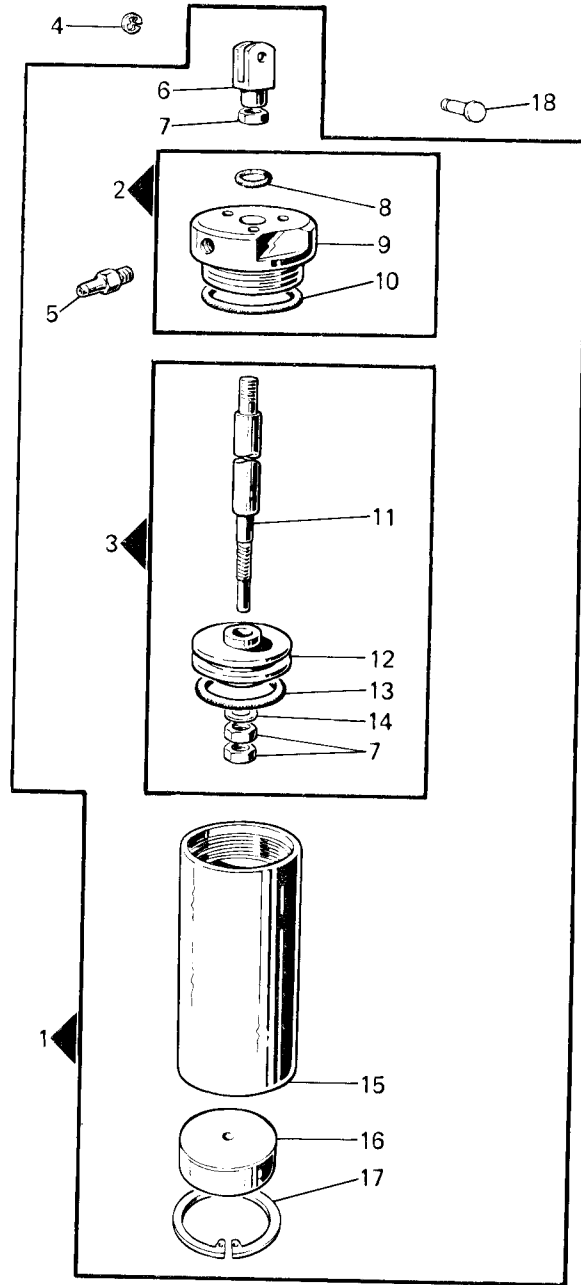

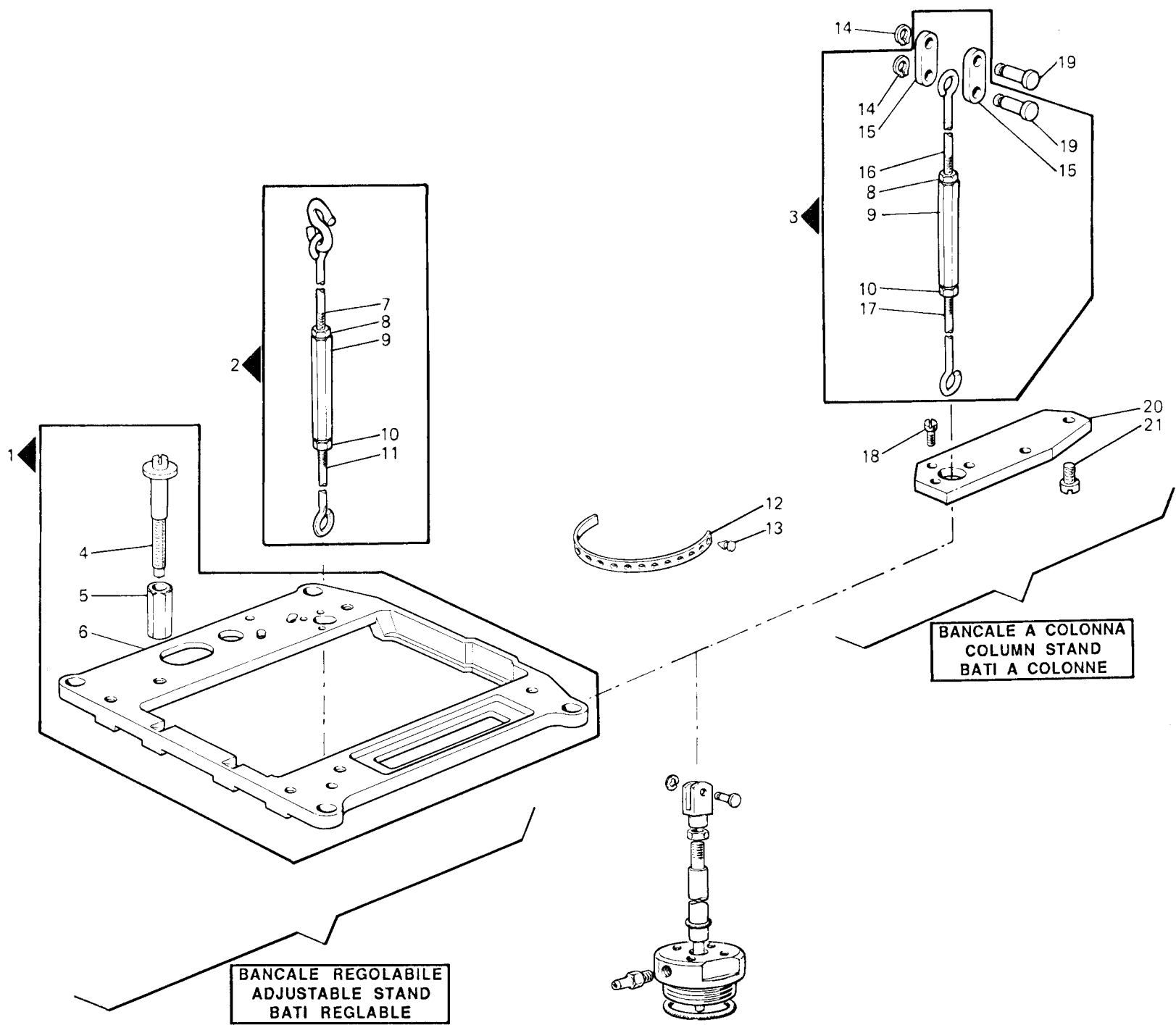
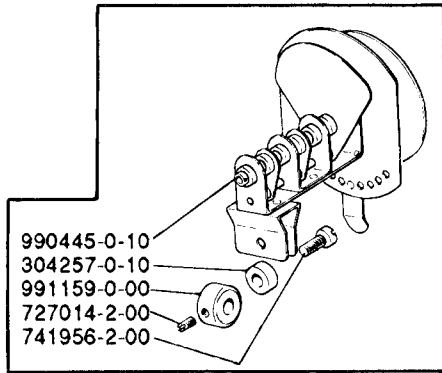

Fig. N.	Part N. Piece N.	Qt.
1	901228-4-00	1
2	901244-4-00	1
3	910214-4-11	1
4	901223-0-00	4
5	901224-0-00	4
6	901242-0-00	1
7	901217-2-00	1
8	733505-2-00	2
9	910190-0-10	2
10	746601-2-00	2
11	901243-0-00	1
12	990441-0-10	5
13	990442-0-10	5
14	700205-0-00	2
15	990765-0-00	2
16	910187-0-11	1
17	910213-0-10	1
18	721474-2-00	3
19	203211-0-10	2
20	990440-0-10	1
21	721484-2-00	2

173-10-3MD-01  
173-34-2MR-02



991158-4-00

A RICHIESTA  
ON REQUEST  
SUR DEMANDE

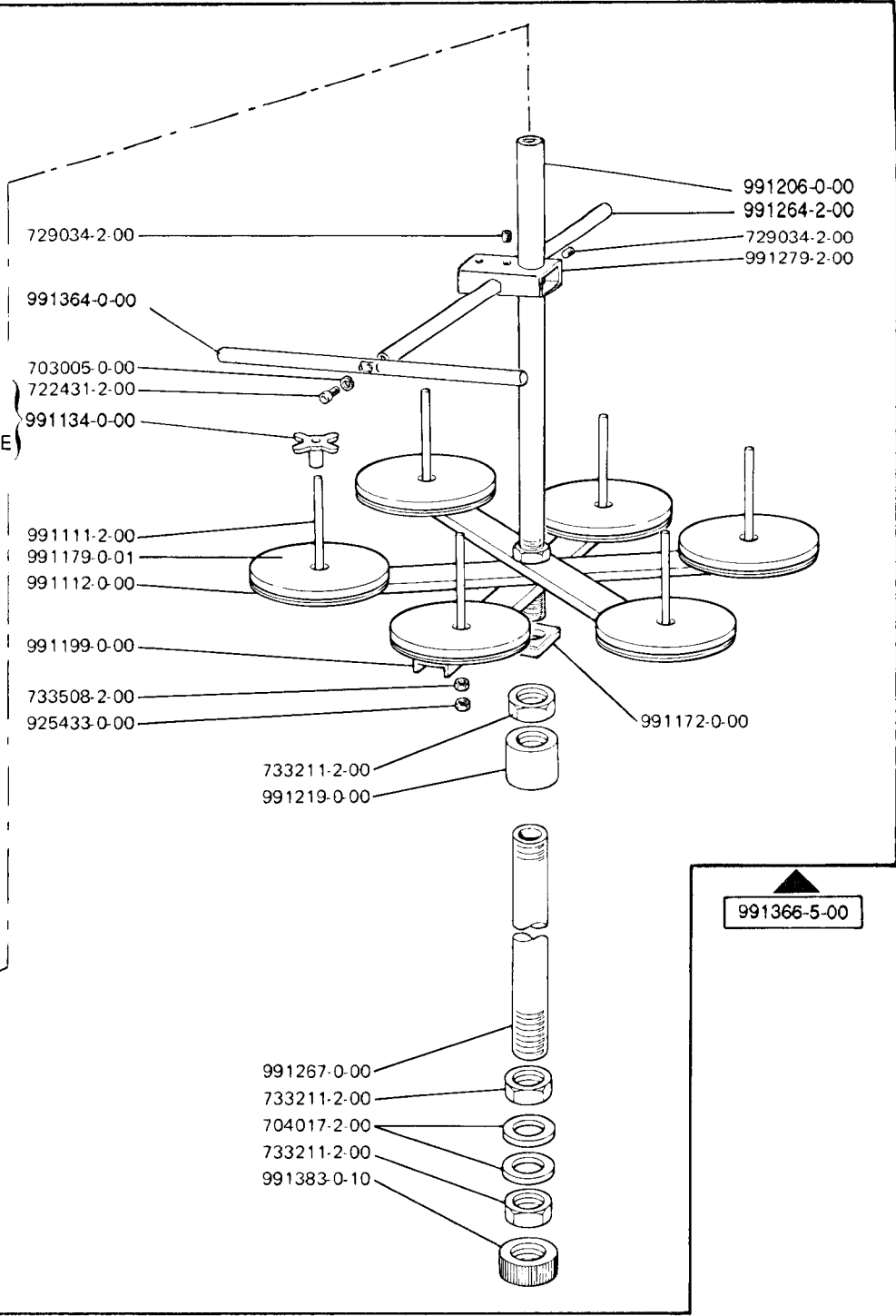

991366-5-00

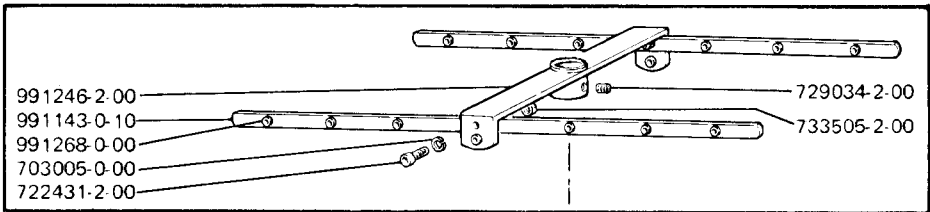

991193-4-00

173-10-2MD-01  
173-16-2MK-01

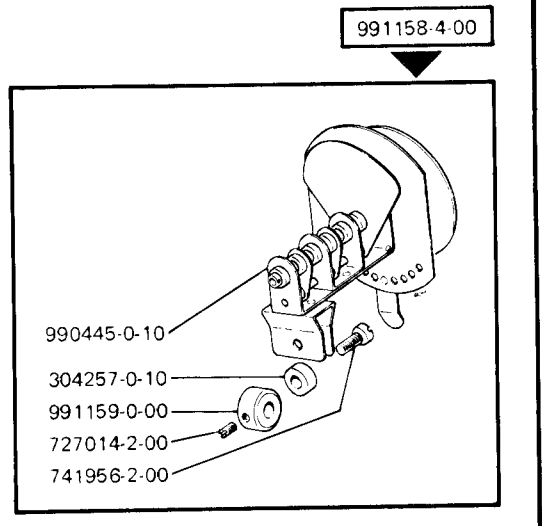

991158-4-00

991194-4-00

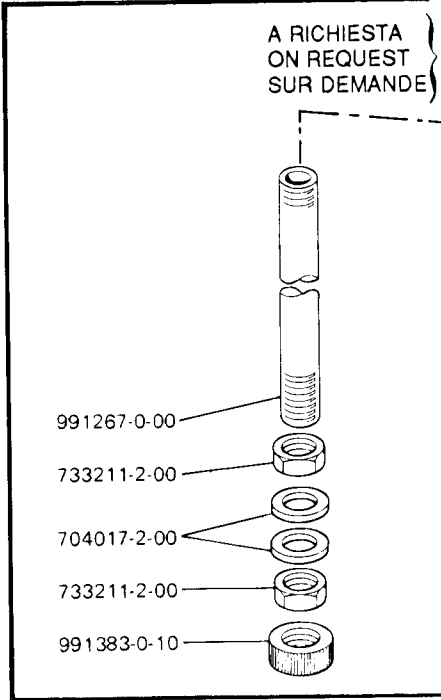
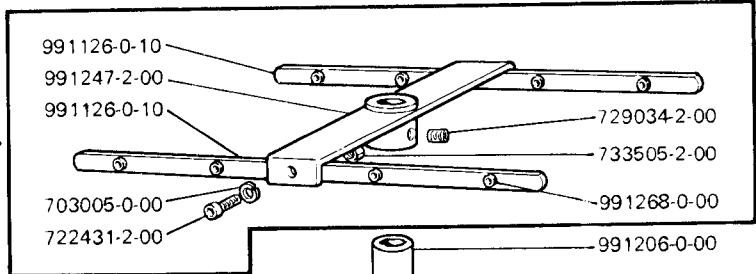

991134-0-00

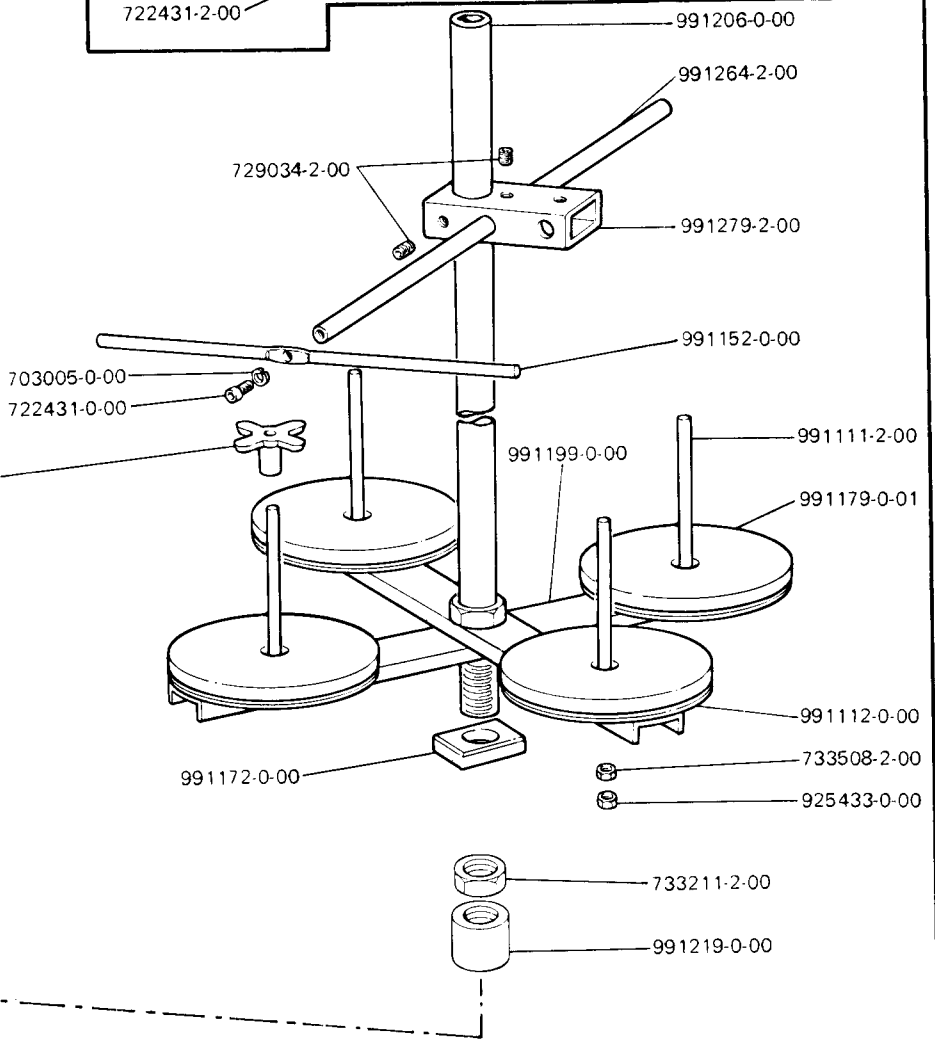

991155-5-02

# Rim® TAV. 13

Fig. N.	Part. N. Piece N.	Qt.
1	944764-2-00	1
2	920258-0-10	10
3	924480-0-00	1
4	944822-0-00	1
5	924701-0-11	11
6	944795-0-00	1
7	704310-2-00	1
8	703007-0-00	1
9	733507-2-00	1
10	722573-2-00	1
11	729012-2-00	1
12	707221-0-00	2
13	944950-0-00	1
14	704220-2-00	1
15	701104-0-00	3
16	724462-2-00	1
17	924497-0-00	1
18	927655-0-00	3
19	722431-2-00	1
20	944794-2-00	1

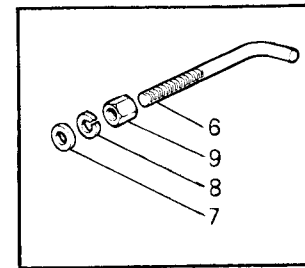
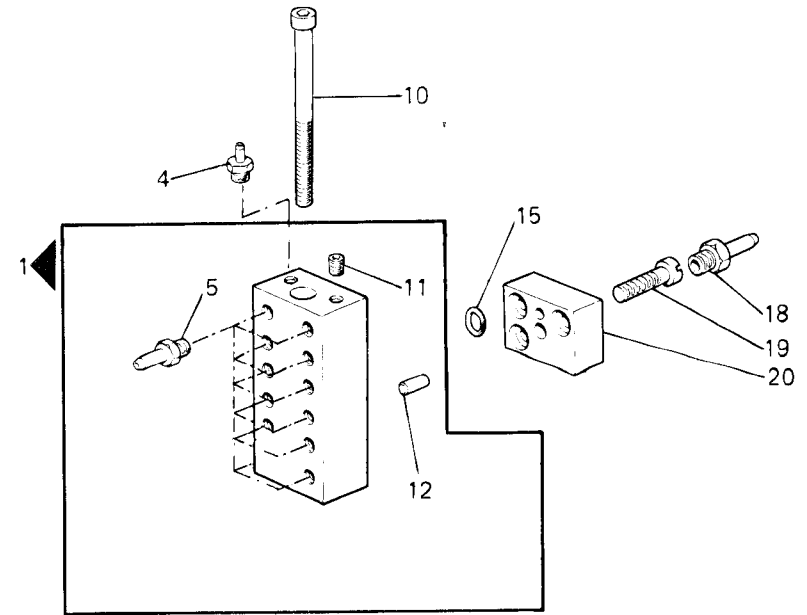
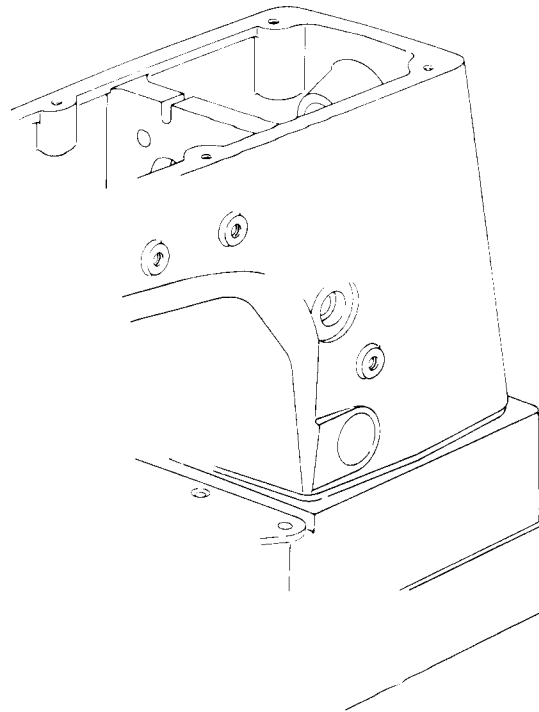

173-10-2MD-01  
173-10-3MD-01  
173-16-2MK-01

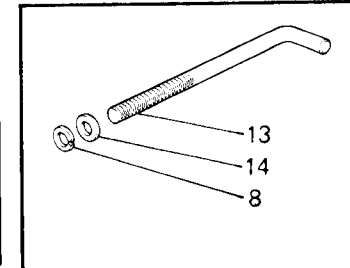

173-34-3MR-02

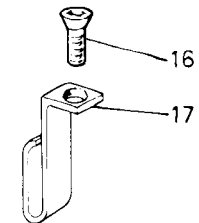
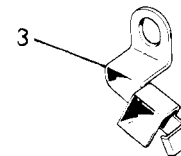
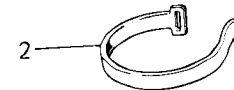

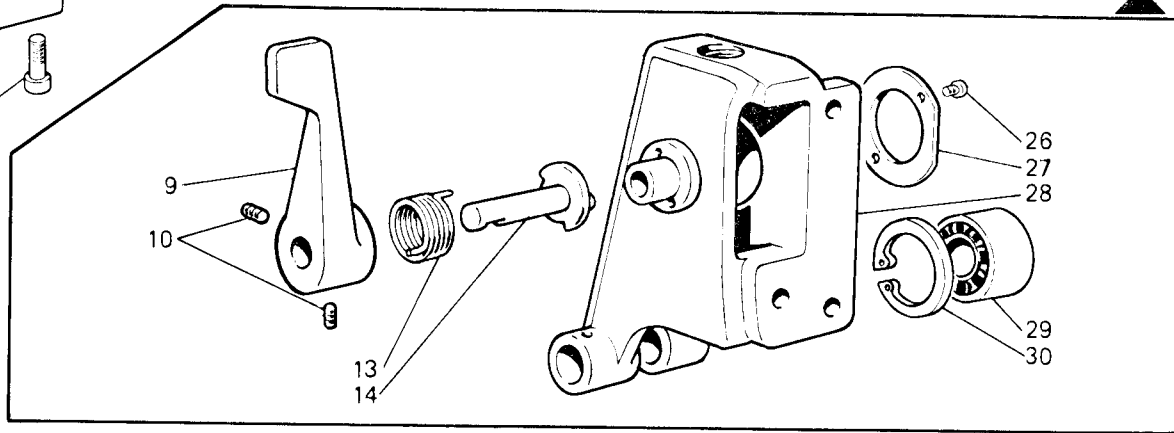
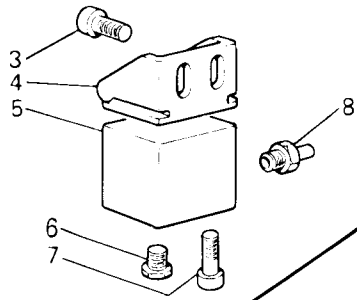

SOLO PER  
ONLY FOR  
SEULEMENT POUR

517-40

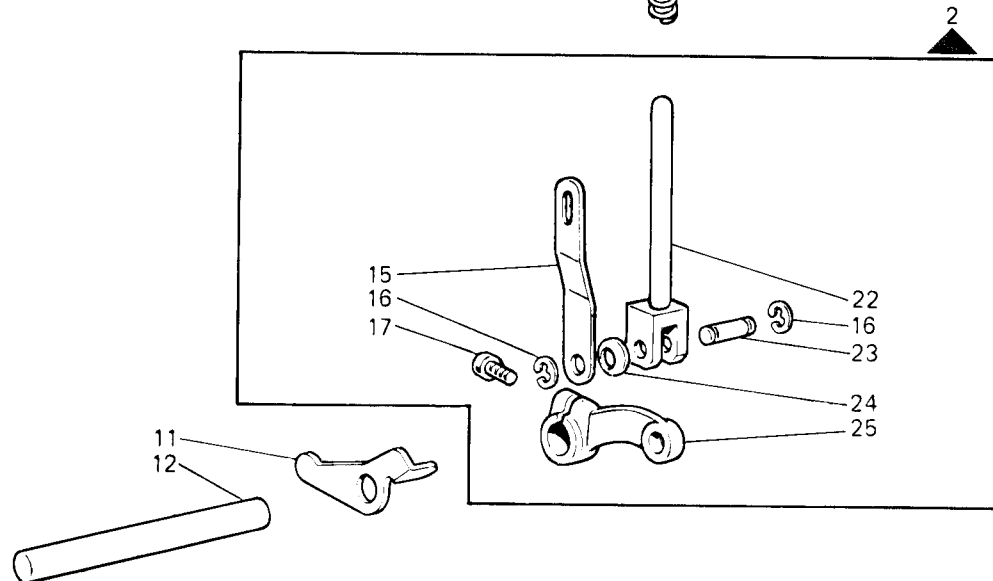
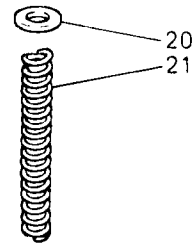

# Rim® TAV.14

Fig. N.	Part. N. Piece N.	Qt.
1	307597-4-00	1
2	307584-4-00	1
3	722422-2-00	2
4	922939-0-00	1
5	922942-4-00	1
6	944925-0-00	2
7	722492-2-00	1
8	924870-0-10	1
9	307616-2-00	1
10	729033-2-00	2
11	922938-0-00	1
12	307762-0-01	1
13	307701-0-00	1
14	307656-0-11	1
15	307615-0-10	1
16	700206-0-00	2
17	722432-2-00	1
18	722443-2-00	1
19	307705-0-00	1
20	704814-0-00	1
21	301510-0-10	1
22	307618-0-10	1
23	307617-0-10	1
24	307605-0-00	1
25	307612-2-10	1
26	721412-2-00	2
27	307640-0-00	1
28	311370-3-00	1
29	307639-0-00	1
30	700131-0-00	1



# Rim <sup>3</sup>TAV. 15

Fig. N.	Part. N. / Piece N.	Qt.
1	926661-4-00	1
2	924735-4-12	1
3	729012-2-00	2
4	302284-2-10	1
5	701405-0-00	2
6	308512-0-00	2
7	308506-0-00	3
8	926416-0-00	1
9	926657-0-00	1
10	744676-2-00	2
11	308501-0-01	3
12	308503-0-01	3
13	308518-4-00	2
14	308505-0-00	3
15	300218-0-10	6
16	308507-0-00	3
17	202556-0-01	3
18	200710-0-10	2
19	202229-0-11	3
20	202558-0-00	3
21	200714-0-10	1
22	308521-4-00	1
23	741495-0-00	4
24	745800-2-00	1
25	924739-0-10	1
26	924745-0-20	1
27	926669-4-01	1
28	701009-0-00	2
29	700205-0-00	1
30	924740-0-10	1
31	202100-0-10	1
32	701104-0-00	1
33	924738-4-21	1
34	924701-0-11	2
35	924734-0-20	1
36	721086-2-00	2

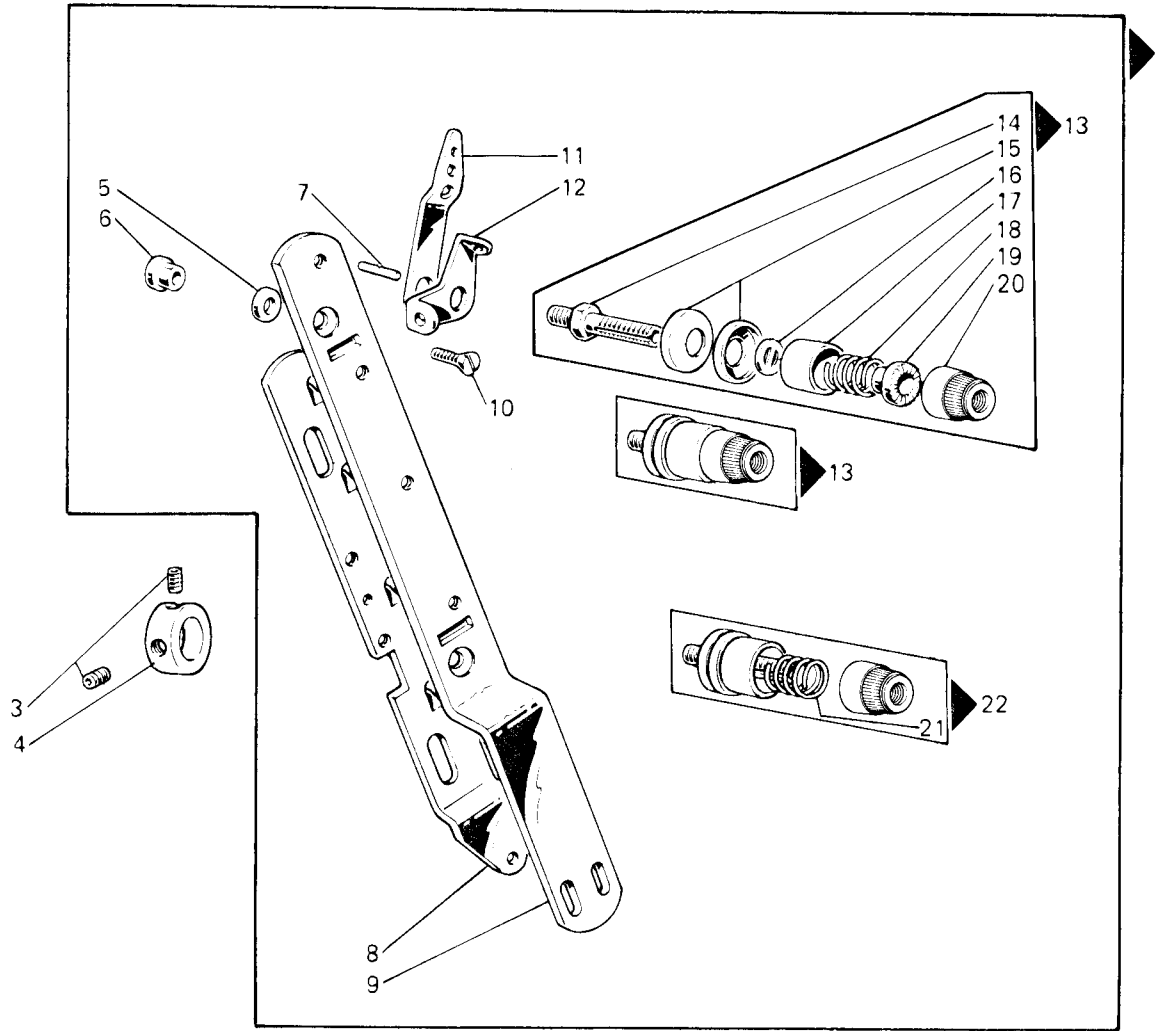

173-10-2MD-01  
173-16-2MK-01

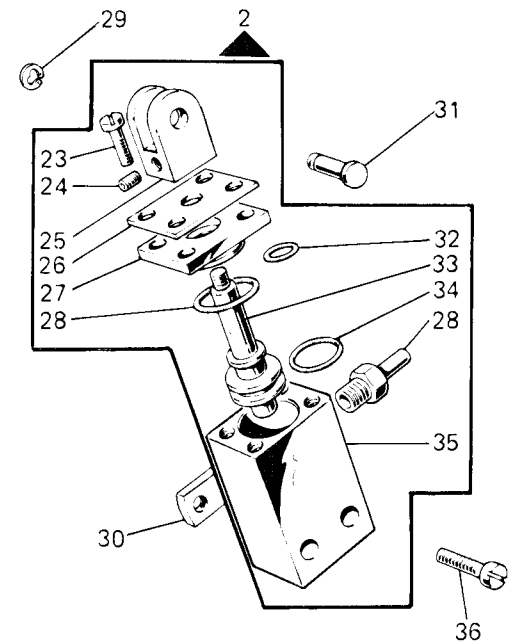

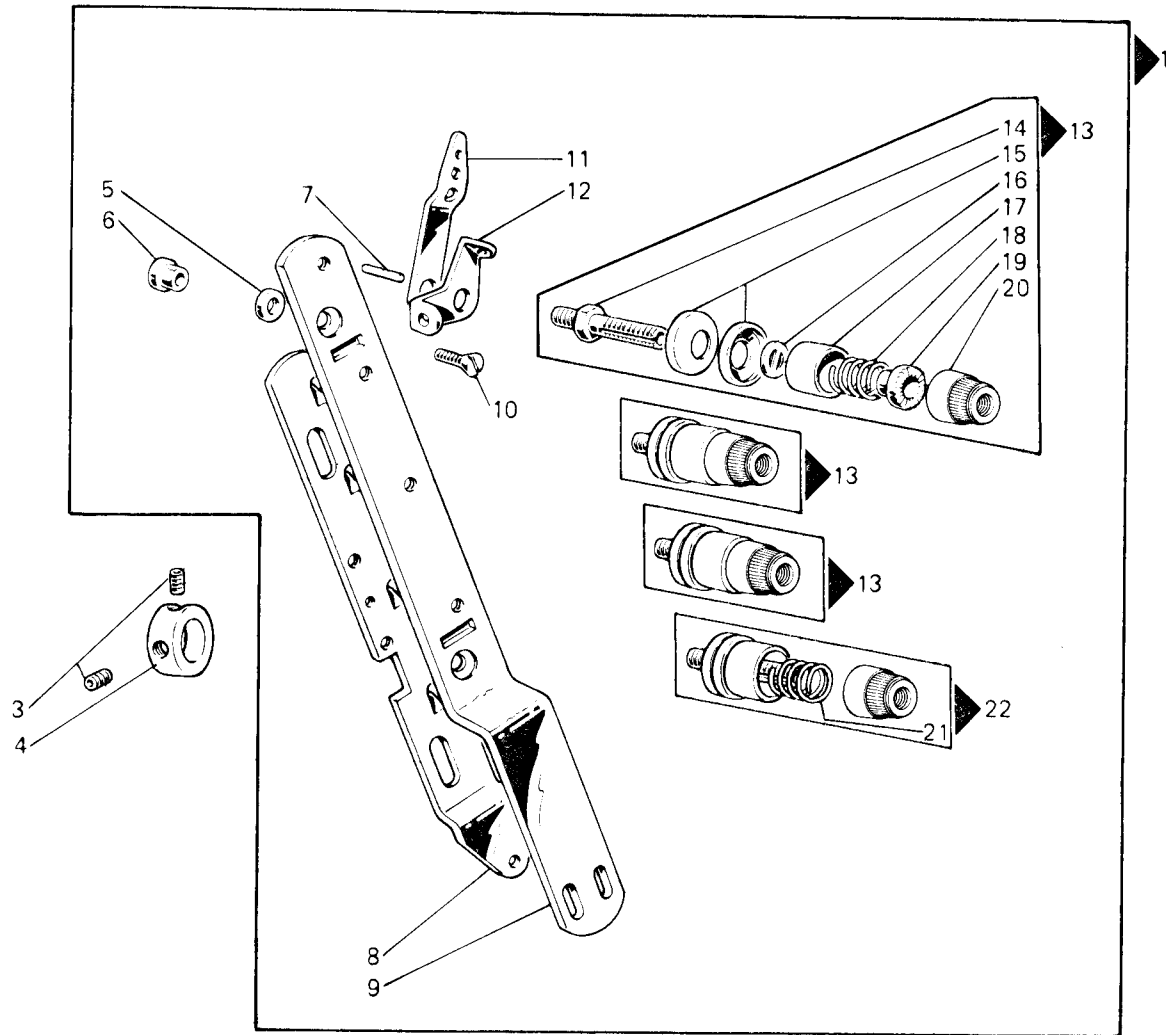

173-10-3MD-01  
173-34-2MR-02

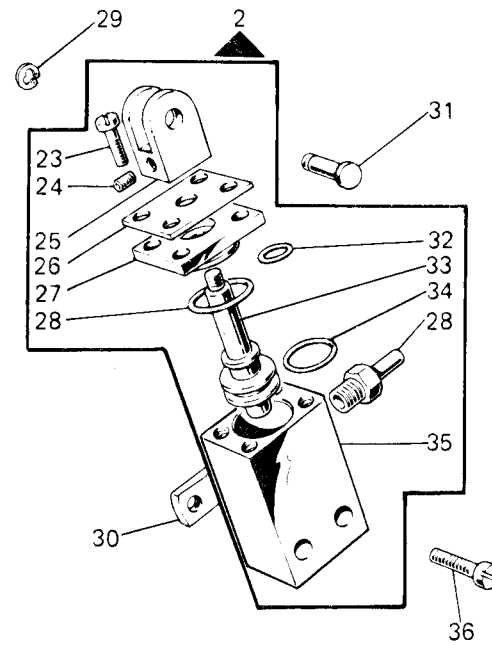

### Rim<sup>®</sup> TAV. 16

Fig. N.	Part. N. Piece N.	Qt.
1	926660-4-00	1
2	924735-4-12	1
3	729012-2-00	2
4	302284-2-10	1
5	701405-0-00	2
6	308512-0-00	2
7	308506-0-00	4
8	926416-0-00	1
9	926657-0-00	1
10	744676-2-00	2
11	308501-0-01	4
12	308503-0-01	4
13	308518-4-00	3
14	308505-0-00	4
15	300218-0-10	8
16	308507-0-00	4
17	202556-0-01	4
18	200710-0-10	3
19	202229-0-11	4
20	202558-0-00	4
21	200714-0-10	1
22	308521-4-00	1
23	741495-0-00	4
24	745800-2-00	1
25	924739-0-10	1
26	924745-0-20	1
27	926669-4-01	1
28	701009-0-00	2
29	700205-0-00	1
30	924740-0-10	1
31	202100-0-10	1
32	701104-0-00	1
33	924738-4-21	1
34	924701-0-11	2
35	924734-0-20	1
36	721086-2-00	2

# Rim® TAV.17

Fig. N.	Part. N. Piece N.	Qt.
1	924405-4-00	1
2	741974-2-00	3
3	302247-0-10	1
4	924365-0-00	1

	(A)	(B)	(C)
<b>173-10-2MD-01</b>	924467-0-00	924474-0-00	924465-0-00
<b>173-10-3MD-01</b>	924467-0-00	924474-0-00	924465-0-00
<b>173-16-2MK-01</b>	924475-0-00	924474-0-00	924433-0-00
<b>173-34-3MR-02</b>	924467-0-00	---	---

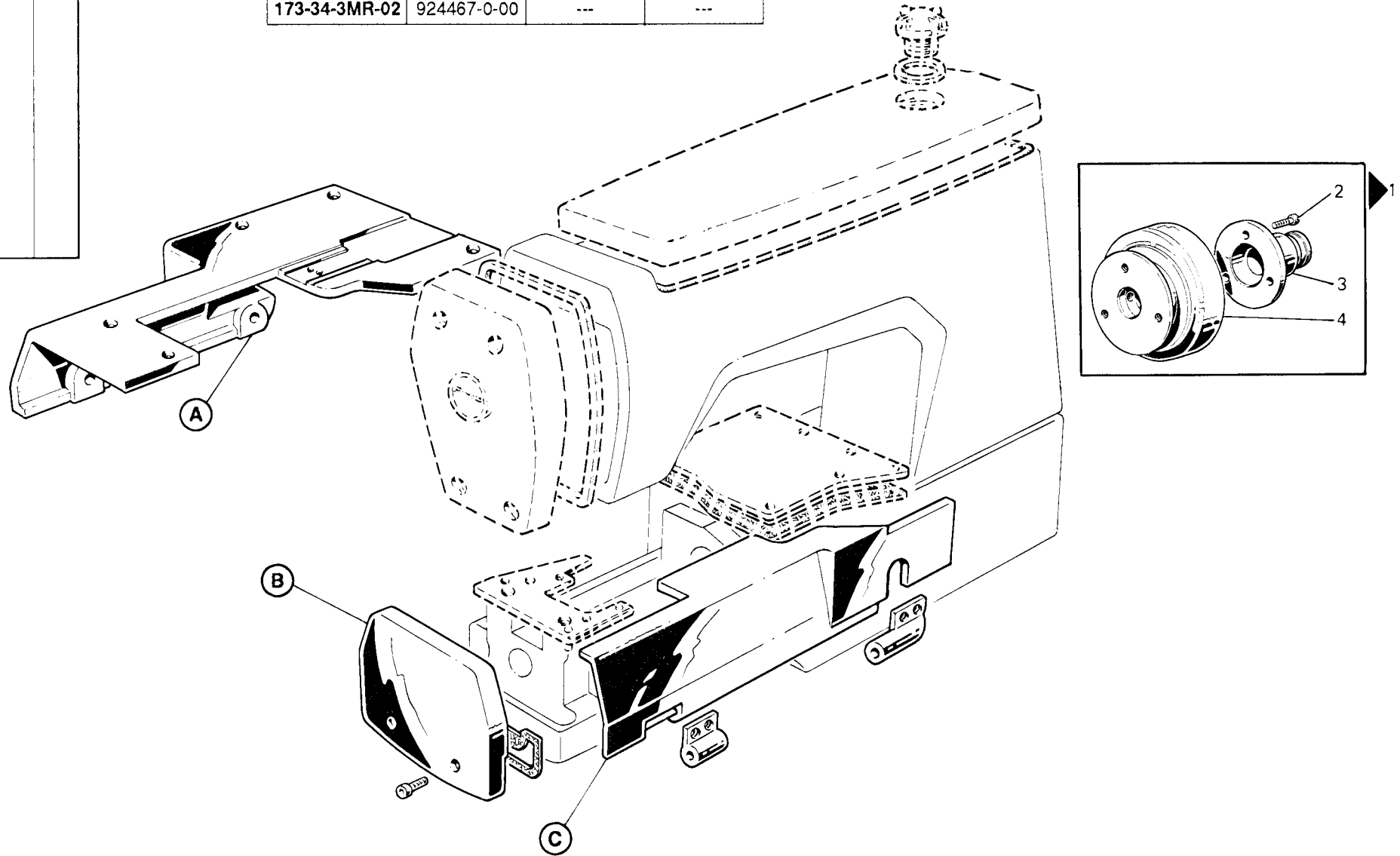

173-10-2MD-01

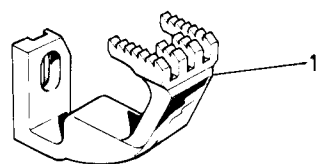

173-34-3MR-02

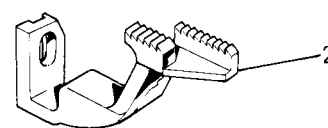

173-10-3MD-01

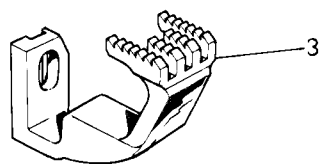

173-16-2MK-01

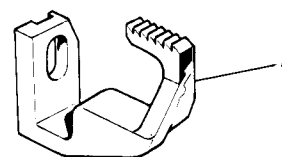

Fig. N.	Part. N. Piece N.	Qt.
1	924509-0-11	1
2	924534-0-01	1
3	924539-0-11	1
4	924551-0-11	1

SOLO I PEZZI DI RICAMBIO ORIGINALI RIMOLDI MARCATI **Rim** GARANTISCONO EFFETTIVA INTERCAMBIABILITA' FUNZIONALITA', DURATA.

RIMOLDI ORIGINAL SPARE PARTS MARKED **Rim** ARE THE ONLY ONES WHICH GUARANTEE INTERCHANGEABILITY, FUNCTIONALITY, AND LONG MACHINE LIFE

EXCLUSIVEMENT LES PIECES DE RECHANGE ORIGINALES RIMOLDI MARQUEES **Rim** GARANTISSENT UNE INTERCHANGEABILITE, UN CARACTERE FONCTIONNEL, UNE DUREE EFFECTIFS.

NUR DIE MIT **Rim** MARKIERTEN RIMOLDI-ORIGINALERSATZTEILE GARANTIEREN EINE EFFEKTIVE AUSTAUSCHBARKEIT, ZWECKENTSPRECHENDHEIT, LEBENSDAUER.

SOLO EL EMPLEO EXCLUSIVO DE REPUESTOS RIMOLDI MARCADOS **Rim** ASEGURAN LA CALIDAD DE INTERCAMBIABILIDAD, LA FUNCIONALIDAD Y LA DURACION.

La Rimoldi S.r.l. si riserva il diritto di modificare o variare, per motivi di ordine tecnico o commerciale, i dati riportati nella presente pubblicazione.

Rimoldi S.r.l. reserves the right to modify or vary, for technical or commercial reasons, the information printed in this brochure.

Rimoldi S.r.l. se réserve le droit de modifier ou changer les données établies sur la présente publication pour tous motifs d'ordre technique ou commercial.

Rimoldi S.r.l. kann jederzeit aus technischen oder kommerziellen Gründen Änderungen an den in diesem Heft beschriebenen Erzeugnissen vornehmen.

Rimoldi S.r.l. se reserva el derecho de modificar o variar, por motivos técnicos o comerciales, los datos aquí publicados.

DIRITTI RISERVATI: Nessuna riproduzione è permessa senza previa autorizzazione scritta della Rimoldi S.r.l.

ALL RIGHTS RESERVED: Reproduction in whole or in part is forbidden unless expressly authorized in writing by Rimoldi S.r.l.

DROIT RESERVES: Toute reproduction est interdite sans autorisation préalable écrite de Rimoldi S.r.l.

DERECHOS RESERVADOS: Se prohíbe la reproducción total o parcial sin previa autorización escrita de Rimoldi S.r.l.

VORBEHALTENE RECHTE: Keinerlei Wiedergabe ist ohne vorausgehender schriftlicher Genehmigung seitens der Rimoldi S.r.l. gestattet.