

# Rimoldi®

CATALOGO PEZZI DI RICAMBIO Rim®

Rim® SPARE PARTS CATALOGUE

CATALOGUE RECHANGES Rim®

627-41-1CS-01

1a EDIZIONE-EDITION 3/89

**n. 382**

## ISTRUZIONI PER LA CONSULTAZIONE DEL CATALOGO

- Tutti i particolari delle teste sono rappresentati in più tavole come indicato nell'indice.
- I particolari sono esplosi nelle stesse posizioni in cui si trovano nelle teste.
- Le linee tratteggiate indicano i collegamenti tra i pezzi che per ragioni di disegno o di spazio non possono essere illustrati nello stesso asse.
- I simboli racchiusi da un riquadro (es. xxxxxx-x-xx ) si riferiscono sempre a gruppi o sottogruppi.
- Nella rappresentazione grafica i componenti dei gruppi sono racchiusi da un riquadro; i componenti dei sottogruppi sono anch'essi riquadrati all'interno del gruppo.

## TAVOLE CON PARTICOLARI COMUNI A TUTTE LE TESTE

- I simboli dei particolari o dei gruppi si leggono direttamente in corrispondenza dei pezzi.

## TAVOLE CON PARTICOLARI NON COMUNI A TUTTE LE TESTE

- I simboli dei particolari o dei gruppi si leggono direttamente in corrispondenza dei pezzi.
- I particolari specifici per le singole teste sono indicati nel disegno con un numero progressivo evidenziato da un cerchio per i pezzi singoli o piccoli gruppi e da un quadrato per i gruppi principali. Per ricercare il simbolo del pezzo e del gruppo occorre consultare la relativa tabella riportata nella stessa tavola.

## TAVOLE DOPPIE

- Per facilitare la consultazione alcune tavole sono state duplicate e sono indicate con lo stesso numero affiancato da una lettera (es. 3/A - 3/B).

## ORGANI DI CUCITURA - GUIDE - ACCESSORI VARI

- Gli organi di cucitura — le guide — gli accessori vari sono preceduti da tavole riepilogative con l'indicazione dei particolari in dotazione e a richiesta.

## AGHI

- Gli aghi sono contraddistinti dal sistema e dalla finezza. Il sistema dell'ago e la finezza sono marcati oltre che sulla busta, anche sull'ago stesso. Nelle ordinazioni precisare, oltre al simbolo, il sistema e la finezza degli aghi desiderati. In caso di dubbio allegare un ago campione o una busta vuota.

## INSTRUCTION TO CONSULT THE CATALOGUE

- All the spare parts are illustrated in several tables as indicated in the index.
- The parts are illustrated as they belong together in the machine
- The dashed illustration shows where the adjacent parts belong
- The symbols included in a square (e.g. xxxxxx-x-xx ) are always referred to assemblies or sub-assemblies.
- In the graphical representation the components belonging to sub-assemblies are also included in a square within their assembly.

## TABLES WITH PARTS COMMON TO ALL HEADS

- The symbols of the parts or of the assemblies can be read in direct reference to the parts.

## TABLE WITH PARTS NOT COMMON TO ALL HEADS

- The symbols of the parts or of the assemblies can be read in direct reference to the parts.
- In the drawing the specific parts for the single heads are indicated by a progressive figure which is made evident by a circle for the single parts or small assemblies and by a square for the main assemblies. The symbol of the part or of the assembly can be located by consulting the relevant part-list included in the same table.

## DOUBLE TABLES

- For easier reference, some tables have been duplicated. They are indicated by the same figure plus an additional letter, (e.g. 3/A and 3/B)

## SEWING PARTS - FOLDERS - VARIOUS ACCESSORIES

- Sewing parts, folders and various accessories are preceded by summary tables indicating standard parts supplied and parts supplied on request.

## NEEDLE

- The needles are marked with system and size. The system and size of the needle are shown on the packet as well as on the needle itself. When ordering please state symbol, system and size. If you have doubts, enclose a sample needle or an empty packet with your order.

## INSTRUCTION POUR LA CONSULTATION DU CATALOGUE

- Toutes les pièces des têtes sont représentées en plusieurs tables comme nous avons indiqué dans l'index.
- Les pièces figurent sur l'illustration comme elles vont ensemble
- Les figures en tirets montrent le lieu de montage des pièces figurant à côté.
- Les symboles compris entre panneaux (ex. xxxxxx-x-xx ) se réfèrent toujours à des groupes ou sous-groupes.
- Dans la représentation graphique les composants des sous-groupes sont eux-mêmes encadrés à l'intérieur du groupe.

## TABLES AVEC COMPOSANTS COMMUNS A TOUTES LES TÊTES

- Les symboles des composants et des groupes se lisent directement en correspondance des pièces.

## TABLES AVEC COMPOSANTS NON COMMUNS A TOUTES LES TÊTES

- Les symboles des composants et des groupes se lisent directement en correspondance des pièces.
- Les composants spécifiques de chaque tête sont indiqués sur les dessins avec un numéro progressif encerclé pour les simples composants ou petits groupes et numéro encadré pour les groupes principaux. Pour chercher le symbole de la pièce ou du groupe il faut consulter la relative fiche reportée sur la même table.

## TABLE DOUBLE

- Pour faciliter la consultation certaines tables ont été doublées et sont indiquées avec le même numéro suivi par une lettre (ex. 3/A - 3/B)

## ORGANES DE COUTURES - GUIDES - ACCESSOIRES DIVERS

- Les organes de coutures - les guides - les divers accessoires sont précédés de tables résumés avec l'indication des composants en dotation et sur demande.

## AIGUILLES

- Les aiguilles se différencient par le système et la grosseur. Le système de l'aiguille et sa grosseur, sont indiqués non seulement sur le sachet mais également sur l'aiguille. Dans l'ordre précis, en plus du symbole, le système et la grosseur des aiguilles désirés. En cas de doute, joindre une aiguille comme modèle ou un sachet vide.



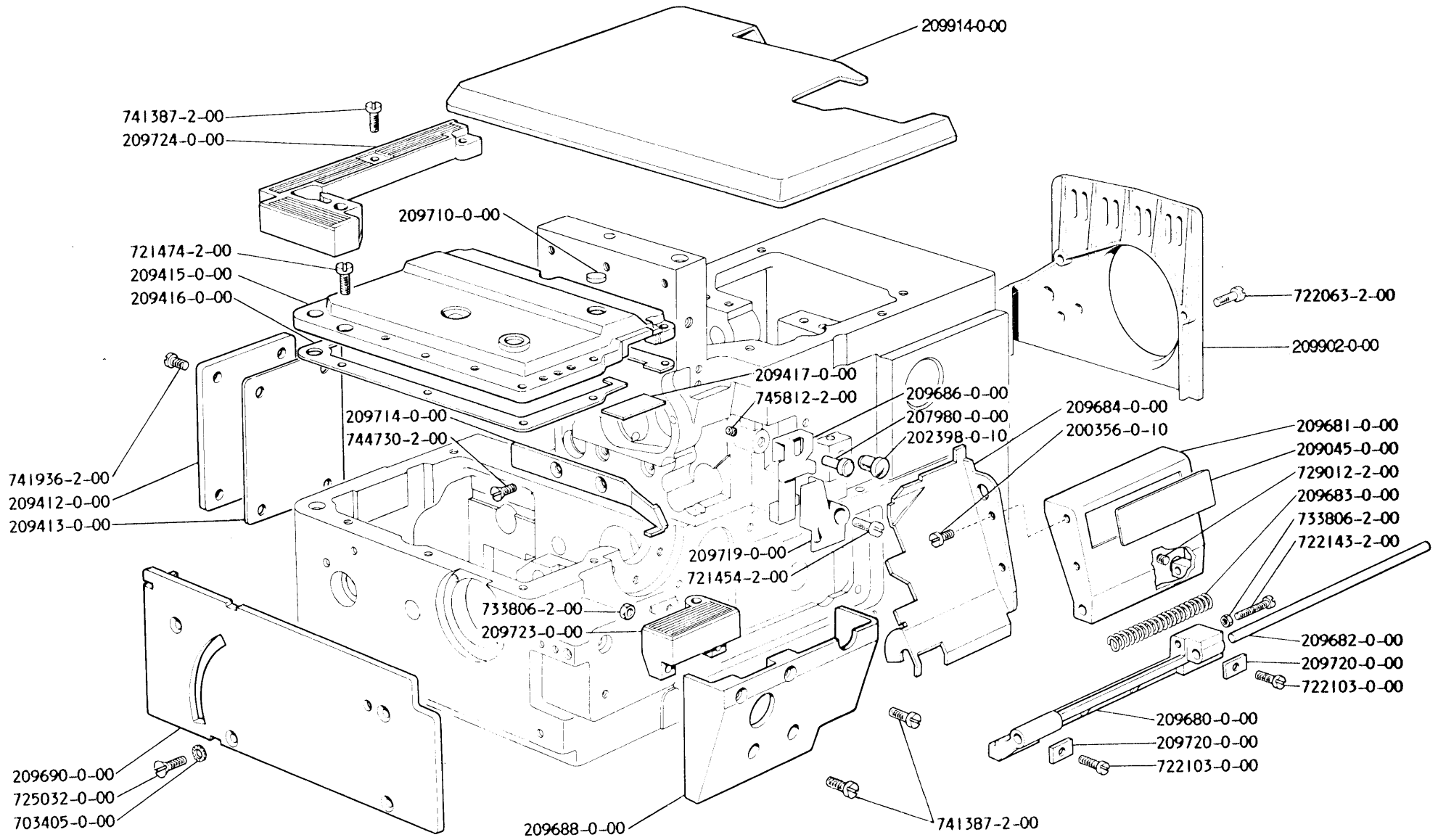

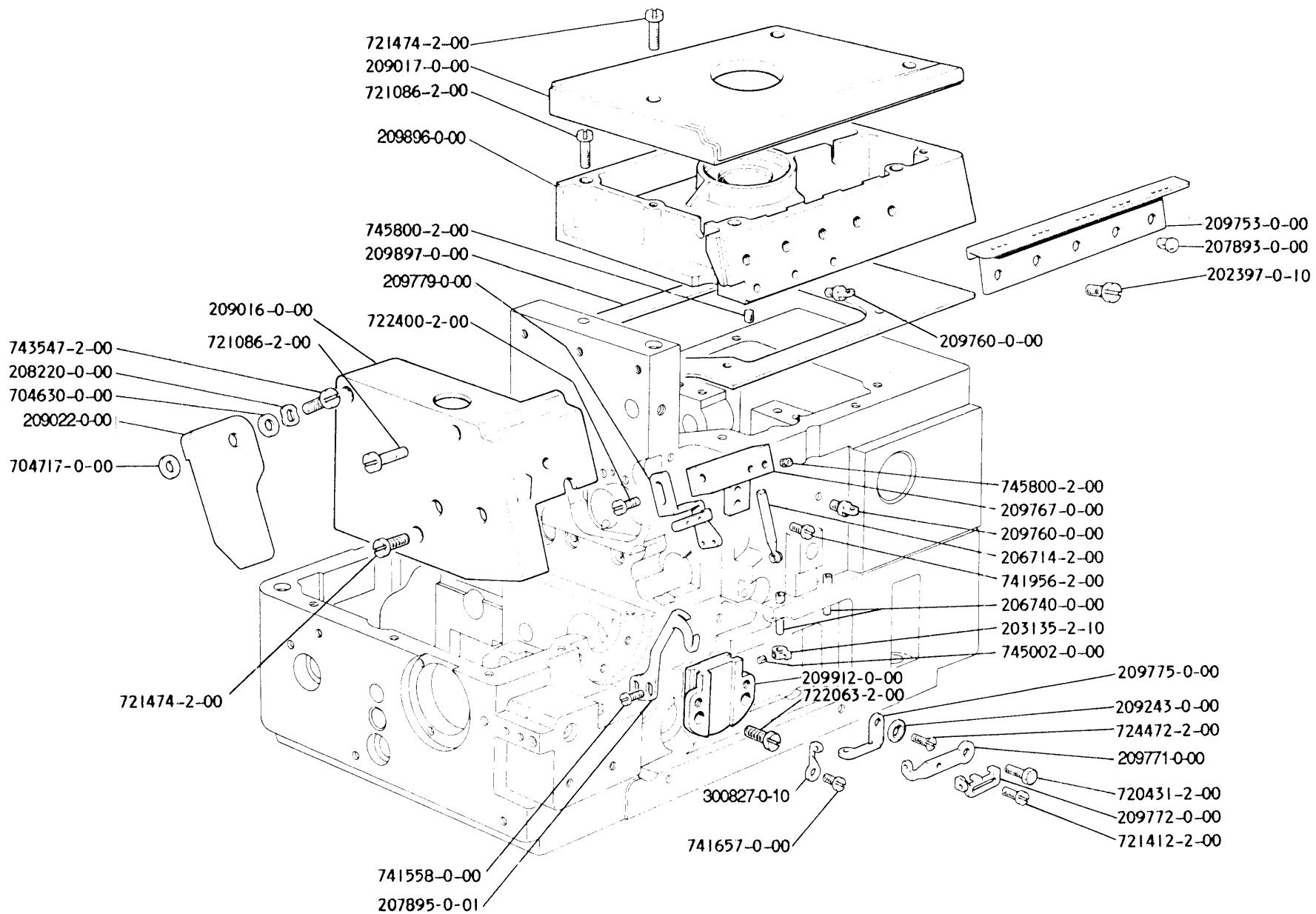

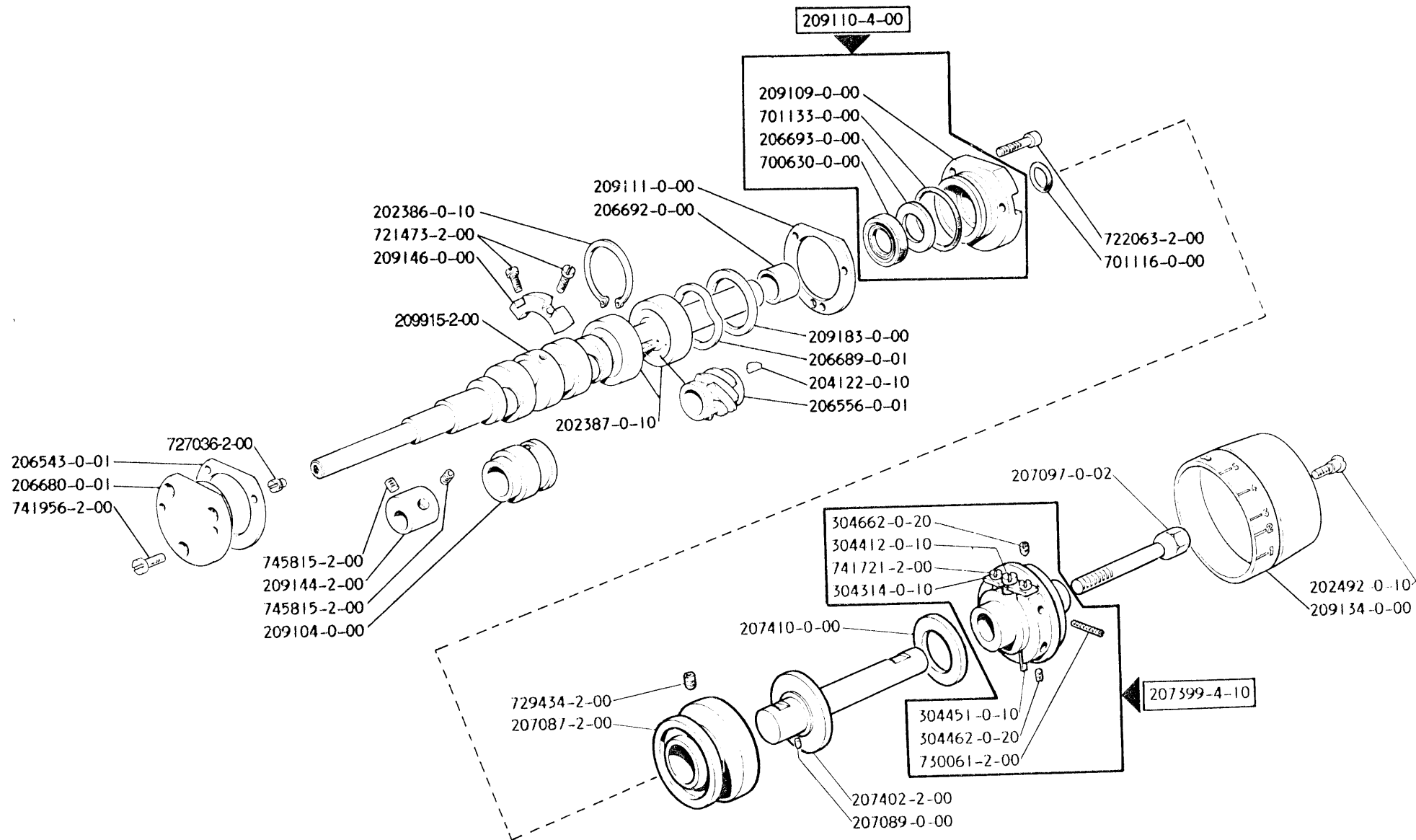

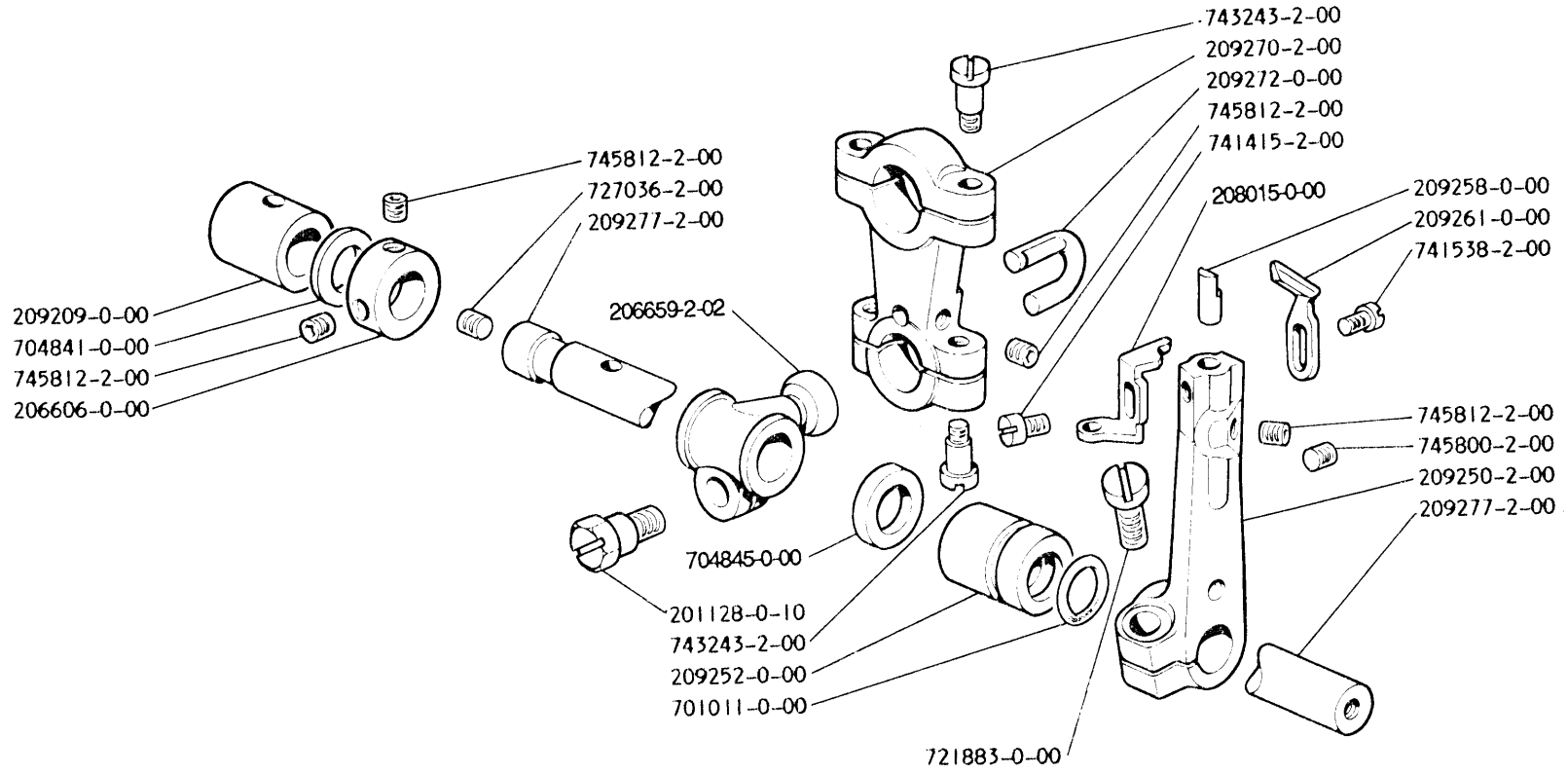

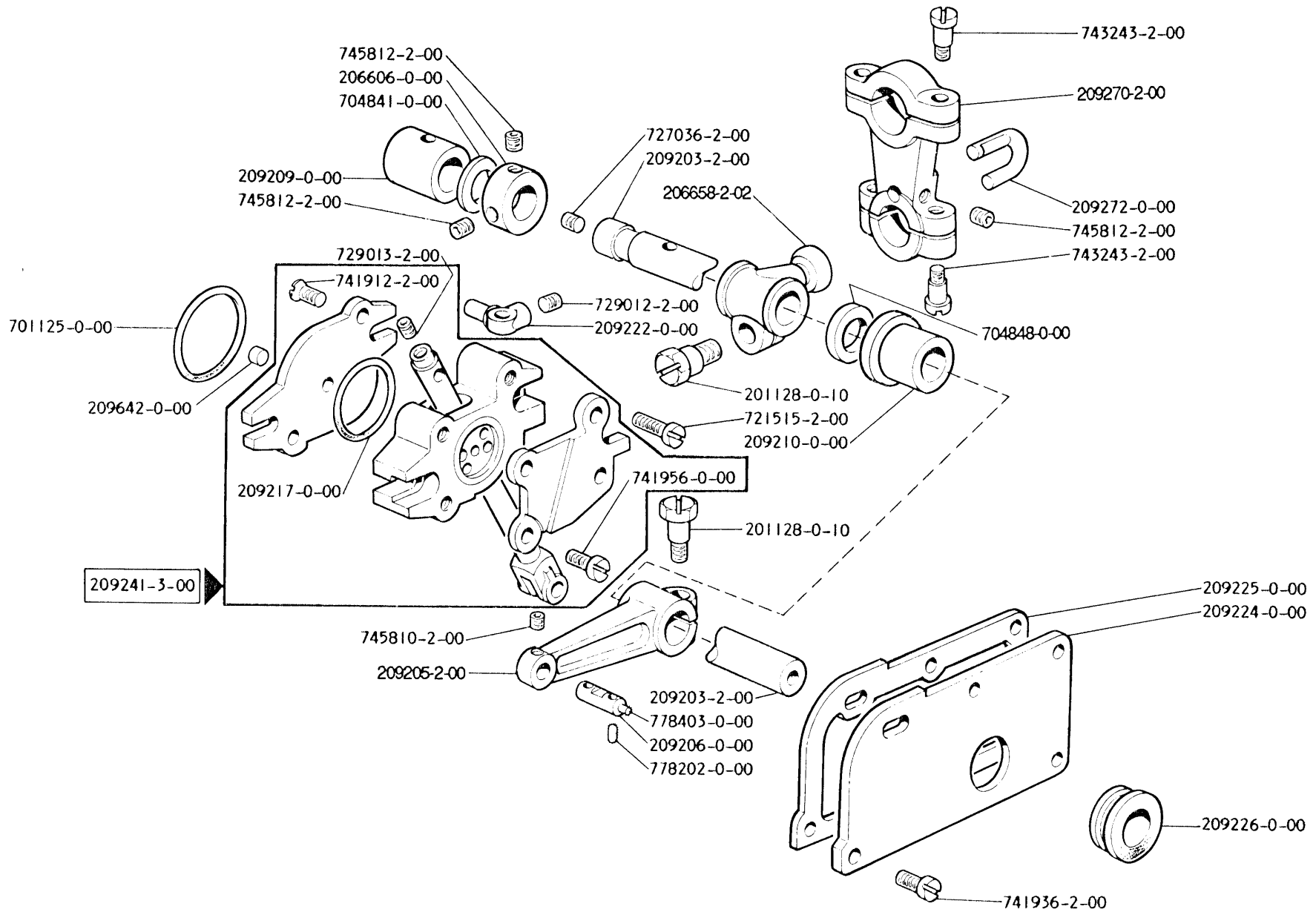



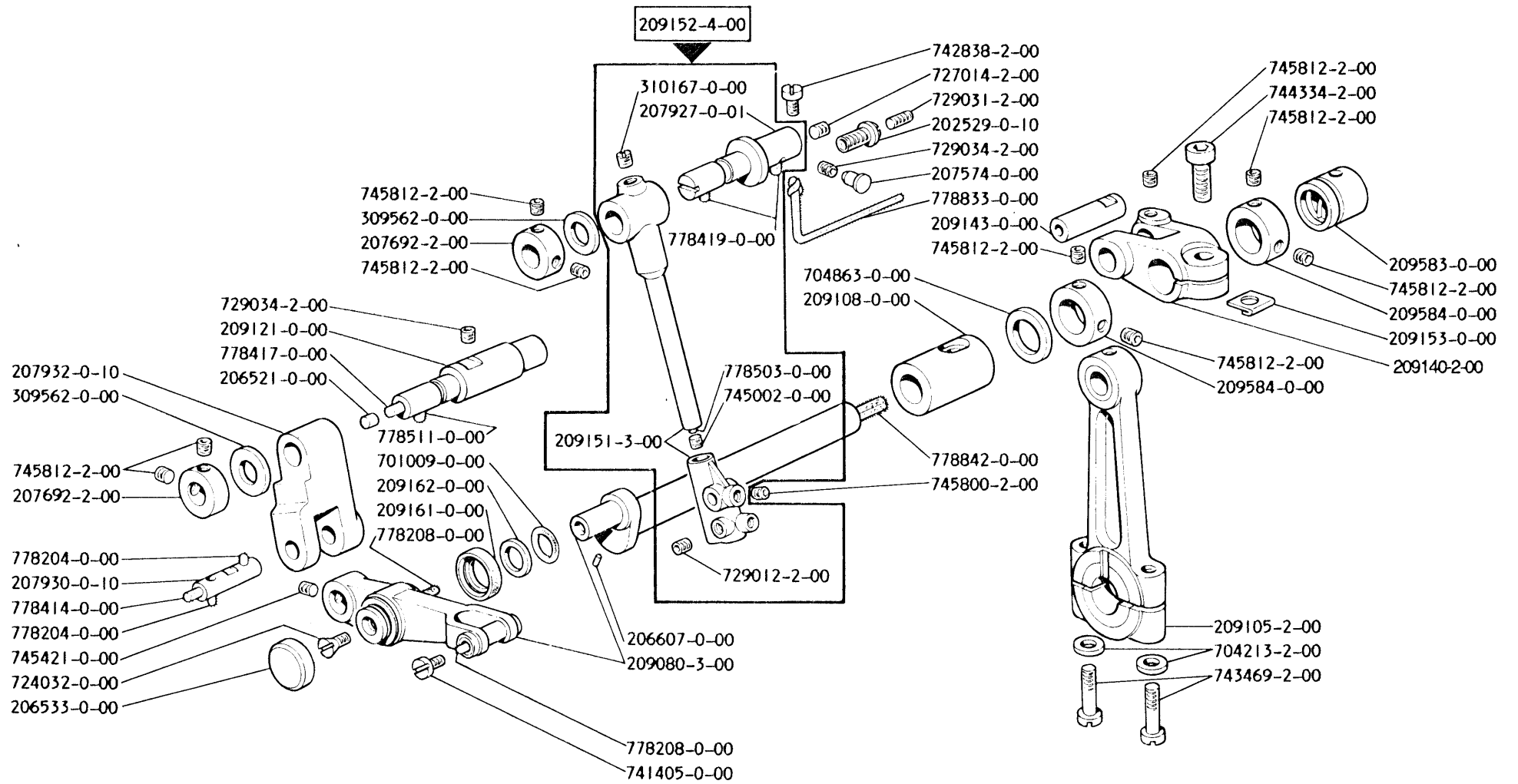

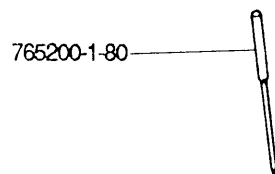
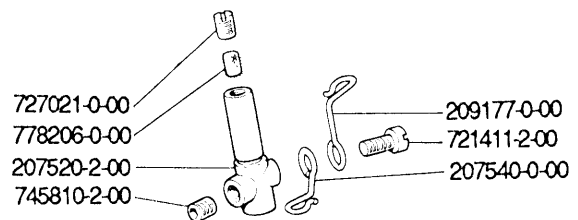
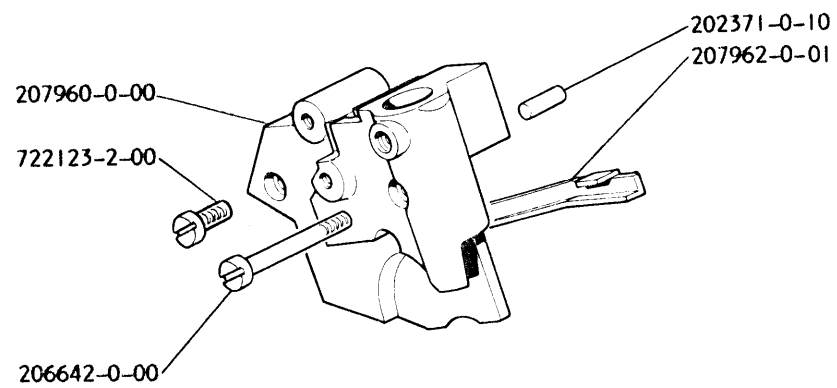

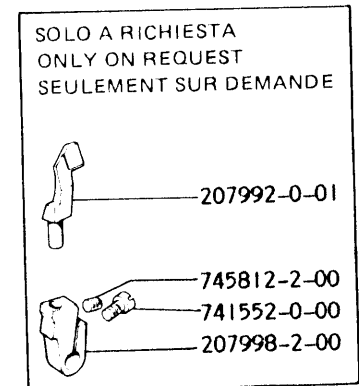
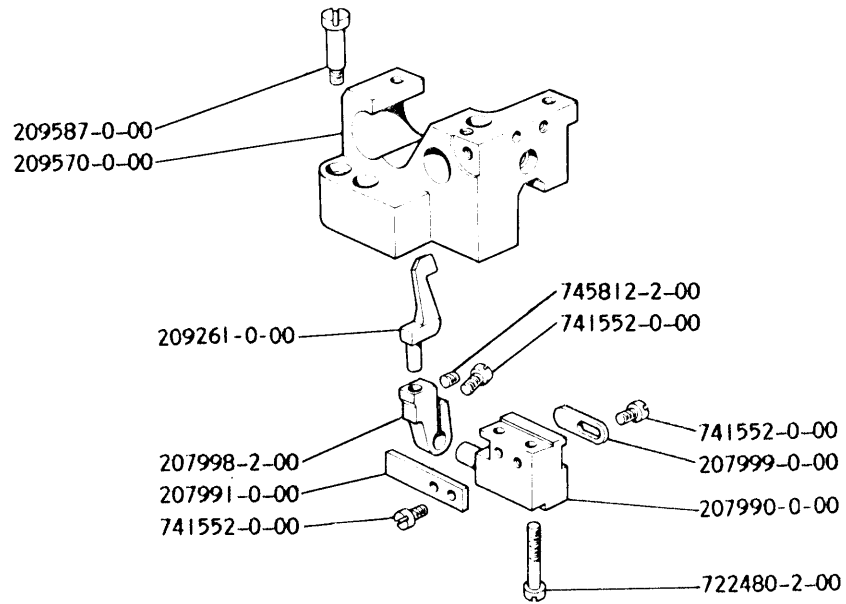
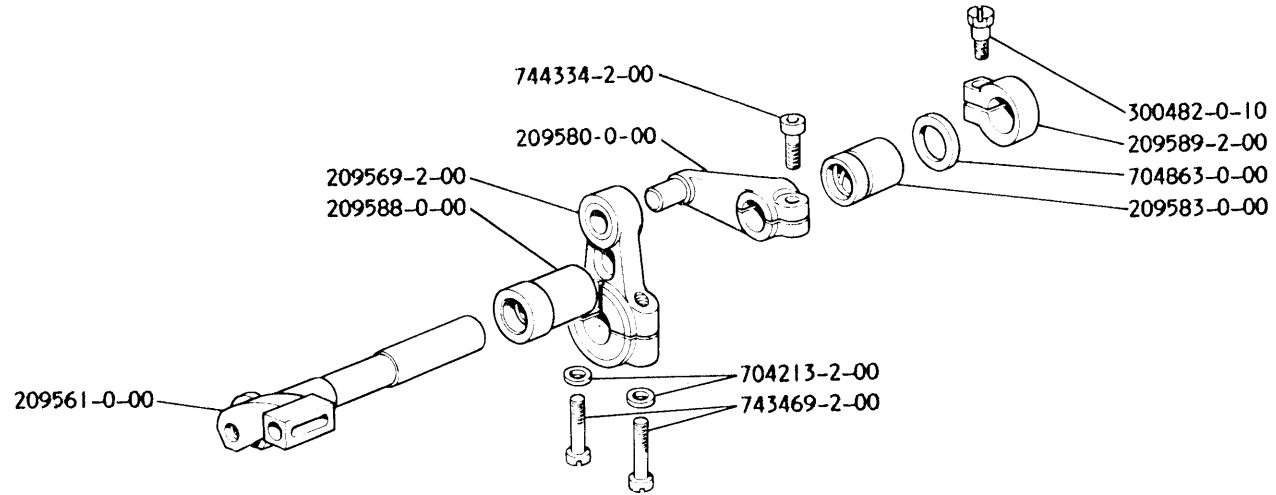

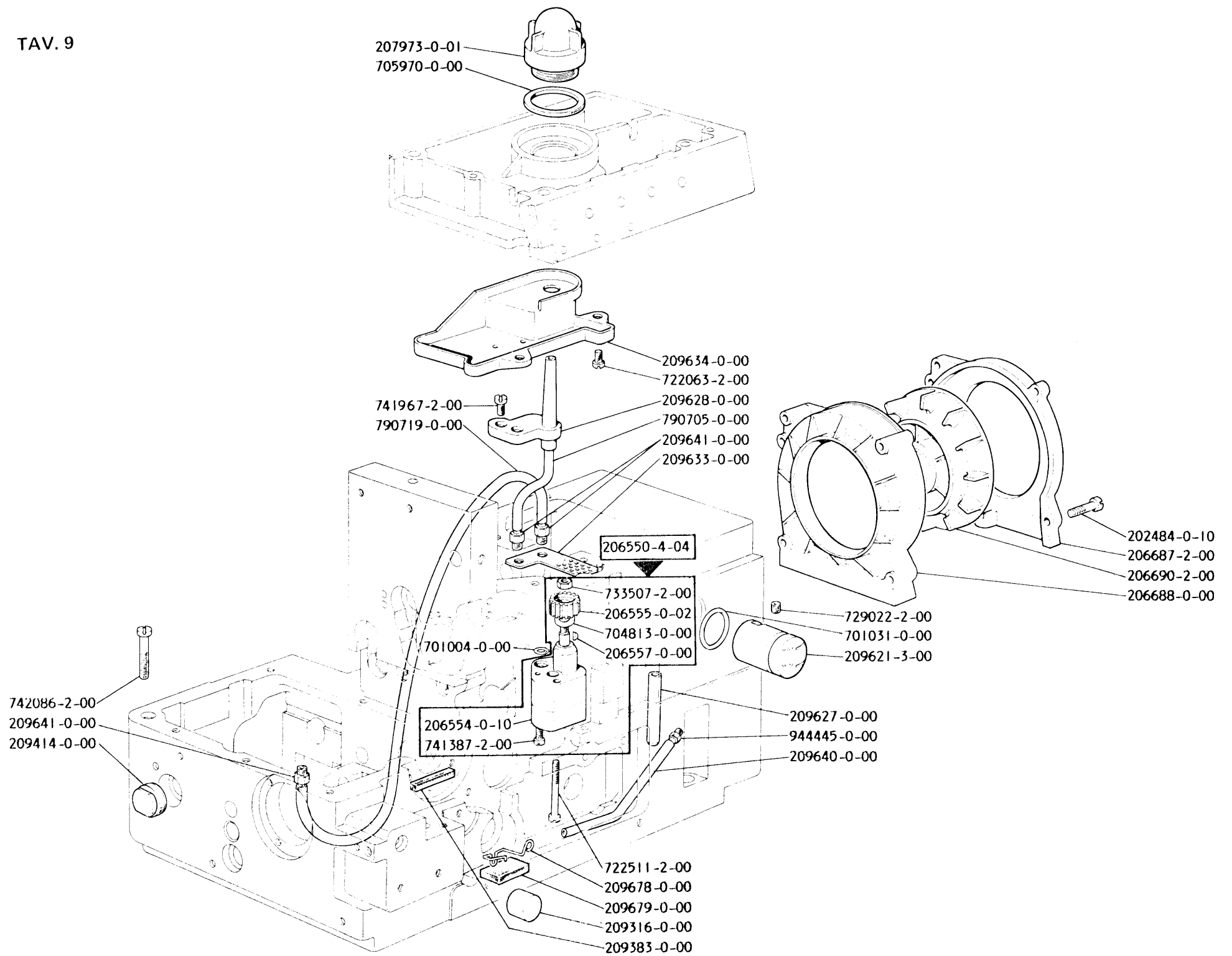

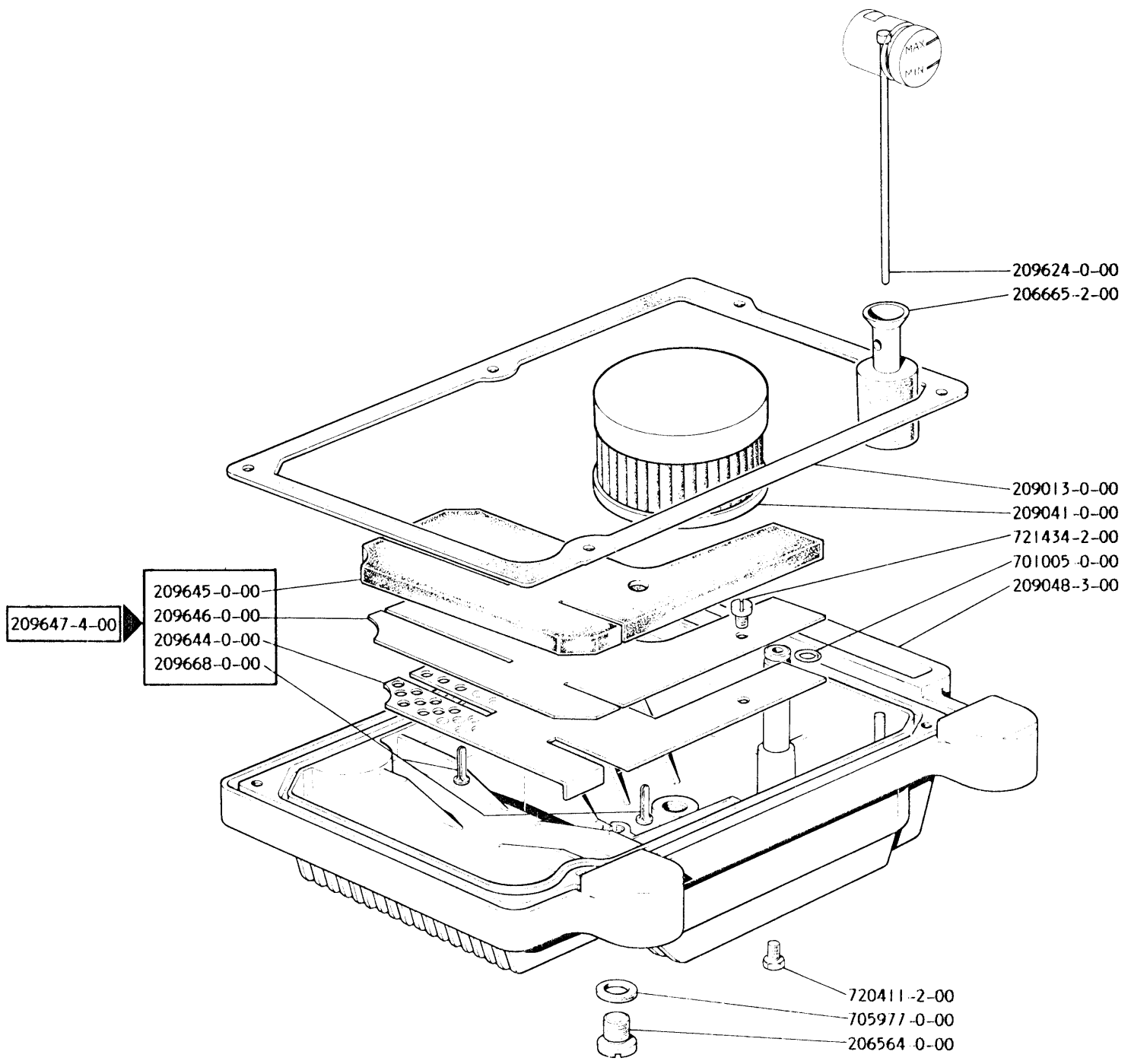

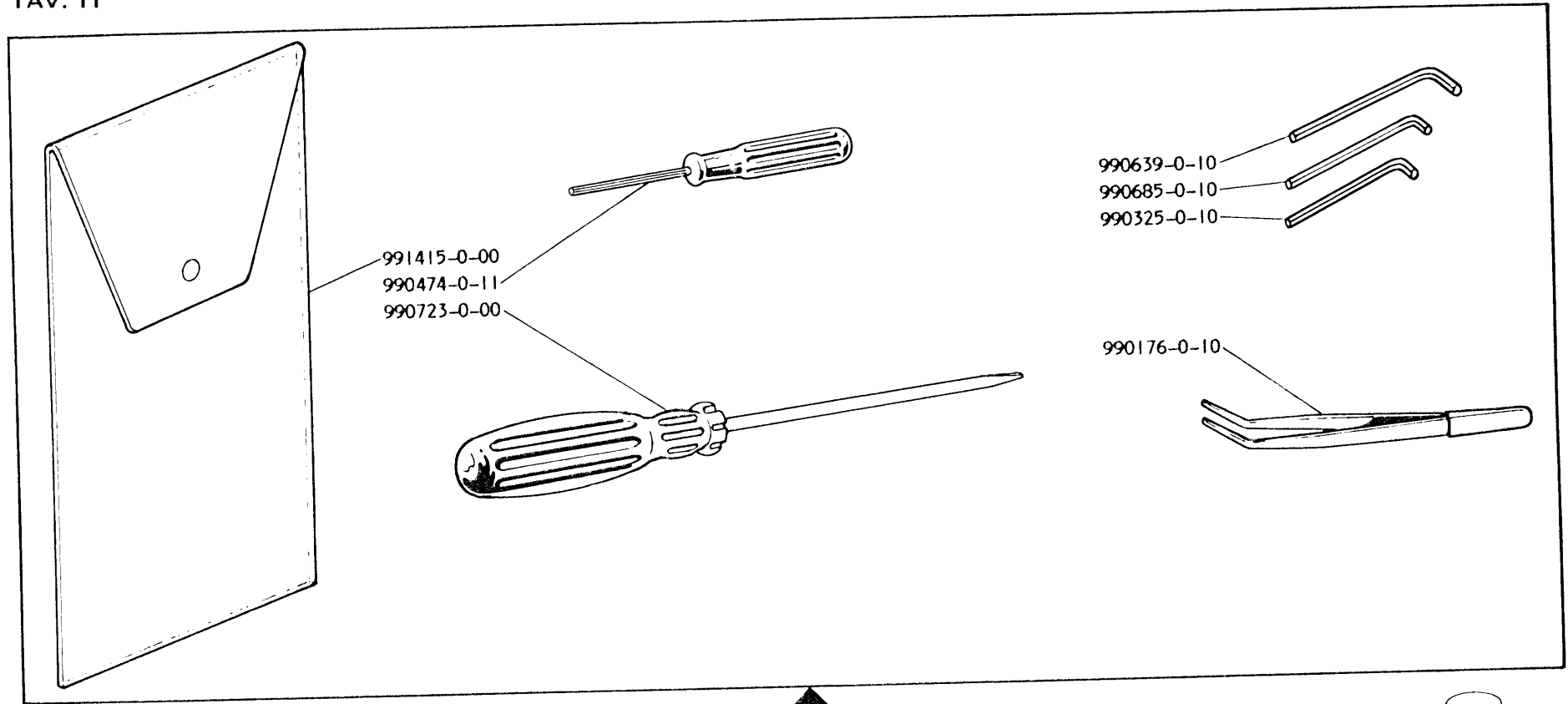

991415-0-00  
 990474-0-11  
 990723-0-00

990639-0-10  
 990685-0-10  
 990325-0-10

990176-0-10

991400-4-03

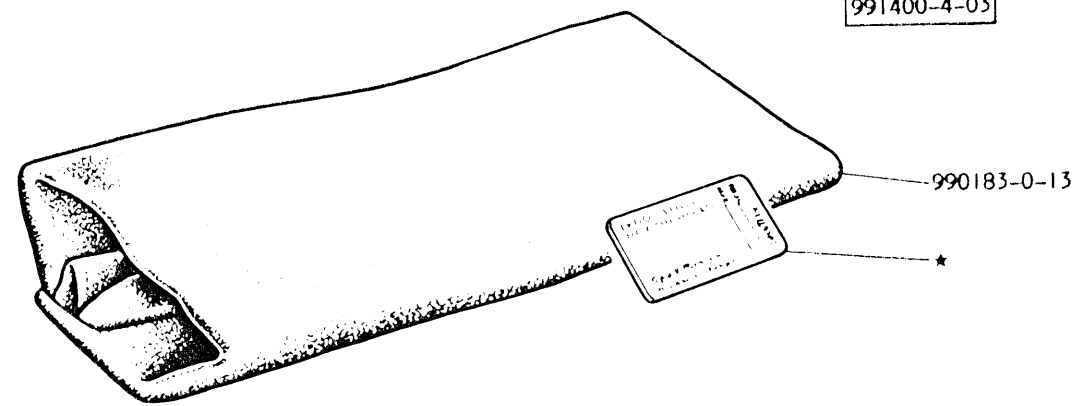

990183-0-13

991280-0-01

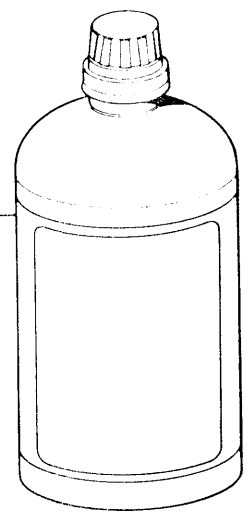

★ per l'ordinazione della bustina  
 citare lo stesso simbolo dell'ago  
 montato sulla testa

to order packet of needles  
 please specify symbol of  
 needle fitted on machine

pour commander un sachet  
 d'aiguille donner le symbol de  
 l'aiguille montée sur la tête

PIAZZAMENTO NORMALE  
NORMAL SETTING  
PLACEMENT NORMAL

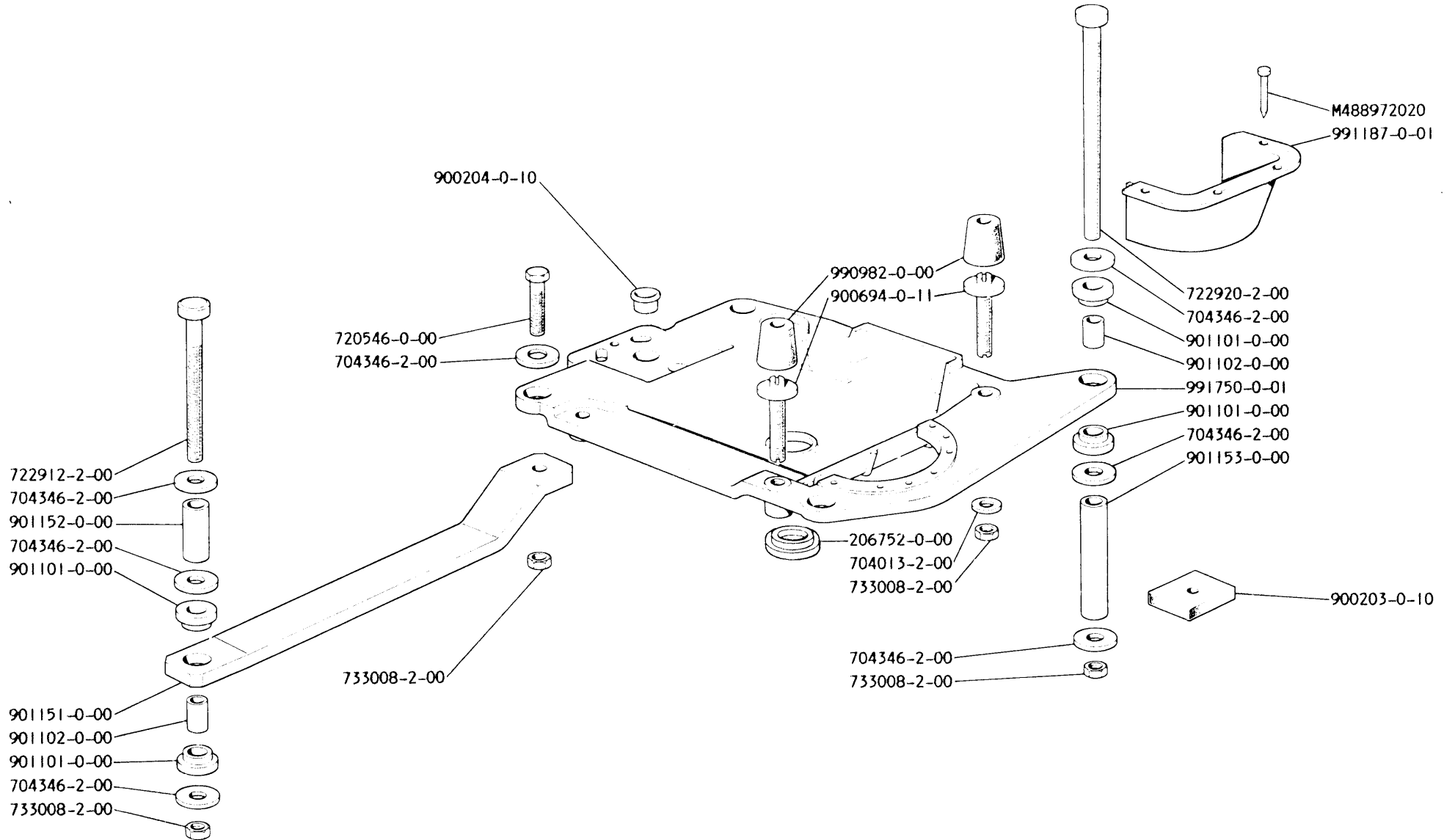

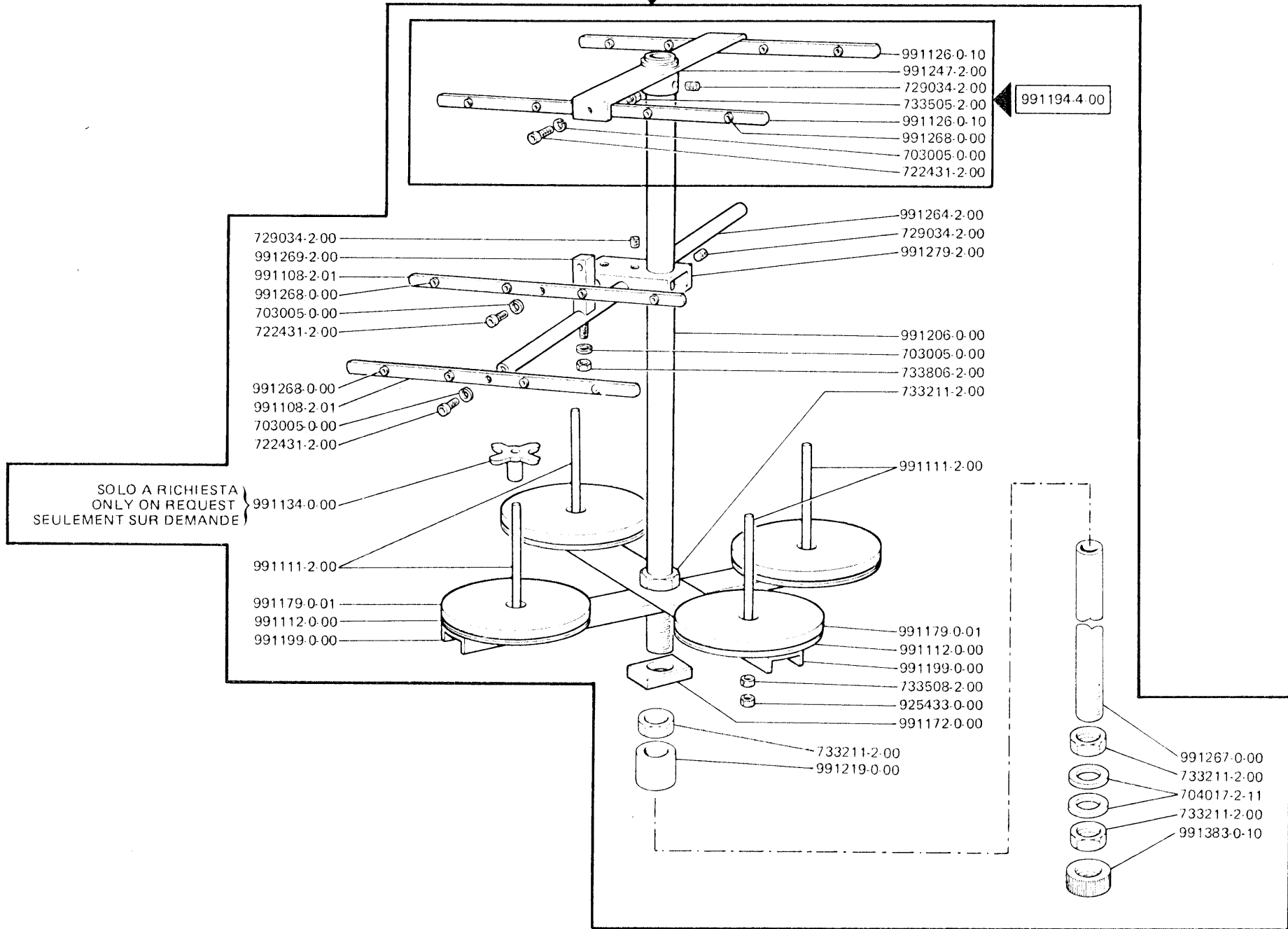

991120-5-02



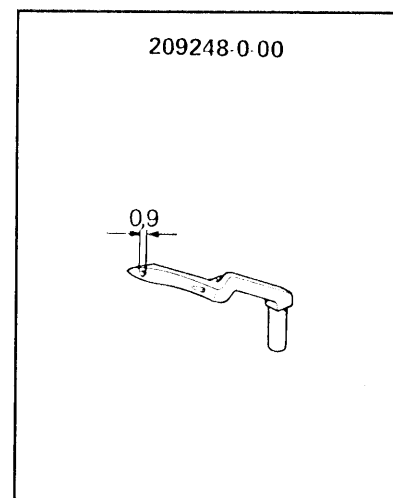
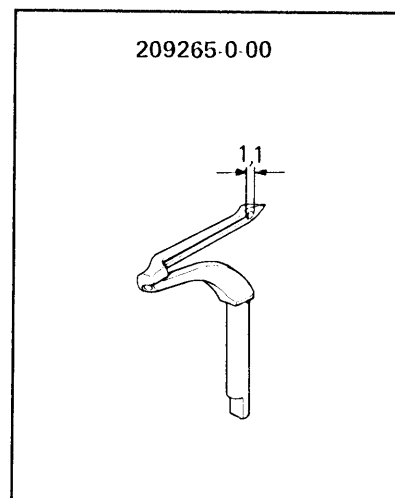
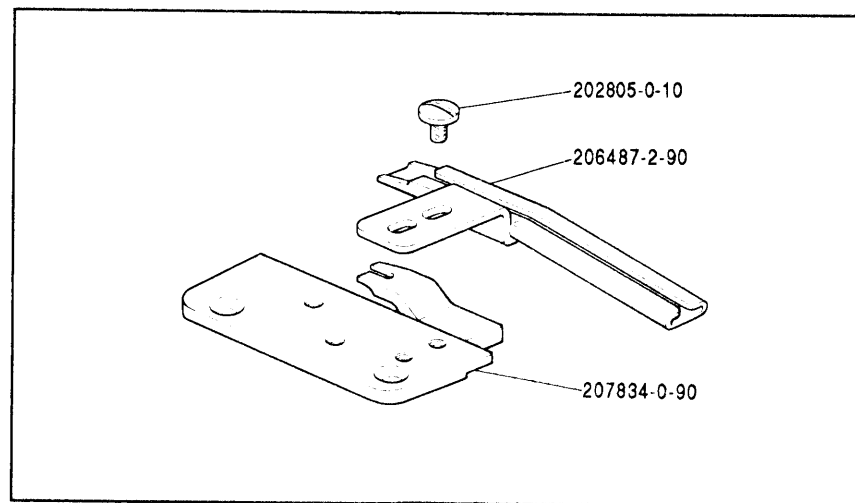

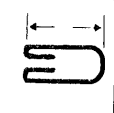

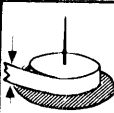
SIMBOLO SYMBOL SYMBOLE				TESTA HEAD TETE
206187-0-00	6	0,8	20	627-41-1CS-01
206188-0-00	4	0,5	16	
206189-0-00	8	0,8	25	
206190-0-00	9	0,8	30	

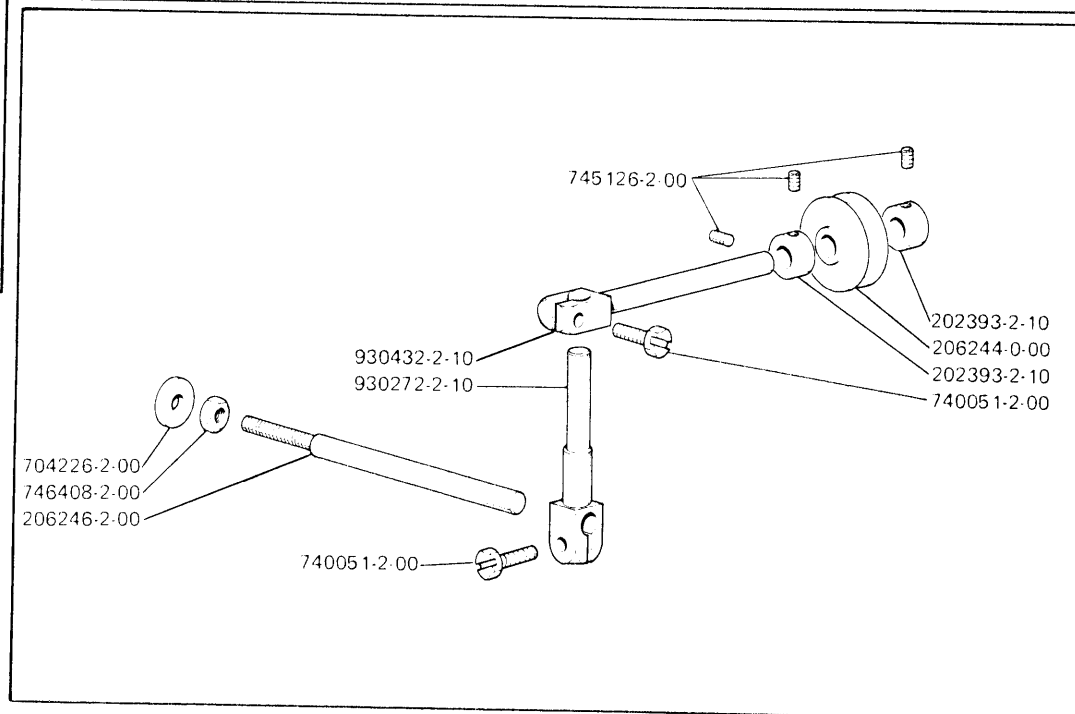
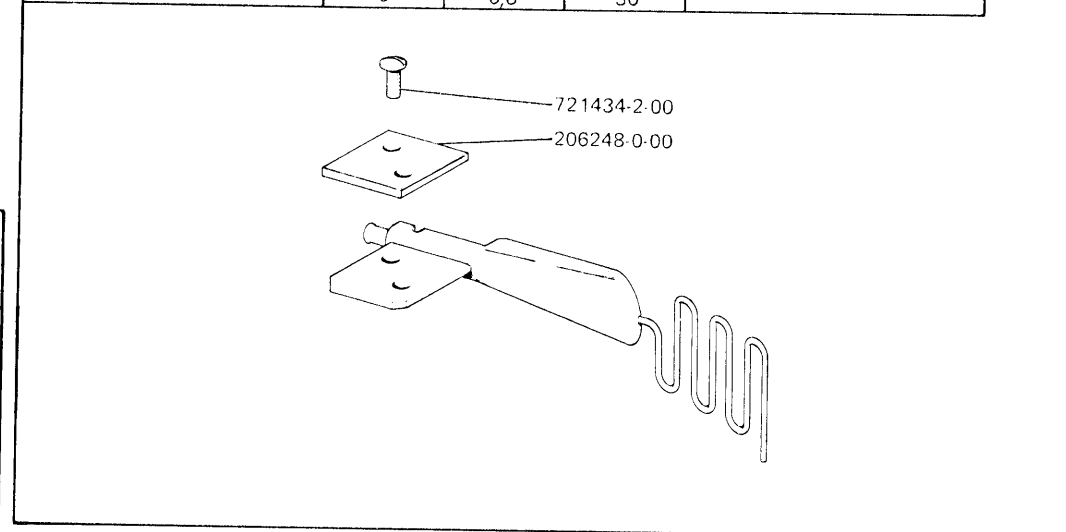
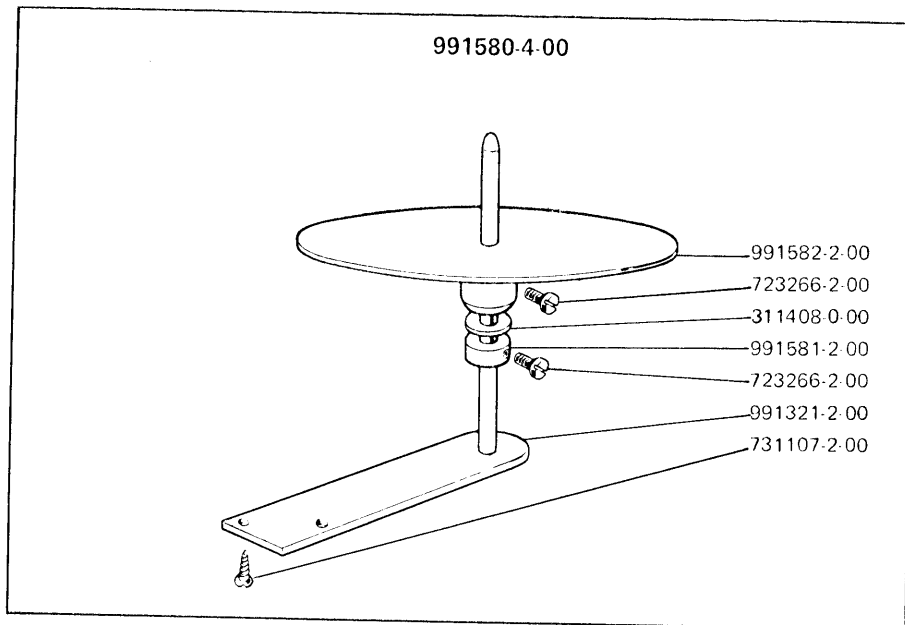

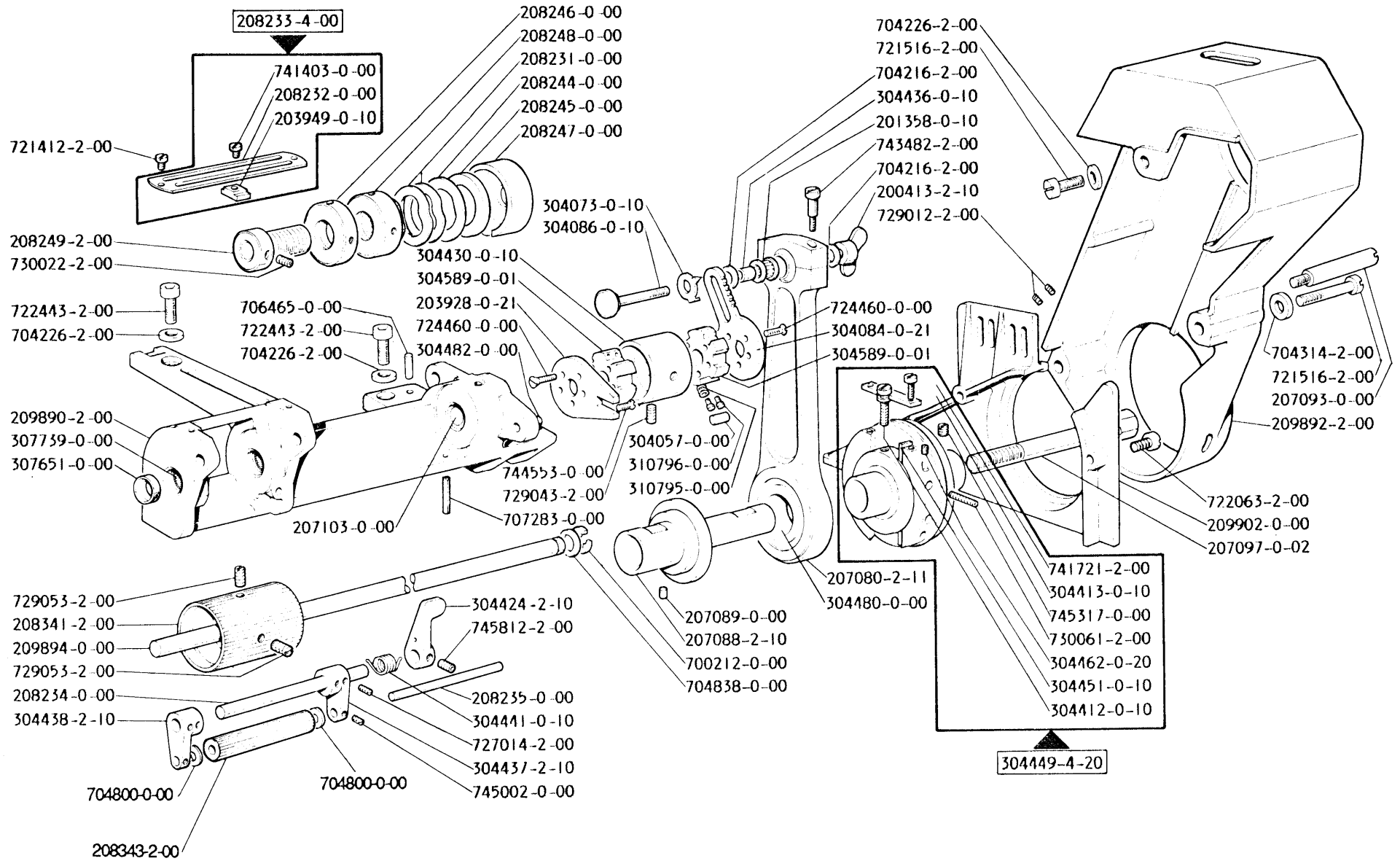

SOLO A RICHIESTA  
ONLY ON REQUEST  
SEULEMENT SUR DEMANDE

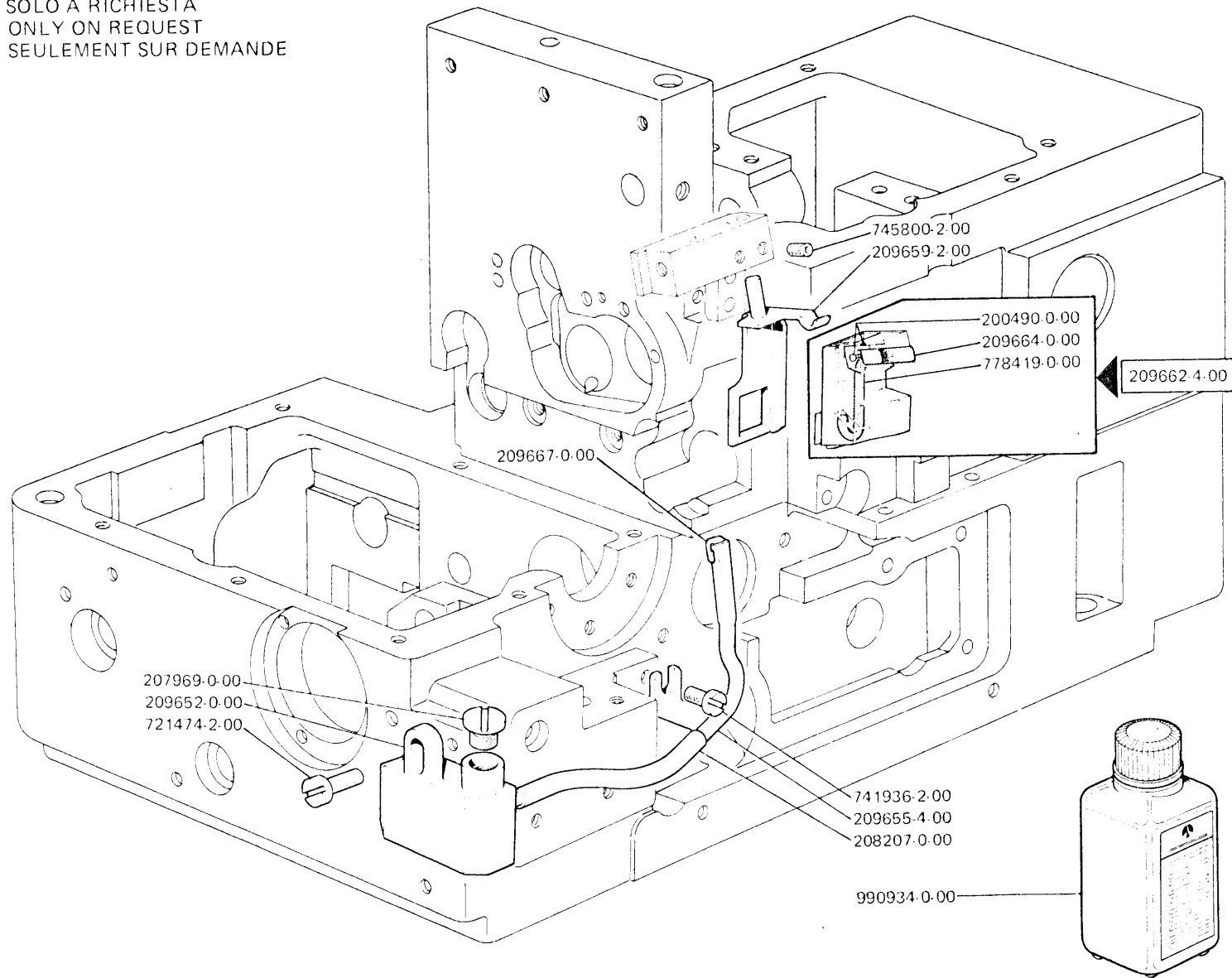

**Rimoldi SpA** - 33, Via Montebello - 20020 Olcella - Milano (Italy)  
Tel. (0331) 563.111 - Telex 332299 - 312243 - Telefax (0331) 563.485 - 563.564 -