

203-90 per teste
for heads
pour têtes

627-00-1CD-01
627-00-1CD-02
627-00-1CD-06
627-00-1CD-07
627-00-1CD-20
627-00-1CD-25
627-00-1CD-30
627-00-1CD-31
627-00-1MD-23
627-00-1SD-02
627-00-1SD-07
627-00-1SD-31

203-98 per teste
for heads
pour tête

627-00-1CD-01
627-00-1CD-02
627-00-1CD-07
627-00-1CD-30
627-00-1CD-31
627-00-1SD-02
627-00-1SD-07
627-00-1SD-31
627-10-1CD-06
627-10-1SD-06

208-93 per teste
for heads
pour têtes

627-00-2CD-15
627-00-2CD-16
627-00-2CD-17
627-00-2CD-18
627-00-2CD-31
627-00-2CD-32
627-00-2CD-41
627-00-2CD-45
627-00-2MD-02
627-00-2MD-20
627-00-2MD-21
627-00-2MD-36

224-31 per teste
for heads
pour têtes

627-...
629-...
630-...

203-90

203-98

208-93

224-31

ISTRUZIONI PER LA CONSULTAZIONE DEL CATALOGO PER TESTE O PER APPARECCHIATURE

- Tutti i particolari delle teste sono rappresentati in più tavole come indicato nell'indice.
- I particolari sono esplosi nelle stesse posizioni in cui si trovano nelle teste.
- Le linee tratteggiate indicano i collegamenti tra i pezzi che per ragioni di disegno o di spazio non possono essere illustrati nello stesso asse.
- I simboli racchiusi da un riquadro (es. xxxxxx-x-xx) si riferiscono sempre a gruppi o sottogruppi.
- Nella rappresentazione grafica i componenti dei gruppi sono racchiusi da un riquadro; i componenti dei sottogruppi sono anch'essi riquadrati all'interno del gruppo.

TAVOLE CON PARTICOLARI COMUNI A TUTTE LE TESTE

- I simboli dei particolari o dei gruppi si leggono direttamente in corrispondenza dei pezzi.

TAVOLE CON PARTICOLARI NON COMUNI A TUTTE LE TESTE

- I simboli dei particolari o dei gruppi si leggono direttamente in corrispondenza dei pezzi.
- I particolari specifici per le singole teste sono indicati nel disegno con un numero progressivo evidenziato da un cerchio per i pezzi singoli o piccoli gruppi e da un quadrato per i gruppi principali. Per ricercare il simbolo del pezzo e del gruppo occorre consultare la relativa tabella riportata nella stessa tavola.

TAVOLE DOPPIE

- Per facilitare la consultazione alcune tavole sono state duplicate e sono indicate con lo stesso numero affiancato da una lettera (es. 3/A - 3/B).

ORGANI DI CUCITURA - GUIDE - ACCESSORI VARI

- Gli organi di cucitura - le guide - gli accessori vari sono preceduti da tavole riepilogative con l'indicazione dei particolari in dotazione e a richiesta.

AGHI

- Gli aghi sono contraddistinti dal sistema e dalla finezza. Il sistema dell'ago e la finezza sono marcati oltre che sulla busta, anche sull'ago stesso. Nelle ordinazioni precisare, oltre al simbolo, il sistema e la finezza degli aghi desiderati. In caso di dubbio allegare un ago campione o una busta vuota.

INSTRUCTIONS TO CONSULT THE CATALOGUE FOR HEADS OR FOR DEVICE

- All the spare parts are illustrated in several tables as indicated in the index.
- The parts are illustrated as they belong together in the machine
- The dashed illustration shows where the adjacent parts belong
- The symbols included in a square (e.g. xxxxxx-x-xx) are always referred to assemblies or sub-assemblies.
- In the graphical representation the components belonging to sub-assemblies are also included in a square within their assembly.

TABLES WITH PARTS COMMON TO ALL HEADS

- The symbols of the parts or of the assemblies can be read in direct reference to the parts.

TABLE WITH PARTS NOT COMMON TO ALL HEADS

- The symbols of the parts or of the assemblies can be read in direct reference to the parts.
- In the drawing the specific parts for the single heads are indicated by a progressive figure which is made evident by a circle for the single parts or small assemblies and by a square for the main assemblies. The symbol of the part or of the assembly can be located by consulting the relevant part-list included in the same table.

DOUBLE TABLES

- For easier reference, some tables have been duplicated. They are indicated by the same figure plus an additional letter, (e.g. 3/A and 3/B)

SEWING PARTS - FOLDERS - VARIOUS ACCESSORIES

- Sewing parts, folders and various accessories are preceded by summary tables indicating standard parts supplied and parts supplied on request.

NEEDLE

- The needles are marked with system and size. The system and size of the needle are shown on the packet as well as on the needle itself. When ordering please state symbol, system and size. If you have doubts, enclose a sample needle or an empty packet with your order.

INSTRUCTIONS POUR LA CONSULTATION DU CATALOGUE POUR TÊTES OU POUR DISPOSITIFS

- Toutes les pièces des têtes sont représentées en plusieurs tables comme nous avons indiqué dans l'index.
- Les pièces figurent sur l'illustration comme elles vont ensemble
- Les figures en tirets montrent le lieu de montage des pièces figurant à côté.
- Les symboles compris entre panneaux (ex. xxxxxx-x-xx) se réfèrent toujours à des groupes ou sous-groupes.
- Dans la représentation graphique les composants des sous-groupes sont eux-mêmes encadrés à l'intérieur du groupe.

TABLES AVEC COMPOSANTS COMMUNS A TOUTES LES TÊTES

- Les symboles des composants et des groupes se lisent directement en correspondance des pièces.

TABLES AVEC COMPOSANTS NON COMMUNS A TOUTES LES TÊTES

- Les symboles des composants et des groupes se lisent directement en correspondance des pièces.
- Les composants spécifiques de chaque tête sont indiqués sur les dessins avec un numéro progressif encerclé pour les simples composants ou petits groupes et numéro encadré pour les groupes principaux. Pour chercher le symbole de la pièce ou du groupe il faut consulter la relative fiche reportée sur la même table.

TABLE DOUBLE

- Pour faciliter la consultation certaines tables ont été doublées et sont indiquées avec le même numéro suivi par une lettre (ex. 3/A - 3/B)

ORGANES DE COUTURES - GUIDES - ACCESSOIRES DIVERS

- Les organes de coutures - les guides - les divers accessoires sont précédés de tables résumés avec l'indication des composants en dotation et sur demande.

AIGUILLES

- Les aiguilles se différencient par le système et la grosseur. Le système de l'aiguille et sa grosseur, sont indiqués non seulement sur le sachet mais également sur l'aiguille. Dans l'ordre précisif, en plus du symbole, le système et la grosseur des aiguilles désirés. En cas de doute, joindre une aiguille comme modèle ou un sachet vide.

INDICE NUMERICO INDEX

Part. N.	Tav.	Part. N.	Tav.	Part. N.	Tav.	Part. N.	Tav.
202184-0-11	4-5	707221-0-00	2	920642-0-00	4-5	920829-0-00	4-6
	6-7	720431-2-00	2	920643-0-00	4-5	920830-0-00	6-7
202192-0-10	4-5	720464-2-00	3	920644-0-00	4		8
202195-0-11	4-5	720464-4-00	3	920645-0-00	4	920831-0-00	6-7
	6	720484-2-00	3	920647-0-00	4-6		8
202201-0-11	4-5	721443-2-00	2	920648-0-00	4	920833-0-01	6-7
	6-7	721484-2-00	2	920649-0-00	4		8
202227-0-10	1/A	729011-2-00	1	920650-0-00	4	920835-3-01	6-7
202229-0-11	1/A	741413-2-00	4-5	920651-0-00	5		8
202556-0-00	1/A		6-7	920652-0-00	5	920848-3-00	4-5
202558-0-00	1/A	741431-2-00	4-5	920653-0-00	5		6
202609-0-10	5		6-7	920654-0-00	5-6	920850-0-00	7
202648-0-11	4	741665-2-00	4-5		7	920854-3-01	6-7
202681-0-10	1/A		6-7	920656-0-00	5	920856-0-00	6-7
203021-0-12	4		8	920657-0-00	6	920860-3-01	5
203025-0-10	4-5	741675-2-00	4-5	920658-0-00	4-5	920861-0-01	5
	6-7		6-7		6	920884-3-01	5
203041-0-10	5	741685-2-00	5-6	920659-0-00	4	920924-0-00	2
203112-0-11	5	741967-2-00	1	920690-0-01	6-7	920925-0-00	2
203483-0-11	4-5	743238-2-00	1	920691-0-00	6-8	920927-0-00	2
	6	745800-2-00	1	920692-0-01	8	920962-3-00	7
203540-0-10	6-7	746204-0-00	3	920693-0-00	6-8	920963-0-00	7
	8	746406-2-00	1	920694-0-00	6	920964-0-00	7
203609-0-10	6	900448-0-00	3	920695-0-00	6-7	925679-0-00	3
203768-0-12	5-6	900637-4-00	3	920696-0-01	7-8	920653-0-00	5
203772-0-11	5-6	900922-4-00	3	920697-0-00	7-8	930601-0-01	1
	7-8	900923-0-00	3	920698-0-00	7-8	990311-0-10	3
203796-3-01	4	900924-0-00	3	920699-0-00	7-8	990856-0-10	3
204938-0-10	2	900926-0-00	3	920700-0-00	7-8	990857-0-00	3
205952-0-00	4-5	900932-0-00	3	920701-0-00	7-8	991349-0-00	3
	6	902609-0-10	4	920702-0-00	7		
206341-4-00	1/A	910830-0-00	8	920703-0-00	7		
206747-0-01	1/A	920493-2-00	2	920710-4-00	1/A		
206754-0-00	1/A	920497-0-00	1/A	920716-0-00	1/A		
206967-0-00	6	920498-0-00	1/A	920717-0-00	1/A		
207893-0-00	1	920499-0-00	1	920718-0-00	1/A		
207973-0-01	1	920538-4-00	1/A	920719-0-00	1		
208338-0-00	1/A	920539-0-00	1/A	920720-0-00	1		
208339-4-00	1/A	920572-0-02	2	920721-0-00	1		
209017-0-00	1	920577-0-00	1	920728-4-00	1/A		
209753-0-00	1	920603-4-00	1/A	920746-0-00	1		
209755-0-00	1/A	920604-4-00	1/A	920751-3-12	4-5		
209760-0-00	1	920605-4-00	1/A	920752-0-11	4-5		
300218-0-10	1/A	920606-4-00	1/A		7		
304924-0-10	2	920613-0-00	2	920789-3-11	4		
308507-0-00	1/A	920617-0-01	7	920790-0-11	4		
700205-0-00	3	920629-0-00	2	920795-3-11	5-7		
703008-0-00	3	920632-4-01	2	920801-0-11	4-5		
704009-4-00	3	920633-2-00	2	920802-0-10	4-5		
704419-0-00	3	920635-0-00	2	920813-0-00	6		
704813-0-00	1	920640-0-00	4-5	920814-3-01	6		
705970-0-00	1	920641-0-00	4-5	920820-0-00	5		

SOMMARIO SUMMARY SOMMAIRE

TAV. N. TAB. N.	DESCRIZIONE	DESCRIPTION	DESCRIPTION
1-1/A	COPERCHIO E TENSIONI	COVER AND TENSIONS	COUVERCLE ET TENSIONS
2	PIANO DI LAVORO E AFFRANCA CATENELLA	WORKING PLATE AND BACKLATCH	PLAN DE TRAVAIL ET FERMETURE CHAINETTE
3	LEVA ALZAPIEDINO E TIRANTE MOTORE	PRESSER LEVER AND MOTOR TIE ROD	LEVIER SOULEVE PIED PRESSEUR ET TIRANT MOTEUR
4-8	ORGANI DI CUCITURA	SEWING PARTS	ORGANES DE COUTURE

ORGANI DI CUCITURA - SEWING PARTS - ORGANES DE COUTURE

I particolari raffigurati e non richiamati in tabella, si intendono appartenenti alla testa e pertanto vanno ricercati sul catalogo della testa interessata.

In the tables where parts illustrated are not listed, said parts belong to the machine and therefore must be sought in the parts catalogue for the machine in question.

Dans le tableaux ou les pièces illustrées ne sont pas citées, il s'agit de pièces appartenant à la tête; pour ces pièces, il faut consulter le catalogue de la tête en question.

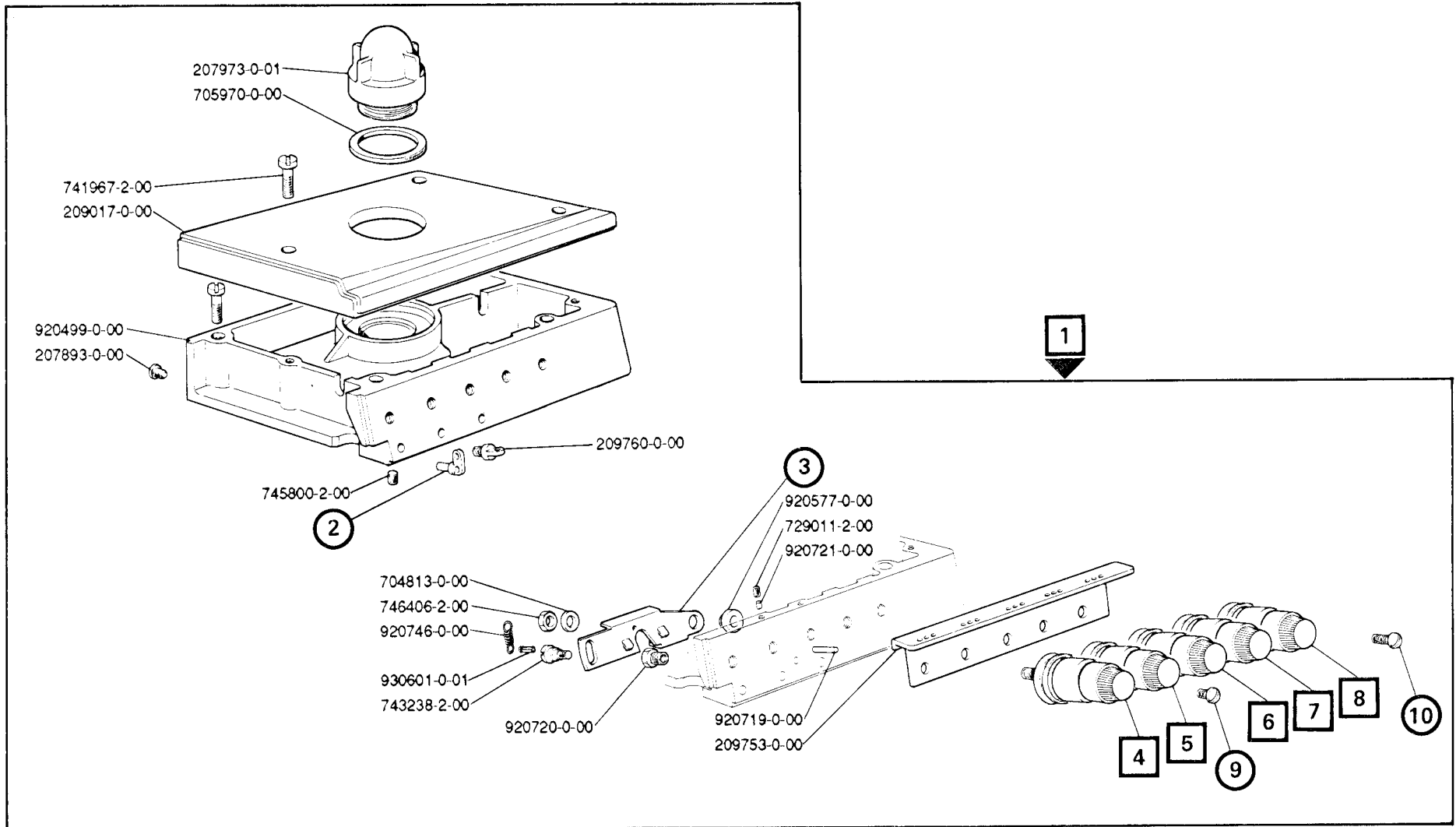

	1	2	3	4	5	6	7	8	9	10
203-98	920604-4-00	---	920498-0-00	---	920710-4-00	920710-4-00	206341-4-00	---	920718-0-00	920539-0-00
203-98 (E-O)	920606-4-00	---	920498-0-00	---	920728-4-00	920728-4-00	920728-4-00	920538-4-00	920718-0-00	---
208-93	920603-4-00	209755-0-00	920497-0-00	---	920710-4-00	920710-4-00	920728-4-00	920538-4-00	920718-0-00	---
208-93 (E-O)	920605-4-00	---	920497-0-00	208339-4-00	920710-4-00	920710-4-00	920728-4-00	920538-4-00	---	---

EO = Per infilatura tipo Estremo Oriente
 EO = For threading type Extreme Orient
 EO = Pour enfilage type Extreme Orient

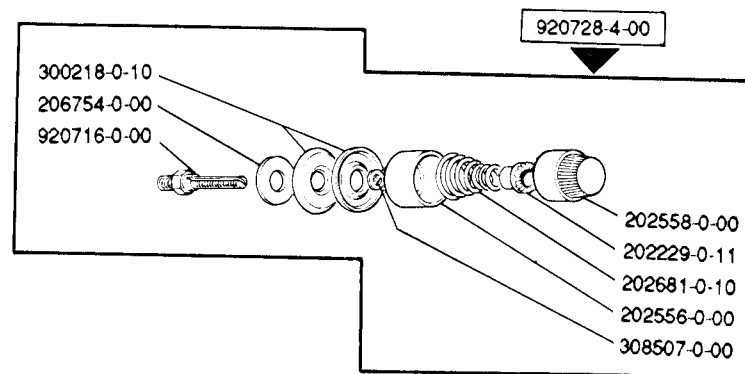
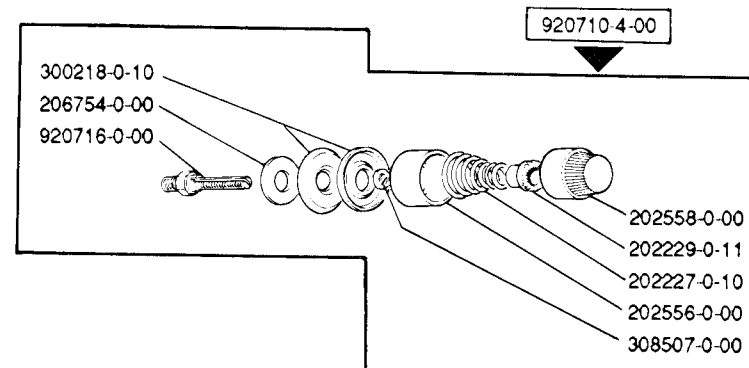
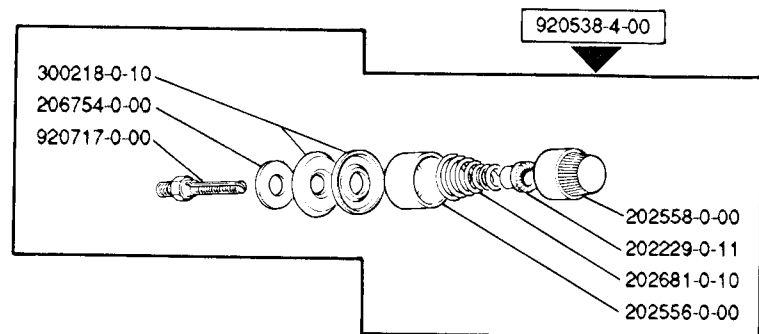
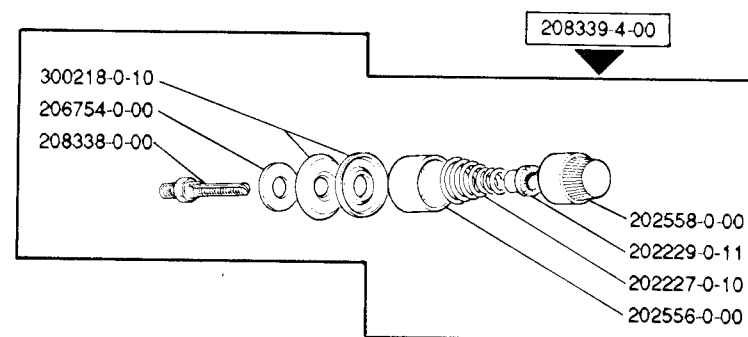
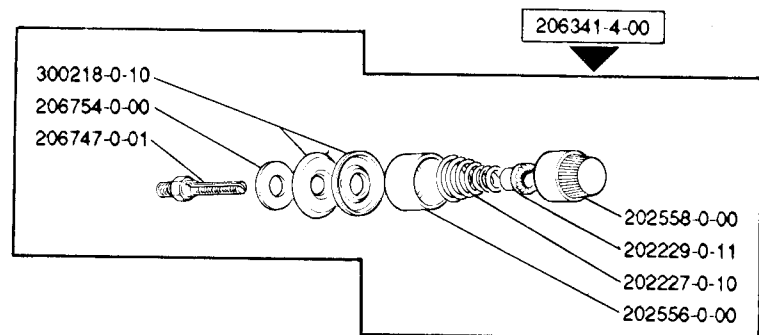

	①	②	③	④
203-90	---	---	920493-2-00	721484-2-00
203-98	720431-2-00	920613-0-00	---	---
203-98 (E-O)	720431-2-00	920629-0-00	---	---
208-93	720431-2-00	920613-0-00	920493-2-00	721484-2-00
208-93 (E-O)	720431-2-00	920629-0-00	920493-2-00	721484-2-00

EO = Per infilatura tipo Estremo Oriente
 EO = For threading type Extreme Orient
 EO = Pour enfilage type Extreme Orient

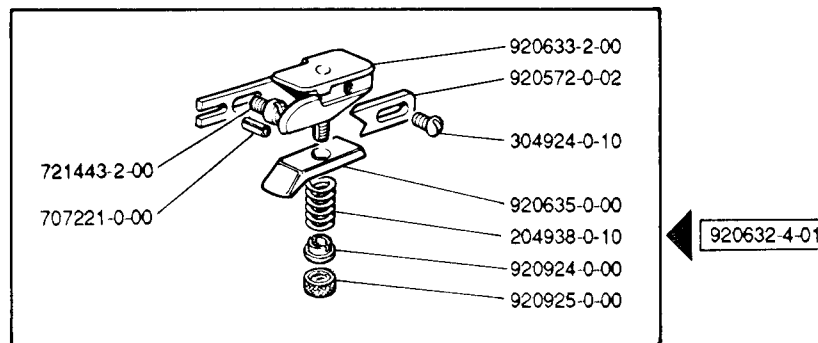
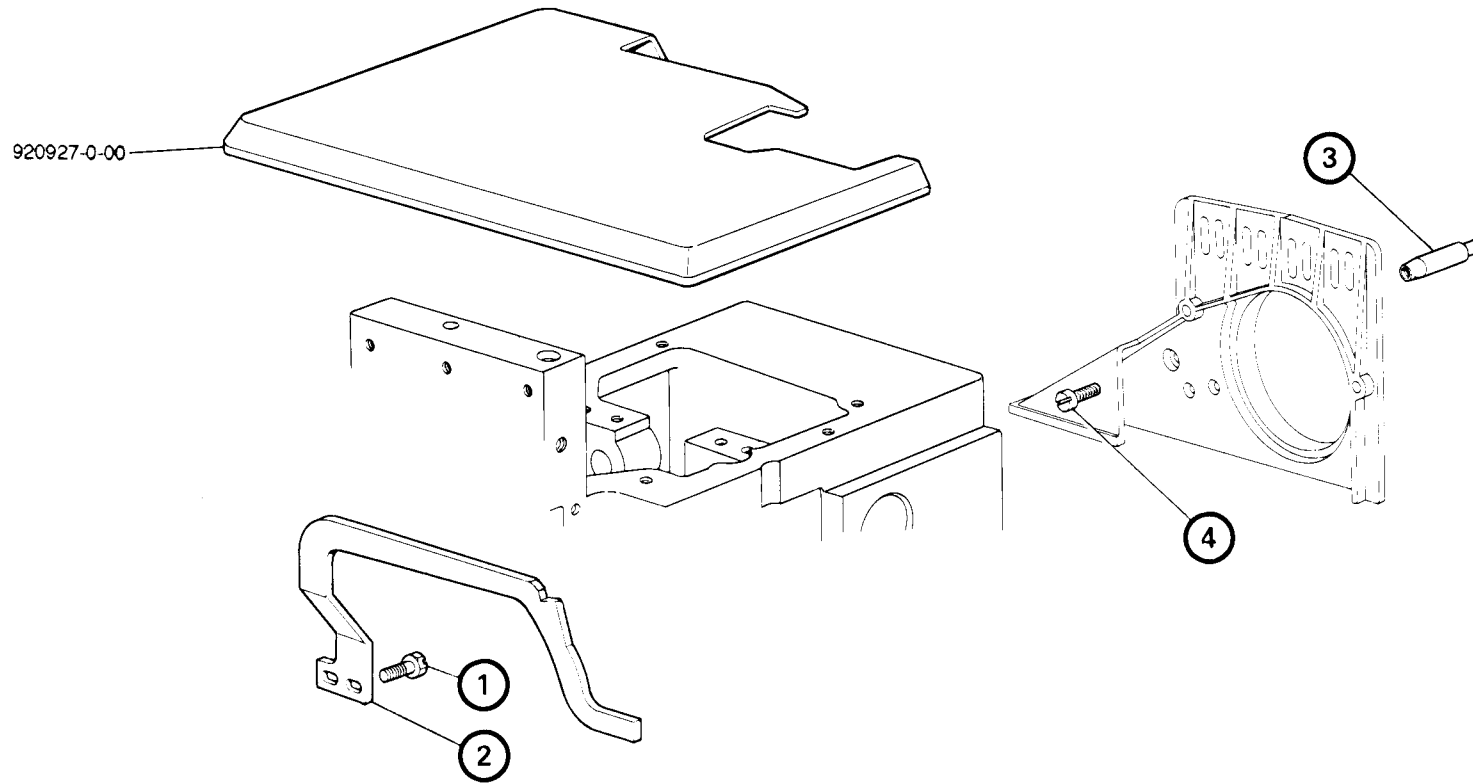

203-98

224-31

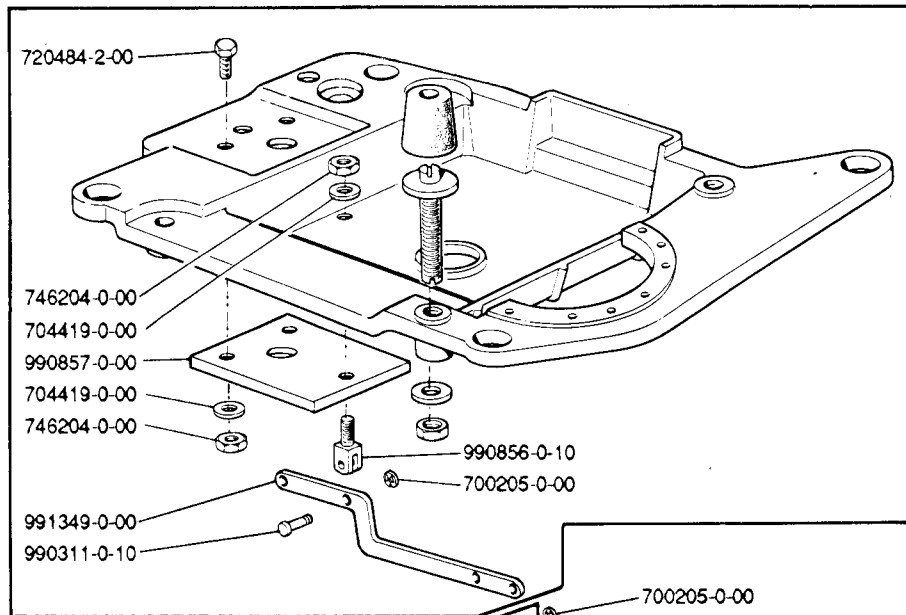

900637-4-00

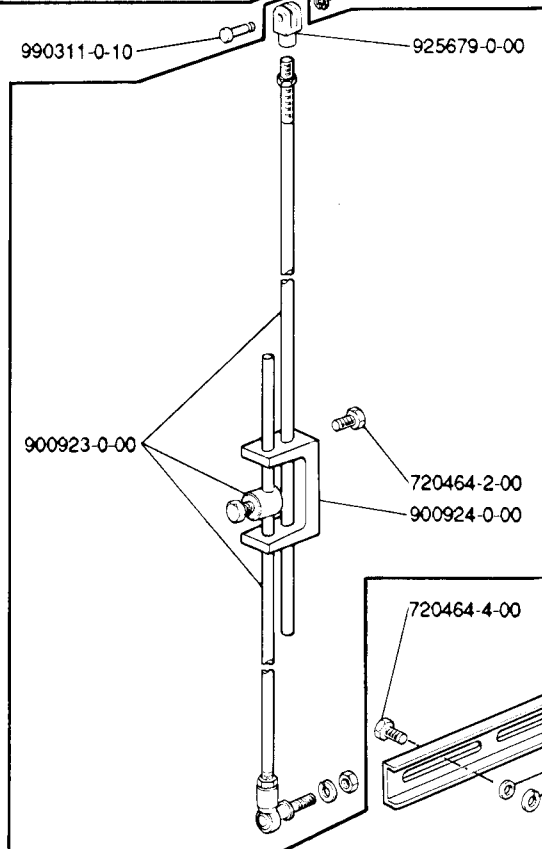

900922-4-00

900932-0-00

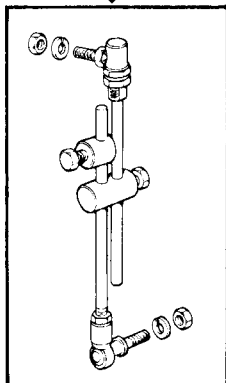

ORGANI DI CUCITURA	SEWING PARTS	ORGANES DE COUTURE
R = A RICHIESTA G = GRIFFE GOMMATE ● ▲ ★ = ABBINAMENTI OBBLIGATORI	R = ON REQUEST G = RUBBERED FEED DOGS ● ▲ ★ = FIXED COUPLINGS	R = SUR DEMANDE G = GRIFFES CAOUTCHOUTEES ● ▲ ★ = JUMELAGES OBLIGES
627-00-1CD-01/203-90	920640-0-00 920641-0-00 920642-0-00 920643-0-00	3 3,4 3,7 4,1
627-00-1CD-01/203-98	920659-0-00	3
627-00-1CD-02/203-90 627-00-1SD-02/203-90	920644-0-00 920645-0-00	R 1,8 2,6
627-00-1CD-02/203-98 627-00-1SD-02/203-98	920658-0-00	3,5
627-00-1CD-06/203-90	920647-0-00	4,5
627-00-1CD-07/203-90 627-00-1SD-07/203-90	920649-0-00 920648-0-00 920650-0-00	R 3 2,4 R 4

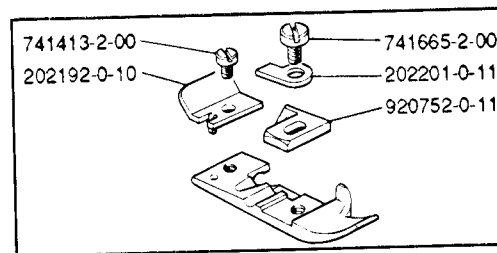

920751-3-12

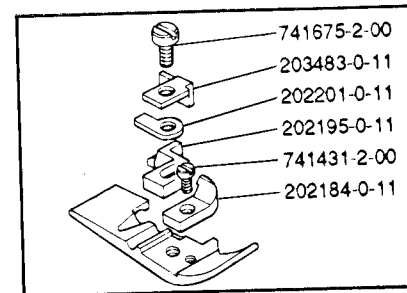

920848-3-00

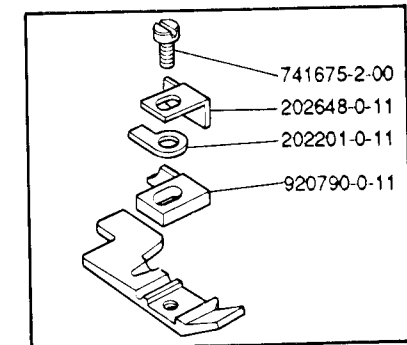

920789-3-11

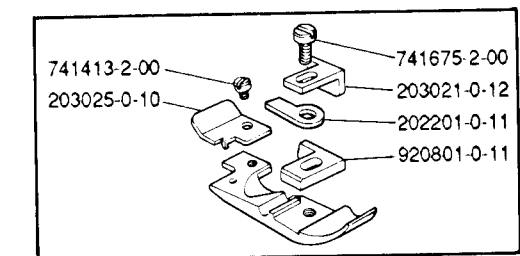

203796-3-01

ORGANI DI CUCITURA	SEWING PARTS		ORGANES DE COUTURE					
R = A RICHIESTA G = GRIFFE GOMMATE ● ▲ ★ = ABBINAMENTI OBBLIGATORI	R=ON REQUEST G=RUBBERED FEED DOGS ● ▲ ★ = FIXED COUPLINGS		R= SUR DEMANDE G= GRIFFES CAOUTCHOUTEES ● ▲ ★ = JUMELAGES OBLIGES					
627-00-1CD-07/203-98 627-00-1SD-07/203-98	920658-0-00	3,5	920829-0-00	1,5	205952-0-00	1,5	202609-0-10	920848-3-00
627-00-1CD-20/203-90	920640-0-00 920641-0-00 920642-0-00 920643-0-00	R 3 R 3,4 R 3,7 R 4,1						920751-3-12
627-00-1CD-25/203-90	920651-0-00	2,5						920860-3-01
627-00-1CD-30/203-90	920652-0-00 920653-0-00 920656-0-00	R 3,3 R 2,3 R 4,5	920802-0-10	1,5				920884-3-01
627-00-1CD-30/203-98	920652-0-00 920653-0-00 920656-0-00	R 3,3 R 2,3 R 4,5						920848-3-00
627-00-1CD-31/203-90 627-00-1SD-31/203-90	920654-0-00	2,8						920795-3-11

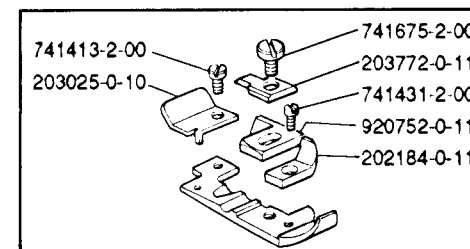
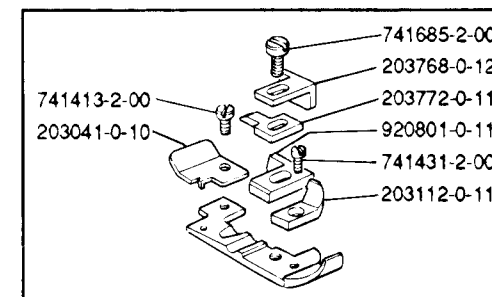
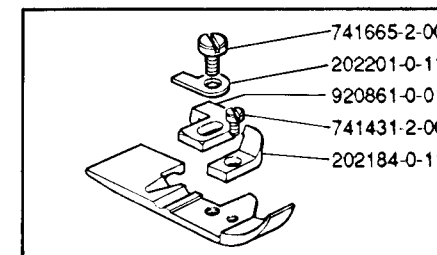
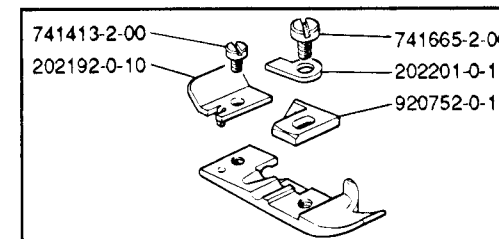
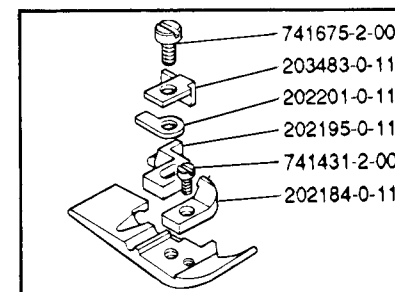

ORGANI DI CUCITURA		SEWING PARTS				ORGANES DE COUTURE			
R = A RICHIESTA G = GRIFFE GOMMATE ● ▲ ★ = ABBINAMENTI OBBLIGATORI		R = ON REQUEST G = RUBBERED FEED DOGS ● ▲ ★ = FIXED COUPLINGS				R = SUR DEMANDE G = GRIFFES CAOUTCHOUTEES ● ▲ ★ = JUMELAGES OBLIGES			
627-00-1CD-31/203-98 627-00-1SD-31/203-98	920654-0-00 920658-0-00	R	2,8 3,5	920829-0-00	1,5	205952-0-00	1,5		920848-3-00
627-00-1MA-23/203-90	920647-0-00		4,5	920813-0-00	2				920814-3-01
627-10-1CD-06/203-98 627-10-1SD-06/203-98	920657-0-00		3,2						
627-00-2CD-15/208-93	920690-0-01 920694-0-00	R	6 7	920830-0-00 920831-0-00	R 1,5 2	203609-0-10	R 2		920835-3-01
627-00-2CD-16/208-93	920695-0-00		6	920856-0-00	1,5				920854-3-01
627-00-2CD-17/208-93	920693-0-00 920691-0-00	R	7 6	920831-0-00 920830-0-00	R 2 1,5	203540-0-00	R 1,5		920835-3-01

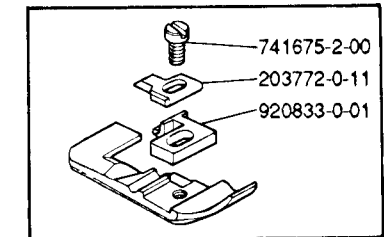
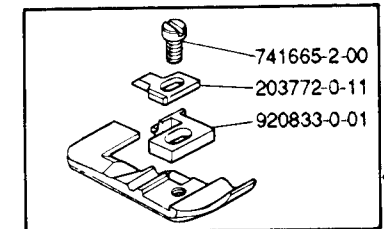
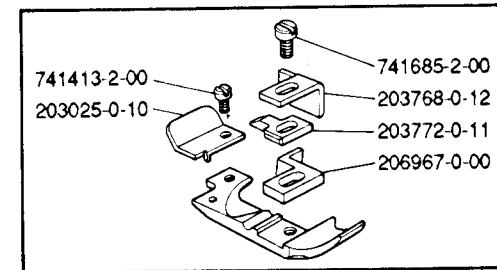
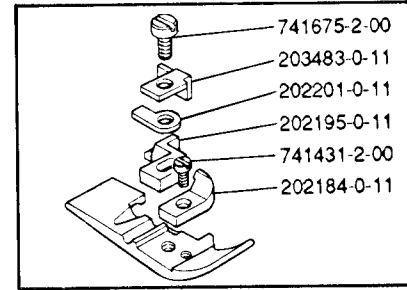

ORGANI DI CUCITURA	SEWING PARTS		ORGANES DE COUTURE						
R = A RICHIESTA G = GRIFFE GOMMATE ● ▲ ★ = ABBINAMENTI OBBLIGATORI	R=ON REQUEST G=RUBBERED FEED DOGS ● ▲ ★ =FIXED COUPLINGS		R=SUR DEMANDE G=GRIFFES CAOUTCHOUTEES ● ▲ ★ =JUMELAGES OBLIGES						
627-00-2CD-18/208-93	920696-0-01 920697-0-00 920698-0-00 920699-0-00 920700-0-00 920701-0-00	R R R R R R	6 5,5 6,5 7 5,5 6,5	920831-0-00 920830-0-00	R	2 1,5	203540-0-10	1,5	920835-3-01
627-00-2CD-31/208-93	920964-0-00● 920654-0-00★		5,5 3,3						920962-3-00● 920795-3-11★
627-00-2CD-32/208-93	920702-0-00 920703-0-00	R	7 6,5	920850-0-00		2			920854-3-01
627-00-2CD-41/208-93	920695-0-00		6	920856-0-00		1,5			920854-3-01
627-00-2CD-45/208-93	920690-0-01		6	920830-0-00		1,5			920835-3-01
627-00-2MD-02/208-93	920617-0-01								

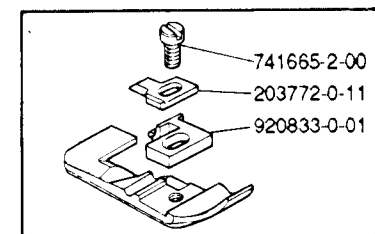

920835-3-01

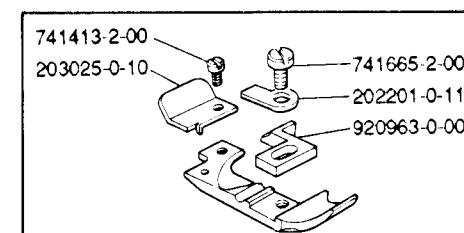

920962-3-00

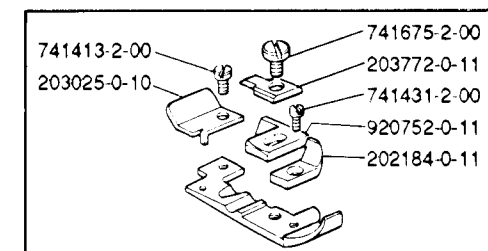

920795-3-11

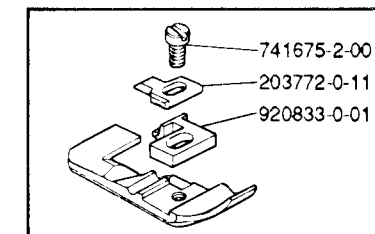

920854-3-01

ORGANI DI CUCITURA		SEWING PARTS				ORGANES DE COUTURE				
R = A RICHIESTA G = GRIFFE GOMMATE ● ▲ ★ = ABBINAMENTI OBBLIGATORI		R = ON REQUEST G = RUBBERED FEED DOGS ● ▲ ★ = FIXED COUPLINGS				R = SUR DEMANDE G = GRIFFES CAOUTCHOUTEES ● ▲ ★ = JUMELAGES OBLIGES				
627-00-2MD-20/208-93	920691-0-00 920692-0-01 920693-0-00	R R	6 5,5 7	920831-0-00 920830-0-00	R	2 1,5	203540-0-10	R	1,5	920835-3-01
627-00-2MD-21/208-93	920691-0-00 920693-0-00	R	6 7	920831-0-00 920830-0-00	R	2 1,5	203540-0-10	R	1,5	920835-3-01
627-00-2MD-36/208-93	920696-0-01 920697-0-00 920698-0-00 920699-0-00 920700-0-00 920701-0-00	R R R R R	6 5,5 6,5 6 5,5 6,5	920831-0-00 920830-0-00	R	2 1,5	203540-0-10	R	1,5	920835-3-01

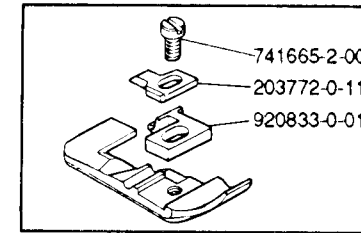

920835-3-01