

538-40

561-40

563-40

**n. 263**

Edizione - Edition 6/82

APPARECCHIATURE ATTACHMENTS DISPOSITIFS VORRICHTUNGEN

**538-40 / 561-40 / 563-40**

PER TESTE	171-11-2MK-04
FOR HEADS	171-10-3MK-01
POUR TETES	171-16-3MK-01
FÜR OBERTEILE	

Il presente Catalogo Pezzi di Ricambio è costituito da due parti: la prima, definita come "Catalogo base", comprende i particolari montati sulla testa più significativa (la prima dell'elenco in copertina); la seconda comprende tutti i particolari delle altre teste basi o derivate, che differiscono da quella del Catalogo base.

Le Teste basi sono elencate in copertina con un carattere più grande rispetto a quello delle derivate.

Nella consultazione del Catalogo tenere presente che:

1. Tutti i particolari non fornibili sciolti non vengono richiamati singolarmente, ma soltanto illustrati nel gruppo d'appartenenza.
2. I riferimenti delle figure dei particolari che compongono il gruppo sono di norma raggruppati in una parentesi. In alcuni casi però, dove non è possibile il raggruppamento, i numeri che nelle tavole illustrative richiamano i singoli pezzi sono affiancati dallo stesso segno particolare, con cui è indicato l'intero gruppo.
3. Sulle tavole relative alle altre teste sono elencati tutti i particolari diversi o non montati sulla testa del Catalogo Base. Dette tavole portano in alto a destra il simbolo della testa cui si riferiscono (con indicato fra parentesi - nel caso di derivata - il simbolo della testa da cui deriva).  
I disegni di questo gruppo di tavole illustrano soltanto i pezzi nuovi o sostanzialmente diversi rispetto a quelli montati sulla testa più significativa del Catalogo.  
I particolari richiamati come simbolo, ma non illustrati, conservano lo stesso numero di figura dei corrispondenti raffigurati sul Catalogo base.  
I particolari comuni a tutte le teste comprese nel Catalogo, vengono richiamati soltanto nel primo gruppo di tavole.  
I particolari definiti come "pezzi annullati" si intendono quelli non montati sulla testa a cui la tavola si riferisce. Nel caso di un gruppo annullato, viene indicato soltanto il simbolo del gruppo, ma devono intendersi annullati anche tutti i particolari componenti il gruppo stesso.  
Per ogni testa viene sempre riportata interamente la tavola relativa agli organi di cucitura.

Per facilitare la ricerca viene riportato l'indice numerico di tutti i particolari illustrati sul Catalogo base, con la relativa tavola in cui gli stessi sono richiamati.

#### AGHI

Gli aghi sono contraddistinti dal sistema e dalla finezza, la quale indica il diametro medio espresso in centesimi di millimetro.

Il sistema dell'ago e la finezza sono marcati oltre che sulla busta, anche sull'ago stesso.

Nelle ordinazioni precisare, oltre il simbolo, il sistema e la finezza degli aghi desiderati. In caso di dubbio, allegare, un ago campione o una bustina vuota.

#### A V V E R T E N Z A

Nella richiesta di parti di ricambio citare sempre il relativo numero di matricola della macchina, il simbolo del particolare e la denominazione ufficiale usata sul catalogo.

This spare parts catalogue is made up of two parts: in the first one, called "basic catalogue", all the details of most representative head are listed (the first head listed on the cover); the second one includes the details of the other main heads or derived ones, which are different from that of the basic catalogue.

The main heads are listed on the cover in bigger lettering to distinguish them from the derived heads

When you consult the catalogue will you please note that:

1. all parts which cannot be supplied by themselves are not indicated alone, but shown together with the group to which they belong;
2. the references of the pictures of the parts making up the group are usually put in brackets  
In some cases, however, when their grouping is not possible, the numbers of the various parts in the tables are marked with the same particular sign with which the whole group is indicated
3. In the tables of the other heads there are listed all the parts not fitted on the head in the basic catalogue  
These tables are marked at the top right hand corner with the symbol of the head which the table refers to  
The drawings in this group of tables show only the parts which are new or basically different from those fitted on the most representative head in the catalogue.  
The parts which are represented only by the symbol but not illustrated keep the same figure number as the corresponding parts shown in the basic catalogue.  
The parts which are common to all the heads in the catalogue are listed only in the first group of tables  
Parts marked "annulled part" are those not fitted on the head which the table refers to.  
When an assembly has been annulled only the assembly symbol is specified, but all the parts forming the assembly must also be considered annulled.  
For each head the table for sewing parts is always repeated completely.

To make it easier to locate the parts, the reference numbers of all of those shown in the basic catalogue are listed together with the number of the table in which they are to be found.

#### NEEDLES

The needles are marked with system and size; the size indicates the average diameter in hundredths of a millimeter.

The system and size of the needle are shown on the packet as well as on the needle itself.

When ordering please state symbol, system and size. If you have doubts, enclose a sample needle or an empty packet with your order.

#### ATTENTION

When ordering spare parts always state the serial number of the machine, the symbol of the part in question and the description given in the catalogue.

Ce catalogue "pièces détachées" est formé de deux parties: la première appelée "catalogue base" comprend toutes les pièces montées sur la tête la plus significative (celle en tête de la liste de couverture), la seconde comprend toutes les pièces montées sur les autres têtes de base ou dérivées qui sont différentes de celle du "catalogue base".

Les têtes de base sont énumérées sur la couverture, en caractères plus grands que les têtes dérivées.

Lorsque l'on consulte le catalogue, se souvenir que:

1. Toutes les pièces qui ne sont pas fournies séparément mais qui font partie d'un groupe, ne sont pas indiquées séparément.
2. Les symboles des pièces qui forment un groupe sont regroupés entre parenthèses. Cependant, lorsque ceci n'a pas été possible, les symboles, qui dans les tables d'illustration correspondent aux pièces, sont suivis du même signe particulier qui indique le groupe tout entier.
3. Dans les tables relatives aux autres têtes, nous avons indiqué toutes les pièces différentes de celles de tête du "catalogue base" ou qui ne sont pas montées sur ces dernières. Ces tables portent, en haut à droite, le symbole des têtes auxquelles elles se réfèrent (pour les dérivées, le symbole de la tête de laquelle elles dérivent est indiqué entre parenthèses).  
Les dessins de ce groupe de tables représentent seulement les nouvelles pièces ou celles qui sont différentes des pièces montées sur la tête la plus significative du catalogue.  
Les pièces indiquées par un symbole, mais qui ne sont pas illustrées, gardent le même numéro de dessin que celles correspondantes, illustrées sur le catalogue base.  
Les pièces communes à toutes les têtes du catalogue, sont indiquées seulement dans le premier groupe de tables.  
Les pièces définies comme "pièces annulées" sont celles qui ne sont pas montées sur la tête à laquelle se réfère la table. Dans le cas de l'annulation d'un groupe, nous indiquons seulement le symbole du groupe, mais toutes les pièces qui forment ce groupe sont annulées.  
Pour chaque tête est toujours indiquée la table se référant aux organes de couture.

Pour faciliter la recherche, le catalogue renferme l'index numérique de toutes les pièces illustrées avec indication de la table dans laquelle elles sont indiquées.

#### AIGUILLES

Les aiguilles se différencient par le système et la grosseur, laquelle indique le diamètre moyen exprimé en centièmes de millimètre.

Le système de l'aiguille et sa grosseur, sont indiqués non seulement sur le sachet mais également sur l'aiguille.

Dans la commande, préciser, en plus du symbole, le système et la grosseur des aiguilles désirées. En cas de doute, joindre une aiguille comme modèle ou un sachet vide.

#### ATTENTION

Dans la commande de pièces détachées, indiquer toujours le numéro de la machine, le symbole de la pièce et la dénomination officielle mentionnée sur le catalogue.



**538-40 / 561-40 / 563-40**

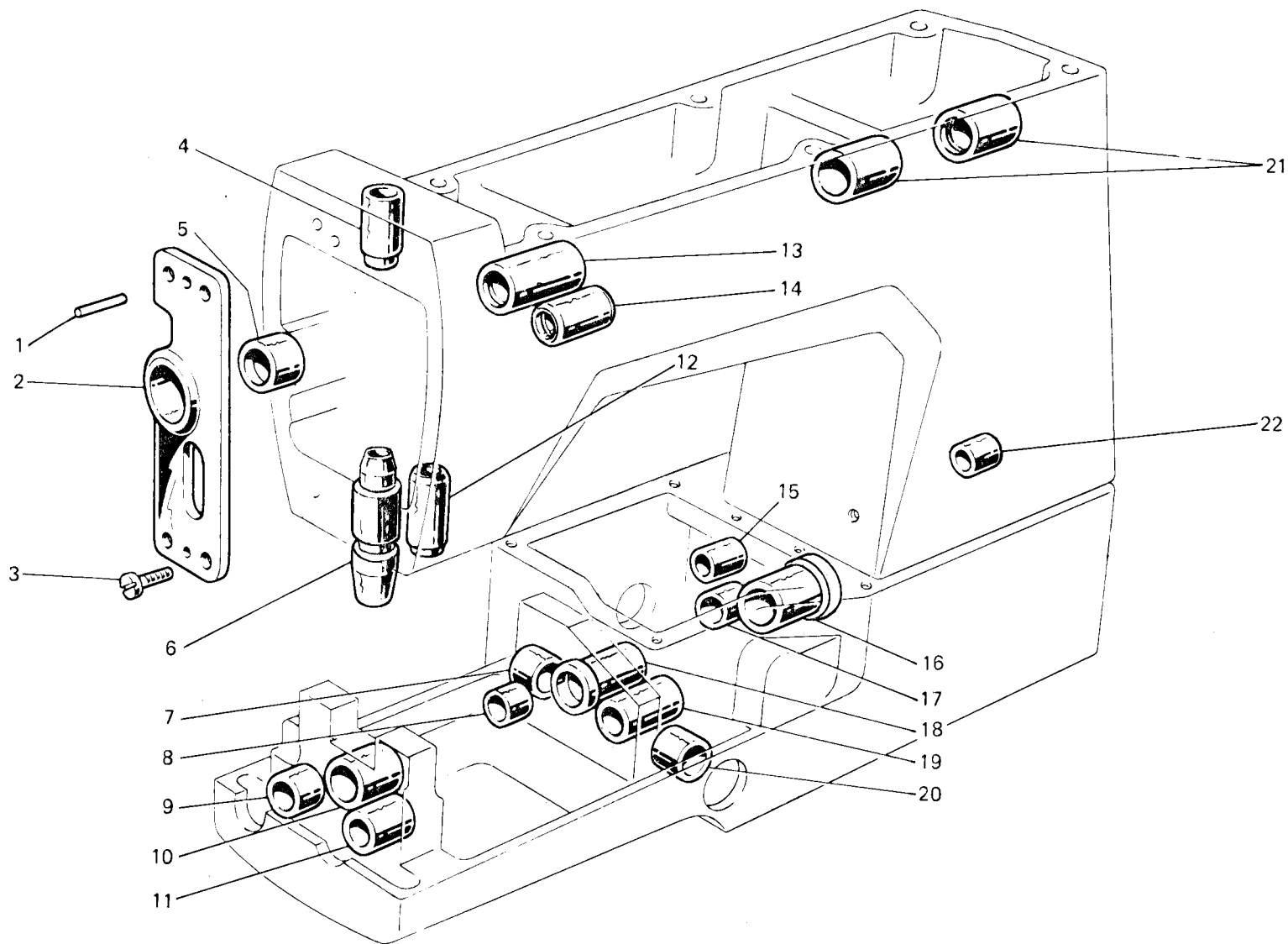


Fig. N. Abb. N.	Part. N. Bestell N. Pieza N.	Qt. Anzahl	DESCRIZIONE	DESCRIPTION	DESCRIPTION	BENENNUNG	DESCRIPCION
1	706454-0-00	2	spina	pin		goupille	
2	308859-2-00	1	supporto con bussola fig. 5	support with bush fig. 5		support avec bague fig.5	
3	722084-2-00	4	vite	screw		vis	
4	308032-0-00	1	bussola	bush		bague	
5	308858-0-00	1	bussola	bush		bague	
6	308411-0-00	1	bussola	bush		bague	
7	311007-0-00	1	bussola	bush		bague	
8	311180-0-00	1	bussola	bush		bague	
9	311168-0-00	1	bussola	bush		bague	
10	311003-0-00	1	bussola	bush		bague	
11	311008-0-00	1	bussola	bush		bague	
12	308031-0-00	1	bussola	bush		bague	
13	308852-0-00	1	bussola	bush		bague	
14	308232-0-00	1	bussola	bush		bague	
15	311116-0-00	1	bussola	bush		bague	
16	308086-0-10	1	bussola	bush		bague	
17	311009-0-00	1	bussola	bush		bague	
18	311004-0-10	1	bussola	bush		bague	
19	308298-0-00	1	bussola	bush		bague	
20	311006-0-00	1	bussola	bush		bague	
21	308853-0-00	2	bussola	bush		bague	
22	311167-0-00	1	bussola	bush		bague	

**538-40 / 561-40 / 563-40**

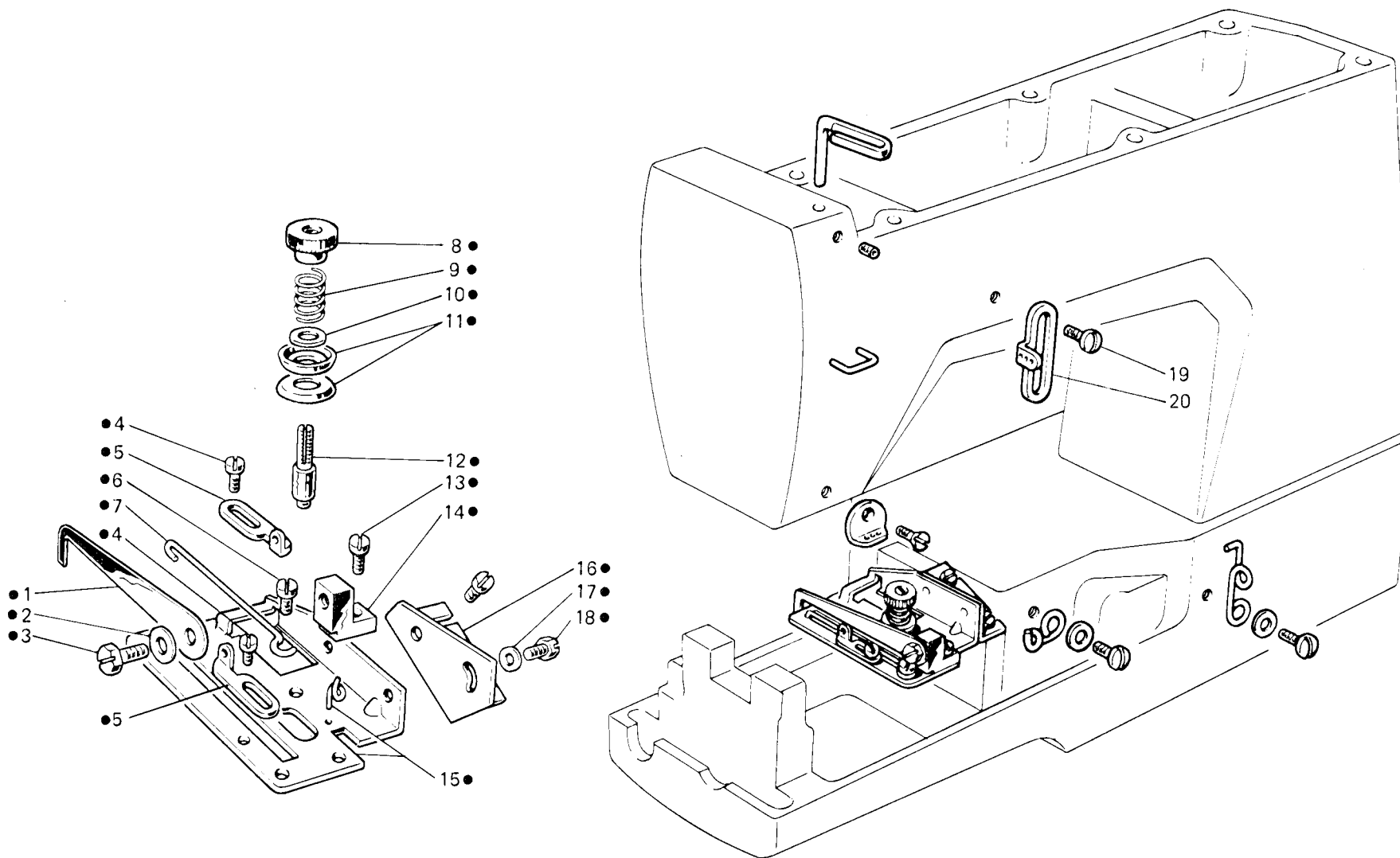




Fig. N. Abb. N.	Part. N. Bestell N. Piece N. Pieza N.	Ct. Anzahl	DESCRIZIONE	DESCRIPTION	DESCRIPTION	BENENNUNG	DESCRIPCION
●	924394-4-01	1	gruppo tensione crochet inf.	lower looper tension ass.	groupe tension crochet inf.		
1	308556-0-00	1	astina	rod	tige		
2	705201-0-00	1	rondella	washer	rondelle		
3	740220-2-00	1	vite	screw	vis		
4	741413-2-00	2	vite	screw	vis		
5	302172-0-10	2	passafilo	thread guide	passe-fil		
6	741612-2-00	1	vite	screw	vis		
7	308558-0-00	1	traversino	tie	traverse		
8	302204-0-10	1	pomolo	knob	pommeau		
9	300310-0-10	1	molla	spring	ressort		
10	704218-2-00	1	rondella	washer	rondelle		
11	200324-0-10	2	disco tensione	tension disc	disque tension		
12	300391-0-10	1	perno a vite	threaded pin	pivot à vis		
13	741642-2-00	1	vite	screw	vis		
14	302168-2-10	1	supporto	support	support		
15	924395-2-01	1	piastra	plate	plaque		
16	311188-0-00	1	squadretta	bracket	équerre		
17	704104-2-00	2	rondella	washer	rondelle		
18	740210-2-00	2	vite	screw	vis		
19	303045-0-10	1	vite	screw	vis		
20	308203-0-01	1	guidafilo	thread guide	guide-fil		

**538-40 / 561-40 / 563-40**

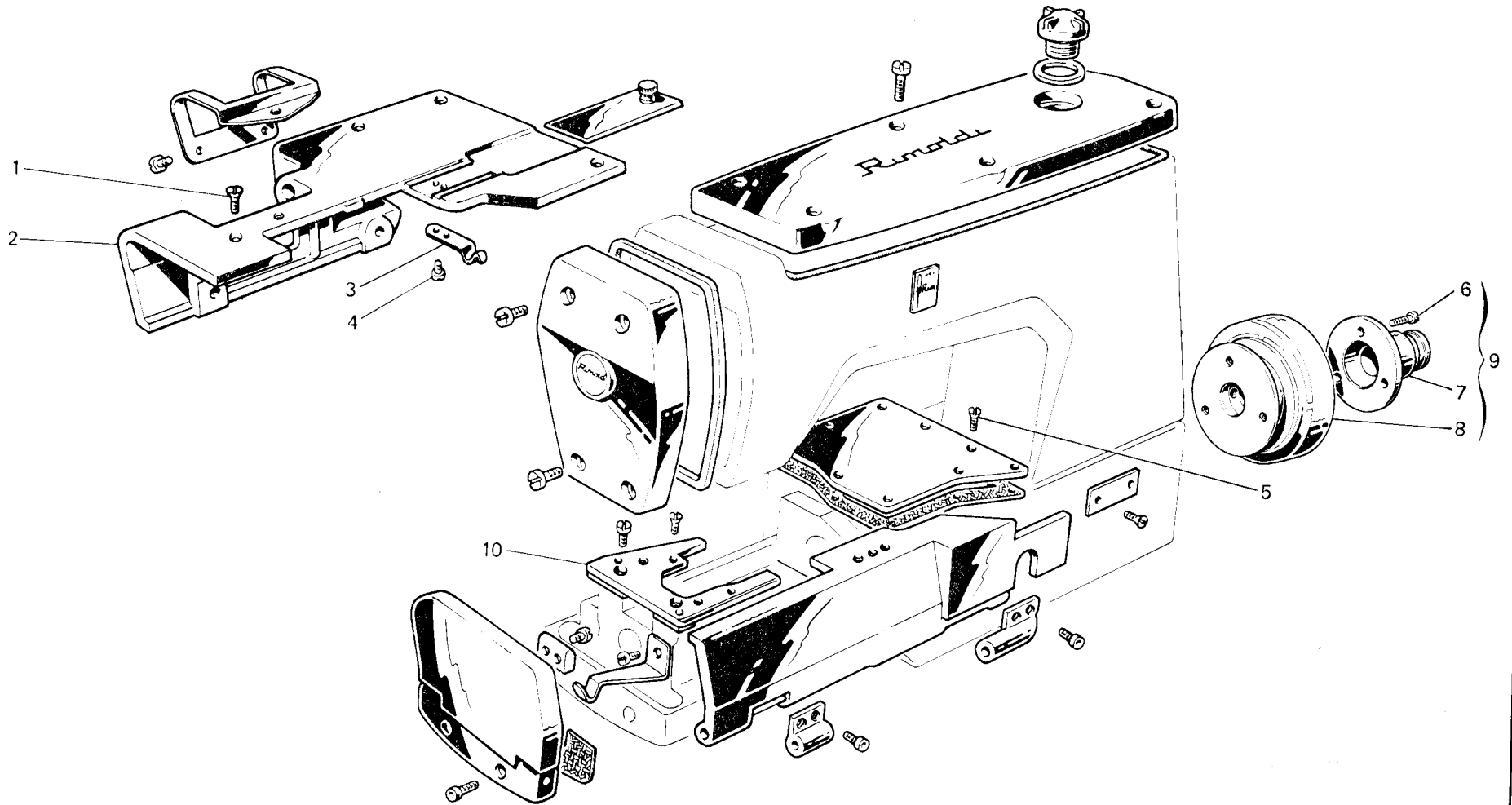


Fig. N. Abb. N.	Part. N. Bestell N. Piece N. Pieza N.	Ct. Anzahl	DESCRIZIONE	DESCRIPTION	DESCRIPTION	BENENNUNG	DESCRIPCION
			SOLO PER TESTA	ONLY FOR HEAD 171-11-2MK-04	SEULEMENT POUR TETE		
1	744636-2-00	1	vite	screw	vis		
2	924446-3-00	1	piano di lavoro (con fig.3-4)	working plate(with fig.3-4)	plan de travail (avec fig.3-4)		
3	311242-0-00	1	molla	spring	ressort		
4	742812-2-00	2	vite	screw	vis		
5	724462-2-00	2	vite	screw	vis		
6	741974-2-00	3	vite	screw	vis		
7	302247-0-10	1	flangia	flange	flasque		
8	924365-0-01	1	volantino	handwheel	volant		
9	924405-4-01	1	volantino completo	handwheel assembly	volant complet		
			PEZZI ANNULLATI	CANCELLED PARTS	PIECES ANNULLEES		
10	311226-2-00	1	piastra porta placca	plate	plaque		

**538-40**

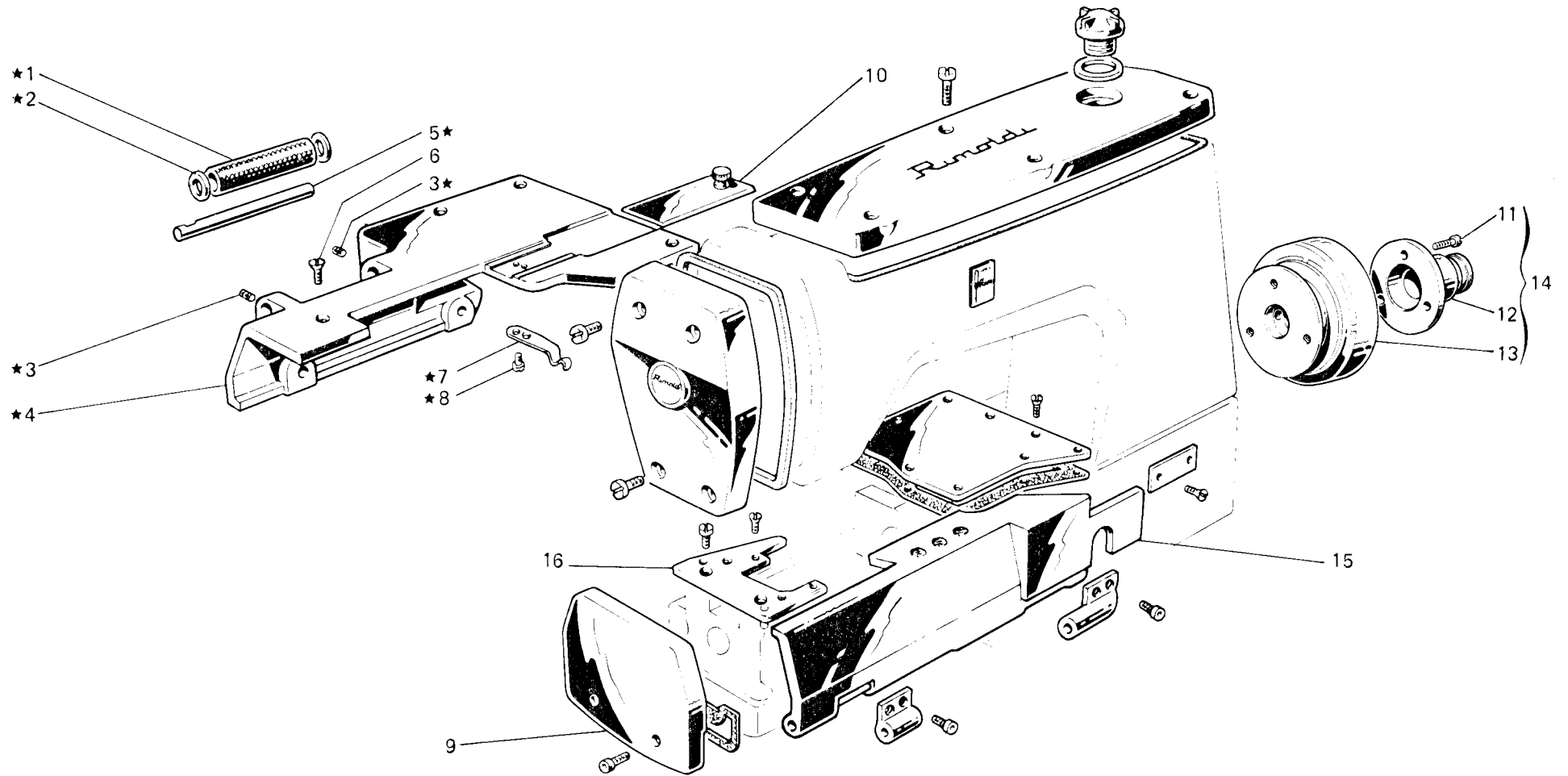


Fig. N. Abb. N.	Part. N. Piece N. Bestell N. Pieza N.	Qt. Anzahl	DESCRIZIONE	DESCRIPTION	DESCRIPTION	BENENNUNG	DESCRIPCION
			SOLO PER TESTA	ONLY FOR HEAD 171-10-3MK-01	SEULEMENT SUR DEMANDE		
★	924426-4-00	1	piano di lavoro completo	working plate assembly	plan de travail complet		
1	311197-3-00	1	ruzzo	roller	rouleau		
2	309562-0-00	2	rondella	washer	rondelle		
3	729012-2-00	2	vite	screw	vis		
4	924475-0-00	1	piano di lavoro	working plate	plan de travail		
5	311184-0-00	1	perno	pin	pivot		
6	744636-2-00	1	vite	screw	vis		
7	311242-0-00	1	molla	spring	ressort		
8	742812-2-00	2	vite	screw	vis		
9	924432-0-00	1	carter laterale	side cover	carter latéral		
10	309312-2-00	1	coperchio scorrevole	sliding cover	couvercle coulissant		
11	741974-2-00	3	vite	screw	vis		
12	302247-0-10	1	flangia	flange	flasque		
13	924365-0-01	1	volantino	handwheel	volant		
14	924422-4-00	1	volantino completo	handwheel assembly	volant complet		
15	311258-3-00	1	carter anteriore	front cover	carter avant		
			SOLO A RICHIESTA	ONLY ON REQUEST	SEULEMENT SUR DEMANDE		
★	924425-4-00	1	piano di lavoro completo	working plate assembly	plan de travail complet		
1	311181-3-00	1	ruzzo	roller	rouleau		
			PEZZI ANNULLATI	CANCELLED PARTS	PIECES ANNULEES		
16	311226-2-00	1	piastra porta placca	plate	plaque		

538-40

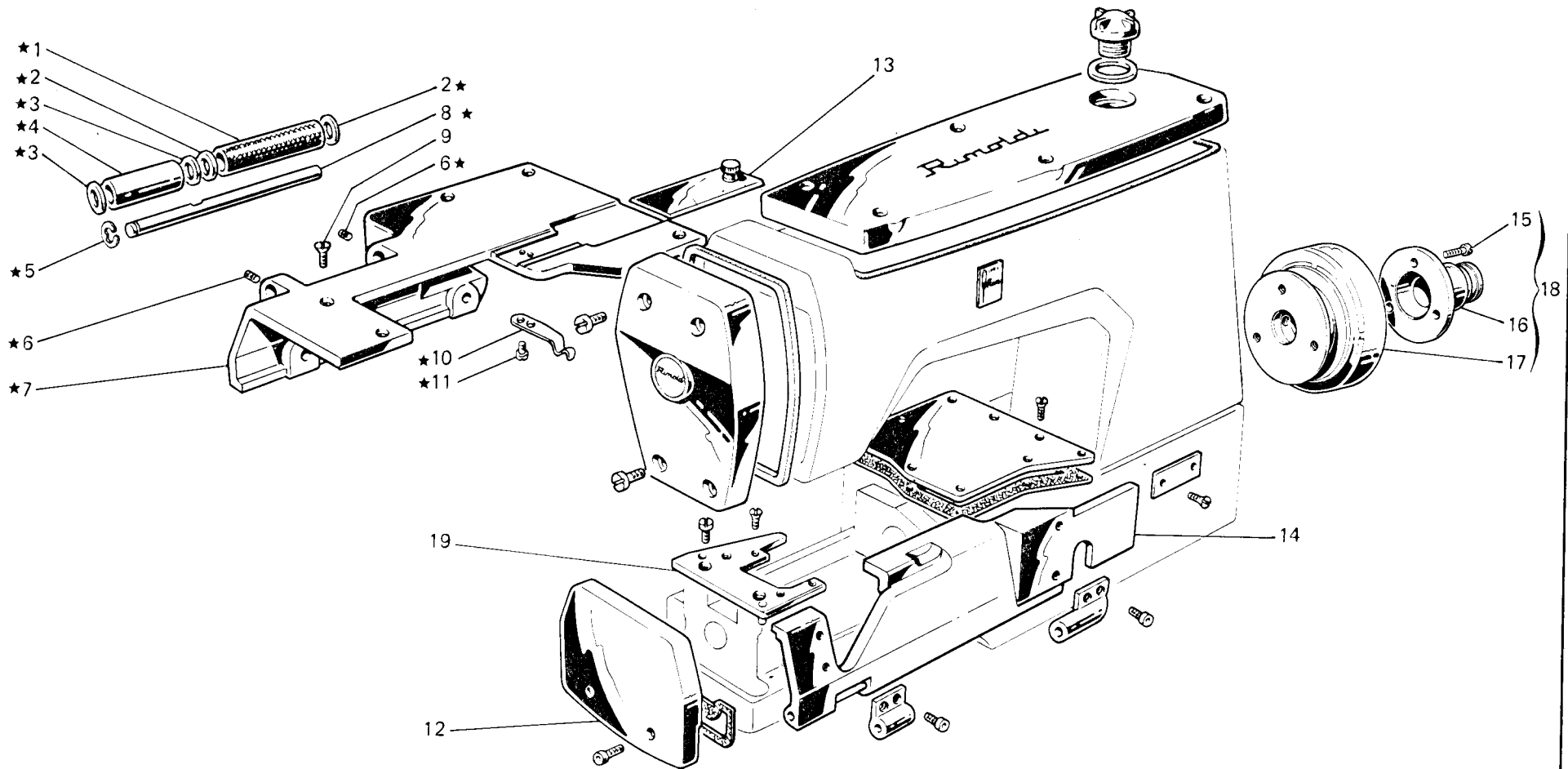


Fig. N. Abb. N.	Part. N. Bestell N. Piece N. Pieza N.	Qt. Anzahl	DESCRIZIONE	DESCRIPTION	DESCRIPTION	BENENNUNG	DESCRIPCION
			SOLO PER TESTA	ONLY FOR HEAD 171-16-3MK-01	SEULEMENT POUR TETE		
★	924424-4-00	1	piano di lavoro completo	working plate assembly	plan de travail complet		
1	311197-3-00	1	rullo	roller	rouleau		
2	309562-0-00	2	rondella	spring	rondelle		
3	311408-0-00	2	rondella	spring	rondelle		
4	311407-0-00	1	rullo	roller	rouleau		
5	700210-0-00	1	anello di tenuta	spring ring	anneau ressort		
6	729012-2-00	2	vite	screw	vis		
7	924475-0-00	1	piano di lavoro	working plate assembly	plan de travail complet		
8	311406-0-00	1	perno	pin	pivot		
9	744636-2-00	1	vite	screw	vis		
10	311242-0-00	1	molla	spring	ressort		
11	742812-2-00	2	vite	screw	vis		
12	924432-0-00	1	carter laterale	side cover	carter latéral		
13	309312-2-00	1	coperchio scorrevole	sliding cover	couvercle coulissant		
14	924399-3-00	1	carter anteriore	front cover	carter avant		
15	741974-2-00	3	vite	screw	vis		
16	302247-0-10	1	flangia	flange	flasque		
17	924365-0-01	1	volantino	handwheel	volant		
18	924422-4-00	1	volantino completo	handwheel assembly	volant complet		
			PEZZI ANNULLATI	CANCELLED PARTS	PIECES ANNULLEES		
19	311226-2-00	1	piastra porta placca	plate	plaque		

**561-40 / 563-40**

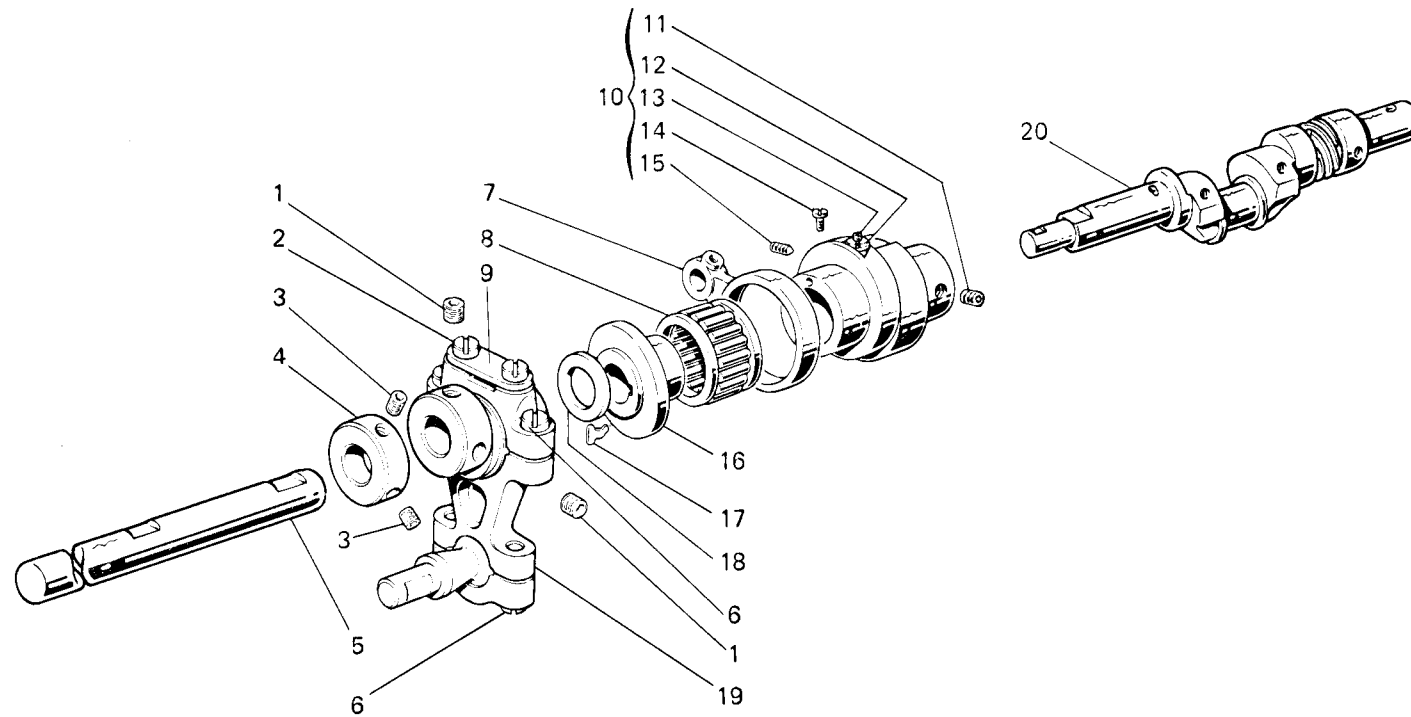




Fig. N. Abb. N.	Part. N. Bestell N. Piece N. Pieza N.	Qt. Anzahl	DESCRIZIONE	DESCRIPTION	DESCRIPTION	BENENNUNG	DESCRIPCION
—	311364-4-20	1	gruppo albero inferiore	lower shaft assembly	groupe arbre inférieur		
1	745815-2-00	2	vite	screw	vis		
2	741925-2-00	2	vite	screw	vis		
3	745124-0-00	2	vite	screw	vis		
4	314169-0-00	1	anello	ring	anneau		
5	311088-2-20	1	semialbero inferiore sinistro	left lower half-shaft	semi-arbre inférieur gauche		
6	308802-0-00	4	vite per biella	screw for con-rod	vis pour bielle		
7	311105-0-00	1	biella comando trasporto	transport control con-rod	bielle commande transport		
8	311186-0-00	1	gabbia a rullini	needles cage	cage à aiguilles		
9	313026-0-02	1	forcellina	fork	fourche		
10	311015-4-02	1	eccentrico reg. trasporto	eccentric	excentrique		
11	729024-2-00	4	vite	screw	vis		
12	206603-0-10	1	fermo	eccentric retainer	pièce blocage excentrique		
13	729051-2-00	1	vite	screw	vis de blocage		
14	202473-0-11	2	vite	screw	vis		
15	730011-2-00	2	vite	screw	vis		
16	311022-0-01	1	eccentrico	eccentric	excentrique		
17	206872-0-00	1	molla	spring	ressort		
18	704852-0-00	1	rondella	washer	rondelle		
19	313156-4-00	1	biella completa	con-rod assembly	bielle complète		
20	311190-3-02	1	semialbero inf. destro	right lower half-shaft	semi-arbre inférieur droite		

# 561-40 / 563-40

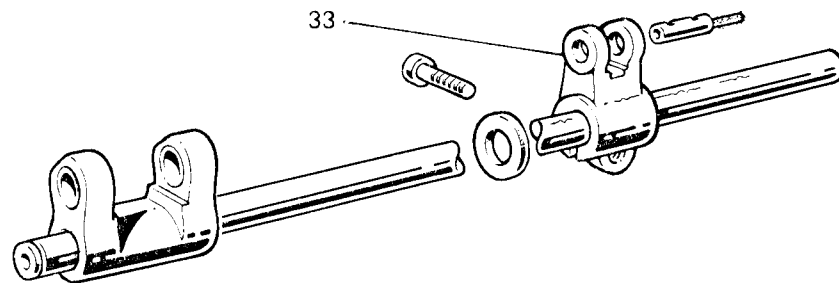
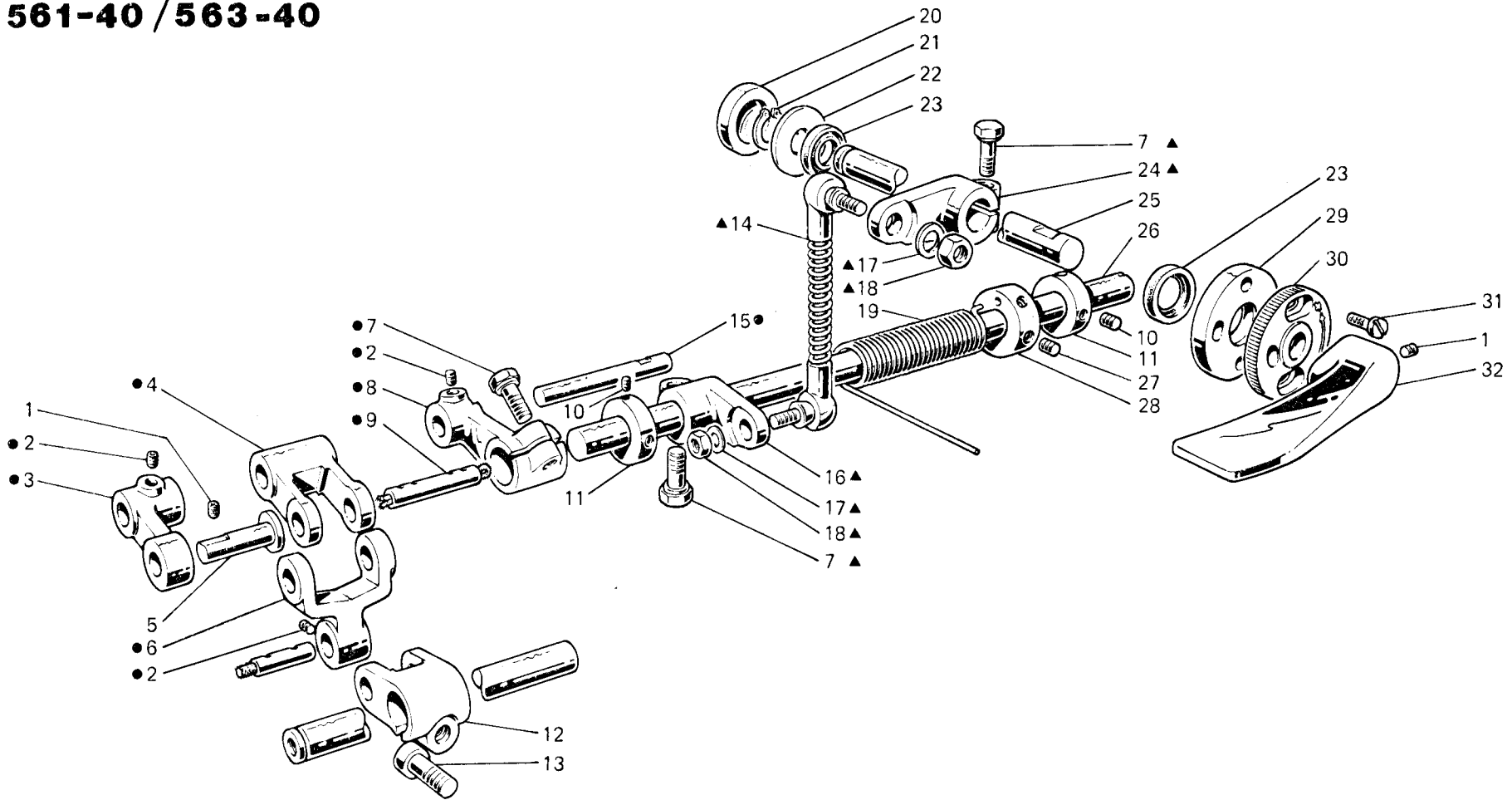


Fig. N. Abb. N.	Part. N. Bestell N. Piece N. Pieza N.	Qt. Anzahl	DESCRIZIONE	DESCRIPTION	DESCRIPTION	BENENNUNG	DESCRIPCION
▲	311079-4-00	1	gruppo tirante	tie-rod assembly	groupe tirant		
●	311078-4-00	1	gruppo braccio oscillante	oscillating arm assembly	groupe bras oscillant		
1	729013-2-00	1	vite	screw	vis		
2	745811-2-00	3	vite	screw	vis		
3	311113-2-00	1	braccio con vite	arm with screw	bras avec vis		
4	311108-0-00	1	braccio oscillante	arm	bras		
5	311117-0-00	1	perno	pin	pivot		
6	311107-2-00	1	giunto con vite	joint with screw	joint avec vis		
7	202502-0-10	3	vite	screw	vis		
8	311112-2-01	1	braccio con vite	arm with screw	bras avec vis		
9	311250-2-00	1	perno con stoppini	pin with wicks	pivot avec mèches		
10	745812-2-00	4	vite	screw	vis		
11	206606-2-00	2	anello di registro con viti	adjustment ring with screws	bague d'étanchéité avec vis		
12	311110-2-00	1	braccio a forcella con vite	fork arm with screw	bras à fourche avec vis		
13	744332-2-00	1	vite	screw	vis		
14	311300-3-01	1	tirante completo	tie-rod assembly	tirant complet		
15	311114-0-00	1	perno	pin	pivot		
16	311131-2-00	1	braccio con vite	arm with screw	bras avec vis		
17	704309-4-00	2	rondella	washer	rondelle		
18	746020-2-00	2	dado	nut	écrou		
19	311133-0-00	1	molla	spring	ressort		
20	311036-0-00	1	tappo	plug	bouchon		
21	700010-0-00	1	anello di fermo	spring ring	anneau ressort		
22	704240-2-00	1	rondella	washer	rondelle		
23	304763-0-10	2	anello di tenuta	retainer ring	bague d'étanchéité		
24	311135-2-00	1	braccio con vite	arm with screw	bras avec vis		
25	311128-0-00	1	perno	pin	pivot		
26	311115-0-00	1	albero	shaft	arbre		
27	729012-2-00	2	vite	screw	vis		
28	311134-2-00	1	anello con viti	ring with screws	anneau avec vis		
29	311132-0-00	1	flangia	flange	flasque		
30	311127-0-00	1	flangia limitatrice	flange	flasque		
31	741056-0-00	2	vite	screw	vis		
32	311126-2-00	1	tasto con viti	push-button with screws	touche avec vis		
			PEZZI ANNULLATI	CANCELLED PARTS	PIECES ANNULLEES		
33	311053-2-00	1	braccio forcella con vite	fork arm with screws	bras fourche avec vis		

538-40

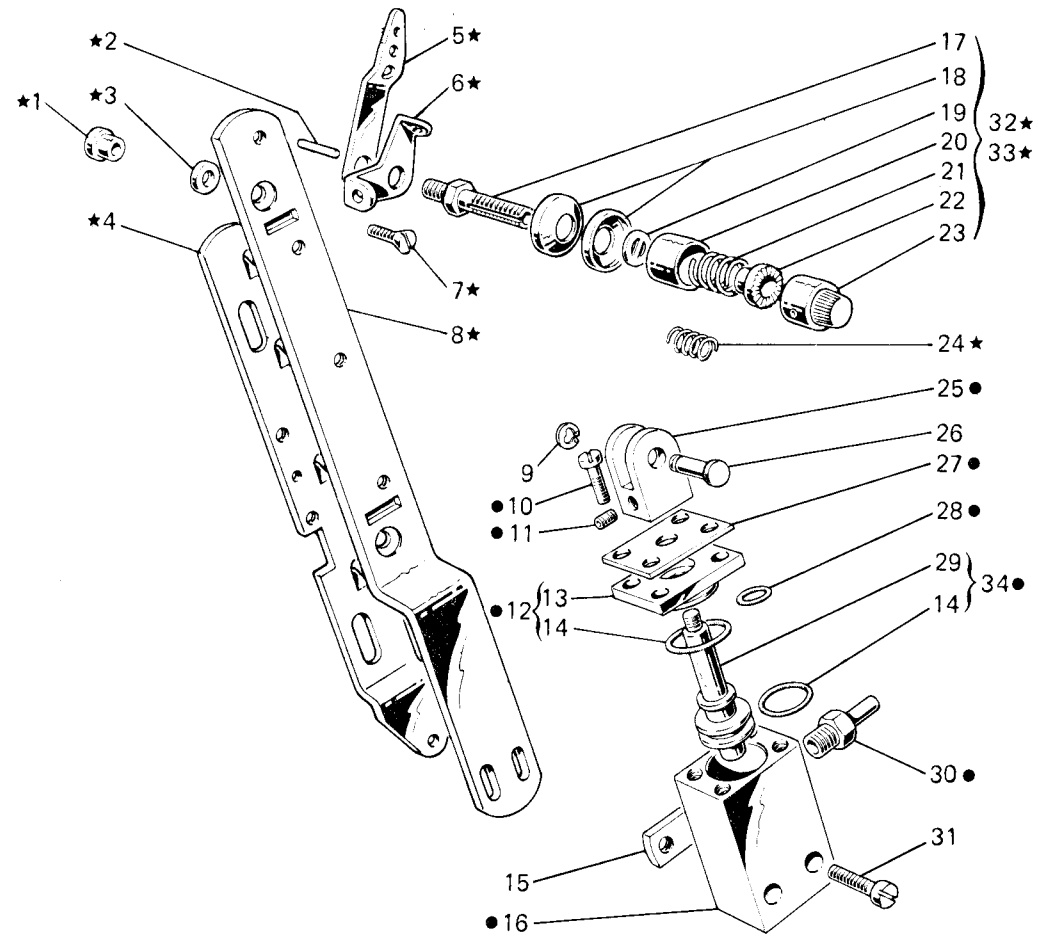


Fig. N. Abb. N.	Part. N. Bestell N. Piece N. Pieza N.	Qt. Anzahl	DESCRIZIONE	DESCRIPTION	DESCRIPTION	BENENNUNG	DESCRIPCION
★	926661-4-00	1	gruppo tensioni	tensions assembly	groupe tensions		
●	924735-4-12	1	valvola completa	valve assembly	soupape compl.		
1	308512-0-00	2	distanziale	spacer	entretoise		
2	308506-0-00	3	pernetto	pin	pivot		
3	701405-0-00	2	anello	ring	anneau		
4	924416-0-00	1	slitta per tensione	slide for tension	glissière for tension		
5	308501-0-01	3	passafilo	thread guide	passé-fil		
6	308503-0-01	3	guidafilo	thread guide	guide-fil		
7	744676-2-00	2	vite	screw	vis		
8	926657-0-00	1	supporto	support	support		
9	700205-0-00	1	anello elastico	spring ring	anneau ressort		
10	741495-2-00	4	vite	screw	vis		
11	745800-2-00	1	vite	screw	vis		
12	926669-4-01	1	flangia con anello di tenuta	flange	flasque		
13	924736-0-21	1	flangia	flange	flasque		
14	701009-0-00	2	anello di tenuta	retainer ring	anneau ressort		
15	924740-0-10	1	piastrina	plate	plaque		
16	924734-0-20	1	corpo	body	corps		
17	308505-0-00	3	perno a vite	threaded pin	pivot à vis		
18	300218-0-10	6	disco tensione	tension disc	disque tension		
19	308507-0-00	3	rondella	washer	rondelle		
20	202556-0-00	3	scodellino	cup	cuvette		
21	200710-0-10	2	molla	spring	ressort		
22	202229-0-10	3	bussola superiore	upper bush	bague supérieure		
23	202558-2-00	3	pomolo	knob	pommeau		
24	200714-0-10	1	molla	spring	ressort		
25	924739-0-10	1	forcella	fork	fourche		
26	202100-0-10	1	perno	pin	pivot		
27	924745-0-20	1	coperchio	cover	couvercle		
28	701104-0-00	1	anello di tenuta	retainer ring	anneau ressort		
29	924737-0-21	1	pistone	piston	piston		
30	924701-0-11	2	attacco per tubetto	pipe union	raccord pour tube		
31	721086-2-00	2	vite	screw	vis		
32	308518-4-00	2	tensione sup. con molla fig. 21	upper tension with spring fig. 21	tension sup. avec ressort fig. 21		
33	308521-4-00	1	tensione inf. con molla fig. 24	lower tension with spring fig. 24	tension inf. avec ressort fig. 24		
34	924738-4-21	1	pistone con anello di tenuta	piston with retainer ring	piston avec bague d'étanchéité		
			VARIANTE PER	VARIATION FOR	VARIANTE POUR		
				171-10-3MK-01 / 171-16-3MK-01			
★	926660-4-00	1	gruppo tensioni	tensions assembly	groupe tensions		
2	308506-0-00	4	pernetto	pin	pivot		
5	308501-0-01	4	passafilo	thread guide	passé-fil		
6	308503-0-01	4	guidafilo	thread guide	guide-fil		
17	308505-0-00	4	perno a vite	threaded pin	pivot à vis		
18	300218-0-10	8	disco tensione	tension disc	disque tension		
19	308507-0-00	4	rondella	washer	rondelle		
20	202556-0-00	4	scodellino	cup	cuvette		
21	200710-0-10	3	molla	spring	ressort		
22	202229-0-10	4	bussola superiore	upper bush	bague supérieure		
23	202558-2-00	4	pomolo	knob	pommeau		
32	308518-4-00	3	tensione sup. con molla fig. 21	upper tension with spring fig. 21	tension sup. avec ressort fig. 21		

561-40 / 563-40

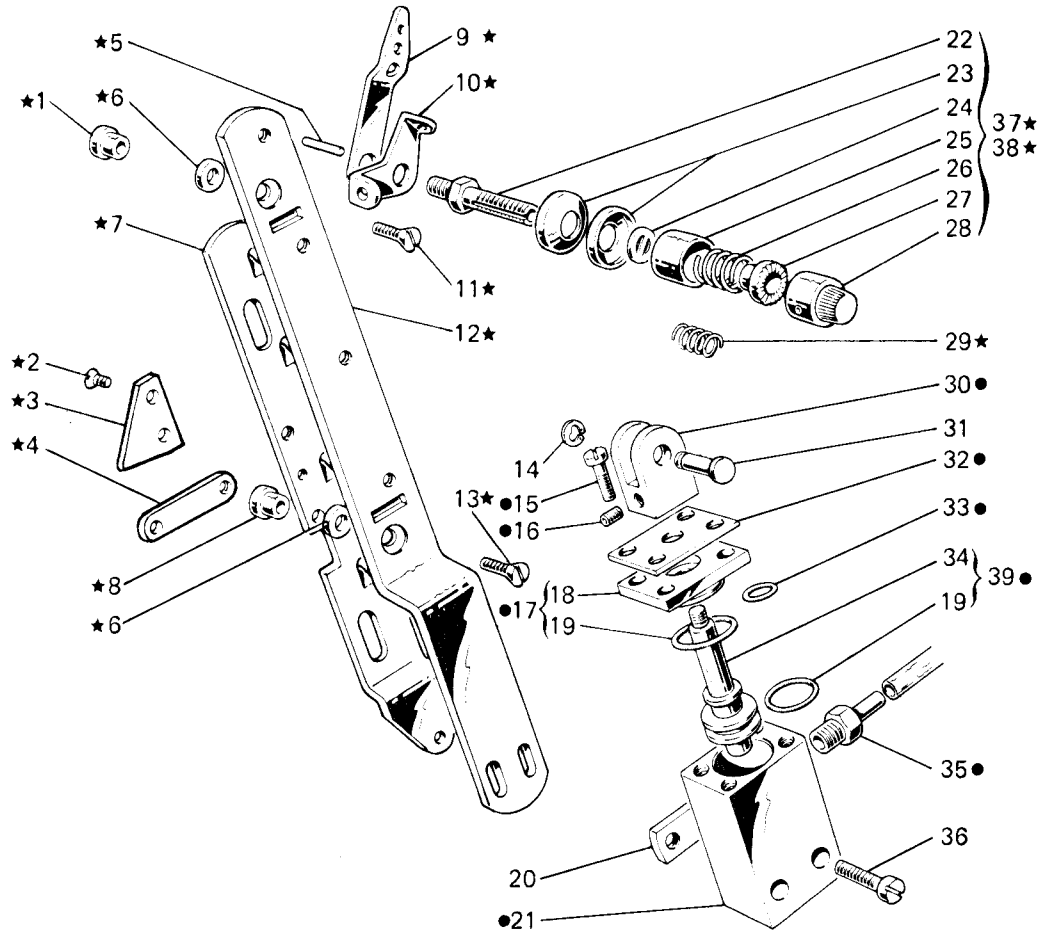


Fig. N. Abb. N.	Part. N. Bestell. N. Piece N. Pieza N.	Qt. Anzahl	DESCRIZIONE	DESCRIPTION	DESCRIPTION	BENENNUNG	DESCRIPCION
★	924411-4-00	1	gruppo tensioni	tensions assembly	groupe tensions		
●	924735-4-12	1	valvola completa	valve assembly	soupape compl.		
1	924419-0-00	1	distanziale	spacer	entretoise		
2	724422-2-00	2	vite	screw	vis		
3	924417-0-00	1	piastrina	plate	plaque		
4	924418-0-00	1	piastrina	plate	plaque		
5	308506-0-00	3	pernetto	pin	pivot		
6	701405-0-00	2	anello	ring	anneau		
7	924416-0-00	1	slitta per tensione	slide for tension	glissière for tension		
8	308512-0-00	1	distanziale	spacer	entretoise		
9	308501-0-01	3	passafilo	thread guide	passe-fil		
10	308503-0-01	3	guidafilo	thread guide	guide-fil		
11	744696-2-00	1	vite	screw	vis		
12	926657-0-00	1	supporto	support	support		
13	744567-2-00	1	vite	screw	vis		
14	700205-0-00	1	anello elastico	spring ring	anneau ressort		
15	741495-2-00	4	vite	screw	vis		
16	745800-2-00	1	vite	screw	vis		
17	926669-4-01	1	flangia con anello di tenuta	flange	flasque		
18	924736-0-21	1	flangia	flange	flasque		
19	701009-0-00	2	anello di tenuta	retainer ring	anneau ressort		
20	924740-0-10	1	piastrina	plate	plaque		
21	924734-0-20	1	corpo	body	corps		
22	308505-0-00	3	perno a vite	threaded pin	pivot à vis		
23	300218-0-10	6	disco tensione	tension disc	disque tension		
24	308507-0-00	3	rondella	washer	rondelle		
25	202556-0-00	3	scodellino	cup	cuvette		
26	200710-0-10	2	molla	spring	ressort		
27	202229-0-10	3	bussola superiore	upper bush	bague supérieure		
28	202558-2-00	3	pomolo	knob	pommeau		
29	200714-0-10	1	molla	spring	ressort		
30	924739-0-10	1	forcella	fork	fourche		
31	202100-0-10	1	perno	pin	pivot		
32	924745-0-20	1	coperchio	cover	couvercle		
33	701104-0-00	1	anello di tenuta	retainer ring	anneau ressort		
34	924737-0-21	1	pistone	piston	piston		
35	924701-0-11	2	attacco per tubetto	pipe union	raccord pour tube		
36	721086-2-00	2	vite	screw	vis		
37	308518-4-00	2	tensione sup. con molla fig. 26	upper tension with spring fig. 26	tension sup. avec ressort fig. 26		
38	308521-4-00	1	tensione inf. con molla fig. 29	lower tension with spring fig. 29	tension inf. avec ressort fig. 29		
39	924738-4-21	1	pistone con anello di tenuta	piston with retainer ring	piston avec bague d'étanchéité		

# 538-40 / 561-40 / 563-40

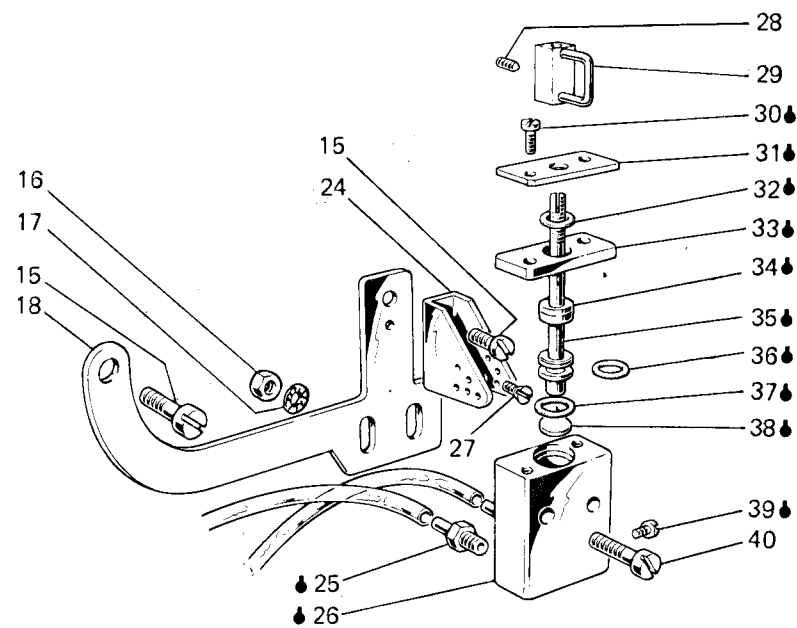
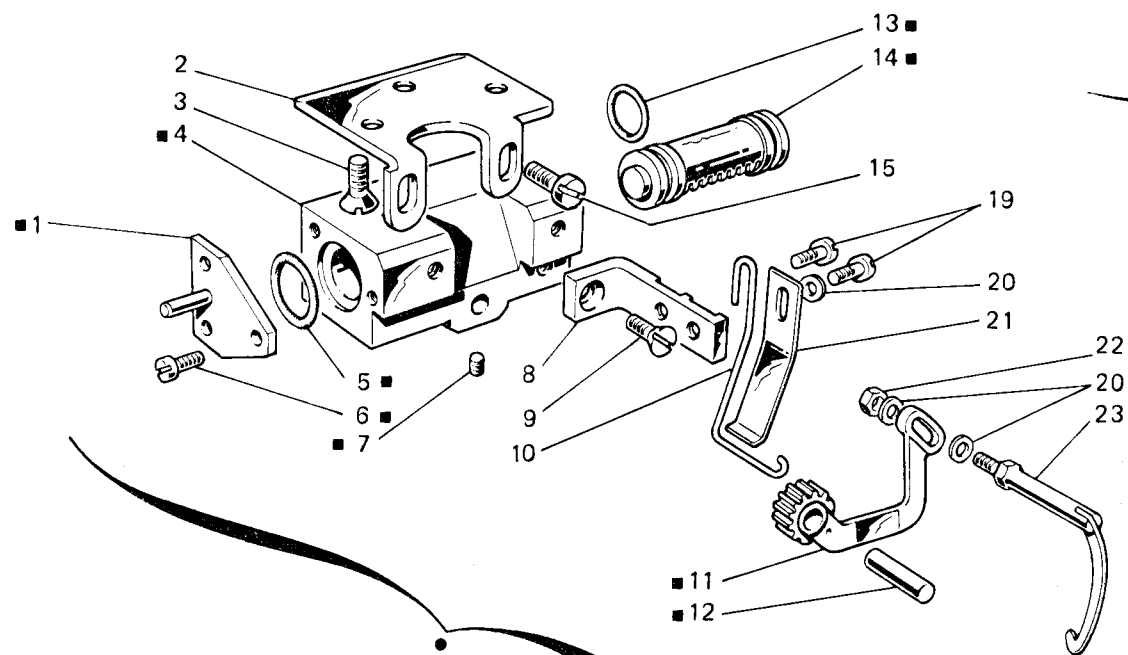




Fig. N. Abb. N.	Part. N. Bestell N. Piese N. Pieza N.	Qt. Anzahl	DESCRIZIONE	DESCRIPTION	DESCRIPTION	BENENNUNG	DESCRIPCION
●	924350-5-10	1	appinzatore completo (escluso figg. 2-3-15)	gripping device assembly excluded figs 2-3-15)	dispositif pinceur complet (exclu figs 2-3-15)		
■	924384-4-11	1	cilindro completo	cylinder assembly	cylindre complet		
▲	924723-5-12	1	tirafilo completo (escluso fig. 15)	thread take-up (excluded fig. 15)	tendeur du fil (exclu fig. 15)		
●	924059-4-00	1	valvola completa	valve assembly	soupape complète		
1	924387-2-00	2	coperchio con raccordo	cover	couvercle		
2	924355-0-00	1	squadretta	bracket	équerre		
3	725612-2-00	3	vite	screw	vis		
4	924351-0-10	1	corpo	body	corps		
5	701017-0-00	2	anello di tenuta	retainer ring	bague d'étanchéité		
6	741634-2-00	6	vite	screw	vis		
7	745800-2-00	1	vite	screw	vis		
8	924352-0-00	1	supporto	support	support		
9	724441-0-00	1	vite	screw	vis		
10	924353-0-10	1	molla	spring	ressort		
11	924369-2-10	1	leva con pignone	lever	levier		
12	924356-0-10	1	perno	pin	pivot		
13	701009-0-00	2	anello di tenuta	retainer ring	bague d'étanchéité		
14	924367-2-11	1	pistone con anelli di tenuta	piston	piston		
15	741936-2-00	4	vite	screw	vis		
16	703505-0-00	2	rondella dentellata	washer	rondelle		
17	733505-2-00	2	dado	nut	écrou		
18	924727-0-20	1	sostegno	support	support		
19	741634-2-00	2	vite	screw	vis		
20	704302-4-00	3	rondella	washer	rondelle		
21	924354-0-00	1	lamina	sheet	plaque		
22	746002-2-00	1	dado	nut	écrou		
23	924366-2-10	1	gancio	hook	crochet		
24	924729-0-10	1	passafilo	thread guide	passe-fil		
25	924701-0-11	2	attacco	pipe union	raccord		
26	924049-0-00	1	corpo	body	corps		
27	724411-0-00	1	vite	screw	vis		
28	745810-5-00	1	vite	screw	vis		
29	924980-2-10	1	tendifilo	thread take-up	tendeur du fil		
30	722070-2-00	2	vite	screw	vis		
31	924047-0-00	1	coperchietto	cover	couvercle		
32	701003-0-00	1	anello di tenuta	retainer ring	bague d'étanchéité		
33	924048-0-00	1	coperchio	cover	couvercle		
34	924402-0-00	1	ammortizzatore	damper	amortisseur		
35	924046-0-00	1	pistoncino	piston	piston		
36	701007-0-00	1	anello di tenuta	retainer ring	bague d'étanchéité		
37	701004-0-00	1	anello di tenuta	retainer ring	bague d'étanchéité		
38	924045-0-00	1	ammortizzatore	damper	amortisseur		
39	741303-4-00	3	tappo a vite	plug	bouchon		
40	722123-2-00	2	vite	screw	vis		

**538-40 / 561-40 / 563-40**

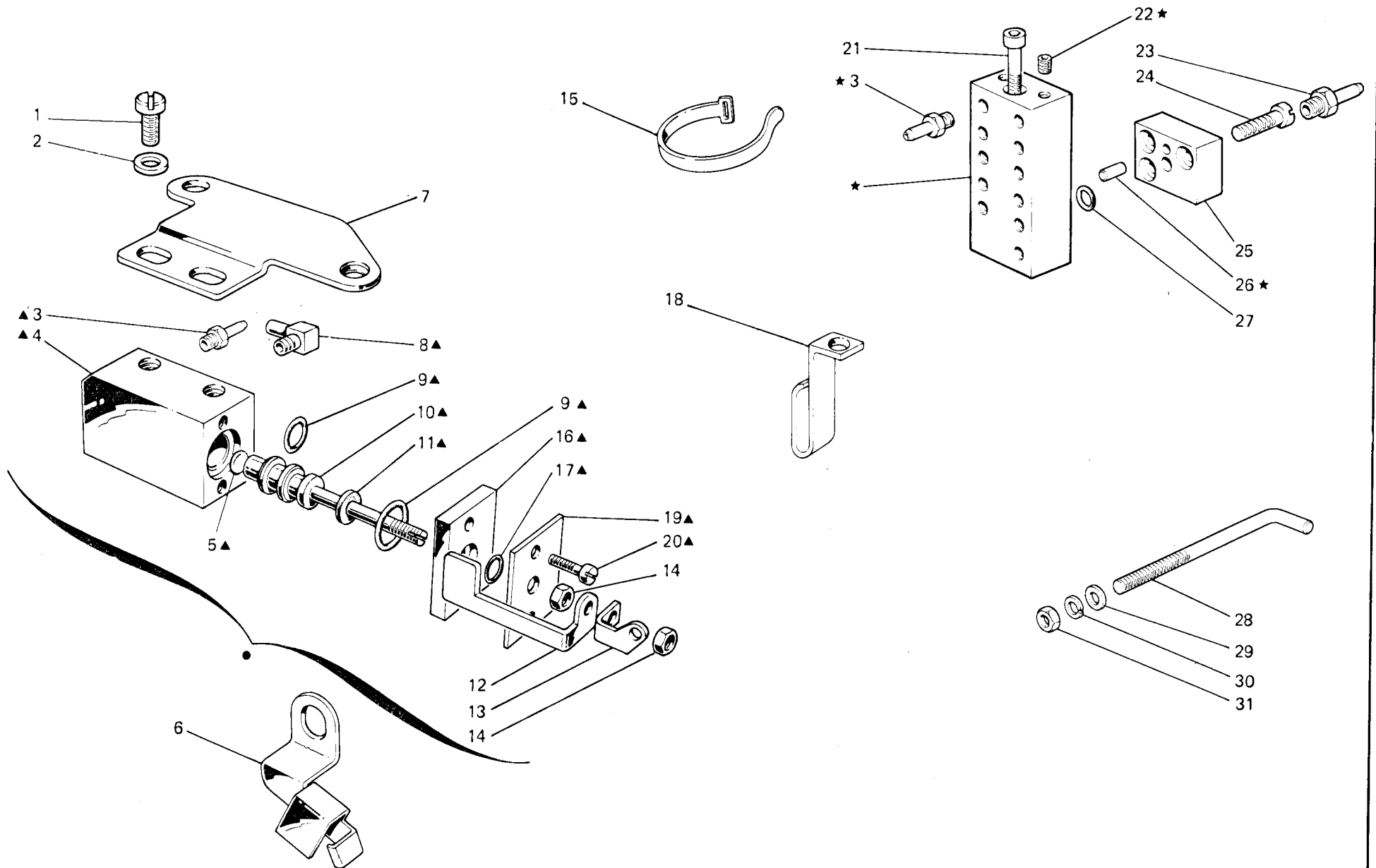


Fig. N. Abb. N.	Part. N. Bestell N. Piece N. Pieza N.	Qt. Anzahl	DESCRIZIONE	DESCRIPTION	DESCRIPTION	BENENNUNG	DESCRIPCION
●	924044-4-00	1	gruppo tirafilo	thread take-up assembly		groupe tendeur du fil	
▲	924030-4-00	1	valvola completa	valve assembly		soupape complète	
★	944764-2-00	1	distributore completo	distributor assembly		distributeur complet	
1	741936-2-00	2	vite	screw		vis	
2	704210-4-00	2	rondella	washer		rondelle	
3	924701-0-11	12	attacco	attachment		raccord	
4	924039-0-00	1	corpo	body		corps	
5	924045-0-00	1	ammortizzatore	damper		amortisseur	
6	924480-0-00	1	supporto per tubetti	support		support	
7	924483-0-00	1	supporto	support		support	
8	943765-0-01	1	raccordo	pipe connection		raccord	
9	701009-0-00	2	anello di tenuta	retainer ring		bague d'étanchéité	
10	924031-0-01	1	pistoncino	piston		piston	
11	924731-0-20	1	ammortizzatore	damper		amortisseur	
12	924485-0-10	1	asta	rod		tige	
13	924484-0-10	1	tirafilo	thread take-up		tendeur du fil	
14	733505-2-00	2	dado	nut		écrou	
15	920258-0-10	2	cinturino	strap		bride	
16	924032-0-00	1	flangia	flange		flasque	
17	701003-0-00	1	anello di tenuta	retainer ring		bague d'étanchéité	
18	924497-0-00	1	fascetta	clamp		bride	
19	924033-0-00	1	coperchio	cover		couvercle	
20	722070-2-00	2	vite	screw		vis	
21	722573-2-00	1	vite	screw		vis	
22	729012-2-00	2	vite	screw		vis	
23	927655-0-00	3	attacco	attachment		raccord	
24	722431-2-00	1	vite	screw		vis	
25	944794-2-00	1	presa	socket		prise	
26	707221-0-00	1	spina	pin		goupille	
27	701104-0-00	3	anello di tenuta	retainer ring		bague d'étanchéité	
28	944795-0-00	1	perno posizionale	pin		pivot	
29	704310-2-00	1	rondella	washer		rondelle	
30	703007-0-00	1	rondella elastica	spring washer		rondelle élastique	
31	733507-2-00	1	dado	nut		écrou	
			VARIANTE PER TESTA	VARIATION FOR	VARIANTE POUR		
				171-16-3MK-01			
28	925222-0-00	1	perno posizionale	pin		pivot	

**561-40**

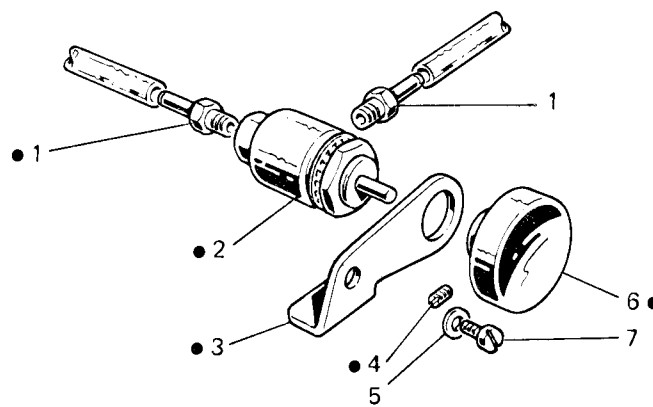


Fig. N. Abb. N.	Part. N. Bestell N. Piece N. Pieza N.	Qt. Anzahl	DESCRIZIONE	DESCRIPTION	DESCRIPTION	BENENNUNG	DESCRIPCION
●	925511.4-00	1	minivalvola completa	valve assembly	soupape complète		
1	924784.0-10	2	attacco	pipe union	raccord		
2	924780.0-10	1	minivalvola	valve	soupape		
3	925510.0-00	1	supporto	support	support		
4	727032.0-00	1	vite	screw	vis		
5	704210.4-00	1	rondella	washer	rondelle		
6	924782.0-10	1	pomolo	knob	pommeau		
7	741937.0-00	1	vite	screw	vis		

563-40

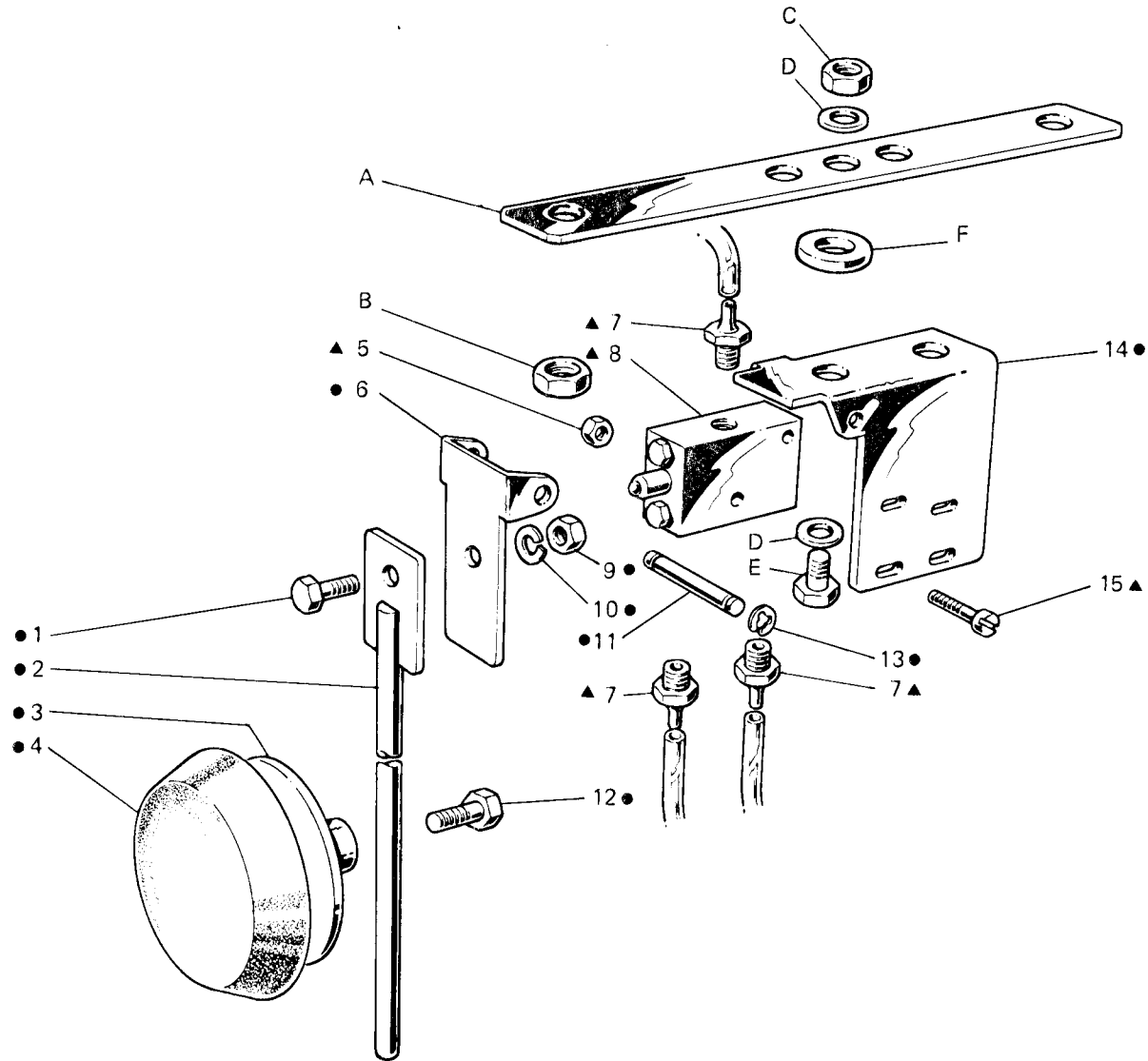


Fig. N. Abb. N.	Part. N. Bestell N. Piece N. Pieza N.	Qt. Anzahl	DESCRIZIONE	DESCRIPTION	DESCRIPTION	BENENNUNG	DESCRIPCION
▲	924922-4-10	1	gruppo ginocchiello (con ●)	knee-press assembly (with ●)	groupe genouillère (avec ●)		
●	924864-4-10	1	ginocchiello completo	knee-press assembly	genouillère compl.		
1	720464-2-00	1	vite	screw	vis		
2	924866-2-10	1	asta	rod	tige		
3	920105-0-10	1	disco	disc	disque		
4	920113-0-10	1	cuscinò	pad	coussin		
5	733505-2-00	2	dado	nut	écrou		
6	924863-0-10	1	piastra mobile	plate	plaque		
7	924870-0-10	3	attacco	pipe union	raccord		
8	924921-0-10	1	valvola	valve	soupape		
9	746203-4-00	1	dado	nut	écrou		
10	703008-0-00	1	rondella	washer	rondelle		
11	924868-0-10	1	perno	pin	pivot		
12	740035-0-00	1	vite	screw	vis		
13	700207-0-00	2	anello elastico	spring ring	anneau ressort		
14	924860-0-10	1	piastra	plate	plaque		
15	722143-2-00	2	vite	screw	vis		
			Solo per bancale a colonna	Only for column stand	Seulement pour bâti a colonne		
A	925785-0-00	1	traversa	tie	traverse		
B	733008-2-00	4	dado	nut	écrou		
C	733510-2-00	1	dado	nut	écrou		
D	704232-2-00	2	rondella	washer	rondelle		
E	720485-4-00	1	vite	screw	vis		
			Solo per bancale regolabile	Only for adjustable stand	Seulement pour bâti réglable		
C	733510-2-00	1	dado	nut	écrou		
D	704232-2-00	2	rondella	washer	rondelle		
E	720485-4-00	2	vite	screw	vis		
F	704346-2-00	1	distanziale	spacer	entretoise		

**561-40 / 563-40**

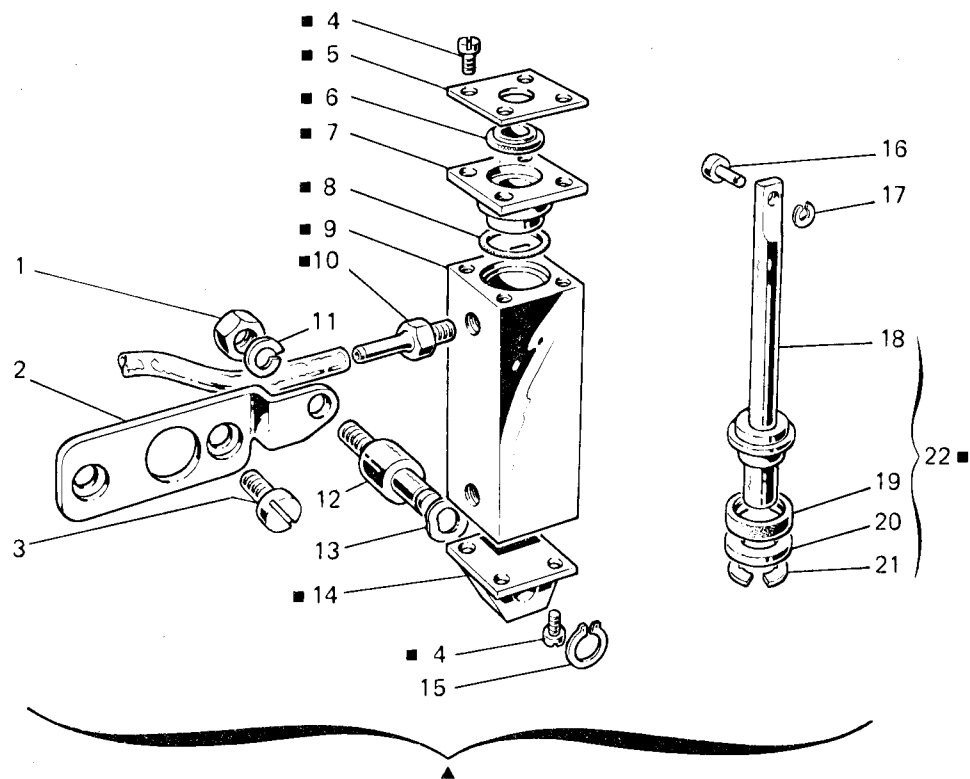




Fig. N. Abb. N.	Part. N. Bestell N. Piece N. Pieza N.	Qt. Anzahl	DESCRIZIONE	DESCRIPTION	DESCRIPTION	BENENNUNG	DESCRIPCION
▲	924381-4-00	1	gruppo pistone (escluso figg. 7-12-25-26)	piston assembly (excluded figs. 7-12-25-26)	groupe piston (exclu figs. 7-12-25-26)		
■	924382-4-00	1	gruppo pistone	piston assembly	groupe piston		
1	746402-2-00	1	dado	nut	écrou		
2	924383-0-00	1	piastra	plate	plaque		
3	742214-2-00	2	vite	screw	vis		
4	741552-0-00	8	vite	screw	vis		
5	926265-0-00	1	coperchietto	cover	couvercle		
6	923828-4-00	1	anello di tenuta	retainer ring	bague d'étanchéité		
7	926266-0-01	1	flangia	flange	flasque		
8	701023-0-00	1	anello di tenuta	retainer ring	bague d'étanchéité		
9	926257-0-00	1	cilindro	cylinder	cylindre		
10	924380-0-00	1	attacco	pipe union	raccord		
11	703007-0-00	1	rondella elastica	spring washer	rondelle élastique		
12	926268-0-00	1	perno	pin	pivot		
13	926329-0-00	1	anello elastico	spring ring	anneau ressort		
14	926264-0-00	1	coperchio posteriore	rear cover	couvercle arrière		
15	700207-0-00	1	anello elastico	spring ring	anneau ressort		
16	203847-0-10	1	perno	pin	pivot		
17	700205-0-00	1	anello elastico	spring ring	anneau ressort		
18	926258-0-00	1	pistone	piston	piston		
19	926309-4-00	1	anello di tenuta	retainer ring	bague d'étanchéité		
20	926267-0-00	1	rondella	washer	rondelle		
21	700209-0-00	1	anello elastico	spring ring	anneau ressort		
22	926259-4-00	1	pistone completo	piston assembly	piston complet		

**538-40 / 561-40 / 563-40**

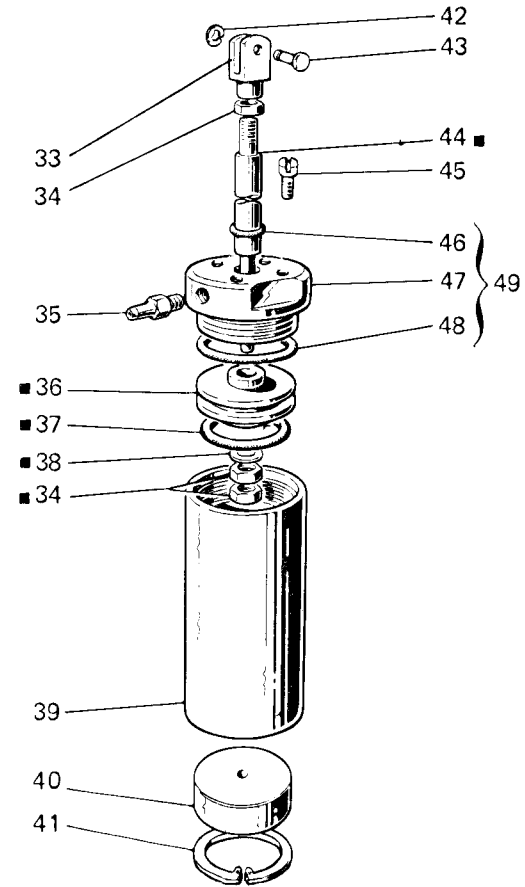
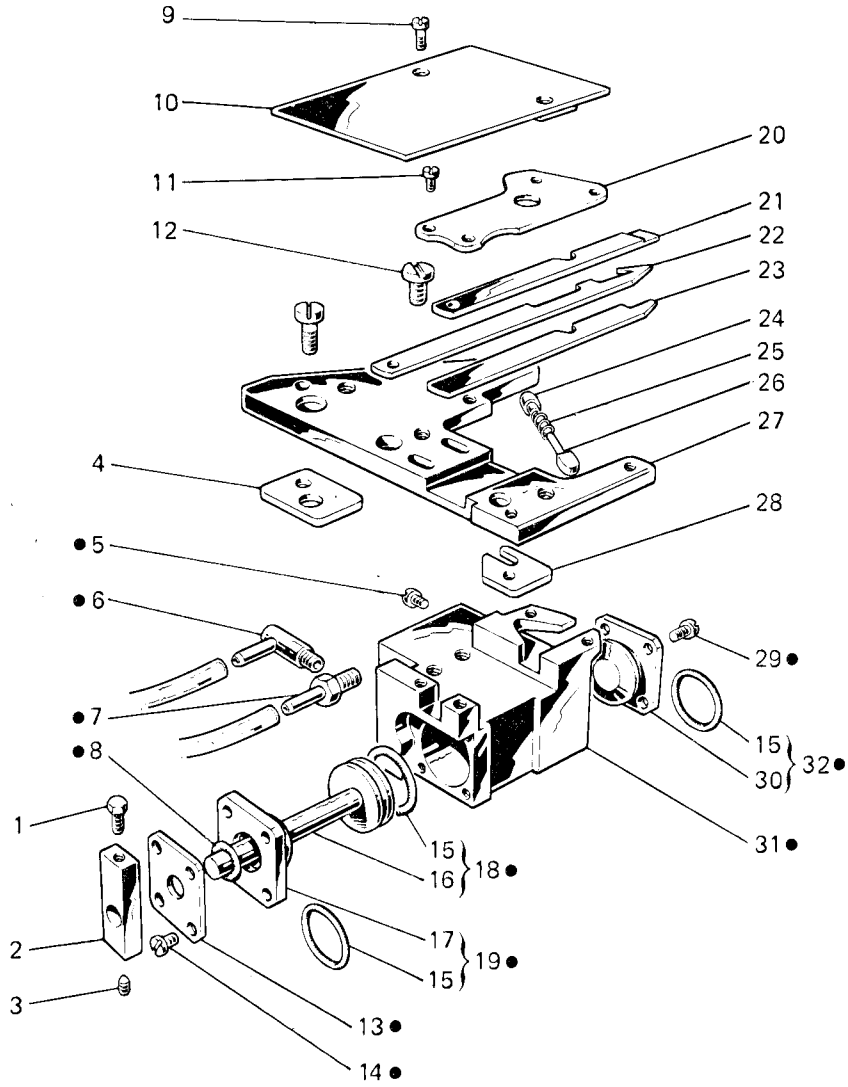
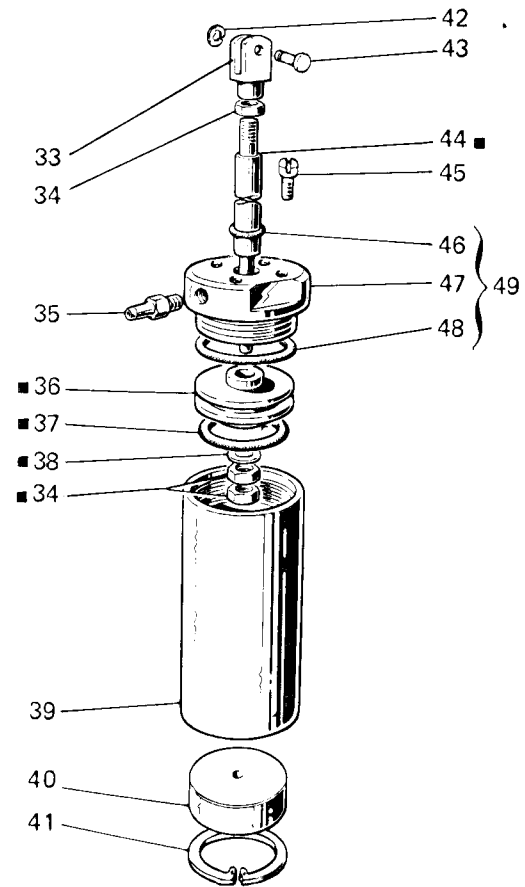
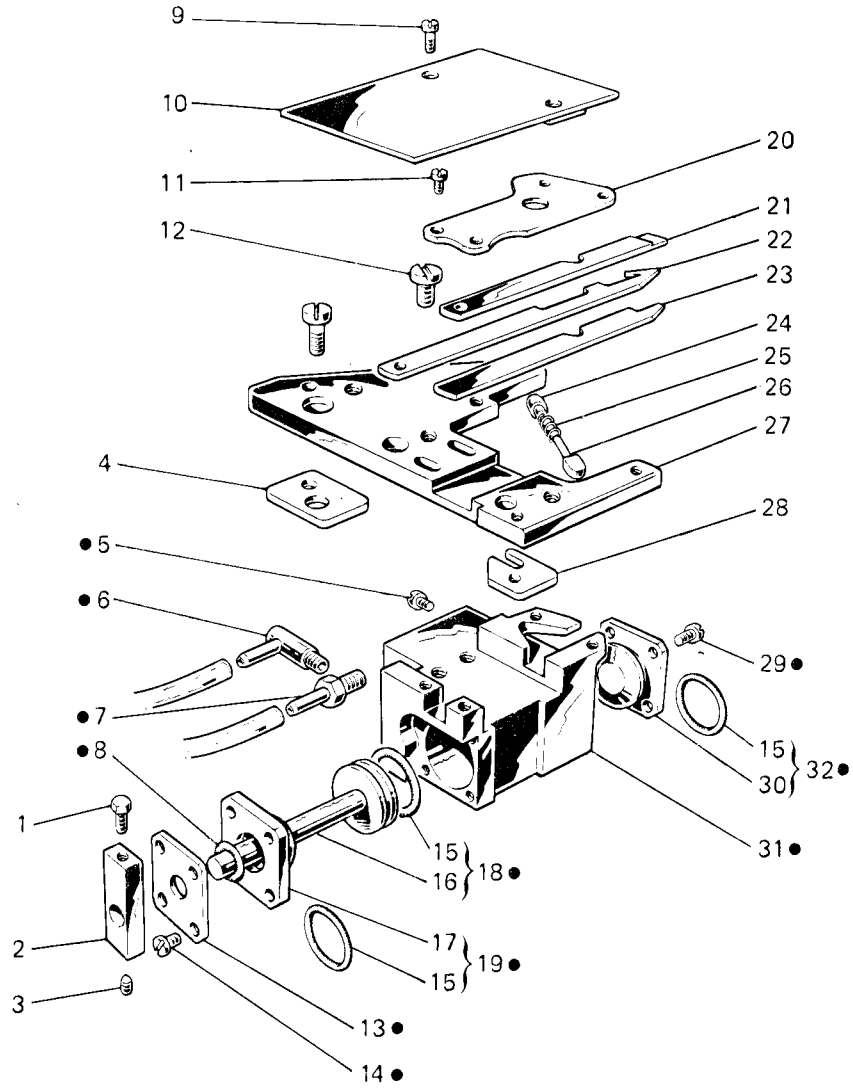


Fig. N. Abb. N.	Part. N. Bestell N. Piece N. Pieza N.	Qt. Anzahl	DESCRIZIONE	DESCRIPTION	DESCRIPTION	BENENNUNG	DESCRIPCION
★	924390-5-01	1	gruppo pistoncino (escluso figg. 9-10)	piston assembly (excluded figs. 9-10)	groupe piston (exclu fig. 9-10)		
●	924391-4-01	1	pistoncino completo	piston assembly	piston complet		
▲	924408-4-00	1	gruppo pistone (escluso figg. 42-43-45)	piston assembly (excluded figs. 42-43-45)	groupe piston (exclu fig. 42-43-45)		
■	924805-4-10	1	pistone completo	piston assembly	piston complet		
1	924673-0-10	1	vite	screw	vis		
2	924668-0-10	1	fascetta	clamp	bride		
3	730011-2-00	1	vite	screw	vis		
5	741405-4-00	1	tappo a vite	plug	bouchon		
6	924392-0-01	1	attacco	pipe union	raccord		
7	924393-0-00	1	attacco	pipe union	raccord		
8	701003-0-00	1	anello di tenuta	retainer ring	bague d'étanchéité		
9	741913-4-00	2	vite	screw	vis		
10	924471-2-00	1	carterino	cover	carter		
11	744530-0-00	4	vite	screw	vis		
12	741956-2-00	2	vite	screw	vis		
13	924663-0-10	1	coperchio	cover	couvercle		
14	741461-2-00	4	vite	screw	vis		
15	701009-0-00	3	anello di tenuta	retainer ring	bague d'étanchéité		
16	924659-0-11	1	pistoncino	piston	piston		
17	924661-0-11	1	flangia	flange	flasque		
18	924660-4-11	1	pistoncino completo	piston assembly	piston complet		
19	924662-4-11	1	flangia completa	flange assembly	flasque complète		
20	924667-0-20	1	piastrina	plate	plaque		
21	944422-0-00	1	coltello superiore	upper knife	couteau supérieur		
22	924670-0-11	1	coltello	knife	couteau		
23	924638-0-00	1	lama inferiore	lower sheet	plaque inférieure		
24	924675-0-10	1	fulcro	fulcrum	pivot		
25	100893-0-09	1	molla	spring	ressort		
26	924674-0-10	1	perno	pin	pivot		
27	924472-2-00	1	piastra	plate	plaque		
29	741431-2-00	4	vite	screw	vis		
30	924664-0-11	1	flangia	flange	flasque		
31	924656-0-11	1	corpo	body	corps		
32	924665-4-11	1	flangia completa	flange assembly	flasque complète		
33	990310-0-10	1	forcella	fork	fourche		
34	746402-2-00	3	dado	nut	écrou		
35	924797-0-10	1	attacco	pipe union	raccord		
36	924804-0-10	1	pistone	piston	piston		
37	701037-0-00	1	anello di tenuta	retainer ring	bague d'étanchéité		
38	704218-2-00	1	rondella	washer	rondelle		
39	924802-0-10	1	cilindro	cylinder	cylindre		
40	924407-0-01	1	tappo inferiore	lower plug	bouchon inférieur		
41	700130-0-00	1	anello elastico	spring ring	anneau ressort		
42	700205-0-00	1	anello elastico	spring ring	anneau ressort		
43	990311-0-10	1	perno	pin	pivot		
44	924808-0-10	1	albero	shaft	arbre		

**538-40 / 561-40 / 563-40**



★

▲

Fig. N. Abb. N.	Part. N. Bestell N. Piece N. Pieza N.	Qt. Anzahl	DESCRIZIONE	DESCRIPTION	DESCRIPTION	BENENNUNG	DESCRIPCION
45	721474-2-00	3	vite	screw	vis		
46	701007-0-00	1	anello di tenuta	retainer ring	bague d'étanchéité		
47	924806-0-10	1	tappo superiore	upper plug	bouchon supérieur		
48	701132-0-00	1	anello di tenuta	retainer ring	bague d'étanchéité		
49	924807-4-10	1	tappo superiore compl.	upper plug assembly	bouchon supérieur compl.		
			SOLO A RICHIESTA	ONLY ON REQUEST	SEULEMENT SUR DEMANDE		
23	924669-0-10	1	lama inferiore	lower sheet	plaque inférieur		
			SOLO PER TESTE	HONLY FOR HEADS	SEULEMENT POUR TETES		
			171-10-3MK-01	171-16-3MK-01			
4	924476-0-00	1	piastrina	plate	plaque		
28	924135-0-00	1	piastrina	plate	plaque		

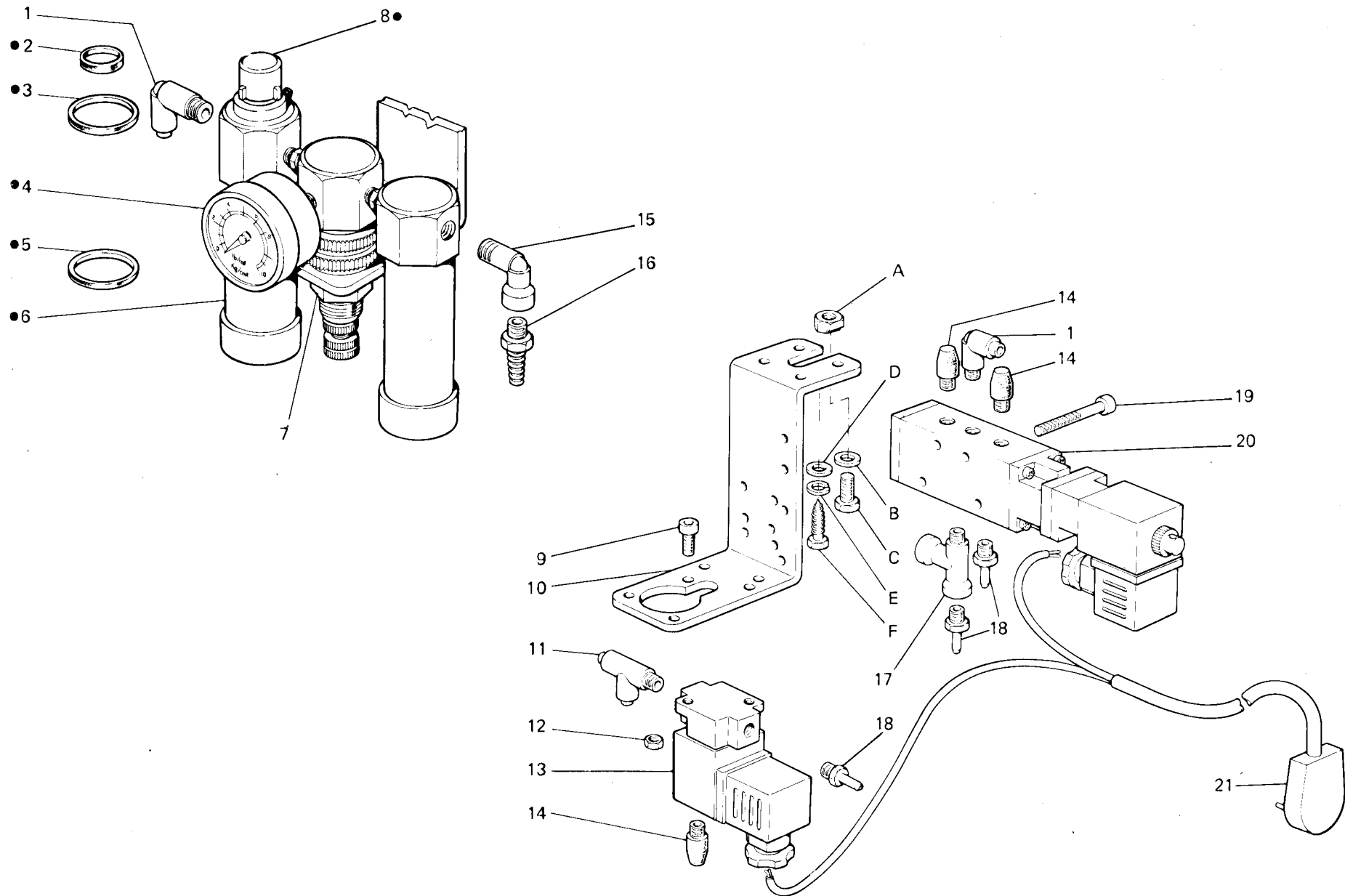
**538-40 / 561-40 / 563-40**

Fig. N. Abb. N.	Part. N. Bestell N. Piece N. Pieza N.	Qt. Anzahl	DESCRIZIONE	DESCRIPTION	DESCRIPTION	BENENNUNG	DESCRIPCION
—	925233-4-00	1	gruppo F.R.L.	F.R.L. assembly	groupe F.R.L.		
●	925772-4-10	1	F.R.L. completo	F.R.L. assembly	F.R.L. complet		
1	941511-4-00	2	raccordo	pipe connection	raccord		
2	924994-0-00	1	guarnizione	gasket	garniture		
3	924991-0-00	2	guarnizione	gasket	garniture		
4	922846-4-00	1	manometro	manometer	manomètre		
5	924990-0-00	2	guarnizione	gasket	garniture		
6	924992-0-00	2	tazza	contéiner	tasse		
7	924814-0-00	1	dado	nut	écrou		
8	924993-4-00	1	cappello	cap	capuchon		
9	722421-2-00	2	vite	screw	vis		
10	925557-0-00	1	supporto	support	support		
11	941524-4-00	1	raccordo	pipe connection	raccord		
12	733505-2-00	2	dado	nut	écrou		
13	925234-4-10	1	elettrovalvola	electrovalve	soupape électrique		
14	924851-0-10	3	silenziatore	silencer	silencieux		
15	923803-0-00	1	raccordo	pipe connection	raccord		
16	923804-0-00	1	attacco	attachment	raccord		
17	926305-0-00	1	raccordo	pipe connection	raccord		
18	924870-0-10	3	attacco	attachment	raccord		
19	722511-2-00	2	vite	screw	vis		
20	929299-4-10	1	elettrovalvola	electrovalve	soupape électrique		
21	925242-0-00	1	cavo con spina	cable with pin	cable avec goupille		
			SOLO PER BANC.REGOLABILE	ONLY FOR ADJUST.STAND	SEULEMENT POUR BATI REGLABLE		
A	902272-0-00	1	dado	nut	écrou		
B	704011-4-00	1	rondella	washer	rondelle		
C	720485-2-00	1	vite	screw	vis		
			SOLO PER BANC. A COLONNA	ONLY FOR COLUMN STAND	SEULEMENT POUR BATI A COLONNE		
D	704013-2-00	1	rondella	washer	rondelle		
E	703010-0-00	1	rondella elastica	sping washer	rondelle élastique		
F	731643-0-00	1	vite da legno	screw	vis		

**538-40 / 561-40 / 563-40**

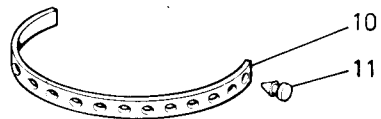
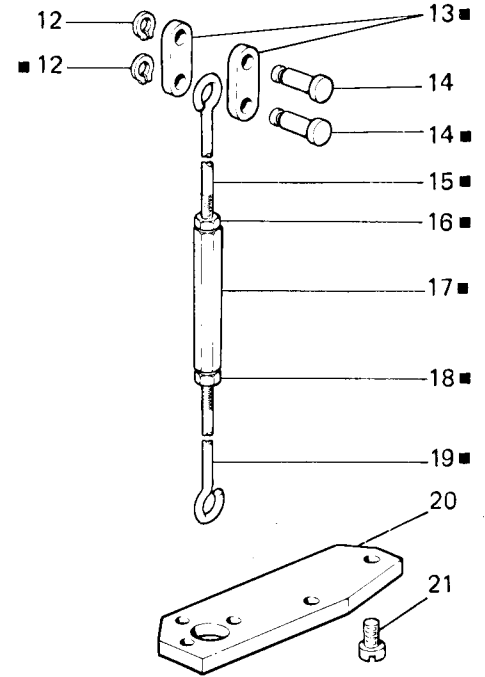
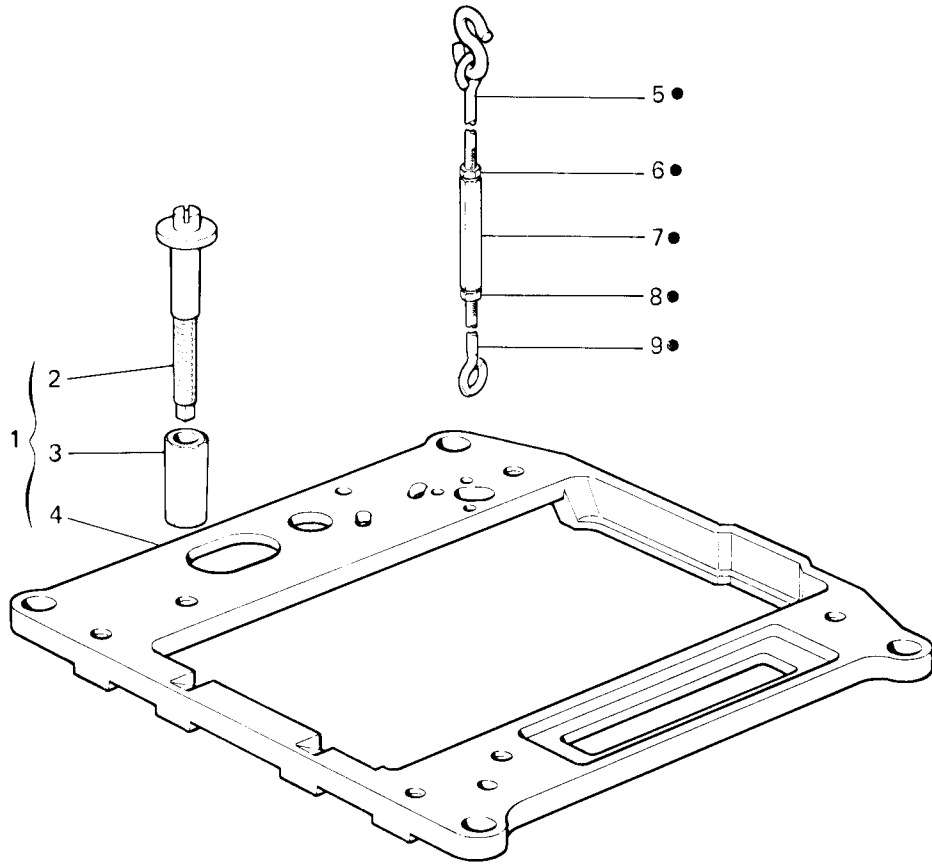




Fig. N. Abb. N.	Part. N. Bestell N. Piece N. Pieza N.	Qt. Anzahl	DESCRIZIONE	DESCRIPTION	DESCRIPTION	BENENNUNG	DESCRIPCION
			SOLO PER BANCALE REG.	ONLY FOR AD ADJUST. STAND	SEULEMENT POUR BATI REGLABLE		
●	901244-4-00	1	tirante completo	tie-rod assembly	tirant complet		
1	901228-4-00	1	supporto completo	support assembly	support complet		
2	901223-0-00	4	perno	pin	pivot		
3	901224-0-00	4	colonnina	column	colonne		
4	901242-0-00	1	supporto	support	support		
5	901217-2-00	1	tirante superiore	upper tie-rod	tirant sup.		
6	733505-2-00	1	dado	nut	écrou		
7	910190-0-10	1	bussola	bush	buque		
8	746601-2-00	1	dado	nut	écrou		
9	901243-0-00	1	tirante inferiore	lower tie-rod	tirant inférieure		
10	990441-0-10	5	cinturino	strap	bride		
11	990442-0-10	5	bottoncino	button	bouton		
			SOLO PER BANC. A COLONNA	ONLY FOR COLUMN STAND	SEULEMENT POUR BATI A COLONNE		
■	910214-4-11	1	tirante completo	tie-rod assembly	tirant complet		
10	990441-0-10	3	cinturino	strap	bride		
11	990442-0-10	3	bottoncino	button	bouton		
12	700205-0-00	2	anello elastico	spring ring	anneau ressort		
13	990765-0-00	2	piastrina	shut	plaquette		
14	203211-0-10	2	perno	pin	pivot		
15	910187-0-11	1	tirante superiore	upper tie-rod	tirant sup.		
16	733505-2-00	1	dado	nut	écrou		
17	910190-0-10	1	bussola	bush	bague		
18	746601-2-00	1	dado	nut	écrou		
19	910213-0-10	1	tirante inferiore	lower tie-rod	tirant inférieure		
20	990440-0-10	1	piastrina	plate	plaque		
21	721484-2-00	2	vite	screw	vis		

**538-40 / 561-40 / 563-40**

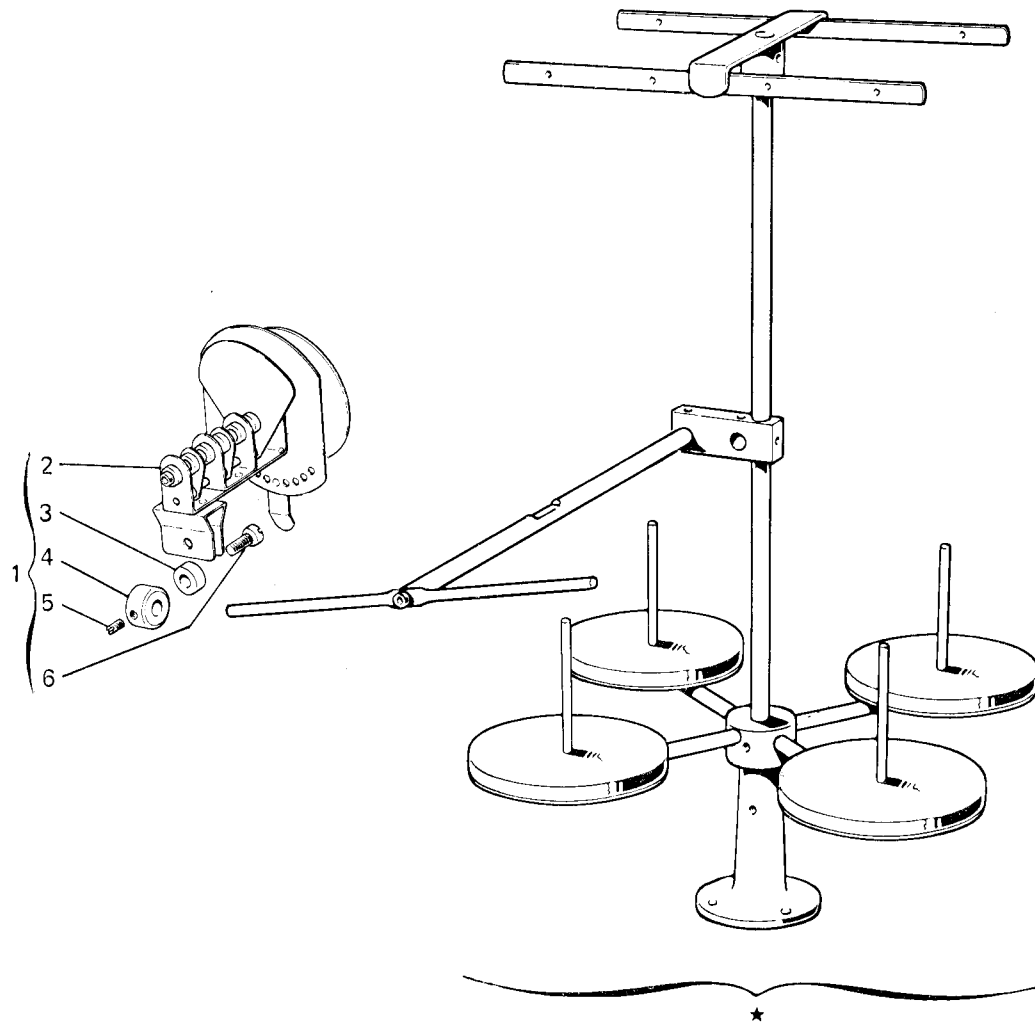


Fig. N. Abb. N.	Part. N. Bestell N. Piece N. Pieza N.	Qt. Anzahl	DESCRIZIONE	DESCRIPTION	DESCRIPTION	BENENNUNG	DESCRIPCION
★	991155-5-01	1	porta bobine completo (3-4 fili)	bobbin carrier assembly	porte-bobine complet		
1	991158-4-00	3	frenaggio completo	breakage assembly	freinage complet		
2	990445-0-10	3	frenaggio	breakage	freinage		
3	304257-0-10	3	distanziale	spacer	entretoise		
4	991159-0-00	3	anello	ring	anneau		
5	727014-2-00	3	vite	screw	vis		
6	741956-2-00	3	vite	screw	vis		
			VARIANTE PER TESTE	VARIATION FOR HEAD	VARIANTE POUR TETE		
				171-10-3MK-01 / 171-16-3MK-01			
1	991158-4-00	4	frenaggio completo	breakage assembly	freinage complet		
2	990445-0-10	4	frenaggio	breakage	freinage		
3	304257-0-10	4	distanziale	spacer	entretoise		
4	991159-0-00	4	anello	ring	anneau		
5	727014-2-00	4	vite	screw	vis		
6	741956-2-00	4	vite	screw	vis		

## TAV.17

Fig. N. Abb. N.	Part. N. Bestell N. Piece N. Pieza N.	Ct. Anzahl	DESCRIZIONE	DESCRIPTION	DESCRIPTION	BENENNUNG	DESCRIPCION
1	924539-0-01	1	SOLO PER TESTE 171-10-3MK-01 griffa differenziale passo 1,5 mm	ONLY FOR HEADS 171-16-3MK-01 differential feed dog dist. 1.5 mm	SEULEMENT POUR TETES 171-16-3MK-01 griffe différentielle dist. 1,5 mm.		
2	924551-0-11	1	SOLO A RICHIESTA PER TESTA griffa differenziale passo 1,5 mm	ONLY ON REQUEST FOR HEAD 171-16-3MK-01 differential feed dog dist. 1.5 mm	SEULEMENT SUR DEMANDE POUR TETE griffe différentielle dist. 1,5 mm		
3	311264-0-00	1	griffa principale passo 1,5 mm	main feed dog dist. 1.5 mm	griffe principale dist. 1,5 mm		
4	311368-0-00	1	placca ago calibro 6	needle plate	plaque à aiguille		