

264-12-2MU-01

EDIZIONE - EDITION 2/82

**n. 260**

Il presente Catalogo Pezzi di Ricambio è costituito da due parti: la prima, definita come "Catalogo base", comprende i particolari montati sulla testa più significativa (la prima dell'elenco in copertina); la seconda comprende tutti i particolari delle altre teste basi o derivate, che differiscono da quella del Catalogo base.

Le Teste basi sono elencate in copertina con un carattere più grande rispetto a quello delle derivate.

Nella consultazione del Catalogo tenere presente che:

1. Tutti i particolari non fornibili sciolti non vengono richiamati singolarmente, ma soltanto illustrati nel gruppo d'appartenenza.
2. I riferimenti delle figure dei particolari che compongono il gruppo sono di norma raggruppati in una parentesi. In alcuni casi però, dove non è possibile il raggruppamento, i numeri che nelle tavole illustrative richiamano i singoli pezzi sono affiancati dallo stesso segno particolare, con cui è indicato l'intero gruppo.
3. Sulle tavole relative alle altre teste sono elencati tutti i particolari diversi o non montati sulla testa del Catalogo Base. Dette tavole portano in alto a destra il simbolo della testa cui si riferiscono (con indicato fra parentesi - nel caso di derivata - il simbolo della testa da cui deriva).  
I disegni di questo gruppo di tavole illustrano soltanto i pezzi nuovi o sostanzialmente diversi rispetto a quelli montati sulla testa più significativa del Catalogo.  
I particolari richiamati come simbolo, ma non illustrati, conservano lo stesso numero di figura dei corrispondenti raffigurati sul Catalogo base.  
I particolari comuni a tutte le teste comprese nel Catalogo, vengono richiamati soltanto nel primo gruppo di tavole.  
I particolari definiti come "pezzi annullati" si intendono quelli non montati sulla testa a cui la tavola si riferisce. Nel caso di un gruppo annullato, viene indicato soltanto il simbolo del gruppo, ma devono intendersi annullati anche tutti i particolari componenti il gruppo stesso.  
Per ogni testa viene sempre riportata interamente la tavola relativa agli organi di cucitura.

Per facilitare la ricerca viene riportato l'indice numerico di tutti i particolari illustrati sul Catalogo base, con la relativa tavola in cui gli stessi sono richiamati.

#### AGHI

Gli aghi sono contraddistinti dal sistema e dalla finezza, la quale indica il diametro medio espresso in centesimi di millimetro.

Il sistema dell'ago e la finezza sono marcati oltre che sulla busta, anche sull'ago stesso.

Nelle ordinazioni precisare, oltre il simbolo, il sistema e la finezza degli aghi desiderati. In caso di dubbio, allegare, un ago campione o una bustina vuota.

#### AVVERTENZA

Nella richiesta di parti di ricambio citare sempre il relativo numero di matricola della macchina, il simbolo del particolare e la denominazione ufficiale usata sul catalogo.

This spare parts catalogue is made up of two parts: in the first one, called "basic catalogue", all the details of most representative head are listed (the first head listed on the cover); the second one includes the details of the other main heads or derived ones, which are different from that of the basic catalogue.

The main heads are listed on the cover in bigger lettering to distinguish them from the derived heads.

When you consult the catalogue will you please note that:

1. all parts which cannot be supplied by themselves are not indicated alone, but shown together with the group to which they belong;
2. the references of the pictures of the parts making up the group are usually put in brackets.  
In some cases, however, when their grouping is not possible, the numbers of the various parts in the tables are marked with the same particular sign with which the whole group is indicated.

3. In the tables of the other heads there are listed all the parts not fitted on the head in the basic catalogue.

These tables are marked at the top right-hand corner with the symbol of the head which the table refers to.

The drawings in this group of tables show only the parts which are new or basically different from those fitted on the most representative head in the catalogue.

The parts which are represented only by the symbol but not illustrated keep the same figure number as the corresponding parts shown in the basic catalogue.

The parts which are common to all the heads in the catalogue are listed only in the first group of tables.

Parts marked "annulled part" are those not fitted on the head which the table refers to.

When an assembly has been annulled only the assembly symbol is specified, but all the parts forming the assembly must also be considered annulled.

For each head the table for sewing parts is always repeated completely.

To make it easier to locate the parts, the reference numbers of all of those shown in the basic catalogue are listed together with the number of the table in which they are to be found.

#### NEEDLES

The needles are marked with system and size; the size indicates the average diameter in hundredths of a millimeter.

The system and size of the needle are shown on the packet as well as on the needle itself.

When ordering please state symbol, system and size. If you have doubts, enclose a sample needle or an empty packet with your order.

#### ATTENTION

When ordering spare parts always state the serial number of the machine, the symbol of the part in question and the description given in the catalogue.

Ce catalogue "pièces détachées" est formé de deux parties: la première appelée "catalogue base" comprend toutes les pièces montées sur la tête la plus significative (celle en tête de la liste de couverture), la seconde comprend toutes les pièces montées sur les autres têtes de base ou dérivées qui sont différentes de celle du "catalogue base".

Les têtes de base sont énumérées sur la couverture, en caractères plus grands que les têtes dérivées.

Lorsque l'on consulte le catalogue, se souvenir que:

1. Toutes les pièces qui ne sont pas fournies séparément mais qui font partie d'un groupe, ne sont pas indiquées séparément.
2. Les symboles des pièces qui forment un groupe sont regroupés entre parenthèses. Cependant, lorsque ceci n'a pas été possible, les symboles, qui dans les tables d'illustration correspondent aux pièces, sont suivis du même signe particulier qui indique le groupe tout entier.

3. Dans les tables relatives aux autres têtes, nous avons indiqué toutes les pièces différentes de celles de tête du "catalogue base" ou qui ne sont pas montées sur ces dernières. Ces tables portent, en haut à droite, le symbole des têtes auxquelles elles se réfèrent (pour les dérivées, le symbole de la tête de laquelle elles dérivent est indiqué entre parenthèses).

Les dessins de ce groupe de tables représentent seulement les nouvelles pièces ou celles qui sont différentes des pièces montées sur la tête la plus significative du catalogue.

Les pièces indiquées par un symbole, mais qui ne sont pas illustrées, gardent le même numéro de dessin que celles correspondantes, illustrées sur le catalogue base.

Les pièces communes à toutes les têtes du catalogue, sont indiquées seulement dans le premier groupe de tables.

Les pièces définies comme "pièces annulées" sont celles qui ne sont pas montées sur la tête à laquelle se réfère la table. Dans le cas de l'annulation d'un groupe, nous indiquons seulement le symbole du groupe, mais toutes les pièces qui forment ce groupe sont annulées.

Pour chaque tête est toujours indiquée la table se référant aux organes de couture.

Pour faciliter la recherche, le catalogue renferme l'index numérique de toutes les pièces illustrées avec indication de la table dans laquelle elles sont indiquées.

#### AIGUILLES

Les aiguilles se différencient par le système et la grosseur, laquelle indique le diamètre moyen exprimé en centièmes de millimètre.

Le système de l'aiguille et sa grosseur, sont indiqués non seulement sur le sachet mais également sur l'aiguille.

Dans la commande, préciser, en plus du symbole, le système et la grosseur des aiguilles désirées. En cas de doute, joindre une aiguille comme modèle ou un sachet vide.

#### ATTENTION

Dans la commande de pièces détachées, indiquer toujours le numéro de la machine, le symbole de la pièce et la dénomination officielle mentionnée sur le catalogue.



INDICE NUMERICO INDEX

Part. N.	Tav. N.	Part. N.	Tav. N.	Part. N.	Tav. N.	Part. N.	Tav. N.	Part. N.	Tav. N.	Part. N.	Tav. N.	Part. N.	Tav. N.
102041-0-00	11	300310-0-10	2	303539-0-00	7	308047-0-00	8	308178-4-01	5	308326-2-01	8	308853-0-01	1
200324-0-10	2	300351-0-11	8	303664-0-12	16	308052-4-00	12	308179-0-00	14	308327-0-00	8	308855-0-00	5-9
200710-0-10	13	300352-0-10	8	303665-0-13	16	308054-0-01	12	308180-2-00	15	308330-3-00	8	308858-0-00	1
200714-0-10	13	300377-0-10	4	304612-0-11	4	308055-2-00	12	308184-0-00	15	308331-4-00	14	308859-2-00	1
201143-0-10	4	300391-0-10	2	304616-0-11	4	308056-0-01	12	308185-0-00	15	308334-0-01	8	308957-0-00	14
202128-0-10	11	300469-2-11	7	304640-0-10	4	308057-0-00	12	308190-0-00	4	308364-4-01	6	308967-2-00	4
202129-0-10	11	300482-0-10	7-8	304662-0-10	3	308058-0-00	12	308201-0-01	2	308379-0-00	14	308971-3-00	4
202130-0-11	11	300483-0-10	2-3-16	304684-0-10	4	308059-0-00	12	308203-0-01	2	308386-2-01	6	308996-0-01	13
202134-0-11	11	301519-2-11	4	304763-0-10	13	308060-4-00	12	308206-0-00	14	308389-0-00	5	309084-0-00	3
202142-0-10	11	301531-0-00	16	304767-2-10	12	308061-0-01	12	308207-0-00	15	308406-0-00	1	309088-0-01	3
202165-0-10	16	301586-0-10	4	305194-0-00	8	308084-2-00	5	308208-0-00	14	308412-2-02	12	309089-2-00	3
202229-0-10	13	301608-0-00	4	305489-0-10	16	308086-0-11	1	308209-0-00	14	308451-0-10	9	309126-3-00	3
202239-0-10	3	302052-2-21	7	305666-0-00	15	308090-0-01	5	308210-0-00	14	308452-2-00	9	309139-4-00	3
202397-0-10	7	302059-0-10	12	307068-0-00	10	308094-0-00	1	308211-0-00	15	308458-3-00	8	309197-2-00	3
202398-0-10	1	302060-0-11	12	307136-0-01	16	308098-0-00	12	308213-0-00	14	308459-4-00	8	309332-0-00	3
202468-0-10	4	302136-0-12	2	307138-0-00	16	308100-0-01	3	308214-0-00	15	308462-0-00	3	309351-0-00	3
202474-0-10	7	302149-0-11	2	307394-2-11	16	308102-0-00	3	308215-0-00	1	308495-2-01	13	309371-0-00	3
202486-0-10	4	302168-2-10	2	307395-4-02	16	308103-4-10	3	308218-0-00	1	308501-0-01	13	309372-0-00	3
202556-0-00	13	302172-0-10	2	307396-0-11	16	308104-0-00	15	308221-0-00	9	308502-0-00	13	309560-0-00	4
202558-2-00	13	302204-0-10	2	307704-0-00	4	308105-4-03	15	308226-0-02	14	308503-0-01	13	309830-2-00	9
204786-0-10	4	302232-0-10	13	307990-0-00	15	308107-0-00	2	308253-3-00	5	308504-0-00	13	309831-2-00	9
204938-0-10	10	302234-0-10	12	307991-0-00	15	308110-3-02	15	308263-4-00	7	308505-0-00	13	309838-2-01	4
205395-0-11	11	302238-0-10	13	308002-0-00	14	308111-0-00	15	308272-0-00	7	308506-0-00	13	309839-2-01	4
206545-0-00	14	302272-0-10	5	308006-4-00	9	308113-0-00	14	308273-0-00	7	308507-0-00	13	310350-4-00	5
206555-0-01	15	302276-0-10	7	308007-0-00	12	308114-2-02	15	308278-0-01	6	308512-0-00	13	310500-4-00	15
206557-0-00	15	302289-0-10	8	308009-0-00	1	308119-0-00	4	308281-0-00	6	308518-4-00	13	310554-2-00	4
206559-0-01	14	302292-0-10	9	308012-2-10	5	308123-0-00	15	308283-2-10	4	308521-4-00	13	310555-0-00	4
206560-0-10	14	302338-0-10	9	308013-4-02	5	308125-0-01	14	308285-2-02	4	308527-4-00	13	310556-2-00	4
206564-0-00	14	302344-0-10	12	308031-0-00	1	308127-0-00	5	308286-4-00	4	308551-0-00	2	310557-2-10	4
206665-2-00	14	302352-0-10	9	308032-0-00	1	308128-0-00	3	308287-0-00	4	308553-2-00	2	310558-2-01	4
206669-2-02	15	302353-0-10	3	308036-2-00	9	308129-0-00	3	308289-4-11	4	308556-0-00	2	310559-0-00	4
206708-0-00	11	302354-0-20	3	308037-0-00	9	308137-0-00	2	308292-4-00	7	308558-0-00	2	310560-0-00	4
206767-0-00	11	302355-0-10	3	308038-0-10	9	308138-0-12	1	308293-0-02	1	308576-2-20	14	310561-2-00	15
206768-0-00	11	302356-0-10	1	308039-0-01	9	308140-0-00	7	308294-0-10	4	308588-4-10	14	310568-0-01	4
206769-0-10	11	302393-0-00	8	308040-2-00	15	308148-0-00	12	308296-0-00	1	308646-3-20	1	310569-0-00	4
206841-0-01	2	303045-0-10	2	308041-0-00	9	308149-0-01	5	308297-0-00	1	308714-3-01	6	310573-2-00	4
207387-0-00	11	303458-0-12	6	308042-0-00	9	308159-2-01	5	308298-0-00	1	308774-2-00	6	310574-0-11	4
207388-0-00	11	303494-0-10	4	308043-0-00	15	308161-0-00	5	308310-0-00	5	308780-2-00	6	310575-0-01	4
207653-0-01	11	303501-0-10	1	308044-0-00	8	308162-0-00	5	308320-4-00	13	308802-0-00	5	310577-2-00	4
300006-0-12	3	303503-0-10	7	308045-0-01	8	308166-0-00	5	308321-0-00	13	308851-2-01	9	310579-2-01	4
300218-0-10	13	303538-0-00	7	308046-2-01	8	308174-3-01	5	308325-3-00	8	308852-0-01	1	310580-4-01	4

INDICE NUMERICO INDEX

Part. N.	Tav. N.	Part. N.	Tav. N.	Part. N.	Tav. N.	Part. N.	Tav. N.	Part. N.	Tav. N.	Part. N.	Tav. N.	Part. N.	Tav. N.
310583-0-00	4	312371-2-00	11	701004-0-00	15	705029-0-00	4	727834-2-00	13	741724-2-00	11	780200-0-40	16
310585-0-00	4	312372-0-00	11	701009-0-00	8	705034-0-00	11	728232-0-00	4	741747-0-00	11	788020-0-01	3
310589-2-00	4	312373-0-00	11	701032-0-00	15	705201-0-00	2	729012-2-00	2	741936-2-00	11	790242-0-00	15
310593-0-00	4	312376-0-00	11	701051-0-00	14	705734-0-00	7	729013-2-00	4-9	741937-0-00	16	790315-0-00	15
310594-0-00	4	312377-2-00	11	701134-0-00	14	705834-0-00	8	729022-2-00	10	741956-2-00	11	790325-0-00	15
310595-0-00	4	312384-4-00	11	701405-0-00	13	705970-0-00	3	729032-2-00	1	741984-2-00	11	790342-0-00	15
310596-2-00	4	312390-0-00	11	702403-0-00	7	705977-0-00	14	729034-2-00	13	742222-2-00	5	900201-0-10	19
310597-4-00	4	312391-0-00	11	703003-0-00	14	706454-0-00	1	729044-2-00	5	742282-2-00	3	900203-0-10	19-20
310598-4-00	4	312392-2-01	9	703005-0-00	4-9	706455-0-00	11	729434-2-00	8	742311-2-00	9	900204-0-10	20
310599-4-00	4	312393-4-00	9	703802-0-00	16	707240-0-00	12	729884-2-00	13	742423-0-00	7	900694-0-11	19
310605-0-00	10	312394-0-00	3	703810-0-00	7	707241-0-00	13	730033-2-00	7-9	742457-2-00	11	900918-0-00	19-20
310606-4-00	2	312395-2-00	16	704009-4-00	19-20	707556-0-00	3	730054-2-00	5	742813-0-00	4	900920-0-00	19-20
310610-2-00	10	312399-0-00	3	704103-2-00	11	720411-2-00	3	731107-0-00	17	743134-2-00	16	900925-4-01	19-20
310611-4-00	10	312403-4-00	3	704104-2-00	2-16	720464-4-00	19-20	733008-2-00	19-20	743541-2-00	19-20	900926-0-00	19-20
310612-0-00	10	312404-2-00	3	704206-2-00	11	720505-4-00	19-20	733505-2-00	4	744040-2-00	8	900927-0-00	19-20
310614-0-00	10	312405-0-00	11	704210-4-00	2-9	720545-4-00	19-20	733507-0-00	15	744332-2-00	12	900928-0-00	19-20
310615-2-11	4	312406-0-00	3	704218-2-00	2-4	720546-0-00	20	733508-4-00	19-20	744334-2-00	11	900929-0-01	19-20
310630-4-00	4	312408-2-00	3	704226-2-00	4-7	721424-2-00	15	733510-4-00	19-20	744636-2-00	3-11	900931-0-00	19-20
311051-0-00	4	312422-0-00	16	704236-2-00	12	721444-2-00	1-2	733813-0-00	19-20	744676-2-00	8-13	901101-0-00	19-20
311098-0-00	2	312423-0-00	16	704240-2-00	13	721475-2-00	3	740034-2-00	13	744730-0-00	3	901102-0-00	19-20
311253-0-00	4	312424-0-00	16	704302-4-00	2	721484-2-00	14	740210-2-00	2-16	745001-0-00	9	901251-2-00	20
311377-0-01	10	312425-3-00	16	704306-2-00	3-4	721486-2-00	17	740220-2-00	2	745126-2-00	13	901253-0-00	20
311378-0-00	10	312429-0-00	16	704309-4-00	8	721494-2-00	12	740226-0-00	7	745136-2-00	4	901397-0-00	16
311379-2-01	13	312432-2-00	9	704310-2-00	19-20	721514-0-00	15	740240-0-00	14	745800-2-00	4-11-16	930000-4-12	17
311381-0-00	10	312433-0-00	9	704316-2-00	19-20	722063-2-00	14	740444-2-00	12	745810-2-00	9	930004-2-21	17
311395-0-00	14	312434-4-00	9	704345-2-00	19-20	722084-2-00	1	740632-2-00	12-13	745812-2-00	4-5	930006-2-21	17
311408-0-00	17	312435-2-00	4	704346-2-00	19-20	722411-2-00	4-14	741056-0-00	5	745815-2-00	4-5-7-8	930096-0-10	17
312352-2-00	11	312441-2-00	4	704347-0-00	4	722432-2-00	10	741082-2-00	15	745827-2-00	6-12	930105-0-10	17
312353-0-00	11	312442-4-00	4	704406-0-00	4	722441-2-00	11	741088-2-00	3	746020-2-00	4	942722-0-00	16
312354-0-00	11	312443-5-00	4	704406-2-00	11	722453-2-00	14	741092-0-00	15	746204-0-00	13	990069-0-00	18
312355-0-00	11	312444-0-00	16	704409-0-00	11	722471-2-00	11	741413-2-00	2-16	746208-2-00	11	990175-0-10	18
312356-2-00	11	312445-4-00	16	704505-2-00	16	722905-2-00	19	741433-2-00	2-9	746406-2-00	4	990176-0-10	18
312357-0-00	11	312446-4-00	16	704802-0-00	4	722907-2-00	20	741445-0-00	4	746407-2-00	4	990179-4-11	19-20
312358-4-00	11	312447-4-00	16	704813-0-00	15	722920-2-00	20	741445-2-00	11	746408-2-00	5-9-10	990181-0-10	18
312360-2-00	11	312448-4-00	16	704814-0-00	6	723266-2-00	17	741612-0-00	2	746409-2-00	19-20	990182-0-10	18
312361-0-00	11	312811-3-00	7	704819-0-00	4	724420-2-00	2	741634-2-00	16	746612-2-00	6	990188-0-10	18
312362-2-00	6	313375-0-01	2	704846-0-00	4-7	724441-0-00	6	741642-2-00	2	766000-6-90	9	990193-0-00	18
312363-0-00	11	700004-0-00	8	704849-0-00	8	724442-2-00	11	741658-2-00	3-16	778208-0-00	4	990317-0-10	19
312365-4-00	6	700205-0-00	12	704869-0-00	5-9	724472-2-00	11	741675-2-00	8-10	778238-0-00	4	990474-0-11	18
312366-2-00	11	700208-0-00	19-20	705008-0-00	4	727077-0-00	11	741682-0-00	2	778427-0-00	11	990578-0-13	18
312368-0-00	11	700596-0-00	5	705013-0-00	5-9	727215-0-00	4	741722-2-00	4	778827-0-00	7	990587-0-10	18



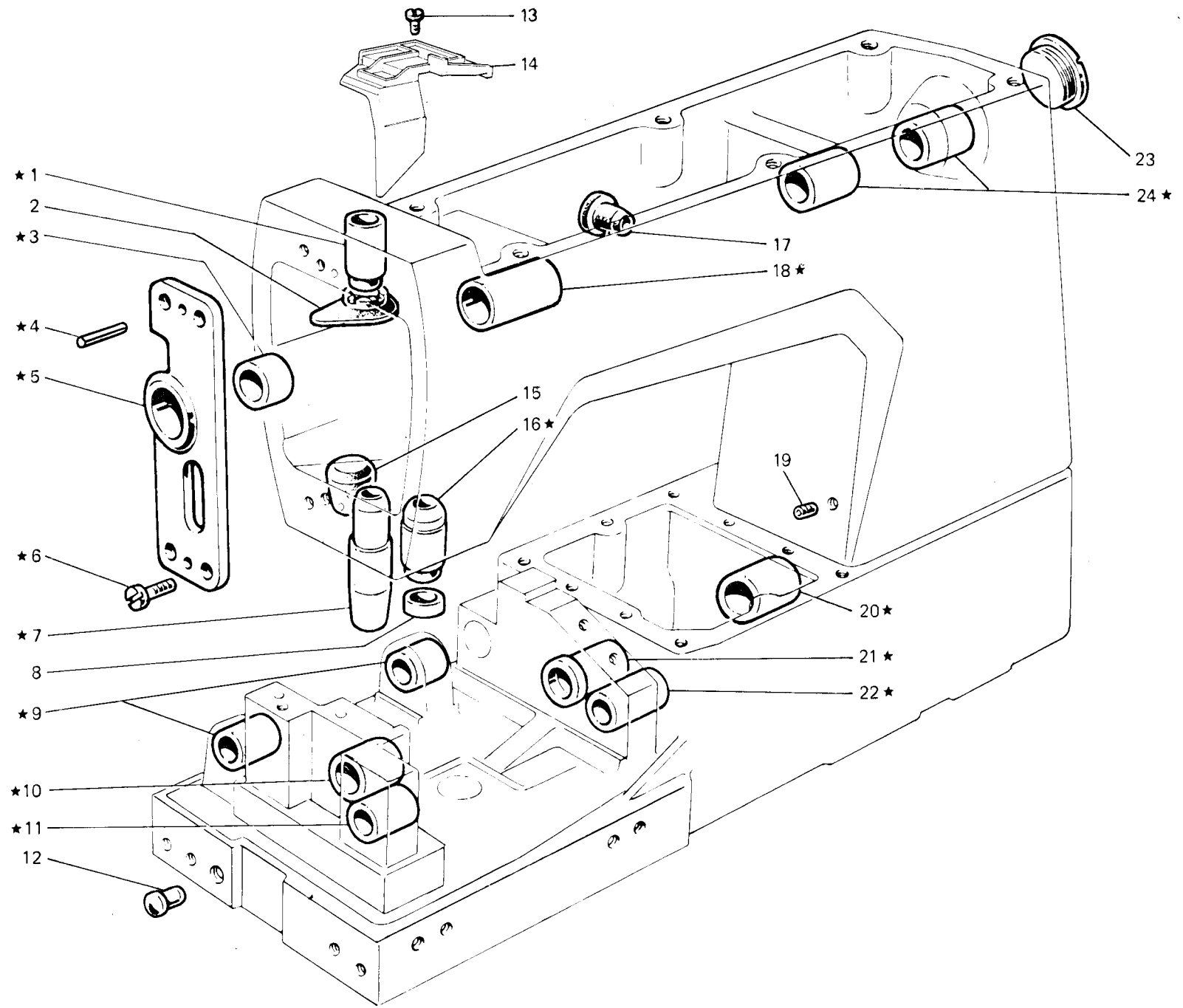



Fig. N. Abb. N.	Part. N. Piecce N. Bestell N. Pieza N.	Qt. Anzahl	DESCRIZIONE	DESCRIPTION	DESCRIPTION	BENENNUNG	DESCRIPTION
★	308646-3-00	1	base e braccio con bussola	base and arm with bushes			
1	308032-0-00	1	bussola	bush	base et bras avec bagues		
2	308215-0-00	1	protezione olio	oil protection	bage		
3	308858-0-00	1	bussola	bush	protection huile		
4	706454-0-00	2	spina	pin	bage		
5	308859-2-00	1	supporto con bussola	support with bush	goupille		
6	722084-2-00	4	vite	screw	support avec bague		
7	308406-0-00	1	bussola	bush	vis		
8	308218-0-00	1	scodellino inferiore	lower cup	bage		
9	308296-0-00	2	bussola	bush	cuvette inférieure		
10	308293-0-02	1	bussola	bush	bage		
11	308297-0-00	1	bussola	bush	bage		
12	202398-0-10	1	tappo	plug	bage		
13	721444-2-00	1	vite	screw	bouchon		
14	308138-0-12	1	carter paraolio	oil retainer	vis		
15	308094-0-00	1	tappo foro bussola	plug	carter protection huile		
16	308031-0-00	1	bussola	bush	bouchon		
17	303501-0-10	1	tappo per foro tendifilo	plug	bage		
18	308852-0-01	1	bussola	bush	bouchon		
19	729032-2-00	1	vite	screw	bage		
20	308086-0-11	1	bussola	bush	vis		
21	308009-0-00	1	bussola	bush	bage		
22	308298-0-00	1	bussola	bush	bage		
23	302356-0-10	1	tappo	plug	bage		
24	308853-0-01	2	bussola	bush	bouchon		
					bage		

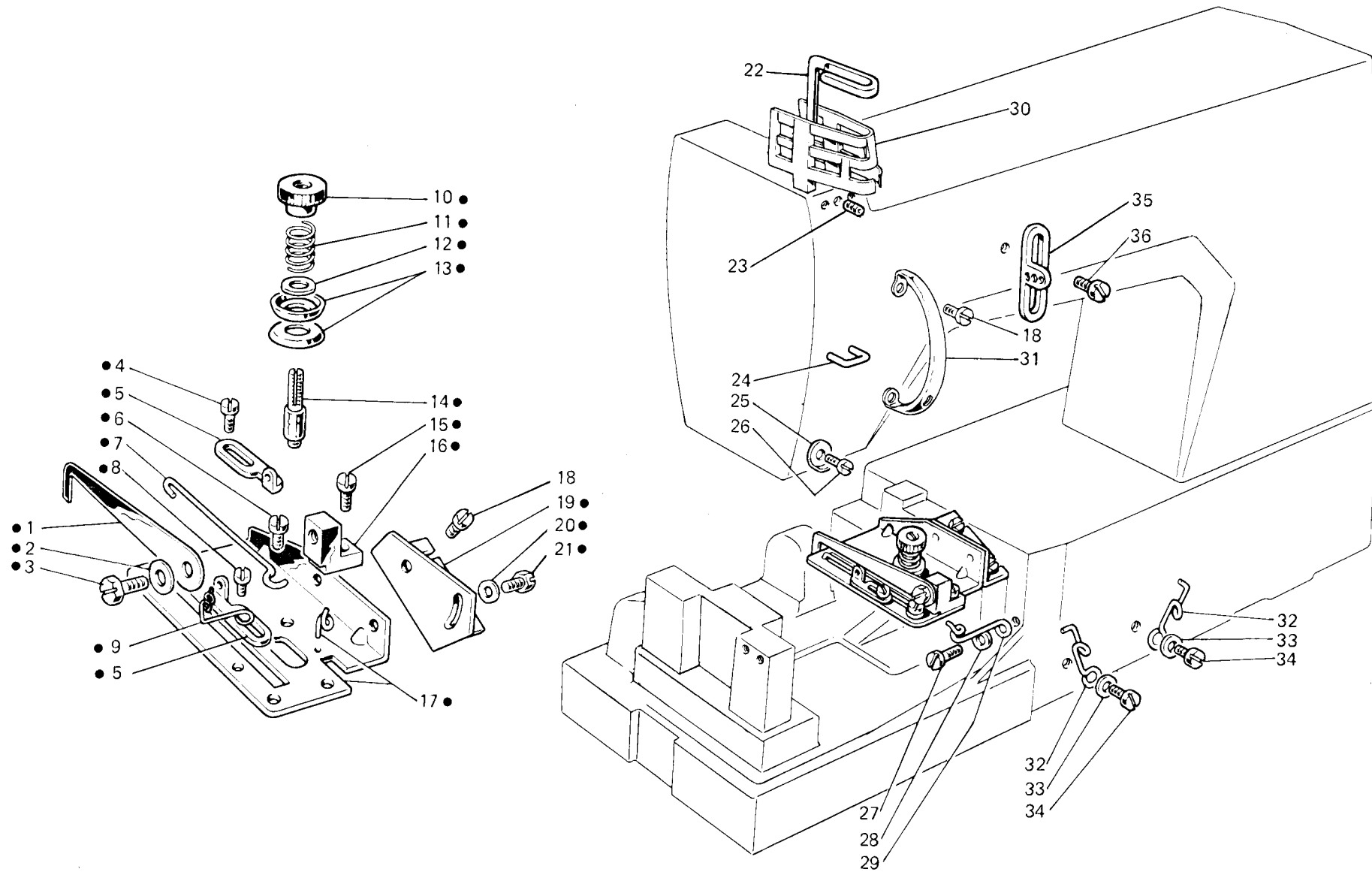

Fig. N. Abb. N.	Part. N. Pezze N. Bestell N. Pieza N.	Qt. Anzahl	DESCRIZIONE	DESCRIPTION	DESCRIPTION	BENENNUNG	DESCRIPCION
●	310606-4-00	1	gruppo tensione crochet inf.	tension assembly for lower looper	groupe tension crochet inférieur		
1	308556-0-00	1	astina	rod	tige		
2	705201-0-00	1	rondella	washer	rondelle		
3	740220-2-00	1	vite	screw	vis		
4	741413-2-00	1	vite	screw	vis		
5	302172-0-10	2	passafilo	thread guide	passe-fil		
6	741612-0-00	1	vite	screw	vis		
7	308558-0-00	1	traversino	tie-rod	traverse		
8	741433-2-00	1	vite	screw	vis		
9	206841-0-01	1	passafilo	thread guide	passe-fil		
10	302204-0-10	1	pomoio	knob	pommeau		
11	300310-0-10	1	molla	spring	ressort		
12	704218-2-00	1	rondella	washer	rondelle		
13	200324-0-10	2	disco tensione	tension disc	disque tension		
14	300391-0-10	1	perno a vite	threaded pin	pivot à vis		
15	741642-2-00	1	vite	screw	vis		
16	302168-2-10	1	supporto	support	support		
17	308553-2-00	1	piastra	plate	plaque		
18	721444-2-00	4	vite	screw	vis		
19	308551-0-00	1	squadretta	bracket	équerre		
20	704104-2-00	2	rondella	washer	rondelle		
21	740210-2-00	2	vite	screw	vis		
22	302136-0-12	1	passafilo	thread guide	passe-fil		
23	729012-2-00	3	vite	screw	vis		
24	308137-0-00	1	cavallotto	coupling	cavalier		
25	308201-0-01	1	passafilo	thread guide	passe-fil		
26	724420-2-00	1	vite	screw	vis		
27	741682-0-00	1	vite	screw	vis		
28	704302-4-00	1	rondella	washer	rondelle		
29	302149-0-11	1	passafilo	thread guide	passe-fil		
30	313375-0-01	1	protezione tendifilo sup.	upper thread take-up protection	protection tendeur du fil supérieur		
31	308107-0-00	1	protezione tendifilo inf.	lower thread take-up protection	protection tendeur du fil inférieur		
32	311098-0-00	2	passafilo	thread guide	passe-fil		
33	704210-4-00	2	rondella	washer	rondelle		
34	300483-0-10	2	vite	screw	vis		
35	308203-0-01	2	guidafilo	thread guide	guide-fil		
36	303045-0-10	2	vite	screw	vis		

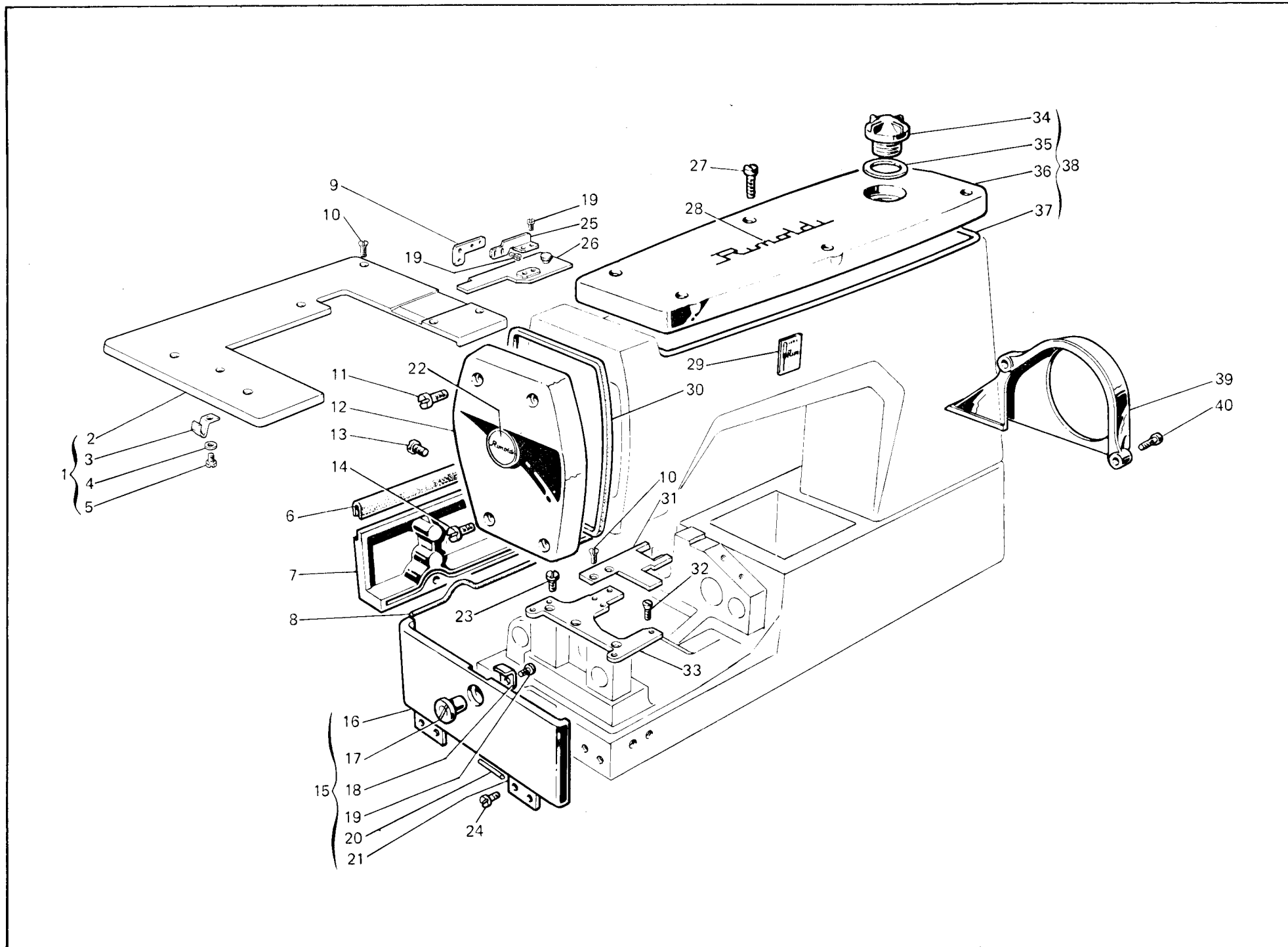

Fig. N. Abb. N.	Part. N. Piece N. Bestell N. Pieza N.	Qt. Anzahl	DESCRIZIONE	DESCRIPTION	DESCRIPTION	BENENNUNG	DESCRIPTION
1	312403-4-00	1	piano di lavoro completo	working plate assembly	plan de travail complet		
2	312404-2-00	1	piano di lavoro	working plate	plan de travail		
3	309351-0-00	1	molla	spring	ressort		
4	704306-2-00	1	rondella	washer	rondelle		
5	720411-2-00	1	vite	screw	vis		
6	309088-0-01	1	guarnizione	gasket	garniture		
7	309089-2-00	1	carter posteriore	rear cover	carter arrière		
8	309084-0-00	1	guarnizione	gasket	garniture		
9	312399-0-00	1	piastrina porta guida	plate	plaque		
10	744636-2-00	7	vite	screw	vis		
11	302354-0-20	2	vite superiore	upper screw	vis supérieur		
12	308100-0-01	1	coperchio laterale	side cover	couvercle latéral		
13	741088-2-00	3	vite fissa carter	screw	vis		
14	302353-0-10	2	vite inferiore	lower screw	vis inférieur		
15	309139-4-00	1	carter laterale compl.	side cover assembly	carter latéral complet		
16	309126-3-00	1	carter laterale	side cover	carter latéral		
17	309372-0-00	1	perno	pin	pivot		
18	309371-0-00	1	chiavistello	key	clé		
19	741658-2-00	5	vite	screw	vis		
20	707556-0-00	2	spina	pin	goupillé		
21	309332-0-00	2	cerniera	hinge	charnière		
22	304662-0-10	1	targhetta	plate	plaque		
23	302355-0-10	2	vite per piastra	screw for plate	vis pour plaque		
24	300483-0-10	4	vite per cerniera	screw for hinge	vis pour charnière		
25	312394-0-00	1	supporto guida	guide support	support guide		
26	309197-2-00	1	coperchio scorrevole	sliding cover	couvercle coulissant		
27	742282-2-00	6	vite	screw	vis		
28	300006-0-12	2	decalcomania	decalcomania	décalcomanie		
29	788020-0-01	2	decalcomania sist. aghi	needles syst. decalcomania	décalcomanie syst. aiguilles		
30	308128-0-00	1	guarnizione	gasket	garniture		
31	312406-0-00	1	carterino	cover	carter		
32	744730-0-00	2	vite per placca ago	screw for needle plate	vis pour plaque à aiguille		
33	312408-2-00	1	piastra porta placca	plate	plaque		
34	202239-0-10	1	cupolina	cup	coupole		
35	705970-0-00	1	guarnizione	gasket	garniture		
36	308102-0-00	1	coperchio superiore	upper cover	couvercle supérieur		
37	308129-0-00	1	guarnizione	gasket	garniture		
38	308103-4-10	1	coperchio superiore completo	upper cover assembly	couvercle supérieur complet		
39	308462-0-00	1	copricinghia per volantino	belt cover	couvre-courroie		
40	721475-2-00	2	vite	screw	vis		

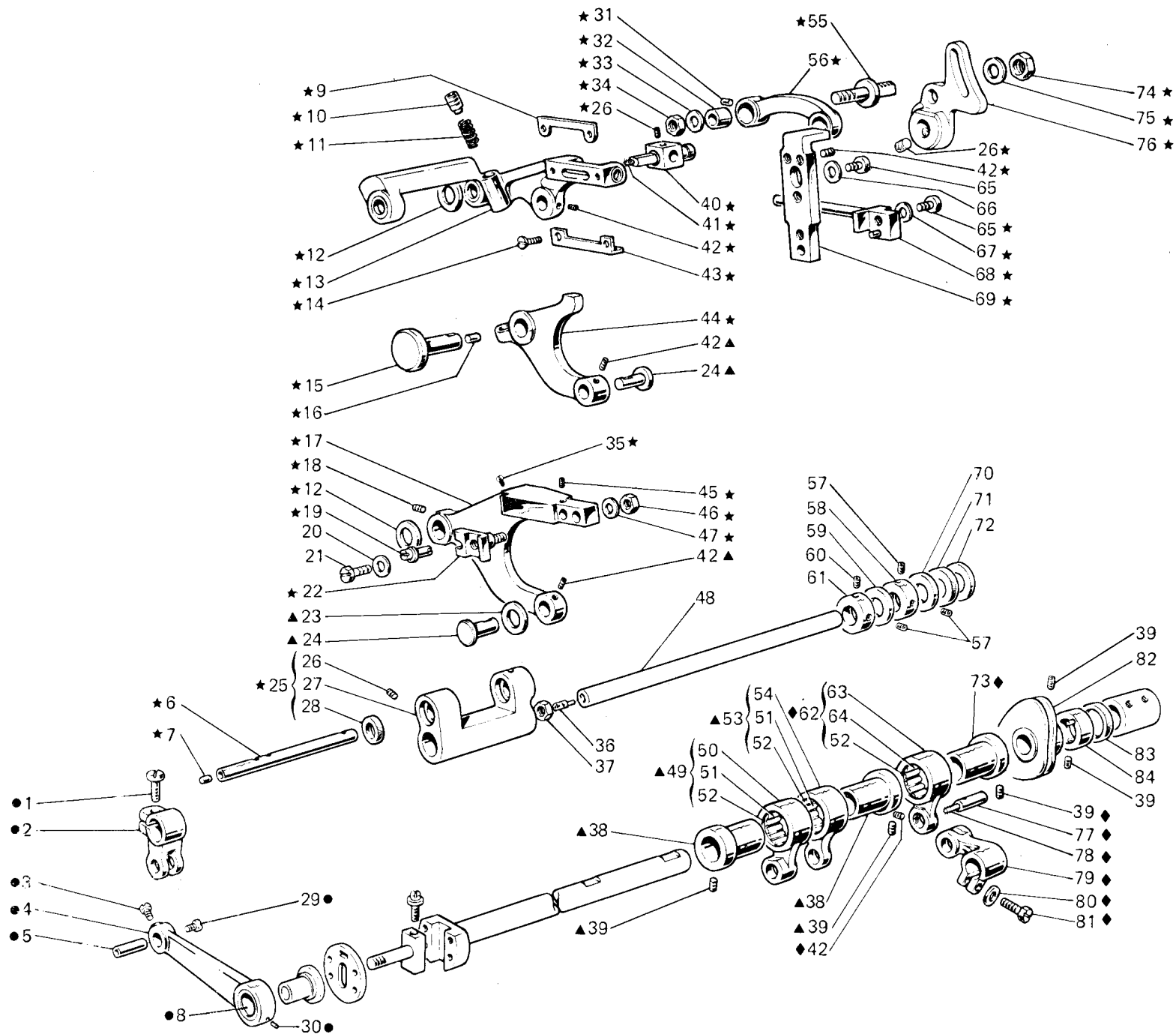

Fig. N. Abb. N.	Part. N. Piece N. Bestell N. Pieza N.	Qt. Anzahl	DESCRIZIONE	DESCRIPTION	DESCRIPTION	BENENNUNG	DESCRIPTION
▲	312443-5-00	1	gruppo porta griffa compl. (con fig. ★)	feed dog holder assembly (with fig. ★)	groupe porte-griffe (avec fig. ★)		
★	312442-4-00	1	gruppo porta griffa	feed dog holder assembly	groupe porte-griffe		
●	308286-4-00	1	gruppo leva	lever assembly	groupe levier		
◆	310630-4-00	1	gruppo comando crochet	looper control assembly	groupe commande crochet		
1	202486-0-10	1	vite	screw	vis		
2	301519-2-11	1	attacco	pipe union	raccord		
3	742813-0-00	1	vite	screw	vis		
4	308283-2-10	1	leva comando porta griffa	lever	levier		
5	308285-2-02	1	perno	pin	pivot		
6	310577-2-00	1	perno con tappo	pin with plug	pivot avec bouchon		
7	301608-0-00	1	tappo	plug	bouchon		
8	303494-0-10	1	cuscinetto	bearing	coussinet		
9	310560-0-00	1	piastrina superiore	upper plate	plaque supérieur		
10	310569-0-00	1	vite	screw	vis		
11	310568-0-01	1	molta	spring	ressort		
12	309560-0-00	3	rondella	washer	rondelle		
13	310554-2-00	1	braccio con bussole	arm with bush	bras avec bague		
14	741722-2-00	2	vite	screw	vis		
15	310556-2-00	1	perno con tappo	pin with plug	pivot avec bouchon		
16	202468-0-10	1	tappo	plug	bouchon		
17	310575-0-01	1	braccio porta griffa	feed dog arm	bras porte-griffe		
18	745815-2-00	1	vite	screw	vis		
19	304612-0-11	1	perno eccentrico	eccentric pin	pivot excentrique		
20	704406-0-00	1	rondella	washer	rondelle		
21	304684-0-10	1	vite fissaggio griffa inf.	lower feed dog fixing screw	vis fixe griffe inférieur		
22	304616-0-11	1	squadretta porta griffa	feed dog bracket	équerre porte griffe		
23	704819-0-00	1	rondella	washer	rondelle		
24	310585-0-00	2	perno per giunto	pin for joint	pivot pour joint		
25	310580-4-01	1	supporto oscillante compl.	oscillating support assembly	support coulissant compl.		
26	729013-2-00	5	vite	screw	vis		
27	310579-2-01	1	supporto oscillante	oscillating support	support coulissant		
28	308190-0-00	2	anello di tenuta	retainer ring	bague d'étanchéité		
29	304640-0-10	1	vite	screw	vis		
30	301586-0-10	1	tappo	plug	bouchon		
31	311253-0-00	1	tappo	plug	bouchon		
32	311051-0-00	1	bussola	bush	bague		
33	704802-0-00	1	rondella	washer	rondelle		
34	733505-2-00	1	dado	nut	écrou		
35	741445-0-00	1	vite	screw	vis		
36	308294-0-10	1	limitatore olio	oil limiter	limiteur huile		
37	746406-2-00	1	dado	nut	écrou		
38	312435-2-00	2	eccentrico con viti	eccentric with screw	excentrique avec vis		
39	727215-0-00	9	vite	screw	vis		
40	310558-2-01	1	perno con vite e stoppini	pin	pivot		
41	778208-0-00	1	stoppino	wick	mèche		
42	745800-2-00	7	vite	screw	vis		
43	310559-0-00	1	piastrina inferiore	lower plate	plaque inférieur		
44	310555-0-00	1	forcella	fork	fourche		

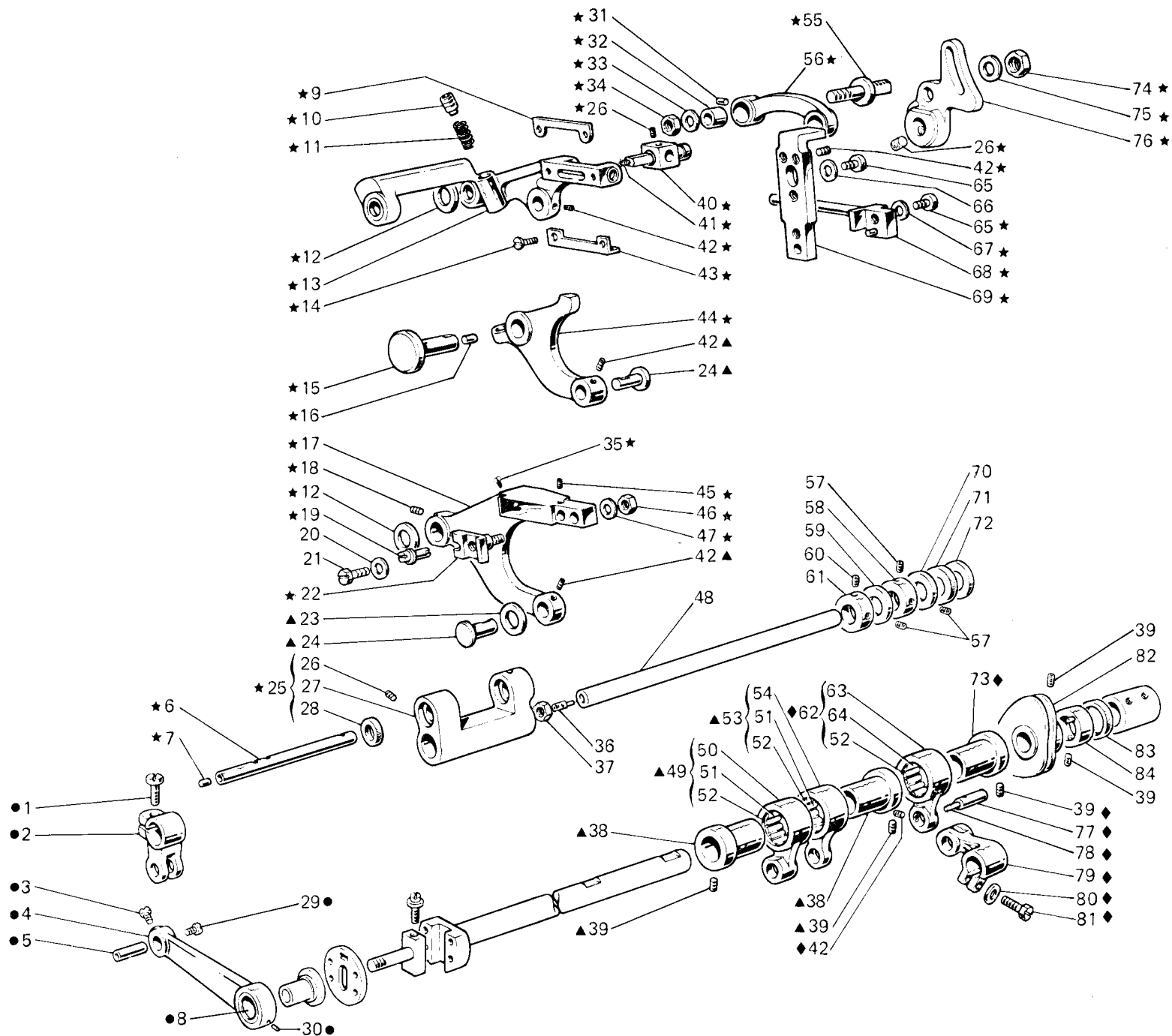



Fig. N. Abb. N.	Part. N. Piece N. Bestell N. Pieza N.	Qt. Anzahl	DESCRIZIONE	DESCRIPTION	DESCRIPTION	BENENNUNG	DESCRIPTION
45	745812-2-00	1	vite	screw	vis		
46	746407-2-00	1	dado	nut	écrou		
47	704226-2-00	1	rondella	washer	rondelle		
48	308289-4-11	1	perno per supporto oscillante	pin for oscillating support	pivot pour support coulissant		
49	310597-4-00	1	giunto compl. per eccentrico	joint assembly	joint compl.		
50	310593-0-00	1	giunto	joint	joint		
51	310583-0-00	2	gabbia a rullini	needles cage	cage à aiguilles		
52	201143-0-10	6	anello di tenuta	retainer ring	bague d'étanchéité		
53	310598-4-00	1	giunto compl. per eccentrico	joint assembly	joint compl.		
54	310594-0-00	1	giunto	joint	joint		
55	310574-0-11	1	perno	pin	pivot		
56	310573-2-00	1	giunto com. slitta con tappo	joint	joint		
57	745136-2-00	3	vite	screw	vis		
58	309838-2-01	1	anello di registro	adjustment ring	bague de réglage		
59	704846-0-00	1	rondella	washer	rondelle		
60	728232-0-00	1	vite	screw	vis		
61	309839-2-01	1	anello di registro	adjustment ring	bague de réglage		
62	310599-4-00	1	giunto compl. per eccentrico	joint assembly	joint compl.		
63	310595-0-00	1	giunto	joint	joint		
64	204786-0-10	1	gabbia a rullini	needles cage	cage à aiguilles		
65	722411-2-00	2	vite	screw	vis		
66	704306-2-00	1	rondella	washer	rondelle		
67	703005-0-00	1	rondella	washer	rondelle		
68	310557-2-10	1	albero porta griffa superiore	shaft	arbre		
69	310615-2-11	1	piastrina porta griffa	plate	plaque		
70	705029-0-00	1	rondella	washer	rondelle		
71	308287-0-00	1	anello di tenuta	retainer ring	bague d'étanchéité		
72	704347-0-00	1	rondella	washer	rondelle		
73	310589-2-00	1	eccentrico con viti fig. 34	eccentric with screw fig. 34	excentrique avec vis fig. 34		
74	746020-2-00	1	dado	nut	écrou		
75	705008-0-00	1	rondella	washer	rondelle		
76	312441-2-00	1	settore con viti	sector with screw	secteur avec vis		
77	307704-0-00	1	perno	pin	pivot		
78	778238-0-00	1	stoppino	wick	mèche		
79	310596-2-00	1	braccio	arm	bras		
80	704218-2-00	1	rondella	washer	rondelle		
81	300377-0-10	1	vite	screw	vis		
82	308971-3-00	1	tendifilo a camma con viti	cam thread take-up with screw	tendeur du fil a came avec vis		
83	308119-0-00	1	anello di tenuta	retainer ring	bague d'étanchéité		
84	308967-2-00	1	anello limitatore	limiter ring	bague limiteur		

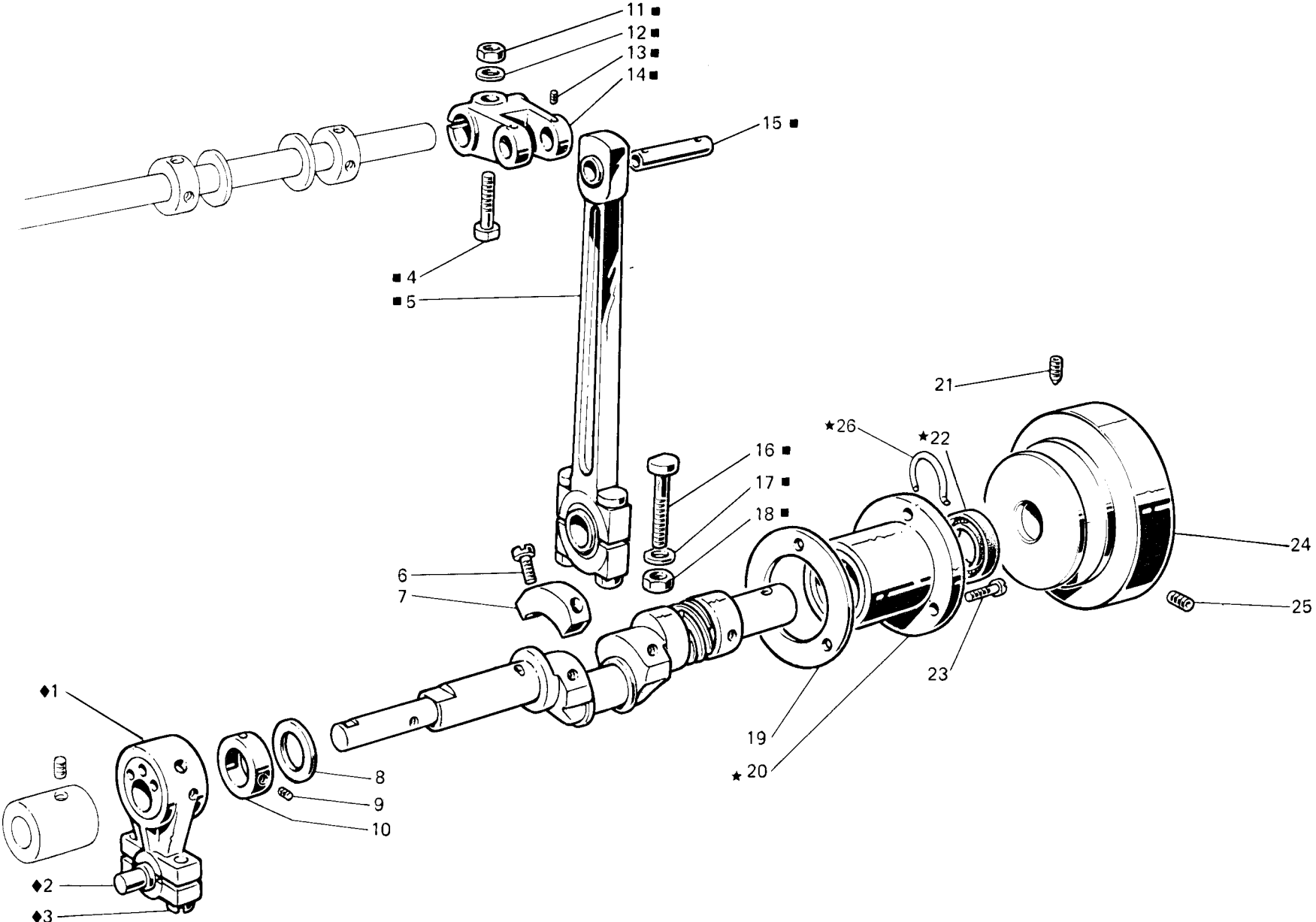

Fig. N. Abb. N.	Part. N. Piece N. Bestell N. Pieza N.	Qt. Anzahl	DESCRIZIONE	DESCRIPTION	DESCRIPTION	BENENNUNG	DESCRIPTION
★	308013-4-02	1	bussola destra completa	right bush assembly			
■	308178-4-01	1	gruppo biella principale	main con-rod assembly	bague droite complète		
◆	310350-4-00	1	gruppo biella completa	con-rod assembly	groupe bielle principale		
1	308253-3-00	1	biella con eccentrico e viti	con-rod with eccentric and screw	groupe bielle		
2	308310-0-00	1	perno a sfera	ball joint	bielle avec excentrique et vis		
3	308802-0-00	2	vite per biella	screw for con-rod	pivot à sphère		
4	308855-0-00	1	vite	screw	vis pour bielle		
5	308174-3-01	1	biella principale completa	main con-rod assembly	vis		
6	741056-0-00	4	vite	screw	bielle principale complète		
7	302272-0-10	2	settore	sector	vis		
8	704869-0-00	1	rondella	washer	secteur		
9	745815-2-00	2	vite	screw	rondelle		
10	308084-2-00	1	anello di registro con viti	adjustment ring with screw	vis		
11	746408-2-00	1	dado	nut	bague de réglage avec vis		
12	705013-0-00	1	rondella	washer	écrou		
13	745812-2-00	2	vite	screw	rondelle		
14	308159-2-01	1	manovella	crank	vis		
15	308166-0-00	1	perno	pin	manivelle		
16	308161-0-00	2	vite	screw	pivot		
17	308149-0-01	2	rondella	washer	vis		
18	308162-0-00	2	dado	nut	rondelle		
19	308127-0-00	1	guarnizione	gasket	écrou		
20	308012-2-10	1	bussola	bush	garniture		
21	730054-2-00	1	vite per volantino	screw for handwheel	bague		
22	700596-0-00	1	anello di tenuta	retainer ring	vis pour volant		
23	742222-2-00	3	vite	screw	bague d'étanchéité		
24	308090-0-01	1	volantino	handwheel	vis		
25	729044-2-00	1	vite	screw	volant		
26	308389-0-00	1	anello elastico	spring ring	vis		
					anneau ressort		

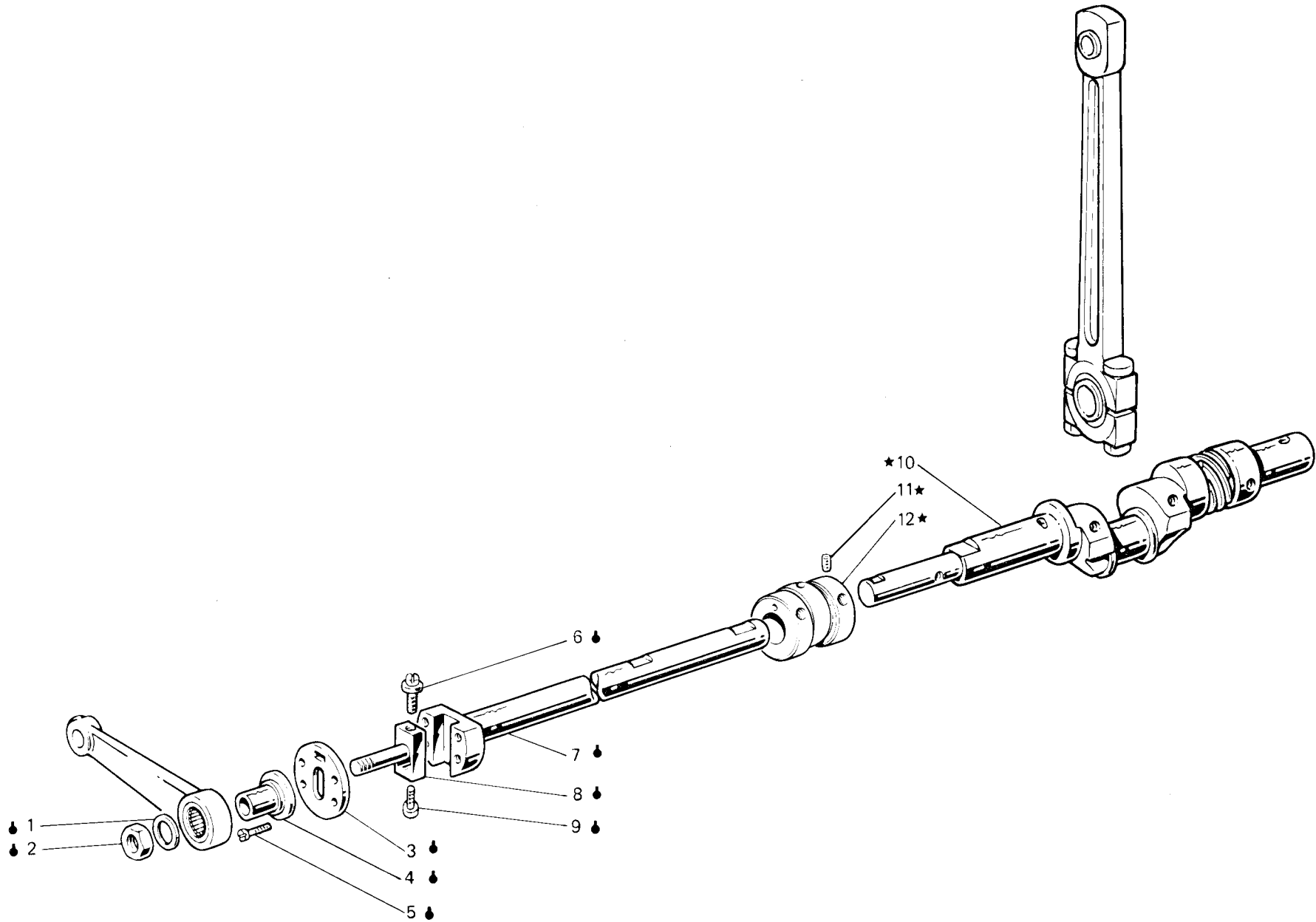

Fig. N. Abb. N.	Part. N. Piece N. Bestell N. Pieza N.	Qt. Anzahl	DESCRIZIONE	DESCRIPTION	DESCRIPTION	BENENNUNG	DESCRIPTION
★	312365-4-00	1	gruppo albero inf. completo (con fig. 1)	lower shaft assembly (with fig. 1)	arbre inférieur complet (avec fig. 1)		
1	308364-4-01	1	semialbero inf. sinistro compl.	left lower shaft assembly	semi-arbre inf. gauche compl.		
2	704814-0-00	1	rondella	washer	rondelle		
3	746612-2-00	1	dado	nut	écrou		
4	308774-2-00	1	piastra a disco	disc plate	plaque		
5	303458-0-12	1	bussola	bush	bague		
6	724441-0-00	4	vite	screw	vis		
7	308281-0-00	1	vite di registro	screw	vis		
8	308386-2-01	1	semialbero	half-shaft	semi-arbre		
9	308278-0-01	1	perno	pin	pivot		
10	308780-2-00	1	vite di registro	screw	vis		
11	308714-3-01	1	semialbero inf. destro	right lower half-shaft	semi-arbre inf. droite		
12	745827-2-00	4	vite per manicotto	screw for coupling	vis pour manchon		
	312362-2-00	1	eccentrico con viti	eccentric	excentrique		

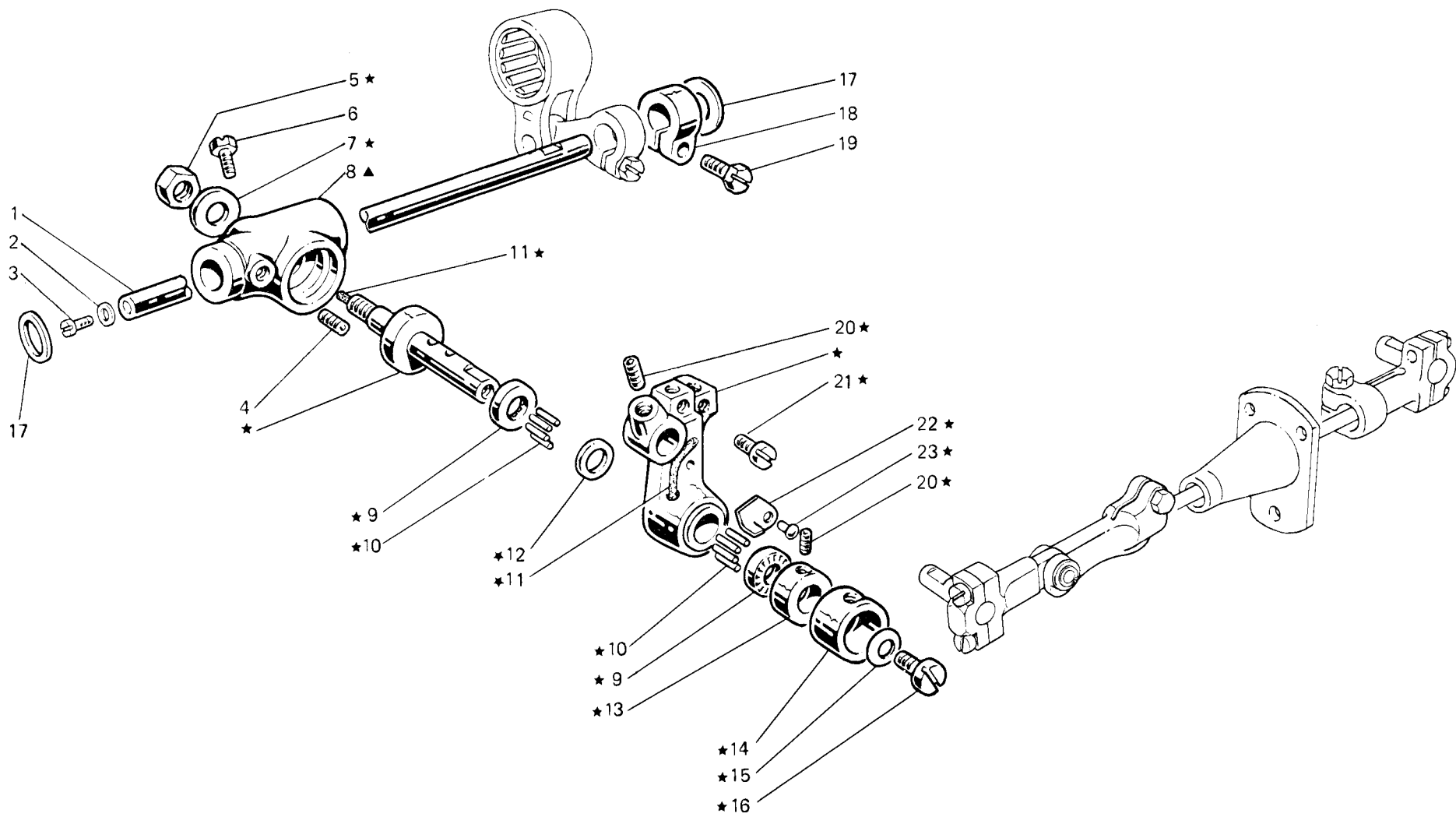

Fig. N. Abb. N.	Part. N. Bestell N. Piecce N. Pieza N.	Qt. Anzahl	DESCRIZIONE	DESCRIPTION	DESCRIPTION	BENENNUNG	DESCRIPCION
▲	308263-4-00	1	gruppo porta crochet inf. (con fig. ★)	lower looper assembly (with fig. ★)	groupe porte-crochet inférieur (avec fig. ★)		
★	312811-3-00	1	gruppo porta crochet	looper holder assembly	groupe porte-crochet		
1	308292-4-00	1	contralb. crochet inf. compl.	lower looper countershaft ass.	axe crochet inférieur compl.		
2	705734-0-00	1	guarnizione	gasket	garniture		
3	202397-0-10	1	vite	screw	vis		
4	730033-2-00	1	vite	screw	vis		
5	202474-0-10	1	dado	nut	écrou		
6	740226-0-00	1	vite per supporto	screw for support	vis pour support		
7	704226-2-00	1	rondella	washer	rondelle		
8	308140-0-00	1	supporto del porta crochet	support for looper holder	support du porte-crochet		
9	303539-0-00	2	reggispinta	thrust	butée		
10	302276-0-10	40	rullino	roller	rouleau		
11	778827-0-00	2	stoppino	wick	mèche		
12	703810-0-00	1	distanziale	spacer	entretoise		
13	302052-2-21	1	ghiera con viti	ring nut with screws	collier avec vis		
14	303538-0-00	1	cappello di protezione	protection cap	capuchon de protection		
15	702403-0-00	1	molla a tazza	cup spring	ressort à tasse		
16	742423-0-00	1	vite	screw	vis		
17	704846-0-00	2	rondella	washer	rondelle		
18	300469-2-11	1	fascetta	clamp	bride		
19	300482-0-10	1	vite	screw	vis		
20	745815-2-00	3	vite	screw	vis		
21	303503-0-10	2	vite fissa crochet	looper fixing screw	vis blocage crochet		
22	308272-0-00	1	piastrina	sheet	plaque		
23	308273-0-00	1	rivetto	rivet	rivet		

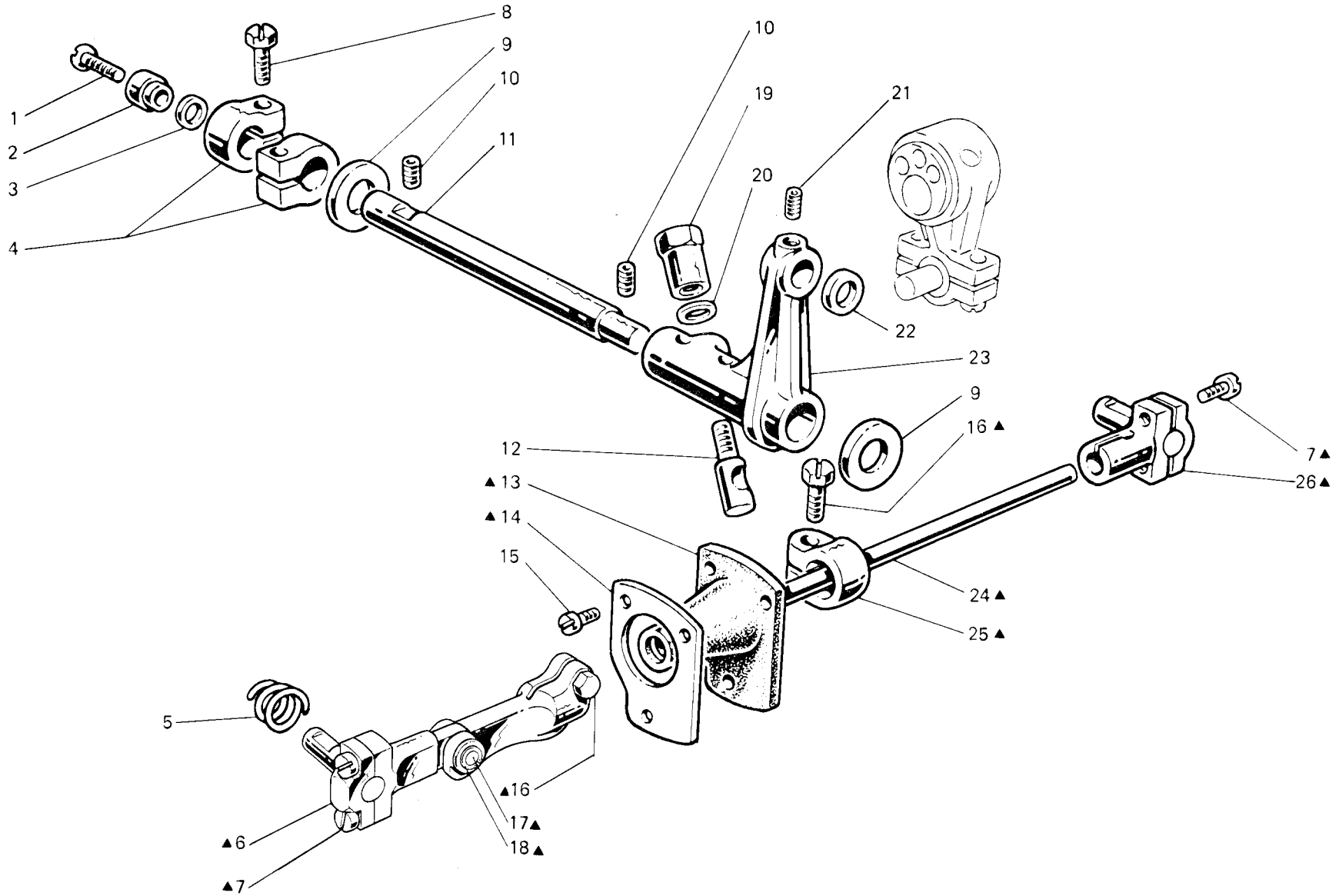



Fig. N. Abb. N.	Part. N. Piecce N. Bestell N. Pieza N.	Qt. Anzahl	DESCRIZIONE	DESCRIPTION	DESCRIPTION	BENENNUNG	DESCRIPCION
▲	308459-4-00	1	gruppo comando crochet inf.	lower looper control assembly	groupe com, crochet inférieur		
1	744676-2-00	1	vite	screw	vis		
2	308047-0-00	1	scodellino	cup	cuvette		
3	701009-0-00	1	anello di tenuta	retainer ring	bague d'étanchéité		
4	308046-2-01	2	fascetta	clamp	bride		
5	302289-0-10	1	molta	spring	ressort		
6	308458-3-00	1	testa di biella completa	con-rod big end assembly	tête de bielle compl.		
7	744040-2-00	4	vite	screw	vis		
8	300482-0-10	2	vite	screw	vis		
9	704849-0-00	2	rondella	washer	rondelle		
10	729434-2-00	2	vite fissa perno	screw	vis		
11	308044-0-00	1	perno per supporto	pin for support	pivot pour support		
12	300352-0-10	1	spina filettata	pin	goupille		
13	308330-3-00	1	manicotto para olio	oil protection	manchon pare huile		
14	308327-0-00	1	mascherina per manicotto	flange	flasque		
15	741675-2-00	2	vite	screw	vis		
16	305194-0-00	2	vite	screw	vis		
17	302393-0-00	1	perno	pin	pivot		
18	700004-0-00	2	anello elastico	spring ring	anneau ressort		
19	300351-0-11	1	dado	nut	écrou		
20	704309-4-00	1	rondella	washer	rondelle		
21	745815-2-00	1	vite	screw	vis		
22	705834-0-00	1	rondella in fibra	washer	rondelle		
23	308045-0-01	1	supporto oscillante	oscillating support	support coulissant		
24	308334-0-01	1	tirante per biella	tie-rod	tirante pour bielle		
25	308326-2-01	1	fascetta per biella con vite	clamp with screw	bride avec vis		
26	308325-3-00	1	testa di biella con viti	con-rod big end with screws	tête de bielle avec vis		

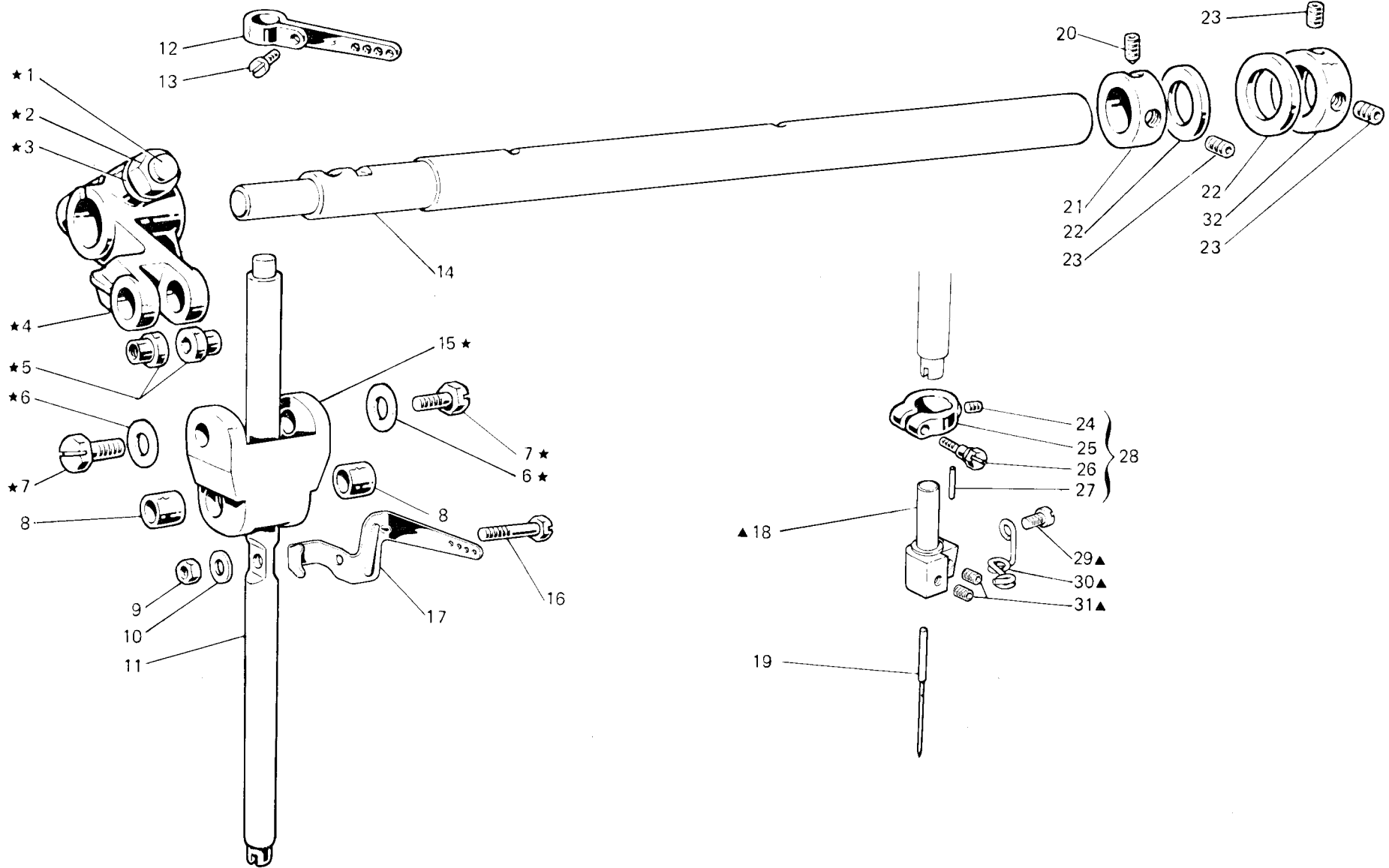

Fig. N. Abb. N.	Part. N. Bestell N. Pièce N. Pieza N.	Qt. Anzahl	DESCRIZIONE	DESCRIPTION	DESCRIPTION	BENENNUNG	DESCRIPCION
★	308006-4-00	1	gruppo manov. giunto barra ago	crank and joint assembly	groupe maniv. joint barre-aiguille		
▲	312434-4-00	1	morsetto porta aghi completo	needle clamp assembly	porte-aiguille complet		
1	308855-0-00	1	perno a vite	threaded pin	pivot à vis		
2	746408-2-00	1	dado	nut	écrou		
3	705013-0-00	1	rondella	washer	rondelle		
4	308036-2-00	1	manovella completa	crank assembly	manivelle compl.		
5	308037-0-00	2	perno superiore	upper pin	pivot supérieur		
6	704210-4-00	2	rondella	washer	rondelle		
7	308039-0-01	2	vite	screw	vis		
8	308041-0-00	2	bussola inferiore	lower bush	bague inférieure		
9	302338-0-10	1	dado	nut	écrou		
10	703005-0-00	1	rondella	washer	rondelle		
11	308221-0-00	1	barra ago	needle bar	barre-aiguille		
12	308452-2-00	1	tendifilo superiore	upper thread take-up	tendeur du fil supérieur		
13	742311-2-00	1	vite	screw	vis		
14	308851-2-01	1	albero superiore	upper shaft	arbre supérieur		
15	308038-0-10	1	giunto barra ago	needle bar joint	joint barre-aiguille		
16	308042-0-00	1	perno per barra ago	pin for needle bar	pivot pour barre-aiguille		
17	308451-0-10	1	tendifilo inferiore	lower thread take-up	tendeur du fil inférieur		
18	312432-2-00	1	morsetto porta aghi	needle clamp	porte-aiguille		
19	766000-6-90	2	ago RIM 63 fin. 90	needle RIM 63 size 90	aiguille RIM 63 jauge 90		
20	730033-2-00	1	vite	screw	vis		
21	309831-2-00	1	anello di registro con viti	adjustment ring with screw	bague de réglage avec vis		
22	704869-0-00	2	rondella	washer	rondelle		
23	729013-2-00	3	vite	screw	vis		
24	745001-0-00	2	vite	screw	vis		
25	312392-2-01	1	fascetta per barra ago	clamp for needle bar	bride pour barre-aiguille		
26	302352-0-10	1	vite	screw	vis		
27	302292-0-10	1	spinetta	pin	goupille		
28	312393-4-00	1	fascetta completa	clamp assembly	bride complète		
29	741433-2-00	1	vite	screw	vis		
30	312433-0-00	1	passafilo	thread guide	passe-fil		
31	745810-2-00	2	vite	screw	vis		
32	309830-2-00	1	anello di registro con viti	adjustment ring with screw	bague de réglage avec vis		

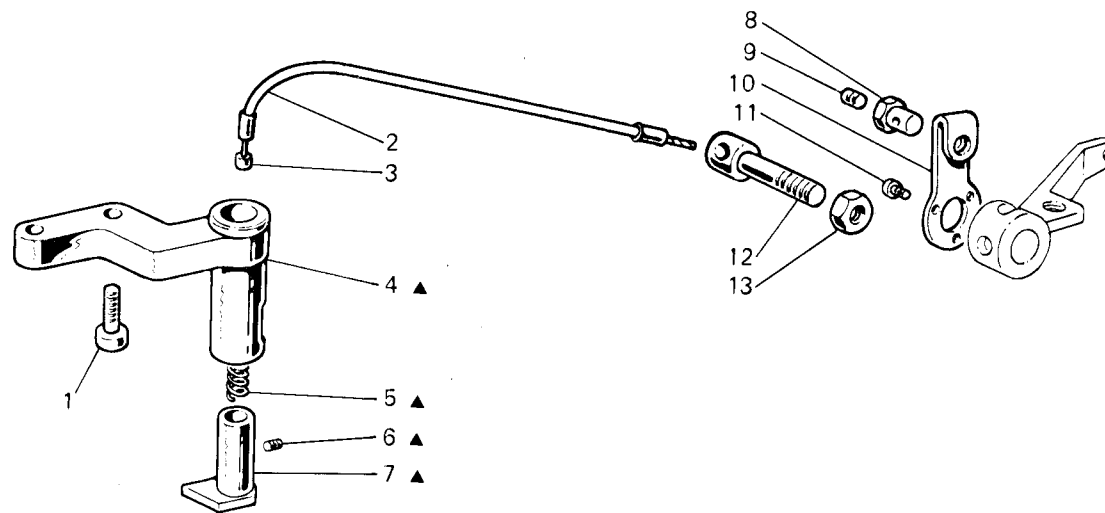

Fig. N. Abb. N.	Part. N. Piece N. Bestell N. Pieza N.	Qt. Anzahl	DESCRIZIONE	DESCRIPTION	DESCRIPTION	BENENNUNG	DESCRIPCION
▲	310611-4-00	1	supporto alza griffa compl.	support assembly	support complet		
1	722432-2-00	2	vite	screw	vis		
2	310612-0-00	1	guaina	sheath	gaine		
3	311377-0-01	1	fune	cable	câble		
4	310610-2-00	1	supporto con bussola	support with bush	support avec bague		
5	204938-0-10	1	molla	spring	ressort		
6	307068-0-00	1	vite	screw	vis		
7	310605-0-00	1	pistoncino	piston	piston		
8	311381-0-00	1	perno	pin	pivot		
9	729022-2-00	1	vite	screw	vis		
10	310614-0-00	1	leva	lever	levier		
11	741675-2-00	3	vite	screw	vis		
12	311378-0-00	1	perno	pin	pivot		
13	746408-2-00	1	dado	nut	écrou		

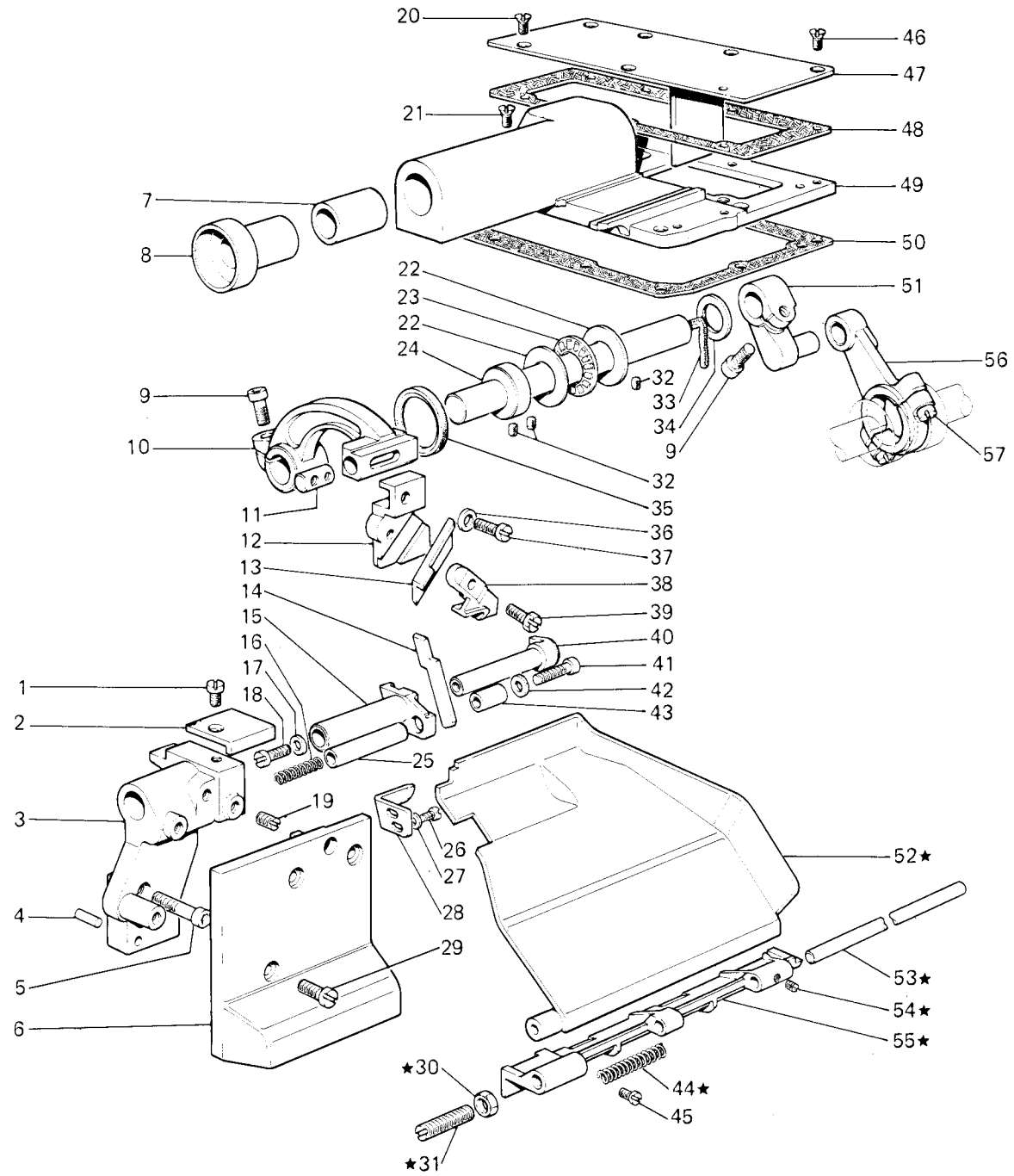

Fig. N. Abb. N.	Part. N. Piece N. Bestell N. Pieza N.	Qt. Anzahl	DESCRIZIONE	DESCRIPTION	DESCRIPTION	BENENNUNG	DESCRIPTION
★	312384-4-00	1	gruppo scarica ritagli	offlet assembly	groupe décharge chutes		
1	744636-2-00	1	vite	screw	vis		
2	312405-0-00	1	piastrina piano lavoro	plate	plaque		
3	312371-2-00	1	supporto coltello inferiore	lower knife support	support couteau inférieur		
4	706455-0-00	2	spina	pin	goupille		
5	722441-2-00	2	vite fissa supporto	screw	vis		
6	312390-0-00	1	carter anteriore sinistro	left front cover	carter avant gauche		
7	102041-0-00	1	bussola di sinistra	left bush	bague gauche		
8	312353-0-00	1	bussola di destra	right bush	bague droite		
9	744334-2-00	2	vite	screw	vis		
10	312360-2-00	1	leva comando coltello con vite	lever	levier		
11	202130-0-11	1	perno	pin	pivot		
12	312361-0-00	1	porta coltello sup.	upper knife holder	porte couteau supérieur		
13	202142-0-10	2	coltello superiore	upper knife	couteau supérieur		
14	312363-0-00	2	coltello inferiore	lower knife	couteau inférieur		
15	312372-0-00	1	porta coltello inf.	lower knife holder	porte couteau inférieur		
16	202128-0-10	1	molla	spring	ressort		
17	704409-0-00	1	rondella	washer	rondelle		
18	742457-2-00	1	vite	screw	vis		
19	727077-0-00	1	vite	screw	vis		
20	724442-2-00	2	vite	screw	vis		
21	741956-2-00	6	vite	screw	vis		
22	207387-0-00	2	rondella	washer	rondelle		
23	207388-0-00	1	cuscinetto	bearing	coussinet		
24	312358-4-00	1	perno con stoppini	pin	pivot		
25	312373-0-00	1	puntale	cap	creaux		
26	741445-2-00	2	vite	screw	vis		
27	704103-2-00	2	rondella	washer	rondelle		
28	312391-0-00	1	molla	spring	ressort		
29	741936-2-00	3	vite	screw	vis		
30	746208-2-00	1	dado	nut	écrou		
31	206769-0-10	1	vite	screw	vis		
32	206708-0-00	3	stoppino	wick	mèche		
33	778427-0-00	1	stoppino	wick	mèche		
34	705034-0-00	1	rondella	washer	rondelle		
35	312354-0-00	1	anello di tenuta	retainer ring	bague d'étanchéité		
36	704206-2-00	1	rondella	washer	rondelle		
37	741747-0-00	1	vite fissa porta coltello	screw	vis		
38	207653-0-01	1	staffa	bracket	équerre		
39	205395-0-11	1	vite	screw	vis		
40	202134-0-11	1	perno	pin	pivot		
41	722471-2-00	1	vite	screw	vis		
42	704406-2-00	1	rondella	washer	rondelle		
43	202129-0-10	1	bussola	bush	bague		
44	206768-0-00	1	molla	spring	ressort		
45	741724-2-00	4	vite	screw	vis		
46	724472-2-00	4	vite	screw	vis		
47	312366-2-00	1	piastra chiusura base	plate	plaque		
48	312368-0-00	1	guarnizione	gasket	garniture		

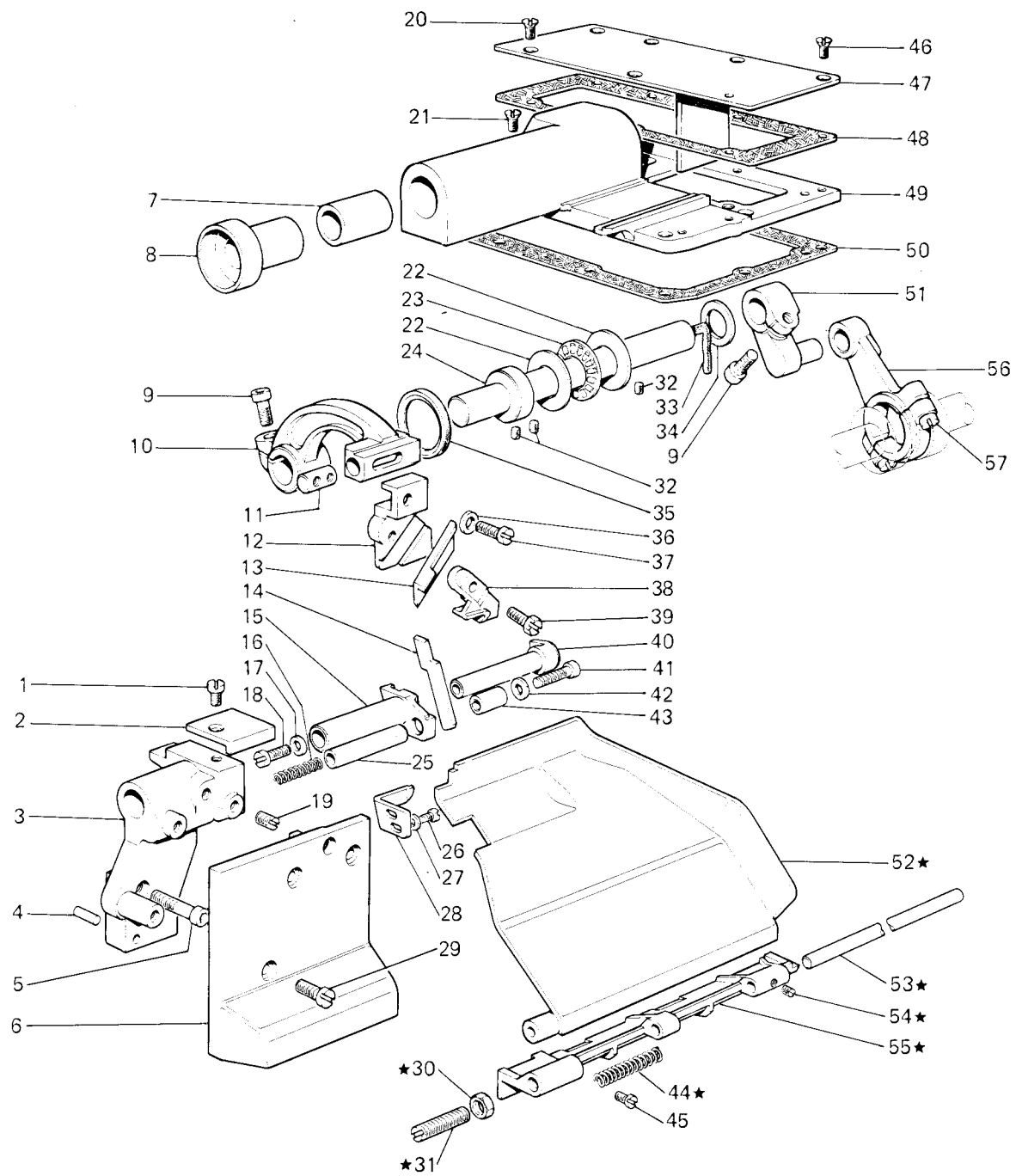



Fig. N. Abb. N.	Part. N. Piece N. Bestell N. Pieza N.	Qt. Anzahl	DESCRIZIONE	DESCRIPTION	DESCRIPTION	BENENNUNG	DESCRIPTION
49	312352-2-00	1	supporto con bussole	support with bush	support avec bague		
50	312357-0-00	1	guarnizione	gasket	garniture		
51	312356-2-00	1	manovella com. coltello con vite	crank	manivelle		
52	312377-2-00	1	scarica ritagli	offlet	décharge chutes		
53	206767-0-00	1	spina	pin	goupille		
54	745800-2-00	1	vite	screw	vis		
55	312376-0-00	1	cerniera	hinge	charnière		
56	312355-0-00	1	biella com. coltello con viti	con-rod	bielle		
57	741984-2-00	2	vite	screw	vis		

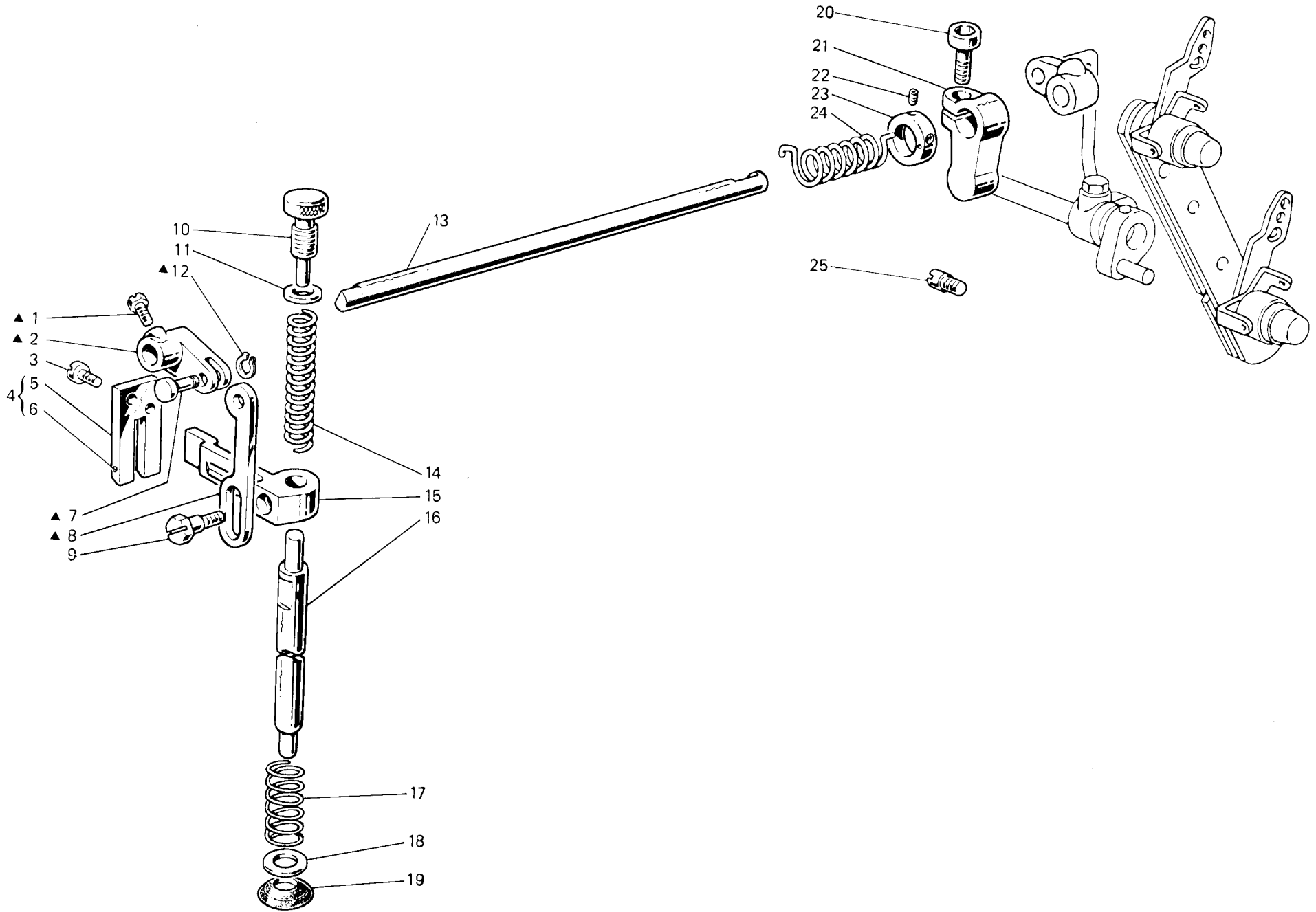

Fig. N. Abb. N.	Part. N. Piece N. Bestell N. Pieza N.	Qt. Anzahl	DESCRIZIONE	DESCRIPTION	DESCRIPTION	BENENNUNG	DESCRIPCION
▲	308060-4-00	1	gruppo manov.tirante premist.	presser crank assembly	groupe maniv. tirant presseur		
i	740632-2-00	1	vite	screw	vis		
2	308059-0-00	1	manovella	crank	manivelle		
3	721494-2-00	2	vite fissa piastra	plate screw	vis blocage plaque		
4	308052-4-00	1	piastra guida barra compl.	plate assembly	plaque complète		
5	308056-0-01	1	piastra guida barra	plate	plaque		
6	707240-0-00	1	spina elastica	split pin	goupille réglable		
7	308058-0-00	1	spina	pin	goupille		
8	308057-0-00	1	tirante per alza piedino	presserfoot tie-rod	tirant soulèv. pied-presseur		
9	740444-2-00	1	vite fissa slitta	screw	vis		
10	302060-0-11	1	pomolo di regolazione	adjustment knob	pommeau de réglage		
11	302344-0-10	1	rondella	washer	rondelle		
12	700205-0-00	1	anello elastico	spring ring	anneau ressort		
13	302234-0-10	1	albero	shaft	arbre		
14	302059-0-10	1	molla premi piedino	spring	ressort		
15	308055-2-00	1	guida a forcella	fork guide	guide a fourchette		
16	308061-0-01	1	barra porta piedino	presserfoot bar	barre porte pied-presseur		
17	308148-0-00	1	molla	spring	ressort		
18	704236-2-00	1	rondella	washer	rondelle		
19	308054-0-01	1	paraolio	oil retainer	pare-huile		
20	744332-2-00	1	vite	screw	vis		
21	308412-2-02	1	fascetta di fermo con vite	clamp with screw	bride de fixation avec vis		
22	745827-2-00	2	vite	screw	vis		
23	304767-2-10	1	anello per molla	ring	bague		
24	308098-0-00	1	molla di torsione	spring	ressort de torsion		
25	308007-0-00	1	perno filettato	threaded pin	pivot fileté		

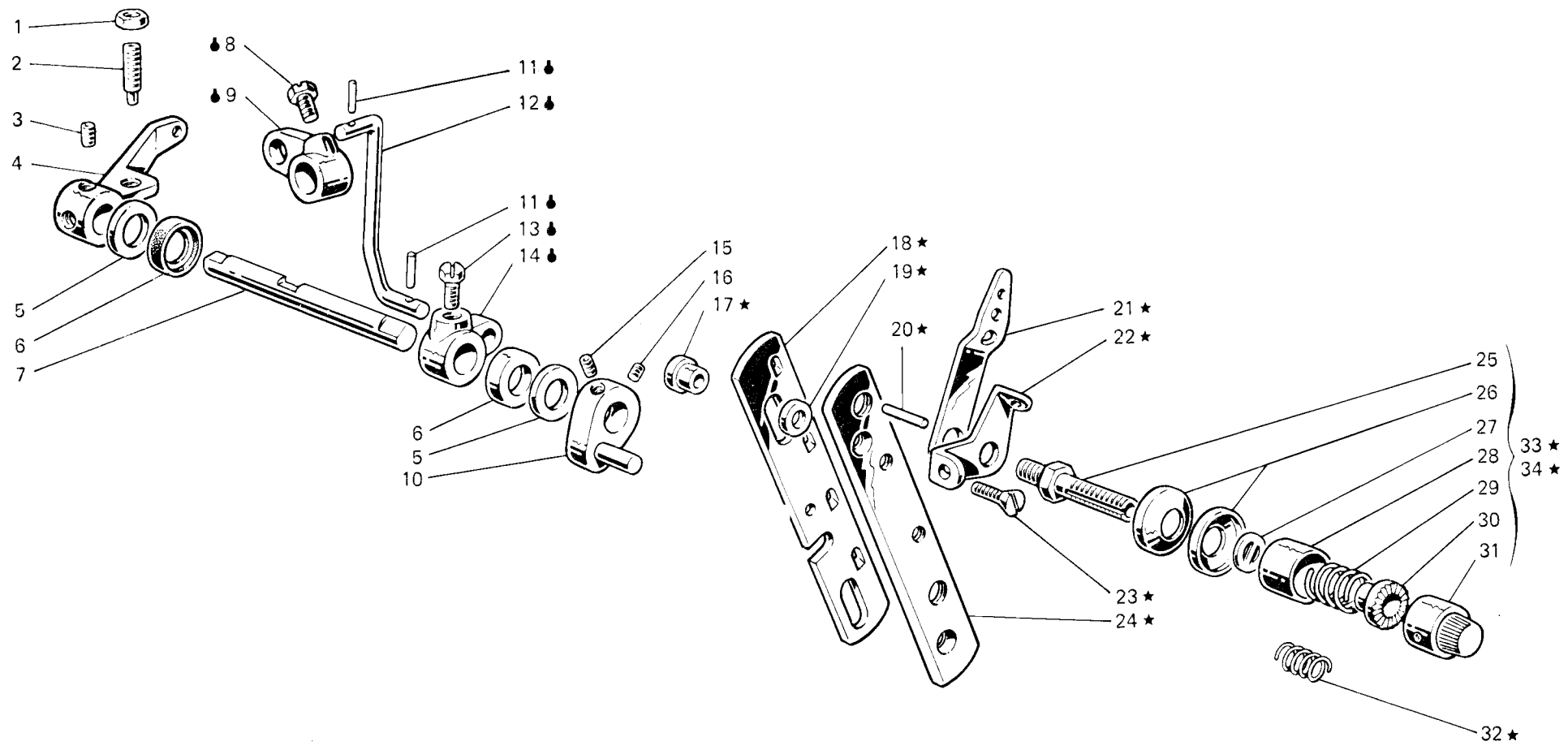

Fig. N. Abb. N.	Part. N. Bestell N. Piece N. Pieza N.	Qt. Anzahl	DESCRIZIONE	DESCRIPTION	DESCRIPTION	BENENNUNG	DESCRIPCION
★	308527-4-00	1	gruppo tensioni	tension assembly	groupe tension		
●	308320-4-00	1	tirante con leva	tie-rod with lever	tirant avec levier		
1	746204-0-00	1	dado	nut	écrou		
2	729884-2-00	1	vite	screw	vis		
3	729034-2-00	2	vite per leva	screw for lever	vis pour levier		
4	311379-2-01	1	leva comando alza piedino	presserfoot control lever	levier soulèv. pied-presseur		
5	704240-2-00	2	rondella	washer	rondelle		
6	304763-0-10	2	anello di tenuta	retainer ring	bague d'étanchéité		
7	308996-0-01	1	albero comando alza piedino	shaft	arbre		
8	740632-2-00	1	vite	screw	vis		
9	302232-0-10	1	leva superiore	upper lever	levier supérieur		
10	308495-2-01	1	leva sblocca tensione	lever	levier		
11	707241-0-00	1	spina elastica	split pin	goupille réglable		
12	308321-0-00	1	tirante	tie-rod	tirant		
13	740034-2-00	1	vite per leva	screw for lever	vis pour levier		
14	302238-0-10	1	leva per tirante	tie-rod lever	levier pour tirant		
15	745126-2-00	1	vite	screw	vis		
16	727834-2-00	1	vite	screw	vis		
17	308512-0-00	2	distanziale	spacer	entretoise		
18	308502-0-00	1	slitta per tensione	slide for tension	glissière pour tension		
19	701405-0-00	2	anello	ring	anneau		
20	308506-0-00	4	pernetto	pin	pivot		
21	308501-0-01	4	passafilo	thread guide	passe-fil		
22	308503-0-01	4	guidafilo	thread guide	guide-fil		
23	744676-2-00	2	vite	screw	vis		
24	308504-0-00	1	supporto	support	support		
25	308505-0-00	4	perno a vite	threaded pin	pivot à vis		
26	300218-0-10	8	disco tensione	tension disc	disque tension		
27	308507-0-00	4	rondella	washer	rondelle		
28	202556-0-00	4	scodellino	cup	cuvette		
29	200710-0-10	2	molla	spring	ressort		
30	202229-0-10	4	bussola superiore	upper bush	bague supérieure		
31	202558-2-00	4	pomoio	knob	pommeau		
32	200714-0-10	2	molla	spring	ressort		
33	308518-4-00	2	tensione sup. con molla fig. 29	upper tension with spring fig. 29	tension sup. avec ressort fig. 29		
34	308521-4-00	2	tensione inf. con molla fig. 32	lower tension with spring fig. 32	tension inf. avec ressort fig. 32		

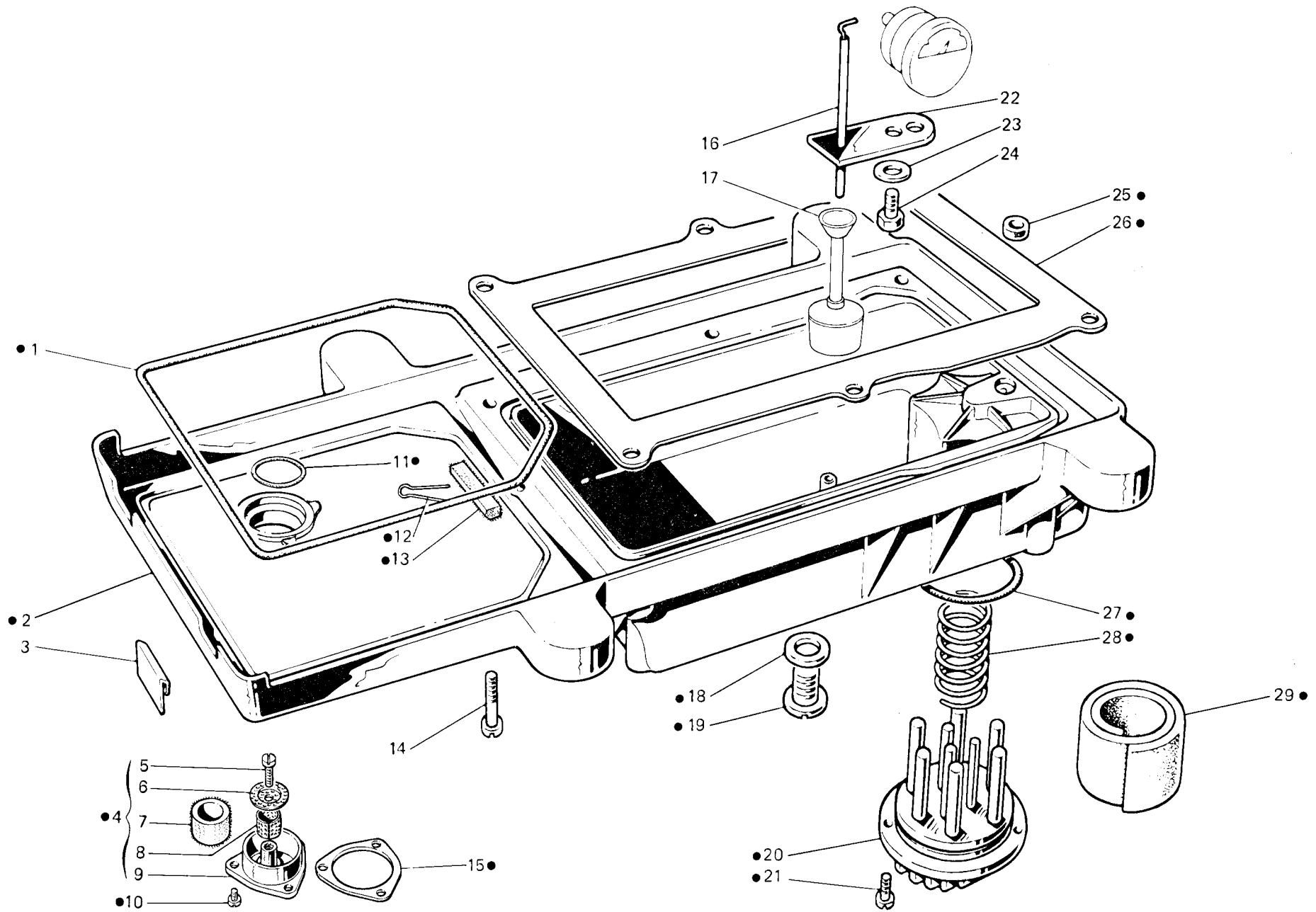

Fig. N. Abb. N.	Part. N. Piecce N. Bestell N. Pieza N.	Qt. Anzahl	DESCRIZIONE	DESCRIPTION	DESCRIPTION	BENENNUNG	DESCRIPCION
●	308588-4-10	1	bacinella olio completa	oil sump assembly	réservoir huile complet		
1	308125-0-01	1	guarnizione	gasket	garniture		
2	308576-2-20	1	bacinella	oil sump	réservoir		
3	308002-0-00	2	piastrina per bacinella	sheet for oil sump	plaquette pour réservoir		
4	308331-4-00	1	tappo completo	plug assembly	bouchon complet		
5	721484-2-00	1	vite	screw	vis		
6	308209-0-00	1	dischetto	disc	disque		
7	308206-0-00	1	filtro olio	oil filter	filtre huile		
8	308210-0-00	1	cilindretto	cylinder	cylindre		
9	308208-0-00	1	tappo	plug	bouchon		
10	722411-2-00	3	vite	screw	vis		
11	701134-0-00	1	guarnizione	gasket	garniture		
12	308957-0-00	1	clip	clip	clip		
13	308213-0-00	1	feltro	felt	feutre		
14	722453-2-00	6	vite fiss. bacinella	oil sump fixing screw	vis blocage réservoir		
15	308179-0-00	1	guarnizione	gasket	garniture		
16	308379-0-00	1	astina livello olio	stick	jauge niveau huile		
17	206665-2-00	1	galleggiante	float	floatteur		
18	705977-0-00	1	rondella	washer	rondelle		
19	206564-0-00	1	tappo	plug	bouchon		
20	206560-0-10	1	coperchio	cover	couvercle		
21	722063-2-00	2	vite	screw	vis		
22	308226-0-02	1	guida astina	guide for stick	guide barre		
23	703003-0-00	1	rondella elastica	spring washer	rondelle élastique		
24	740240-0-00	1	vite	screw	vis		
25	308113-0-00	1	anello	ring	anneau		
26	311395-0-00	1	guarnizione	gasket	garniture		
27	701051-0-00	1	guarnizione	gasket	garniture		
28	206545-0-00	1	molla a spirale	spring	ressort		
29	206559-0-01	1	filtro olio	oil filter	filtre huile		

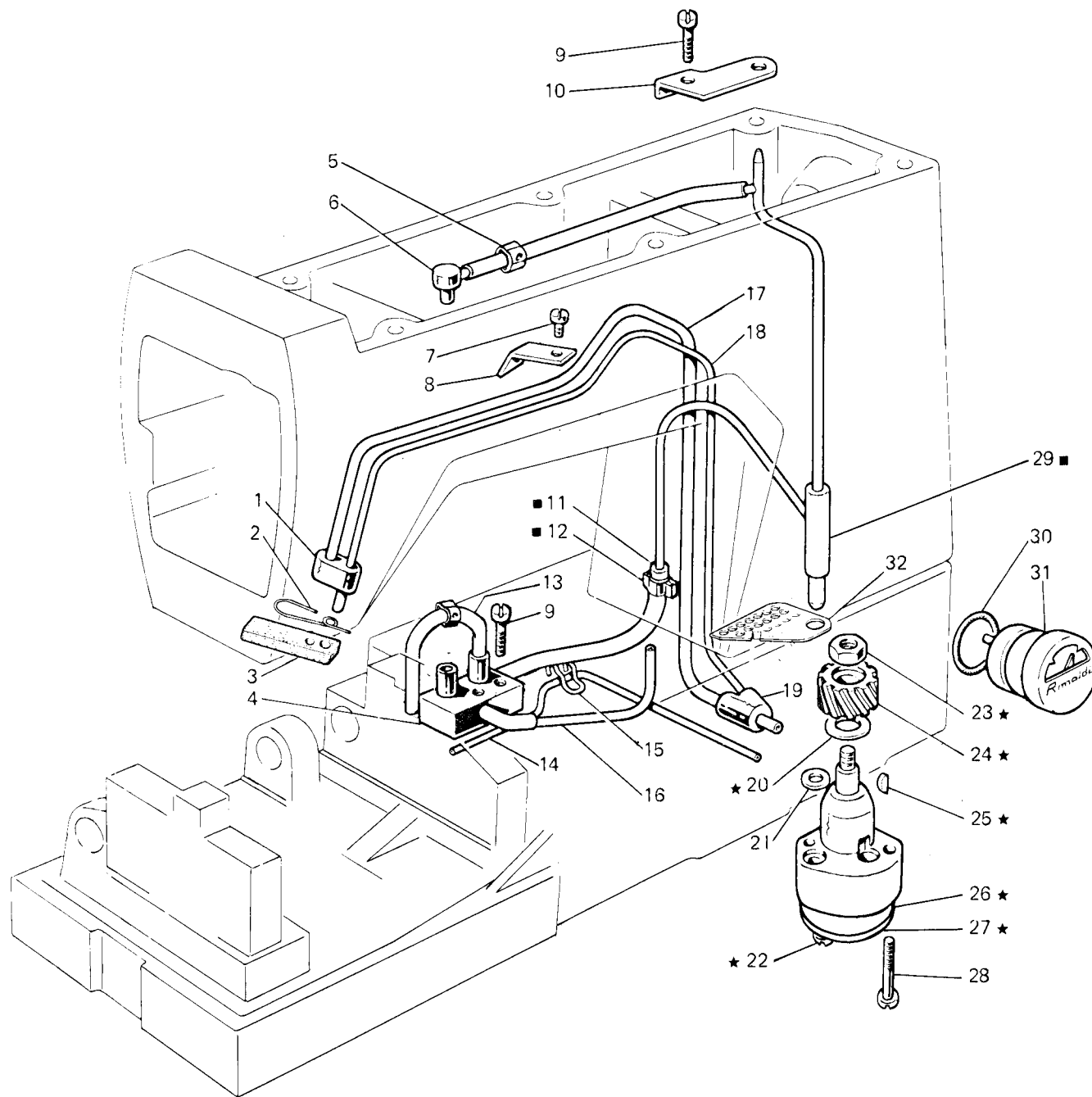



Fig. N. Abb. N.	Part. N. Bestell N. Piece N. Pieza N.	Qt. Anzahl	DESCRIZIONE	DESCRIPTION	DESCRIPTION	BENENNUNG	DESCRIPCION
■	310500-4-00	1	raccordo mandata olio compl.	pipe connection assembly		raccord envoi huile compl.	
★	308105-4-03	1	pompa olio completa	oil pump assembly		pompe à huile complète	
1	308123-0-00	1	raccordo superiore	upper pipe connection		raccord supérieur	
2	307990-0-00	1	molletta	spring		ressort	
3	307991-0-00	1	feltro	felt		feutre	
4	308114-2-02	1	distributore	distributor		distributeur	
5	308040-2-00	1	tubetto	pipe		tube	
6	308214-0-00	1	raccordo mandata olio	pipe connection		raccord	
7	721424-2-00	1	vite	screw		vis	
8	308184-0-00	1	fascetta	clamp		bride	
9	721514-0-00	3	vite	screw		vis	
10	308104-0-00	1	piastrina	plate		plaquette	
11	308207-0-00	1	tubetto	pipe		tube	
12	308043-0-00	1	fascetta	clamp		bride	
13	310561-2-00	1	tubetto	pipe		tube	
14	790325-0-00	1	tubetto	pipe		tube	
15	308211-0-00	2	clip	clip		clip	
16	790315-0-00	1	tubetto	pipe		tube	
17	790342-0-00	1	tubetto recupero olio	pipe		tube	
18	790242-0-00	1	tubetto recupero olio	pipe		tube	
19	308185-0-00	1	raccordo inferiore	lower pipe connection		raccord inférieur	
20	704813-0-00	1	rondella	washer		rondelle	
21	701004-0-00	1	anello di tenuta	retainer ring		bague d'étanchéité	
22	741082-2-00	2	vite	screw		vis	
23	733507-0-00	1	dado	nut		écrou	
24	206555-0-01	1	ingranaggio	gear		engrenage	
25	206557-0-00	1	chiavetta	key		clavette	
26	308110-3-02	1	corpo pompa aspirante	suction pump body		corps pompe admission	
27	308111-0-00	1	coperchio pompa	pump cover		couvercle pompe	
28	741092-0-00	2	vite fissaggio pompa	pump fixing screw		vis fixation pompe	
29	308180-2-00	1	raccordo mandata olio	pipe connection		raccord	
30	701032-0-00	1	anello di tenuta	retainer ring		bague d'étanchéité	
31	206669-2-02	1	indicatore livello olio	oil level gauge		indicateur niveau huile	
32	305666-0-00	1	lamierino	sheet		plaque	

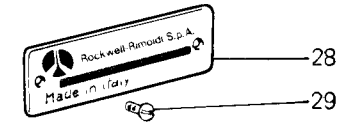
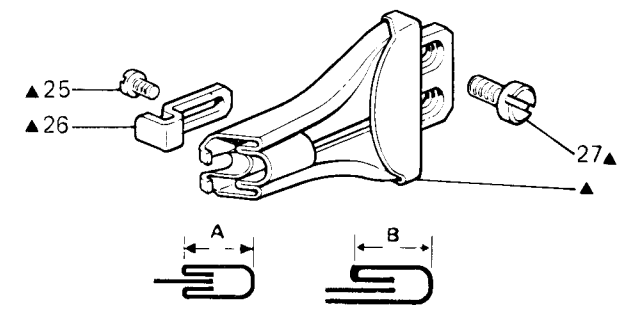
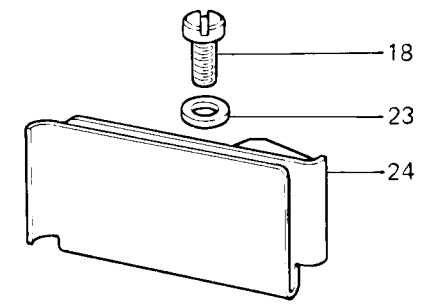
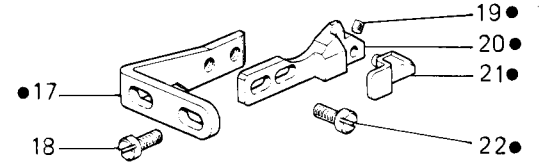
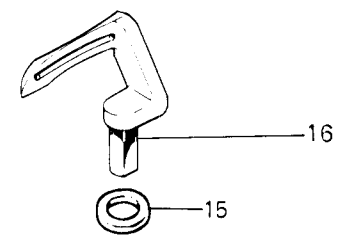
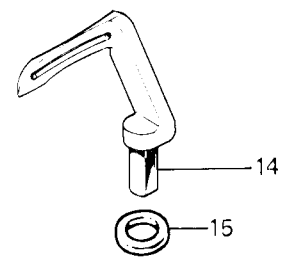
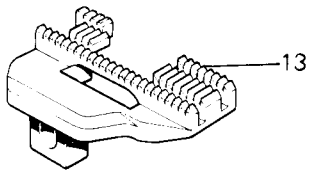
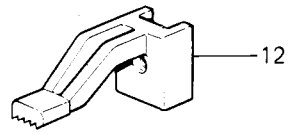
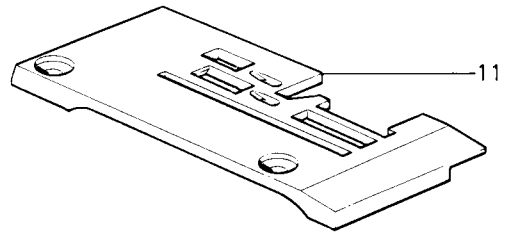
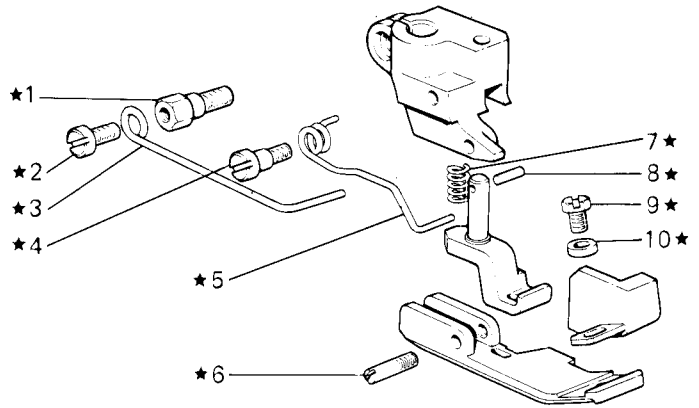

Fig. N. Abb. N.	Part. N. Piece N. Bestell N. Pieza N.	Qt. Anzahl	DESCRIZIONE	DESCRIPTION	DESCRIPTION	BENENNUNG	DESCRIPTION
★	312425-3-00	1	pedino completo	presserfoot assembly	pied-presseur complet		
▲	312448-4-00	1	guida bordatrice A = mm. 8	guide assembly	guide comolet		
●	307395-4-02	1	salva ago completo	rear needle guard assembly	protège-aiguille complet		
1	942722-0-00	1	vite	screw	vis		
2	741658-2-00	1	vite	screw	vis		
3	901397-0-00	1	salvadita	protection	protection		
4	743134-2-00	1	vite	screw	vis		
5	312429-0-00	1	molla	spring	ressort		
6	305489-0-10	1	spina filettata	pin	goupille		
7	301531-0-00	1	molla	spring	ressort		
8	307138-0-00	1	spina	pin	goupille		
9	740210-2-00	1	vite	screw	vis		
10	704104-2-00	1	rondella	washer	rondelle		
11	312424-0-00	1	placca ago	needle plate	plaque à aiguille		
12	312423-0-00	1	griffa superiore	upper feed dog	griffe supérieure		
13	312422-0-00	1	griffa inferiore	lower feed dog	griffe inférieure		
14	303664-0-12	1	crochet inferiore posteriore	rear lower looper	crochet inférieur arrière		
15	703802-0-00	2	rondella	washer	rondelle		
16	303665-0-13	1	crochet inferiore anteriore	front lower looper	crochet inférieur avant		
17	307136-0-01	1	squadra attacco	bracket	équerre		
18	300483-0-10	4	vite	screw	vis		
19	745800-2-00	1	vite	screw	vis		
20	307396-0-11	1	corpo salva ago	body	corps		
21	307394-2-11	1	piastrina con perno	plate	plaque		
22	741937-0-00	2	vite	screw	vis		
23	704505-2-00	2	rondella	washer	rondelle		
24	312395-2-00	1	guida striscia	band guide	guide ruban		
25	741413-2-00	2	vite	screw	vis		
26	312444-0-00	1	squadretta	bracket	équerre		
27	741634-2-00	2	vite	screw	vis		
28	780200-0-40	1	targhetta classe testa	head class plate	plaque classe tête		
29	202165-0-10	2	vite	screw	vis		
			SOLO A RICHIESTA	ONLY ON REQUEST	SEULEMENT SUR DEMANDE		
▲	312445-4-00	1	guida bordatrice A = mm. 5	guide	guide		
	312446-4-00	1	guida bordatrice A = mm. 6,5	guide	guide		
	312447-4-00	1	guida bordatrice B = mm. 6,5	guide	guide		

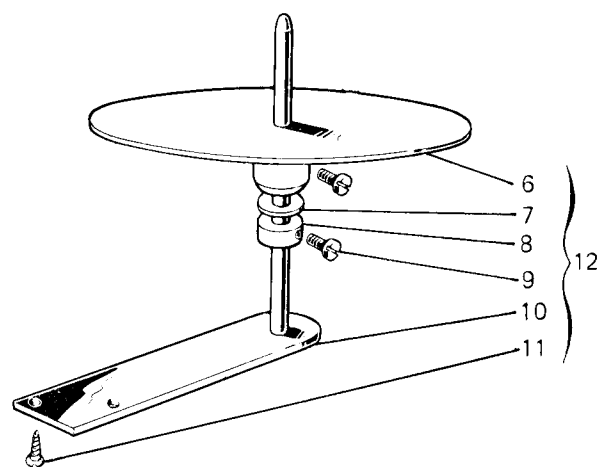
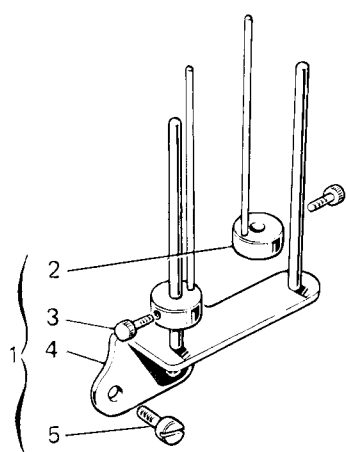

Fig. N. Abb. N.	Part. N. Piece N. Bestell N. Pieza N.	Qt. Anzahl	DESCRIZIONE	DESCRIPTION	DESCRIPTION	BENENNUNG	DESCRIPTION
1	930000-4-12	1	tensione regolabile completa	tension assembly	tension complète		
2	930004-2-21	2	morsetto con spina	clamp with pin	collier de serrage avec goupille		
3	930096-0-10	2	pomolo	knob	pommeau		
4	930006-2-21	1	sostegno	support	support		
5	721486-2-00	2	vite	screw	vis		
6	991582-2-00	1	piatto con mozzo e vite	disc	plateau		
7	311408-0-00	1	rondella	washer	rondelle		
8	991581-2-00	1	anello con viti	ring with screw	anneau avec vis		
9	723266-2-00	2	vite	screw	vis		
10	991321-2-00	1	supporto con asta	support with rod	support avec tige		
11	731107-0-00	2	vite	screw	vis		
12	991580-4-00	1	portarotolo completo	roll carrier assembly	porte-rouleau complet		
13	930105-0-10	1	piastrina	plate	plaque		

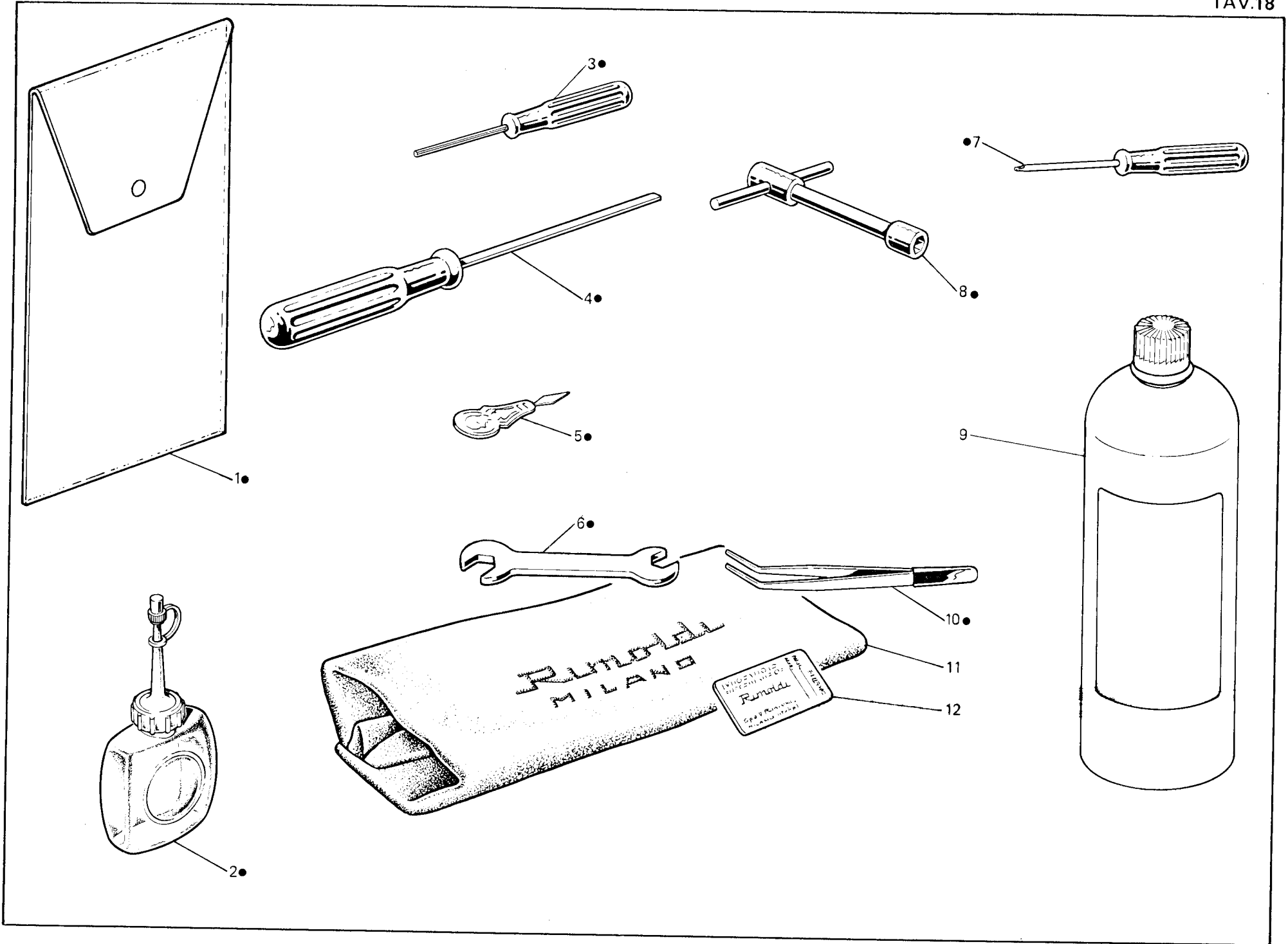

Fig. N. Abb. N.	Part. N. Piece N. Bestell N. Pieza N.	Qt. Anzahl	DESCRIZIONE	DESCRIPTION	DESCRIPTION	BENENNUNG	DESCRIPCION
●	991408-4-02	1	busta accessori completa	accessories envelope assembly	envelope accessoires complète		
1	991415-0-00	1	busta accessori	accessories envelope	envelope accessoires		
2	990175-0-10	1	oliatore	oiler	graisseur		
3	990474-0-11	1	chiave esagonale da 1,5 mm	1,5 mm hexagonal key	clé hexagonale da 1,5 mm		
4	990181-0-10	1	cacciavite medio	screw-driver	tournevis moyen		
5	990723-0-00	1	infilatura aghi	needle threading	enfiles aiguilles		
6	990193-0-00	1	chiave da 5-7 mm	5-7 mm key	clé da 5-7 mm		
7	990069-0-00	1	cacciavite piccolo	screw driver	petite tournevis		
8	990587-0-10	1	chiave a tubo da 9 mm	9 mm key	clé à tube de 9 mm		
9	991280-0-00	1	lattina olio	oil container	bidon huile		
10	990176-0-10	1	pinza per infilatura	threading tweezers	pince pour infilage		
11	990578-0-13	1	cuffia protez.macchina	machine cover	couverture protection machine		
12	★	1	bustina aghi	needle packet	paquette aiguille		
			★per l'ordinazione della bustina citare lo stesso simbolo dell'ago montato sulla testa	★to order packet of needles please specify symbol of needle fitted on machine	★pour commander un sachet d'aiguilles donner le symbol de l'aiguille montée sur la tête		

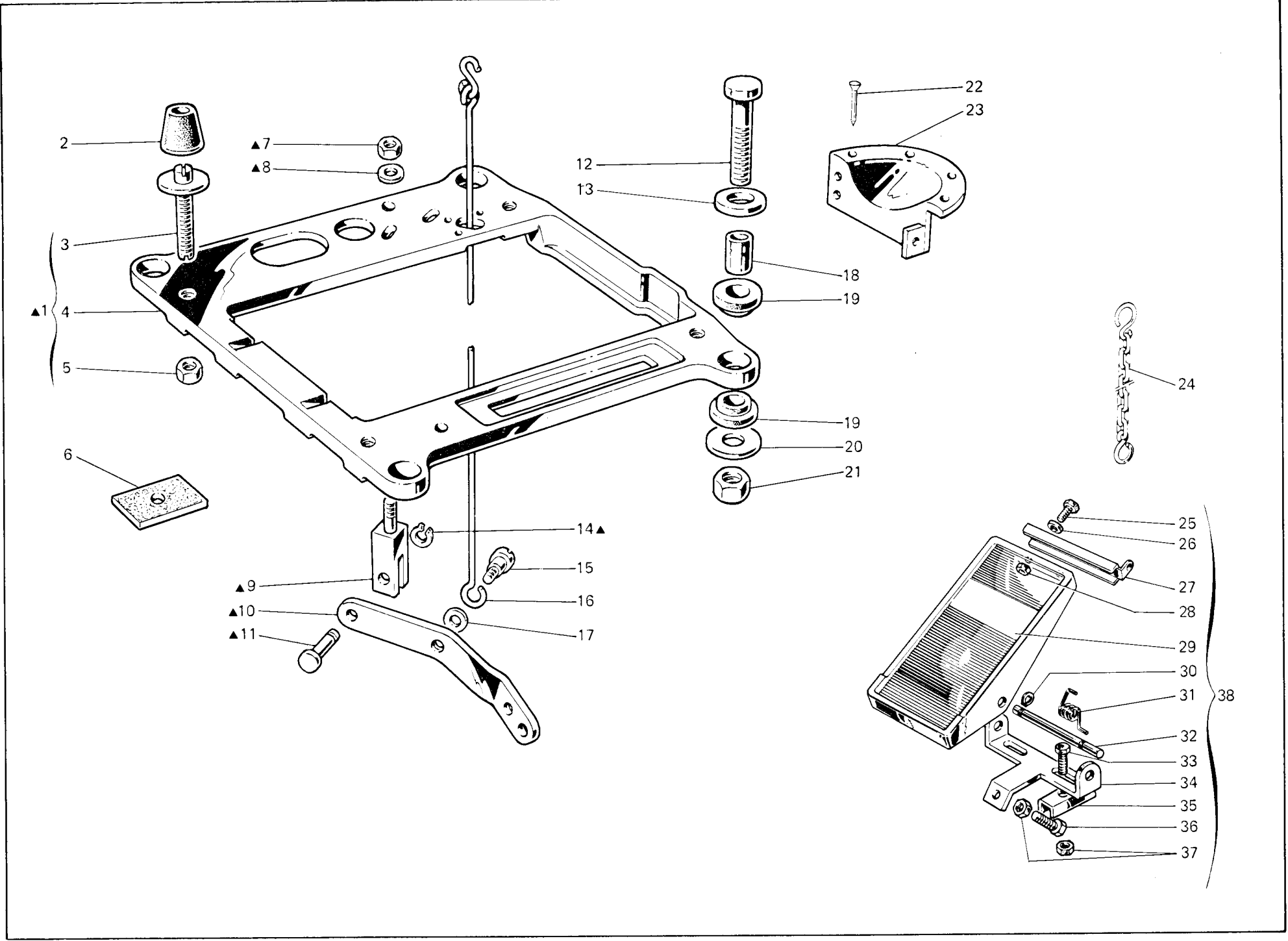



Fig. N. Abb. N.	Part. N. Bestell N. Pieze N. N.	Ct. Anzahl	DESCRIZIONE	DESCRIPTION	DESCRIPTION	BENENNUNG	DESCRIPCION
▲	991253-4-00	1	PIAZZAMENTO NORMALE	NORMAL SETTING	INSTALLATION NORMAL		
1	991251-4-00	1	supporto testa completo	head support assembly	support tête complet		
2	990982-0-00	4	supporto testa con perno	head support with pin	support tête avec pivot		
3	900694-0-11	4	ammortizzatore	shock absorber	amortisseur		
4	991250-0-00	1	perno	pin	pivot		
5	733008-2-00	4	supporto testa	head support	support tête		
6	900203-0-10	4	dado	nut	écrou		
7	746409-2-00	4	ammortizzatore per tavola	shock absorber	amortisseur pour table		
8	704316-2-00	1	dado	nut	écrou		
9	991256-0-00	1	rondella	washer	rondelle		
10	991255-0-00	1	supportino per leva	support for lever	support pour levier		
11	991257-0-00	1	leva	lever	levier		
12	722905-2-00	4	perno	pin	pivot		
13	704346-2-00	4	vite	screw	vis		
14	700208-0-00	1	rondella	washer	rondelle		
15	743541-2-00	1	anello elastico	spring ring	anneau ressort		
16	991259-3-00	1	vite	screw	vis		
17	704310-2-00	1	tirante	tie-rod	tirant		
18	901102-0-00	4	rondella	washer	rondelle		
19	901101-0-00	4	distanziale	spacer	entretoise		
20	704345-2-00	4	ammortizzatore	shock absorber	amortisseur		
21	733813-0-00	4	rondella	washer	rondelle		
22	900201-0-10	7	dado	nut	écrou		
23	990317-0-10	1	chiodini	rivets	clous		
24	990179-4-11	1	protezione volante	handwheel protection	protection volant		
25	720464-4-00	2	catenella	chain	chaînette		
26	704009-4-00	2	vite	screw	vis		
27	900926-0-00	2	rondella	washer	rondelle		
28	733508-4-00	2	attacco	coupling	raccord		
29	900931-0-00	1	dado	nut	écrou		
30	900918-0-00	2	copertura	cover,g	couverture		
31	900927-0-00	2	anello elastico	spring ring	anneau ressort		
32	900928-0-00	1	molla	spring	ressort		
33	720505-4-00	2	perno	pin	pivot		
34	900929-0-01	2	vite	screw	vis		
35	900920-0-00	1	supporto	support	support		
36	720545-4-00	2	piastrina	plate	plaquette		
37	733510-4-00	3	vite	screw	vis		
38	900925-4-01	1	dado	nut	écrou		
			pedalina completa	pedal assembly	pédale complète		

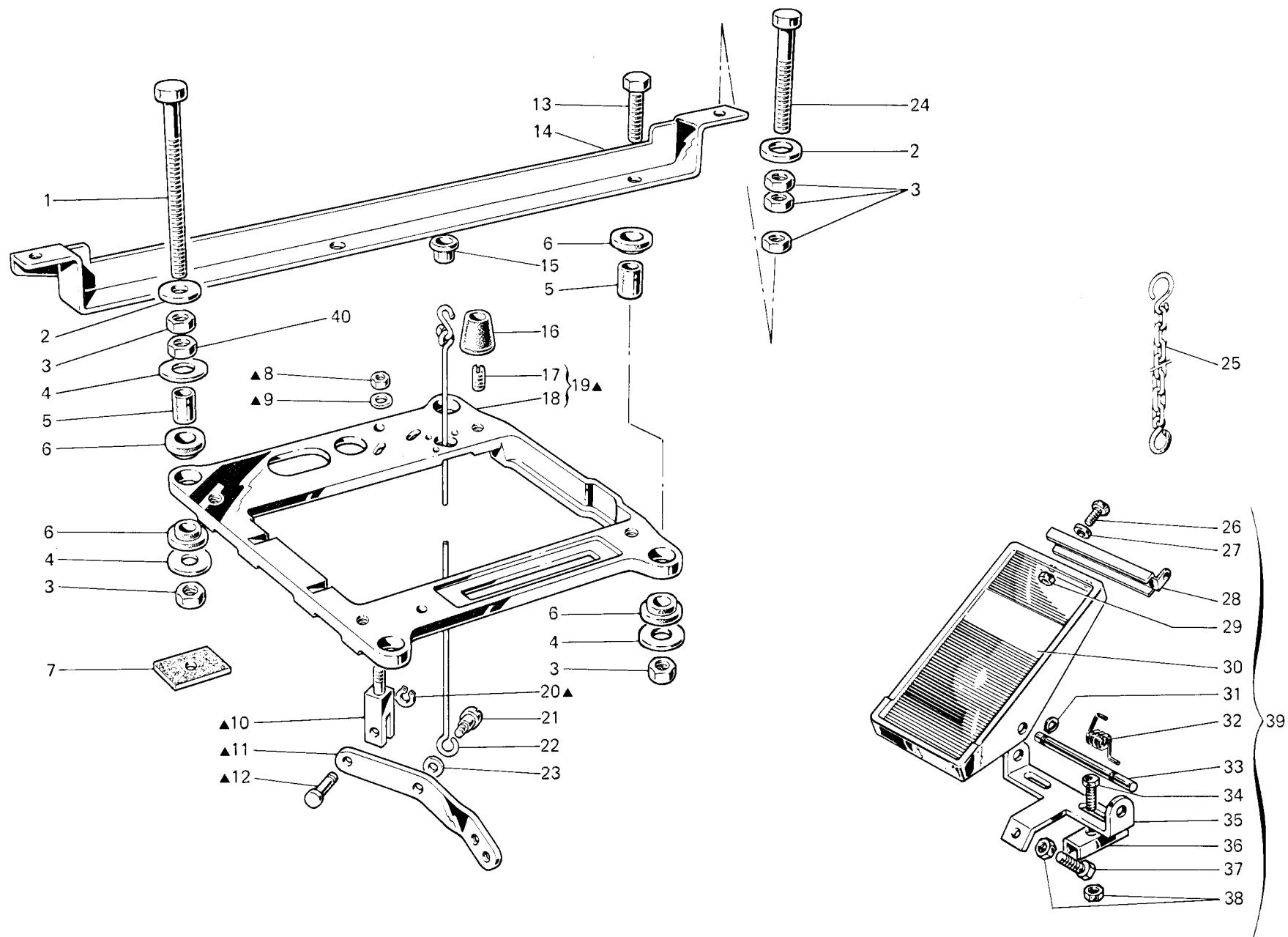

Fig. N. Abb. N.	Part. N. Piece N. Bestell N. Pieza N.	Qt. Anzahl	DESCRIZIONE	DESCRIPTION	DESCRIPTION	BENENNUNG	DESCRIPCION
			PIAZZAMENTO INCASSATO	SUBMERGED SETTING	INSTALLATION ENCASTREE		
▲	991254-4-00	1	supporto testa completo	head support assembly	support tête complet		
1	722920-2-00	2	vite	screw	vis		
2	704346-2-00	4	rondella	washer	rondelle		
3	733813-0-00	10	dado	nut	écrou		
4	704345-2-00	6	rondella	washer	rondelle		
5	901102-0-00	4	distanziale	spacer	entretoise		
6	901101-0-00	8	ammortizzatore	shock absorber	amortisseur		
7	900203-0-10	4	ammortizzatore per tavola	shock absorber	amortisseur pour table		
8	746409-2-00	1	dado	nut	écrou		
9	704316-2-00	1	rondella	washer	rondelle		
10	991256-0-00	1	supportino per leva	support for lever	support pour levier		
11	991255-0-00	1	leva	lever	levier		
12	991257-0-00	1	perno	pin	pivot		
13	720546-0-00	2	vite	screw	vis		
14	901251-2-00	1	staffa	bracket	bride		
15	900204-0-10	1	bussola	bush	bague		
16	990982-0-00	4	ammortizzatore	shock absorber	amortisseur		
17	901253-0-00	4	vite	screw	vis		
18	991250-0-00	1	supporto testa	head support	support tête		
19	991252-4-00	1	supporto testa con viti	head support with screws	support tête avec vis		
20	700208-0-00	1	anello elastico	spring ring	anneau ressort		
21	743541-2-00	1	vite	screw	vis		
22	991259-3-00	1	tirante	tie-rod	tirant		
23	704310-2-00	1	rondella	washer	rondelle		
24	722907-2-00	2	vite	screw	vis		
25	990179-4-11	1	catenella	chain	chaînette		
26	720464-4-00	2	vite	screw	vis		
27	704009-4-00	2	rondella	washer	rondelle		
28	900926-0-00	1	attacco	coupling	raccord		
29	733508-4-00	2	dado	nut	écrou		
30	900931-0-00	1	copertura	covering	couverture		
31	900918-0-00	2	anello elastico	spring ring	anneau ressort		
32	900927-0-00	1	molla	spring	ressort		
33	900928-0-00	1	perno	pin	pivot		
34	720505-4-00	2	vite	screw	vis		
35	900929-0-01	1	supporto	support	support		
36	900920-0-00	2	piastrina	plate	plaque		
37	720545-4-00	1	vite	screw	vis		
38	733510-4-00	3	dado	nut	écrou		
39	900925-4-01	1	pedalina completa	pedal assembly	pédale complète		
40	733008-2-00	4	dado	nut	écrou		

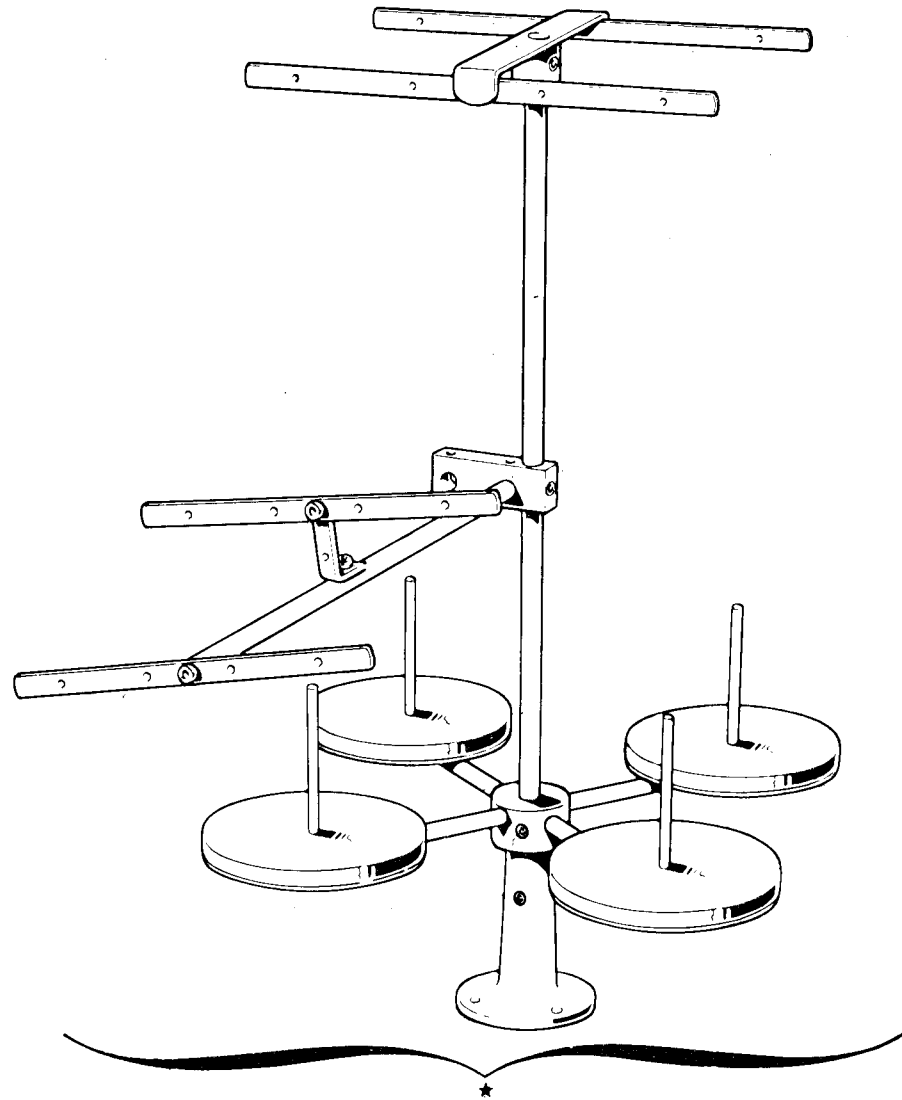

Fig. N. Abb. N.	Part. N. Bestell N. Piece N. Pieza N.	Qt. Anzahl	DESCRIZIONE	DESCRIPTION	DESCRIPTION	BENENNUNG	DESCRIPCION
★	991120-5-01	1	porta bobine compl. (4-3 fili)	bobbin carrier ass. (4-3 threads)	porte bobine compl. (4-3 fils)		