

527-00-1CS-01
527-00-2CS-01
527-00-2MS-01
527-00-2MS-02

EDIZIONE - EDITION 10/81

n. 254

Il presente Catalogo Pezzi di Ricambio è costituito da due parti: la prima, definita come "Catalogo base", comprende i particolari montati sulla testa più significativa (la prima dell'elenco in copertina); la seconda comprende tutti i particolari delle altre teste basi o derivate, che differiscono da quella del Catalogo base.

Le Teste basi sono elencate in copertina con un carattere più grande rispetto a quello delle derivate.

Nella consultazione del Catalogo tenere presente che:

1. Tutti i particolari non fornibili sciolti non vengono richiamati singolarmente, ma soltanto illustrati nel gruppo d'appartenenza.
2. I riferimenti delle figure dei particolari che compongono il gruppo sono di norma raggruppati in una parentesi. In alcuni casi però, dove non è possibile il raggruppamento, i numeri che nelle tavole illustrative richiamano i singoli pezzi sono affiancati dallo stesso segno particolare, con cui è indicato l'intero gruppo.
3. Sulle tavole relative alle altre teste sono elencati tutti i particolari diversi o non montati sulla testa del Catalogo Base. Dette tavole portano in alto a destra il simbolo della testa cui si riferiscono (con indicato fra parentesi - nel caso di derivata - il simbolo della testa da cui deriva).
I disegni di questo gruppo di tavole illustrano soltanto i pezzi nuovi o sostanzialmente diversi rispetto a quelli montati sulla testa più significativa del Catalogo.
I particolari richiamati come simbolo, ma non illustrati, conservano lo stesso numero di figura dei corrispondenti raffigurati sul Catalogo base.
I particolari comuni a tutte le teste comprese nel Catalogo, vengono richiamati soltanto nel primo gruppo di tavole.
I particolari definiti come "pezzi annullati" si intendono quelli non montati sulla testa a cui la tavola si riferisce. Nel caso di un gruppo annullato, viene indicato soltanto il simbolo del gruppo, ma devono intendersi annullati anche tutti i particolari componenti il gruppo stesso.
Per ogni testa viene sempre riportata interamente la tavola relativa agli organi di cucitura.

Per facilitare la ricerca viene riportato l'indice numerico di tutti i particolari illustrati sul Catalogo base, con la relativa tavola in cui gli stessi sono richiamati.

AGHI

Gli aghi sono contraddistinti dal sistema e dalla finezza, la quale indica il diametro medio espresso in centesimi di millimetro.

Il sistema dell'ago e la finezza sono marcati oltre che sulla busta, anche sull'ago stesso.

Nelle ordinazioni precisare, oltre il simbolo, il sistema e la finezza degli aghi desiderati. In caso di dubbio, allegare, un ago campione o una bustina vuota.

AVVERTENZA

Nella richiesta di parti di ricambio citare sempre il relativo numero di matricola della macchina, il simbolo del particolare e la denominazione ufficiale usata sul catalogo.

This spare parts catalogue is made up of two parts: in the first one, called "basic catalogue", all the details of most representative head are listed (the first head listed on the cover); the second one includes the details of the other main heads or derived ones, which are different from that of the basic catalogue.

The main heads are listed on the cover in bigger lettering to distinguish them from the derived heads.

When you consult the catalogue will you please note that:

1. all parts which cannot be supplied by themselves are not indicated alone, but shown together with the group to which they belong;
2. the references of the pictures of the parts making up the group are usually put in brackets.
In some cases, however, when their grouping is not possible, the numbers of the various parts in the tables are marked with the same particular sign with which the whole group is indicated.

3. In the tables of the other heads there are listed all the parts not fitted on the head in the basic catalogue.

These tables are marked at the top right-hand corner with the symbol of the head which the table refers to.

The drawings in this group of tables show only the parts which are new or basically different from those fitted on the most representative head in the catalogue.

The parts which are represented only by the symbol but not illustrated keep the same figure number as the corresponding parts shown in the basic catalogue.

The parts which are common to all the heads in the catalogue are listed only in the first group of tables.

Parts marked "annulled part" are those not fitted on the head which the table refers to. When an assembly has been annulled only the assembly symbol is specified, but all the parts forming the assembly must also be considered annulled.

For each head the table for sewing parts is always repeated completely.

To make it easier to locate the parts, the reference numbers of all of those shown in the basic catalogue are listed together with the number of the table in which they are to be found.

NEEDLES

The needles are marked with system and size; the size indicates the average diameter in hundredths of a millimeter.

The system and size of the needle are shown on the packet as well as on the needle itself.

When ordering please state symbol, system and size. If you have doubts, enclose a sample needle or an empty packet with your order.

ATTENTION

When ordering spare parts always state the serial number of the machine, the symbol of the part in question and the description given in the catalogue.

Ce catalogue "pièces détachées" est formé de deux parties: la première appelée "catalogue base" comprend toutes les pièces montées sur la tête la plus significative (celle en tête de la liste de couverture), la seconde comprend toutes les pièces montées sur les autres têtes de base ou dérivées qui sont différentes de celle du "catalogue base".

Les têtes de base sont énumérées sur la couverture, en caractères plus grands que les têtes dérivées.

Lorsque l'on consulte le catalogue, se souvenir que:

1. Toutes les pièces qui ne sont pas fournies séparément mais qui font partie d'un groupe, ne sont pas indiquées séparément.
2. Les symboles des pièces qui forment un groupe sont regroupés entre parenthèses. Cependant, lorsque ceci n'a pas été possible, les symboles, qui dans les tables d'illustration correspondent aux pièces, sont suivis du même signe particulier qui indique le groupe tout entier.

3. Dans les tables relatives aux autres têtes, nous avons indiqué toutes les pièces différentes de celles de tête du "catalogue base" ou qui ne sont pas montées sur ces dernières. Ces tables portent, en haut à droite, le symbole des têtes auxquelles elles se réfèrent (pour les dérivées, le symbole de la tête de laquelle elles dérivent est indiqué entre parenthèses).

Les dessins de ce groupe de tables représentent seulement les nouvelles pièces ou celles qui sont différentes des pièces montées sur la tête la plus significative du catalogue.

Les pièces indiquées par un symbole, mais qui ne sont pas illustrées, gardent le même numéro de dessin que celles correspondantes, illustrées sur le catalogue base.

Les pièces communes à toutes les têtes du catalogue, sont indiquées seulement dans le premier groupe de tables.

Les pièces définies comme "pièces annulées" sont celles qui ne sont pas montées sur la tête à laquelle se réfère la table. Dans le cas de l'annulation d'un groupe, nous indiquons seulement le symbole du groupe, mais toutes les pièces qui forment ce groupe sont annulées.

Pour chaque tête est toujours indiquée la table se référant aux organes de couture.

Pour faciliter la recherche, le catalogue renferme l'index numérique de toutes les pièces illustrées avec indication de la table dans laquelle elles sont indiquées.

AIGUILLES

Les aiguilles se différencient par le système et la grosseur, laquelle indique le diamètre moyen exprimé en centièmes de millimètre.

Le système de l'aiguille et sa grosseur, sont indiqués non seulement sur le sachet mais également sur l'aiguille.

Dans la commande, préciser, en plus du symbole, le système et la grosseur des aiguilles désirées. En cas de doute, joindre une aiguille comme modèle ou un sachet vide.

ATTENTION

Dans la commande de pièces détachées, indiquer toujours le numéro de la machine, le symbole de la pièce et la dénomination officielle mentionnée sur le catalogue.

INDICE NUMERICO INDEX

Part. N.	Tav. N.	Part. N.	Tav. N.	Part. N.	Tav. N.	Part. N.	Tav. N.	Part. N.	Tav. N.	Part. N.	Tav. N.	Part. N.	Tav. N.
100305-0-10	3	202412-0-11	5	206557-0-00	14	206645-4-02	6	206974-0-00	4	207404-0-00	10	207942-3-00	5
100620-2-10	5	202473-0-11	5	206558-0-01	14	206651-0-00	6	207000-2-00	15	207405-0-00	10	207943-2-00	5
100891-0-10	10	202474-0-10	5	206559-0-01	14	206653-2-01	6	207015-2-00	15	207406-0-00	10	207944-0-00	5
100892-0-10	10	202475-0-10	5	206560-0-20	14	206654-2-10	6	207060-0-00	5	207408-0-00	10	207945-0-00	5
100893-0-10	10	202478-0-10	5	206564-0-00	14	206658-2-02	6	207069-0-01	2	207410-0-00	4	207946-0-01	5
200490-0-00	5	202480-0-10	1	206565-0-01	14	206659-2-01	6	207071-0-00	2	207421-0-00	9	207947-0-00	5
201128-0-10	6	202484-0-10	2	206566-0-00	14	206662-0-00	14	207087-2-00	4	207426-0-01	2	207948-0-00	5
201358-0-10	5	202488-0-10	5	206567-0-01	14	206665-2-00	14	207089-0-00	4	207431-0-01	10	207950-4-00	5
201610-0-01	5	202489-0-10	5	206568-0-01	14	206667-0-00	14	207095-2-00	6	207439-0-00	10	207951-4-00	1
202026-0-10	1	202490-0-10	5	206569-0-01	14	206679-0-00	4	207096-2-00	6	207510-4-00	15	207952-2-00	1
202027-0-10	1	202492-0-10	4	206574-2-00	9	206680-0-01	4	207097-0-02	4	207520-2-00	15	207953-0-00	1
202032-0-11	5	202529-0-10	8	206578-2-00	9	206682-0-01	4	207355-4-10	10	207540-0-00	15	207959-0-00	8
202033-0-10	5	202720-0-00	6	206580-2-00	5	206686-0-00	6	207356-4-02	10	207574-0-00	7	207960-0-00	8
202062-2-10	6	203031-0-10	15	206583-0-00	5	206687-2-00	2	207361-0-00	10	207588-0-00	9	207961-0-00	2
202063-0-10	5	203142-0-10	8	206584-2-00	5	206688-0-00	2	207362-0-00	10	207589-0-00	9	207962-0-00	8
202065-0-20	6	203426-0-10	15	206586-0-01	5	206689-0-01	4	207363-2-00	10	207692-2-00	7	207965-0-00	8
202071-2-20	6	204021-0-10	15	206587-0-01	5	206690-2-00	2	207364-4-00	10	207711-2-10	5	207967-0-00	8
202086-0-11	6	204122-0-10	4-10	206588-0-00	5	206692-0-00	4	207367-0-00	10	207719-0-00	5	207968-0-01	3
202095-0-11	15	204608-0-10	10	206592-3-00	5	206693-0-00	4	207368-0-00	10	207724-2-00	5	207969-0-00	13
202110-0-10	8-10	204947-0-10	8	206593-0-00	5	206695-0-00	6	207369-0-00	10	207758-0-01	1	207970-2-01	14
202112-0-10	10	205021-0-10	10	206594-0-00	5	206697-4-01	4	207370-4-10	10	207856-0-00	2	207971-0-00	14
202128-0-10	9	206296-0-00	1	206595-0-00	5	206699-0-01	4	207373-0-00	10	207858-0-00	2	207972-4-01	14
202129-0-10	9	206400-4-00	6	206598-3-00	5	206702-2-01	4	207374-0-00	10	207861-4-00	9	207973-0-00	14
202130-0-11	9	206409-3-00	6	206599-0-01	5	206705-4-01	4	207375-0-00	10	207876-2-00	8	207975-0-00	14
202132-0-10	9	206421-4-00	6	206602-0-00	5	206708-0-00	4	207377-0-00	10	207878-3-00	8	207976-0-00	13
202133-4-10	9	206452-4-00	6	206603-0-10	5-7	206711-0-00	3	207379-0-00	10	207879-0-00	8	207977-0-00	14
202134-0-11	9	206453-4-00	6	206605-0-01	5	206734-2-00	2	207380-4-10	10	207880-0-00	8	207978-0-00	14
202165-0-10	15	206521-0-00	7	206606-2-00	5-7	206740-0-00	3	207381-0-00	10	207881-2-00	8	207979-0-00	14
202214-0-11	2-8	206533-0-00	7	206613-0-00	5	206748-0-00	1	207382-4-10	10	207882-2-00	8	207990-0-00	7
202267-2-13	3	206538-0-00	7	206615-4-00	5	206755-0-00	3	297383-0-00	10	207887-4-00	8	207991-0-00	7
202279-0-10	3	206539-0-00	9	206617-0-00	5	206756-0-01	2	207384-0-00	10	207893-0-00	3	207992-0-00	15
202281-0-10	3	206540-2-00	7	206618-0-10	5	206757-0-00	9	207387-0-00	10	207895-0-00	3	207995-0-00	15
202292-0-10	5	206543-0-01	4	206619-0-00	5	206758-0-10	9	207388-0-00	10	207901-0-01	14	207998-2-00	7
202345-2-31	5	206544-0-00	4	206620-0-00	8	206764-0-00	2	207389-0-00	10	207909-0-00	14	207999-0-00	7
202371-0-10	8	206545-0-00	14	206621-0-00	8	206767-0-00	2	207390-0-00	10	207912-0-00	3	208012-4-01	14
202385-0-10	5	206546-0-00	5	206622-0-00	8	206768-0-00	2	207391-0-01	10	207916-0-00	3	208015-0-00	6
202386-0-10	4	206549-2-00	7	206632-2-00	8	206769-0-10	2	207392-0-00	10	207917-0-00	14	208019-0-00	13
202389-0-10	10	206550-4-03	14	206635-0-00	8	206808-0-01	8	207394-0-00	10	207922-3-10	7	208031-2-00	2
202391-0-11	8	206554-0-02	14	206637-0-00	8	206810-2-00	8	207395-3-10	10	207927-0-01	7	208039-4-00	6
202397-0-10	3	206555-0-01	14	206642-0-00	8	206812-0-00	3	207399-4-10	4	207930-0-01	7	208057-0-00	3
202408-0-10	5	206556-0-01	4	206643-0-01	6	206872-0-00	5	207402-2-00	4	207932-0-10	7	208059-0-00	10

INDICE NUMERICO INDEX

Part. N.	Tav. N.	Part. N.	Tav. N.	Part. N.	Tav. N.	Part. N.	Tav. N.	Part. N.	Tav. N.	Part. N.	Tav. N.	Part. N.	Tav. N.
208060-4-00	2	701005-0-00	14	720431-2-00	10	733505-2-00	8	745002-0-00	6-7	778842-0-00	13	942946-0-00	10
208080-2-00	2	701007-0-00	5	721410-0-00	11	733507-0-00	14	745114-0-00	7-8	780227-0-40	15	943158-2-00	11
208087-3-00	14	701031-0-00	14	721434-2-00	8	733508-2-00	11	745168-0-00	6	788001-0-01	3	943159-0-00	11
208089-0-00	3	701051-0-00	14	721435-2-00	2	740041-2-00	13	745317-0-00	4	921459-0-10	15	943208-0-01	15
208090-0-00	3	701106-0-00	14	721483-0-00	11	740053-2-00	5	745800-2-00	2-3-6-10	922453-4-00	12	943209-3-00	15
208091-0-00	3	701113-0-00	6	721484-2-00	3-14	740257-2-00	11		13	922454-0-00	12	943211-0-00	15
208097-4-00	5	701116-0-00	4	721494-2-00	14	741405-0-00	7	745810-2-00	6-10-15	922455-0-00	12	943212-0-00	15
208119-4-00	3	701133-0-00	4	721883-0-00	6	741413-0-00	5	745812-0-00	7	922463-0-00	12	943213-0-00	15
208133-2-00	8	701151-0-00	14	722031-2-00	1	741413-2-00	15	745812-2-00	5-6-8-10	922464-0-00	12	943214-0-00	15
208135-4-00	8	703007-0-00	11	722063-2-00	2-4-5-8-14	741415-0-00	6	745815-2-00	5-10	923918-0-01	11	944160-4-01	11
208140-4-10	7	704009-4-00	5	722073-2-00	13	741415-2-00	15	746007-2-00	2-8-12-14	923919-0-01	11	944161-2-01	11
208142-3-01	7	704104-2-00	11-12	722123-2-00	8	741535-0-00	14	746008-0-00	5	923936-0-01	11	944162-0-01	11
208144-0-00	13	704108-2-00	11	722410-2-00	11	741546-2-00	5-10	746020-2-00	8	923942-0-00	11	944164-0-00	11
208148-4-00	13	704218-2-00	11	722411-2-00	10	741552-0-00	7	746021-2-00	11	923943-0-00	11	944165-2-00	11
208161-4-01	7	704226-2-00	12	722421-2-00	10	741558-0-00	3	746208-2-00	2	923978-2-00	11	990075-0-13	16
208163-4-00	7	704306-0-00	11	722432-2-00	10	741634-2-00	13	746402-2-00	11	923985-0-00	11	990183-0-13	16
208164-0-00	2	704308-4-00	5	722471-2-00	9	741675-0-00	3	748086-2-00	14	923989-4-00	11	990335-0-10	14
208179-2-00	3	704310-2-00	11	722480-2-00	7	741675-2-00	12-15	765200-6-80	7	923994-0-00	11	990934-0-00	16
208184-2-00	3	704314-2-00	5-11	722490-2-00	10	741721-2-00	4	770031-0-00	4	925207-4-00	12		
208196-3-00	3	704406-0-00	9	722511-2-00	14	741724-0-00	2	778202-0-00	6	925213-4-00	12		
208204-2-00	3	704409-0-00	9	724032-0-00	5-7	741745-2-00	5	778204-0-00	7-8	925216-0-00	12		
208207-0-00	13	704608-0-00	10	724895-2-00	5	741931-0-00	11	778206-0-00	15	925217-0-00	12		
208208-0-00	13	704805-0-00	10	727014-2-00	7	741956-2-00	3-4	778208-0-00	7	925448-0-00	10		
208209-0-00	13	704808-0-00	5	727021-0-00	15	741963-0-00	11	778236-0-00	6	925761-0-01	12		
208219-3-00	13	704813-0-00	14	727096-0-00	8	741974-2-00	11	778237-0-00	13	926753-2-01	11		
208310-4-00	3	704829-0-00	5	727884-0-00	5	742457-2-00	9	778241-0-00	1	926754-2-01	11		
301586-0-10	8-14	704841-0-00	5	729011-2-00	10	742623-2-00	12	778401-0-00	6	926755-4-01	11		
301608-0-00	2	704845-0-00	6	729012-2-00	7-10-12	742758-0-00	9	778403-0-00	6	926758-0-00	11		
304412-0-10	4	704848-0-00	6	729013-2-00	13	742838-2-00	2	778405-0-00	6	927398-0-00	11		
304413-0-10	4	705008-0-00	5	729022-2-00	14	743243-2-00	6-10	778410-0-00	6	941047-0-01	11		
304451-0-10	4	705029-0-00	7-9	729032-2-00	5	743471-2-00	7-9	778414-0-00	7	942930-4-00	10		
304462-0-20	4	705036-0-00	10	729033-2-00	10	743482-2-00	12	778415-0-00	10	942931-2-00	10		
307605-0-00	11-12	705208-0-00	5	729034-2-00	7	744332-2-00	5-8	778417-0-00	2-5-7	942934-2-00	10		
309562-0-00	7	705230-0-00	5	729051-2-00	5-7-8-10	744334-2-00	5-7-9	778419-0-00	7	942938-0-00	10		
310167-0-00	7	705408-0-00	5	729062-2-00	12	744512-4-00	5	778503-0-00	7	942939-0-00	10		
700206-0-00	10	705970-0-00	14	729434-2-00	4	744530-0-00	11	778511-0-00	7	942940-0-00	10		
700207-0-00	5-11	705975-0-00	1	730011-2-00	5	744533-0-00	9	778522-0-00	8	942941-0-00	10		
700630-0-00	4	705977-0-00	14	730022-2-00	10	744631-2-00	3-12	778832-0-00	2	942942-0-00	10		
701000-0-00	12	705982-0-00	1	730023-2-00	2	744634-2-00	2	778833-0-00	2	942943-0-00	10		
701002-0-00	14	707300-0-00	10	730061-2-00	4	744742-0-00	1	778835-0-00	9	942944-0-00	10		
701004-0-00	5-14	720411-2-00	14	733503-0-00	3	745001-0-00	11	778837-0-00	7-13	942945-0-00	10		

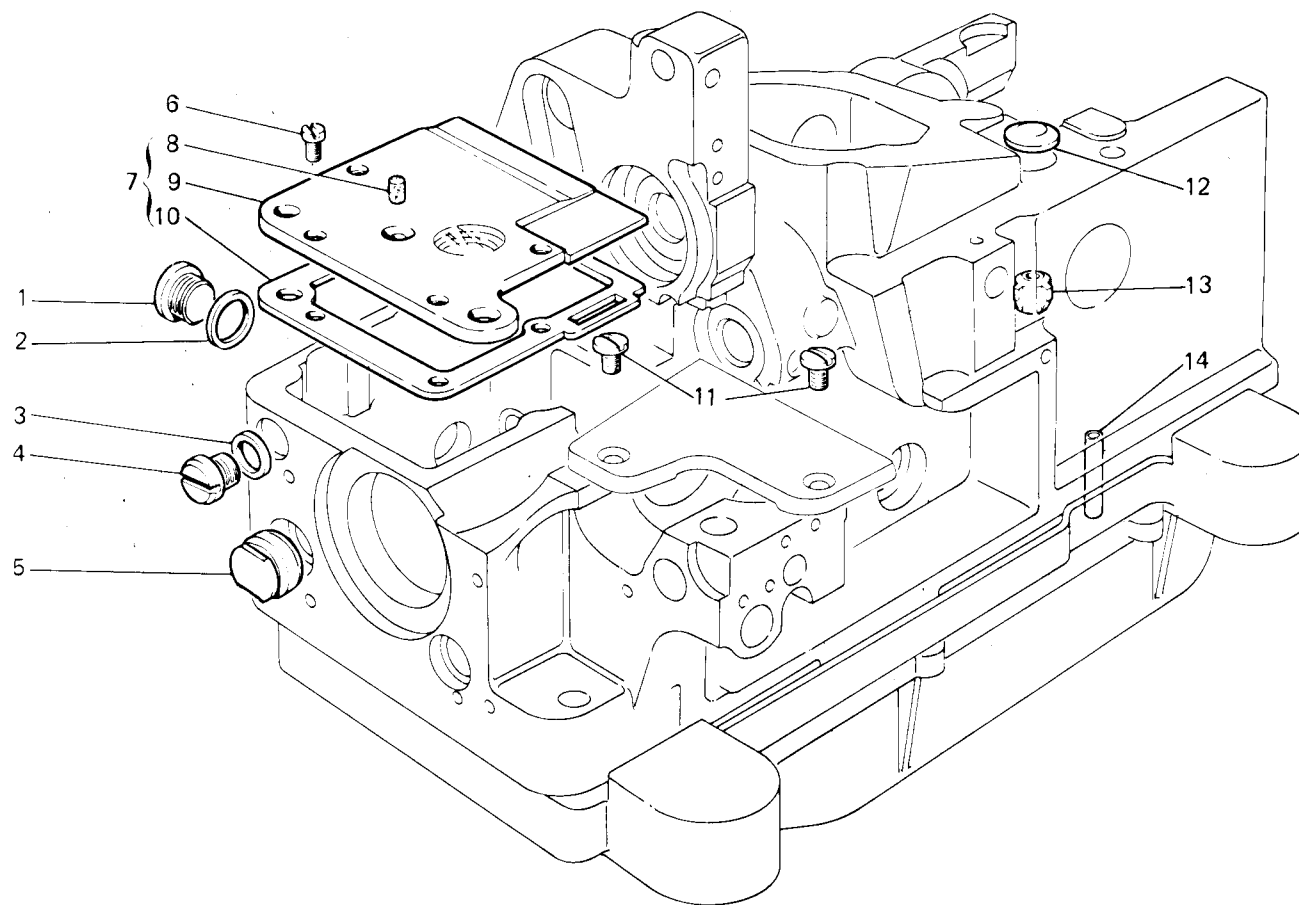

Fig. N. Abb. N.	Part. N. Bestell N. Piece N. Pieza N.	Qt. Anzahl	DESCRIZIONE	DESCRIPTION	DESCRIPTION	BENENNUNG	DESCRIPCION
1	202026-0-10	1	tappo	plug	bouchon		
2	705982-0-00	1	guarnizione	gasket	garniture		
3	705975-0-00	1	guarnizione	gasket	garniture		
4	202480-0-10	1	tappo	plug	bouchon		
5	202027-0-10	1	tappo	plug	bouchon		
6	722031-2-00	4	vite	screw	vis		
7	207951-4-00	1	coperchio completo	cover assembly	couvercle complet		
8	778241-0-00	1	stoppino	wick	mèche		
9	207952-2-00	1	coperchio	cover	couvercle		
10	207953-0-00	1	guarnizione	gasket	garniture		
11	744742-0-00	2	vite fissa placca ago	screw	vis		
12	206748-0-00	1	tappo espansione	plug	bouchon		
13	206296-0-00	1	tubetto scarico olio	pipe	tube		
14	207758-0-01	1	bussola guida astina	bush	bague		

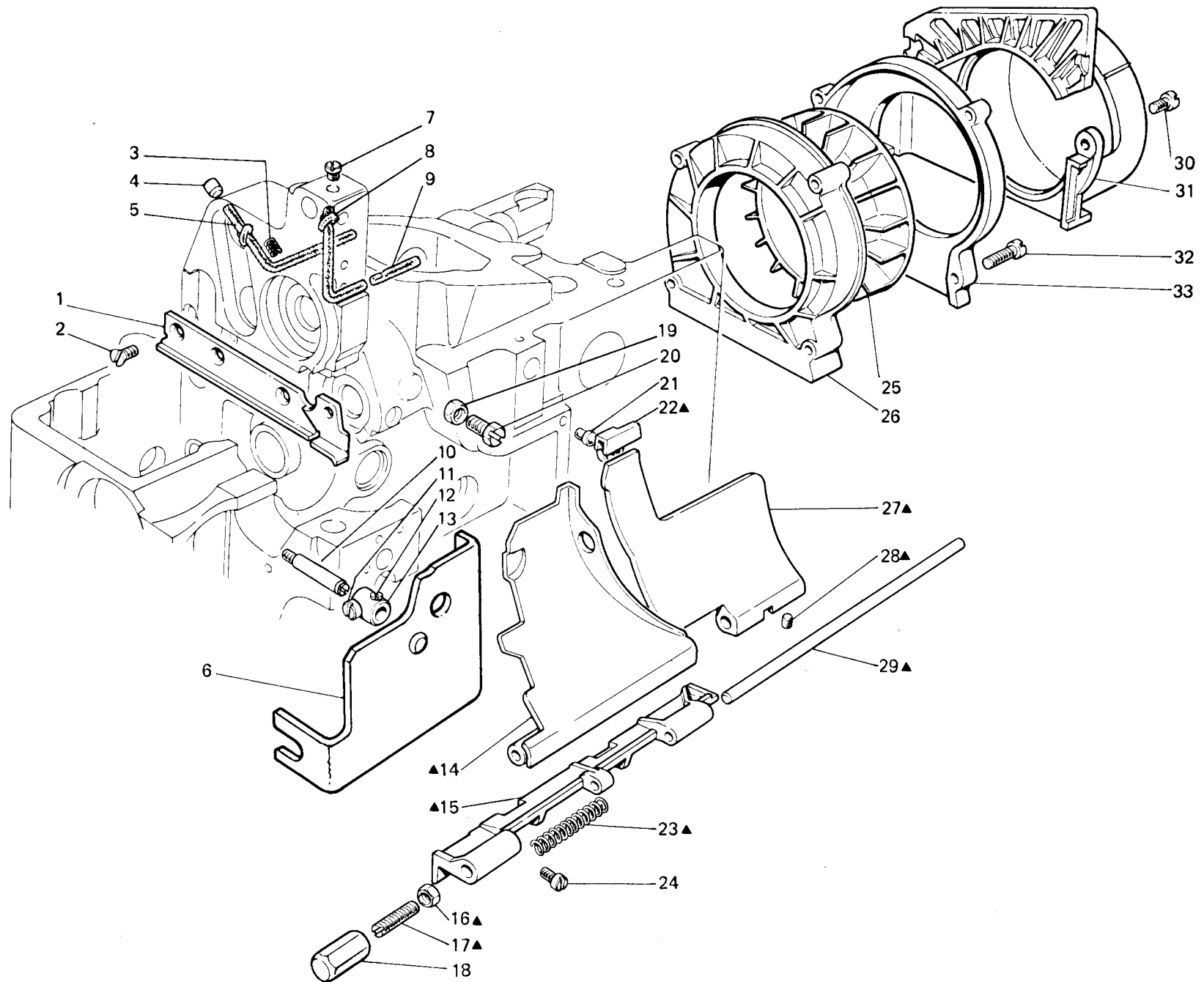

Fig. N. Abb. N.	Part. N. Bestell N. Piese N. Pieza N.	Qt. Anzahl	DESCRIZIONE	DESCRIPTION	DESCRIPTION	BENENNUNG	DESCRIPCION
▲	208060-4-00	1	sportello anteriore completo	front cover assembly	carter avant complet		
1	207961-0-00	1	carterino	cover	carter		
2	744634-2-00	3	vite	screw	vis		
3	208164-0-00	1	molla	spring	ressort		
4	301608-0-00	1	tappo	plug	bouchon		
5	778832-0-00	1	stoppino	wick	mèche		
6	208031-2-00	1	carter laterale	side cover	carter latéral		
7	742838-2-00	1	vite	screw	vis		
8	778833-0-00	1	stoppino	wick	mèche		
9	778417-0-00	1	stoppino	wick	mèche		
10	207069-0-01	1	vite per carter laterale	screw	vis		
11	721435-2-00	1	vite	screw	vis		
12	730023-2-00	1	vite	screw	vis		
13	206734-2-00	1	morsetto con viti	clamp with screw	collier de serrage avec vis		
14	208080-2-00	1	sportello scorrevole	sliding cover	carter coulissant		
15	206756-0-01	1	cerniera	hinge	charnière		
16	746208-2-00	1	dado	nut	écrou		
17	206769-0-10	1	vite di regolazione	adjustment screw	vis de réglage		
18	207071-0-00	1	cappuccio	cap	capuchon		
19	746007-2-00	1	dado	nut	écrou		
20	202214-0-11	1	vite	screw	vis		
21	207856-0-00	1	gommino	dumper	caoutchouc		
22	206764-0-00	1	zoccolo	block	socle		
23	206768-0-00	1	molla	spring	ressort		
24	741724-0-00	4	vite	screw	vis		
25	206690-2-00	1	ventola di raffreddamento	cooling fan	ventilateur		
26	206688-0-00	1	coclea per ventola	scroll	palier		
27	207858-0-00	1	sportello ribaltabile	tipping cover	carter amovible		
28	745800-2-00	1	vite	screw	vis		
29	206767-0-00	1	perno	pin	pivot		
30	722063-2-00	1	vite per coperchio	screw	vis		
31	207426-0-01	1	coperchio cinghia	cover	couvercle		
32	202484-0-10	4	vite	screw	vis		
33	206687-2-00	1	coperchio coclea	scroll cover	couvercle palier		

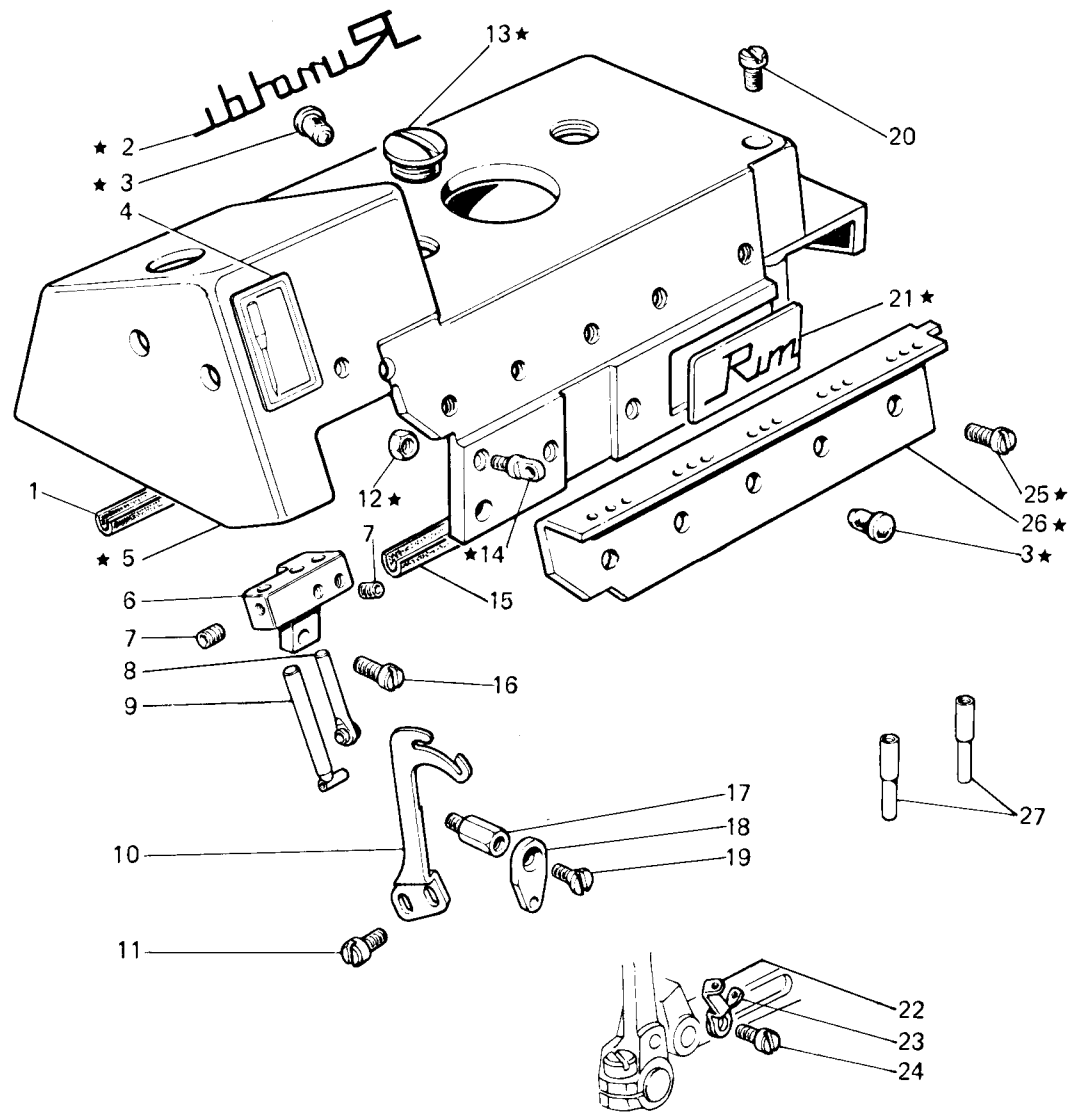

Fig. N. Abb. N.	Part. N. Piecce N. Bestell N. Preza N.	Qt. Anzahl	DESCRIZIONE	DESCRIPTION	DESCRIPTION	BENENNUNG	DESCRIPCION
★	208119-4-00	1	coperchio superiore completo	upper cover assembly		couvercle supérieur complet	
1	208091-0-00	1	guarnizione	gasket		garniture	
2	100305-0-10	1	decalcomania	decalcomania		décalcomanie	
3	207893-0-00	5	tappo	plug		bouchon	
4	788001-0-01	1	decalcomania sist. aghi	needles syst. decalcomania		décalcomanie syst. aiguilles	
5	207912-0-00	1	coperchio superiore	upper cover		couvercle supérieur	
6	207916-0-00	1	supporto passafili aghi	needles thread guide support		support passe-fil aiguilles	
7	745800-2-00	2	vite	screw		vis	
8	208184-2-00	1	passafilo	thread guide		passe-fil	
9	202267-2-13	1	passafilo	thread guide		passe-fil	
10	207895-0-00	1	tendifilo	thread take-up		tendeur du fil	
11	741558-0-00	2	vite	screw		vis	
12	733503-0-00	3	dado	nut		écrou	
13	207968-0-01	1	tappo	plug		bouchon	
14	206711-0-00	3	passafilo	thread guide		passe-fil	
15	208090-0-00	1	guarnizione	gasket		garniture	
16	741956-2-00	2	vite	screw		vis	
17	206755-0-00	1	colonnina	column		colonne	
18	206812-0-00	1	passafilo crochet sup.	upper looper thread guide		passe-fil crochet sup.	
19	744631-2-00	1	vite	screw		vis	
20	721484-2-00	3	vite fissa coperchio sup.	screw		vis	
21	208089-0-00	1	targhetta	plate		plaque	
22	202281-0-10	1	tendifilo crochet sup.	upper looper thread take-up		tendeur du fil crochet sup.	
23	202279-0-10	1	tendifilo crochet inf.	lower looper thread take-up		tendeur du fil crochet inf.	
24	741675-0-00	1	vite	screw		vis	
25	202397-0-10	2	vite	screw		vis	
26	208057-0-00	1	piastra passafili	plate		plaque	
27	206740-0-00	2	tubetto passafilo	thread guide pipe		tube passe-fil	
			SOLO A RICHIESTA	ONLY ON REQUEST		SEULEMENT SUR DEMANDE	
—	208310-4-00	1	gruppo passafili	thread guide assembly		groupe passe-fil	
8	208179-2-00	1	passafilo	thread guide		passe-fil	
9	208196-3-00	1	passafilo	thread guide		passe-fil	
12	733503-0-00	3	dado	nut		écrou	
14	208204-2-00	3	passafilo	thread guide		passe-fil	

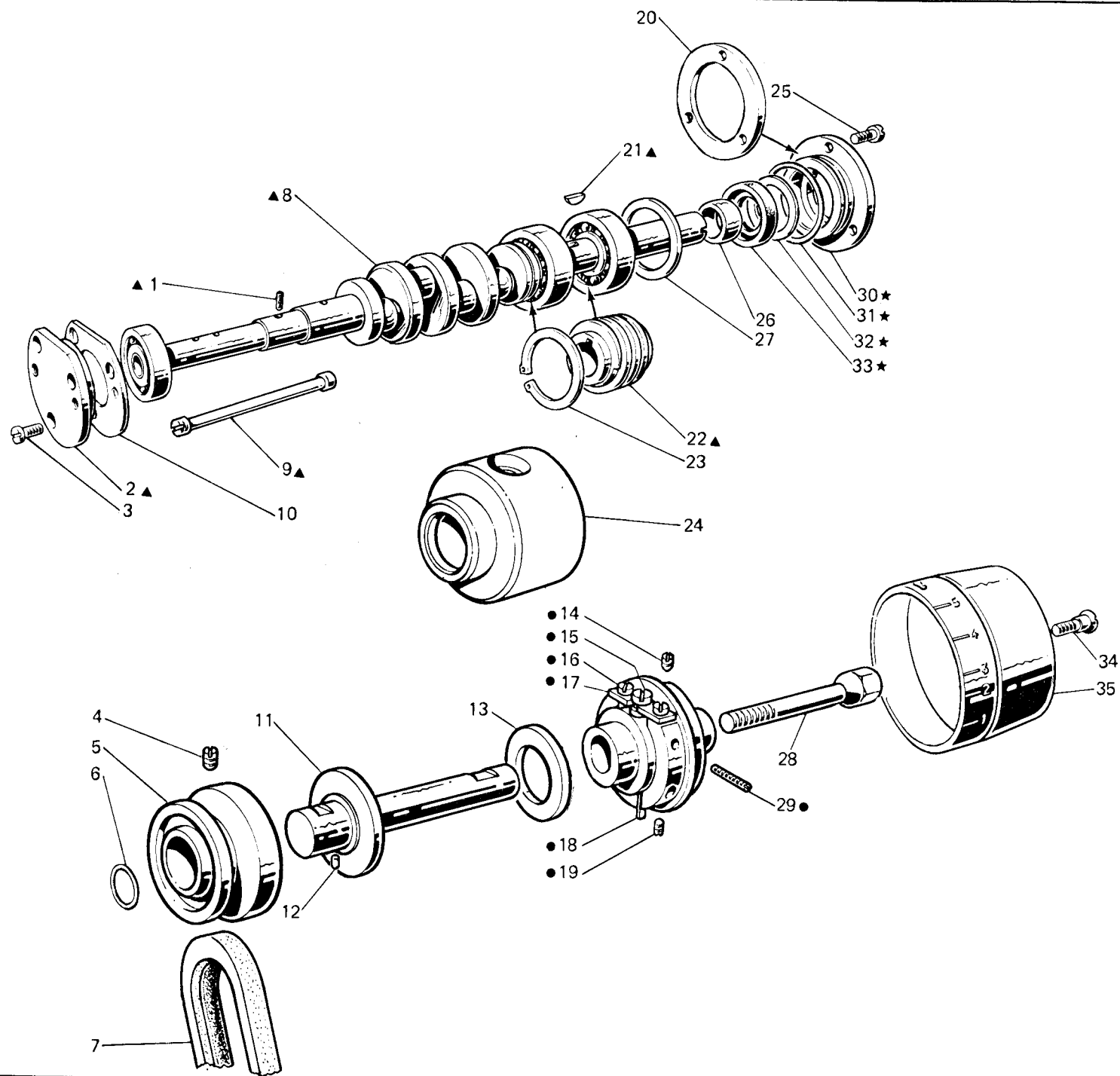

Fig. N. Abb. N.	Part. N. Bestell N. Piece N. Pieza N.	Qt. Anzahl	DESCRIZIONE	DESCRIPTION	DESCRIPTION	BENENNUNG	DESCRIPCION
●	207399-4-10	1	eccentrico reg. completo	eccentric assembly	excentrique compl.		
▲	206705-4-01	1	albero princ. con cuscinetti	main shaft with bearing	arbre princ. avec coussinet		
★	206697-4-01	1	gruppo flangia con anelli	flange with ring assembly	groupe flasque avec anneau		
1	206708-0-00	1	stoppino	wick	mèche		
2	206680-0-01	1	flangia sinistra	left flange	flasque gauche		
3	741956-2-00	3	vite	screw	vis		
4	729434-2-00	2	vite	screw	vis		
5	207087-2-00	1	volantino	handwheel	volant		
6	701116-0-00	1	anello di tenuta	retainer ring	bague d'étanchéité		
7	770031-0-00	1	cinghia	belt	courroie		
8	206702-2-01	1	albero principale	main shaft	arbre principal		
9	206974-0-00	1	limitatore olio	oil limiter	limiteur huile		
10	206543-0-01	1	guarnizione	gasket	garniture		
11	207402-2-00	1	prolunga albero principale	main shaft extension	extension arbre principal		
12	207089-0-00	1	spina	pin	goupille		
13	207410-0-00	1	reggispinta	thrust bearing	butée		
14	745317-0-00	2	vite	screw	vis		
15	304412-0-10	1	vite	screw	vis		
16	741721-2-00	2	vite	screw	vis		
17	304413-0-10	1	piastrina	plate	plaque		
18	304451-0-10	1	lardone	gib	lardon		
19	304462-0-20	2	vite	screw	vis		
20	206544-0-00	1	guarnizione	gasket	garniture		
21	204122-0-10	1	chiavetta	key	clavette		
22	206556-0-01	1	vite senza fine	worm screw	vis sans fin		
23	202386-0-10	1	anello elastico	spring ring	anneau ressort		
24	206682-0-01	1	bussola	bush	bague		
25	722063-2-00	3	vite	screw	vis		
26	206692-0-00	1	distanziale albero princ.	spacer	entretoise		
27	206689-0-01	1	anello compensazione	ring	anneau		
28	207097-0-02	1	vite	screw	vis		
29	730061-2-00	2	vite	screw	vis		
30	206699-0-01	1	flangia	flange	flasque		
31	701133-0-00	1	anello di tenuta	retainer ring	bague d'étanchéité		
32	206693-0-00	1	rondella	washer	rondelle		
33	700630-0-00	1	anello di tenuta	retainer ring	bague d'étanchéité		
34	202492-0-10	1	vite	screw	vis		
35	206679-0-00	1	coperchio volante	handwheel cover	couvercle volant		

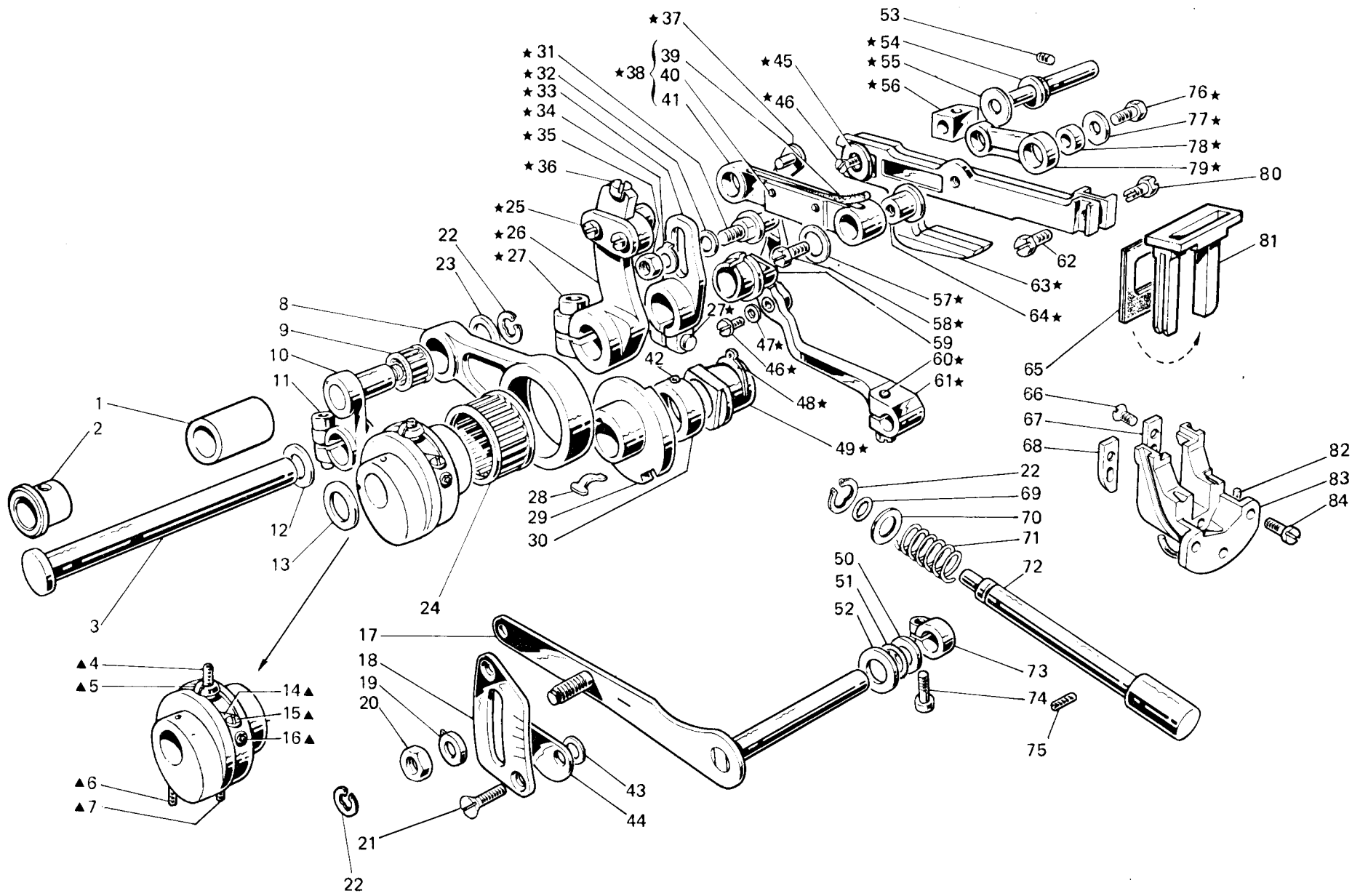

Fig. N. Abb. N.	Part. N. Bestell N. Pieca N. Pieza N.	Qt. Anzahl	DESCRIZIONE	DESCRIPTION	DESCRIPTION	BENENNUNG	DESCRIPCION
★	208097-4-00	1	gruppo comando slitta	slide control assembly		groupe commande glissière	
▲	207950-4-00	1	gruppo eccentr. regol. trasporto	eccentric group		groupe excentrique	
1	206594-0-00	1	bussola	bush		bage	
2	206595-0-00	1	bussola	bush		bage	
3	206593-0-00	1	contralbero trasporto	transport countershaft		axe transport	
4	729051-2-00	1	vite	screw		vis	
5	206603-0-10	1	fermo eccentrico	eccentric retainer		pièce blocage excentrique	
6	745815-2-00	1	vite	screw		vis	
7	727884-0-00	1	vite	screw		vis	
8	206599-0-01	1	biella comando trasporto	transport con-rod		bielle commande transport	
9	201358-0-10	1	gabbia a rullini	needles cage		cage à aiguilles	
10	206598-3-00	1	braccio a manov. con vite	crank arm with screw		bras à manivelle avec vis	
11	744334-2-00	1	vite	screw		vis	
12	704841-0-00	1	rondella	washer		rondelle	
13	206602-0-00	1	rondella	washer		rondelle	
14	202412-0-11	1	lardoné	gib		lardon	
15	202473-0-11	2	vite	screw		vis	
16	730011-2-00	2	vite	screw		vis	
17	202345-2-31	1	leva	lever		levier	
18	207060-0-00	1	settore di regolazione	sector		secteur	
19	704009-4-00	1	rondella	washer		rondelle	
20	202474-0-10	1	dado	nut		écrou	
21	724895-2-00	2	vite	screw		vis	
22	700207-0-00	3	anello elastico	spring ring		anneau ressort	
23	206546-0-00	1	rondella	washer		rondelle	
24	202385-0-10	1	gabbia a rullini	needles cage		cage à aiguilles	
25	741546-2-00	2	vite	screw		vis	
26	206592-3-00	1	manovella trasp. con viti	transport crank with screw		manivelle transport avec vis	
27	744332-2-00	2	vite	screw		vis	
28	206872-0-00	1	molla	spring		ressort	
29	206605-0-01	1	eccentrico	eccentric		excentrique	
30	206606-2-00	1	anello di rasamento	shim		bage	
31	202063-0-10	1	spina	pin		goupille	
32	704808-0-00	1	rondella	washer		rondelle	
33	206584-2-00	1	braccio manovella	crank arm		bras manivelle	
34	206580-2-00	1	rondella con spina	washer with pin		rondelle avec goupille	
35	746008-0-00	1	dado	nut		écrou	
36	741413-0-00	1	vite	screw		vis	
37	207724-2-00	1	giunto	joint		joint	
38	206615-4-00	1	biellino completo	con-rod assembly		petite-bielle complète	
39	778417-0-00	1	stoppino	wick		mèche	
40	200490-0-00	2	spillo	needle		épingle	
41	206587-0-01	1	biellino	con-rod		petite-bielle	
42	745812-2-00	2	vite	screw		vis	
43	704308-4-00	2	rondella	washer		rondelle	
44	202292-0-10	2	settore	sector		secteur	
45	202475-0-10	1	rondella	washer		rondelle	
46	724032-0-00	2	vite	screw		vis	
47	207719-0-00	1	rondella	washer		rondelle	

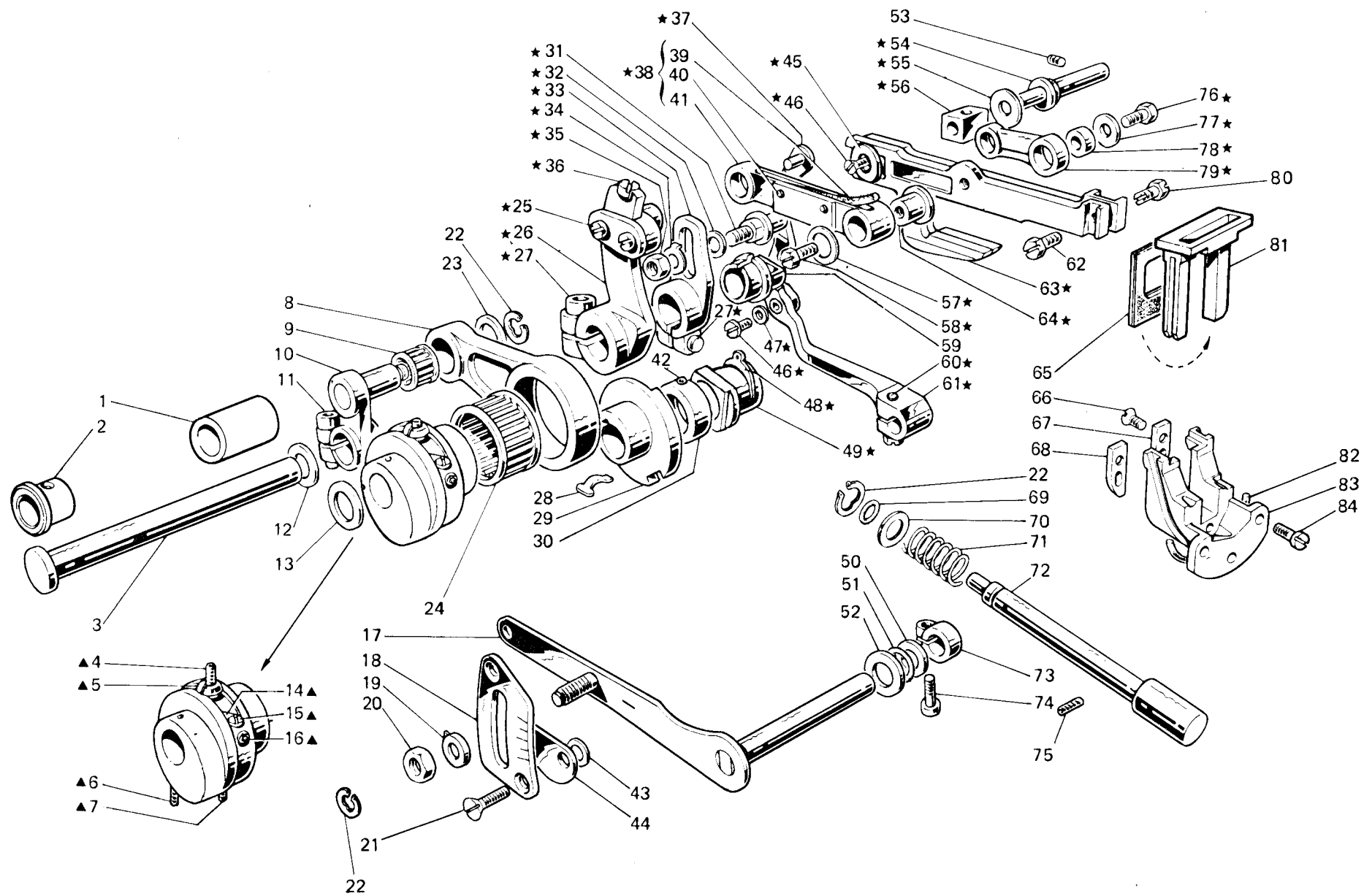

Fig. N. Abb. N.	Part. N. Piecce N. Bestell N. Pieza N.	Qt. Anzahl	DESCRIZIONE	DESCRIPTION	DESCRIPTION	BENENNUNG	DESCRIPCION
48	201610-0-01	1	anello elastico	spring ring	anneau ressort		
49	206617-0-00	1	blocchetto	block	bloc		
50	704829-0-00	1	rondella	washer	rondelle		
51	701007-0-00	1	anello di tenuta	retainer ring	bague d'étanchéité		
52	705230-0-00	1	rondella	washer	rondelle		
53	202478-0-10	1	vite	screw	vis		
54	206613-0-00	1	perno eccentrico	eccentric pin	pivot excentrique		
55	705408-0-00	1	rondella	washer	rondelle		
56	202033-0-10	1	blocchetto	block	bloc		
57	705008-0-00	1	rondella	washer	rondelle		
58	206588-0-00	1	vite	screw	vis		
59	206619-0-00	1	vaschetta olio	oil sump	cuvette huile		
60	740053-2-00	1	vite	screw	vis		
61	207711-2-10	1	braccio reg. differenz.	differential arm	bras regl. différentiel		
62	202489-0-10	1	vite	screw	vis		
63	207942-3-00	1	gruppo slitta	slide assembly	groupe glissière		
64	206586-0-01	1	bussola per biellino	bush	bague		
65	207944-0-00	2	guarnizione raschia olio	gasket	garniture		
66	744512-4-00	2	vite	screw	vis		
67	207947-0-00	1	piastrina	plate	plaque		
68	207945-0-00	1	piastrina	plate	plaque		
69	701004-0-00	1	anello	ring	anneau		
70	704314-2-00	1	rondella	washer	rondelle		
71	202408-0-10	1	molla	spring	ressort		
72	206618-0-10	1	pulsante reg. punto	push-button	poussoir		
73	100620-2-10	1	morsetto con vite	clamp with screw	collier de serrage avec vis		
74	741745-2-00	1	vite	screw	vis		
75	729032-2-00	1	vite	screw	vis		
76	202490-0-10	1	vite	screw	vis		
77	705208-0-00	1	rondella	washer	rondelle		
78	202032-0-11	1	bussolina	bush	bague		
79	206583-0-00	1	biellino	con-rod	petite bielle		
80	202488-0-10	1	vite	screw	vis		
81	207946-0-01	1	telaio raschia olio	oil scraper frame	râcheur huile		
82	207948-0-00	1	guarnizione	gasket	garniture		
83	207943-2-00	1	guida slitta	slide guide	guide coulissant		
84	722063-2-00	3	vite	screw	vis		

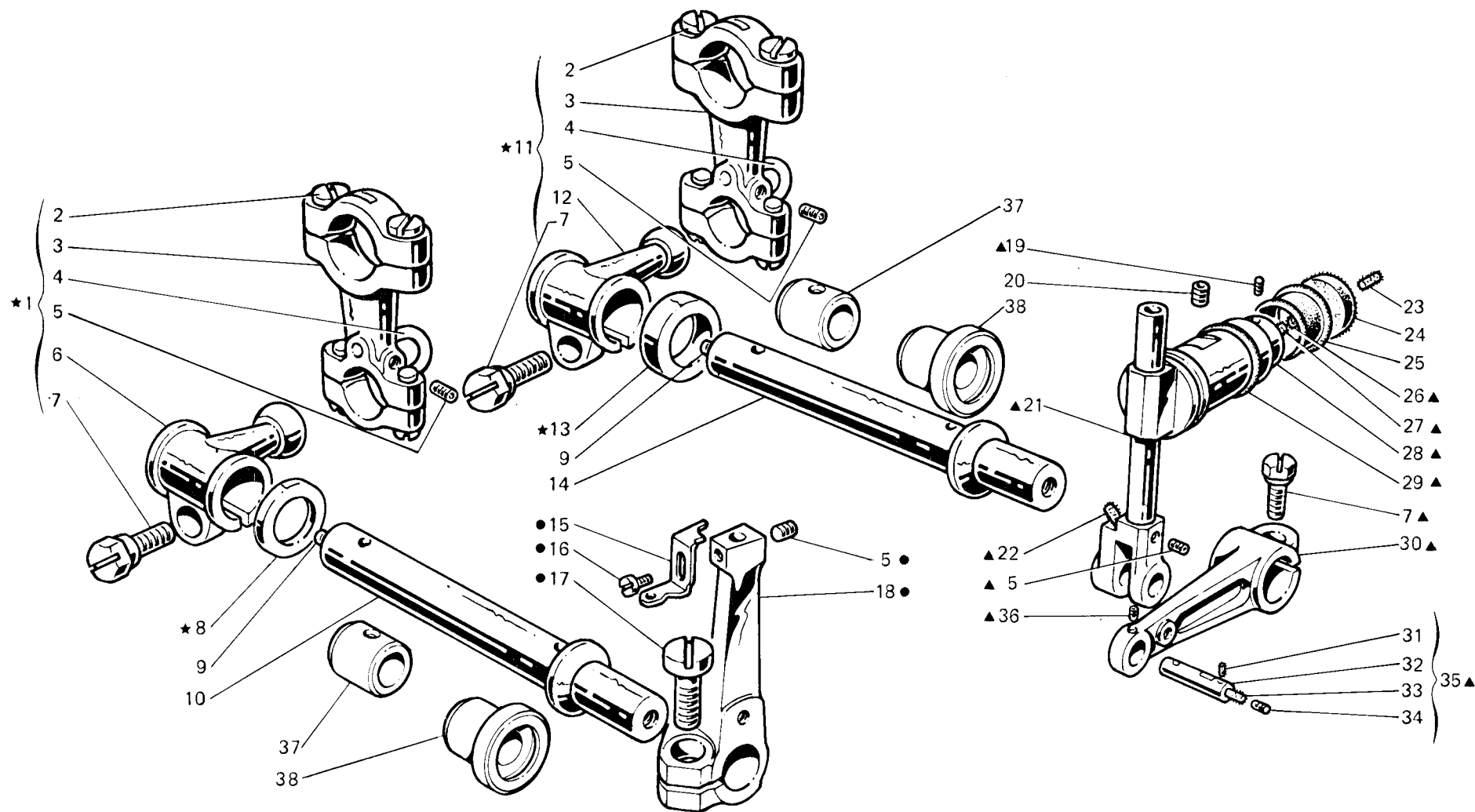

Fig. N. Abb. N.	Part. N. Bestell N. Pieça N. Pieza N.	Qt. Anzahl	DESCRIZIONE	DESCRIPTION	DESCRIPTION	BENENNUNG	DESCRIPCION
★	206400-4-00	1	gruppo manicotti com. crochet	looper control coupling ass.	groupe manchon comm. crochet		
▲	206421-4-00	1	gruppo comando crochet sup.	upper looper control assembly	groupe comm. crochet supérieur		
●	208039-4-00	1	gruppo porta crochet inferiore	lower looper assembly	groupe porte crochet inférieur		
1	206453-4-00	1	gruppo manicotto con biella	coupling assembly with con-rod	groupe manchon avec bielle		
2	743243-2-00	8	vite per biella	screw	vis		
3	202071-2-20	2	biella con viti	con-rod with screw	bielle avec vis		
4	206643-0-01	2	cavalotto	coupling	cavalier		
5	745812-2-00	4	vite	screw	vis		
6	206659-2-01	1	manicotto	coupling	manchon		
7	201128-0-10	3	vite	screw	vis		
8	704845-0-00	1	rondella	washer	rondelle		
9	206695-0-00	2	tappo per albero	plug for shaft	bouchon pour arbre		
10	207096-2-00	1	albero crochet inferiore	shaft lower looper	arbre crochet inférieur		
11	206452-4-00	1	gruppo manicotto con biella	coupling with con-rod	groupe manchon avec bielle		
12	206658-2-02	1	manicotto	coupling	manchon		
13	704848-0-00	1	rondella	washer	rondelle		
14	207095-2-00	1	albero crochet superiore	upper looper shaft	arbre crochet supérieur		
15	208015-0-00	1	squadretta	bracket	équerre		
16	741415-0-00	1	vite	screw	vis		
17	721883-0-00	1	vite	screw	vis		
18	206654-2-10	1	porta crochet inf.	lower looper holder	porte crochet inférieur		
19	745800-2-00	1	vite	screw	vis		
20	745168-0-00	1	vite	screw	vis		
21	206409-3-00	1	guida oscillante	oscillating guide	guide oscillant		
22	778403-0-00	1	stoppino	wick	mèche		
23	778236-0-00	1	stoppino	wick	mèche		
24	206686-0-00	1	disco lubrificazione guida	disc	disque		
25	202720-0-00	1	paraolio	oil retainer	pare-huile		
26	778405-0-00	1	stoppino	wick	mèche		
27	778410-0-00	1	stoppino	wick	mèche		
28	202062-2-10	1	anello con vite	ring with screw	anneau avec vis		
29	701113-0-00	1	anello di tenuta	circlip	circlip		
30	206653-2-01	1	braccio	arm	bras		
31	778202-0-00	4	stoppino	wick	mèche		
32	202086-0-11	1	spina	pin	goupille		
33	778401-0-00	1	stoppino	wick	mèche		
34	745002-0-00	1	vite	screw	vis		
35	206645-4-02	1	spina completa	pin assembly	goupille compl.		
36	745810-2-00	1	vite	screw	vis		
37	206651-0-00	2	bussola	bush	bague		
38	202065-0-20	2	bussola	bush	bague		

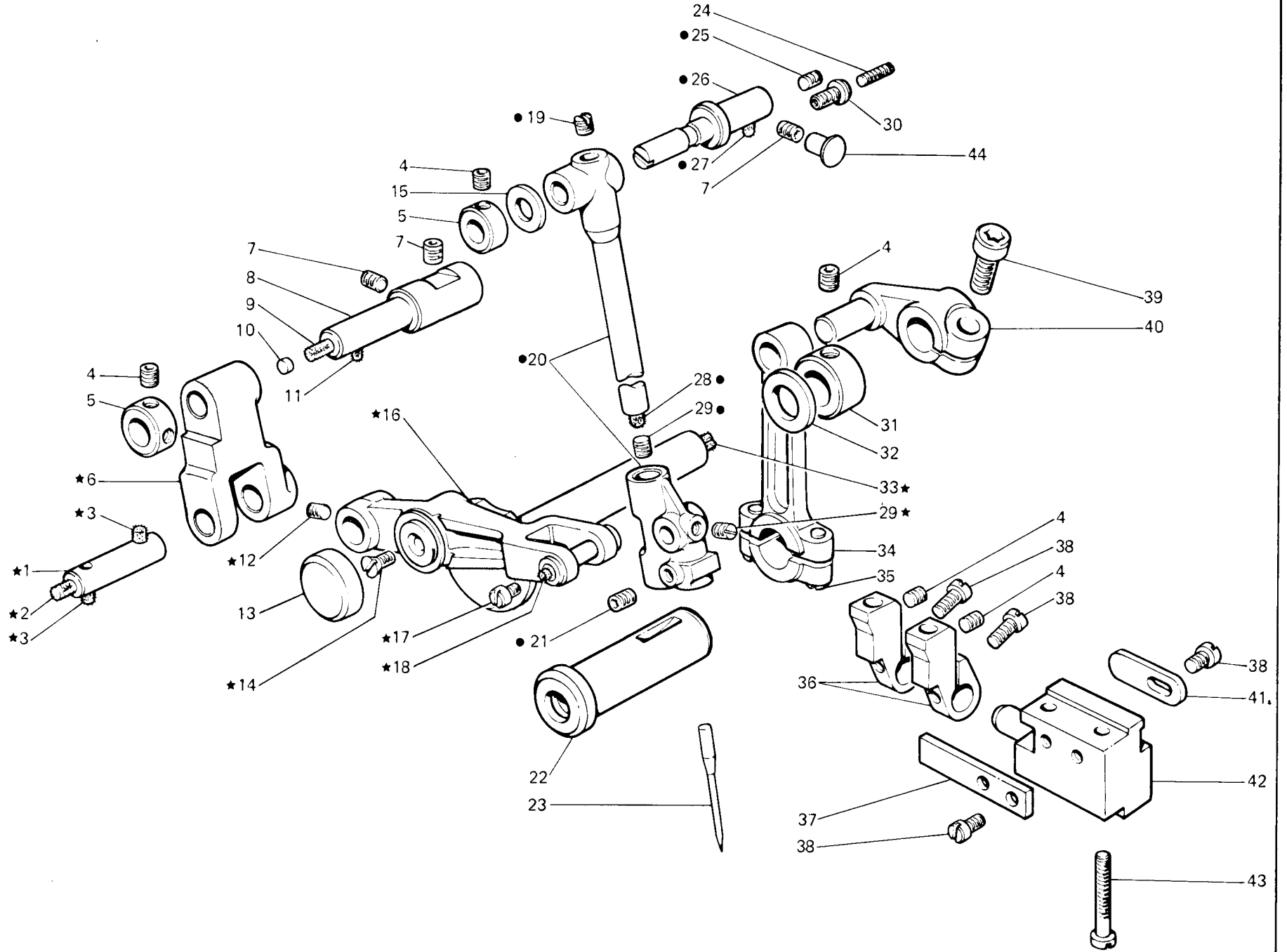

Fig. N. Abb. N.	Part. N. Piece N. Bestell N. Pieza N.	Qt. Anzahl	DESCRIZIONE	DESCRIPTION	DESCRIPTION	BENENNUNG	DESCRIPCION
★	208140-4-10	1	cinematismo comando ago (con fig. ●)	needle control assembly (with fig. ●)	cinématisme comm. aiguille (avec fig. ●)		
●	208161-4-01	1	slitta con barra completa	slide with bar assembly	glissière avec barre complète		
1	207930-0-01	1	spina	pin	goupille		
2	778414-0-00	1	stoppino	wick	mèche		
3	778204-0-00	3	stoppino	wick	mèche		
4	745812-0-00	7	vite	screw	vis		
5	207692-2-00	2	anello di rasamento con viti	ring with screw	anneau avec vis		
6	207932-0-10	1	leva	lever	levier		
7	729034-2-00	3	vite	screw	vis		
8	208163-4-00	1	perno con stoppini e tappo	pin with wick and plug	pivot avec mèche et bouchon		
9	778417-0-00	1	stoppino	wick	mèche		
10	206521-0-00	1	tappo	plug	bouchon		
11	778511-0-00	2	stoppino	wick	mèche		
12	745114-0-00	1	vite	screw	vis		
13	206533-0-00	1	coperchio per leva	cover for lever	couvercle pour levier		
14	724032-0-00	1	vite	screw	vis		
15	309562-0-00	1	rondella	washer	rondelle		
16	208142-3-01	1	gruppo leva con spina	lever with pin assembly	groupe levier avec goupille		
17	741405-0-00	1	vite	screw	vis		
18	778208-0-00	1	stoppino	wick	mèche		
19	310167-0-00	1	vite	screw	vis		
20	207922-3-10	1	slitta con barra	slide with bar	glissière avec barre		
21	729012-2-00	1	vite	screw	vis		
22	206538-0-00	1	bussola	bush	bague		
23	765200-6-80	1	ago RIM 27 fin. 80	needle RIM 27 size 80	aiguille RIM 27 jauge 80		
24	729051-2-00	1	vite	screw	vis		
25	727014-2-00	1	vite	screw	vis		
26	207927-0-01	1	perno	pin	pivot		
27	778419-0-00	1	stoppino	wick	mèche		
28	778503-0-00	1	stoppino	wick	mèche		
29	745002-0-00	2	vite	screw	vis		
30	206603-0-10	1	vite di fermo	screw	vis		
31	206606-2-00	1	anello di rasamento con vite	ring	anneau		
32	705029-0-00	1	rondella	washer	rondelle		
33	778837-0-00	1	stoppino	wick	mèche		
34	206549-2-00	1	biella con viti	con-rod with screw	bielle avec vis		
35	743471-2-00	2	vite	screw	vis		
36	207998-2-00	2	porta salva ago e spingi asola	front and rear needle guard holder	porte protège-aiguille et pare-boucle		
37	207991-0-00	1	piastrina	plate	plaque		
38	741552-0-00	5	vite	screw	vis		
39	744334-2-00	1	vite	screw	vis		
40	206540-2-00	1	manovella alb. sup. con vite	crank	manivelle		
41	207999-0-00	1	piastrina	plate	plaque		
42	207990-0-00	1	supporto salva ago	rear needle guard support	support protège-aiguille		
43	722480-2-00	2	vite	screw	vis		
44	207574-0-00	1	tappo	plug	bouchon		

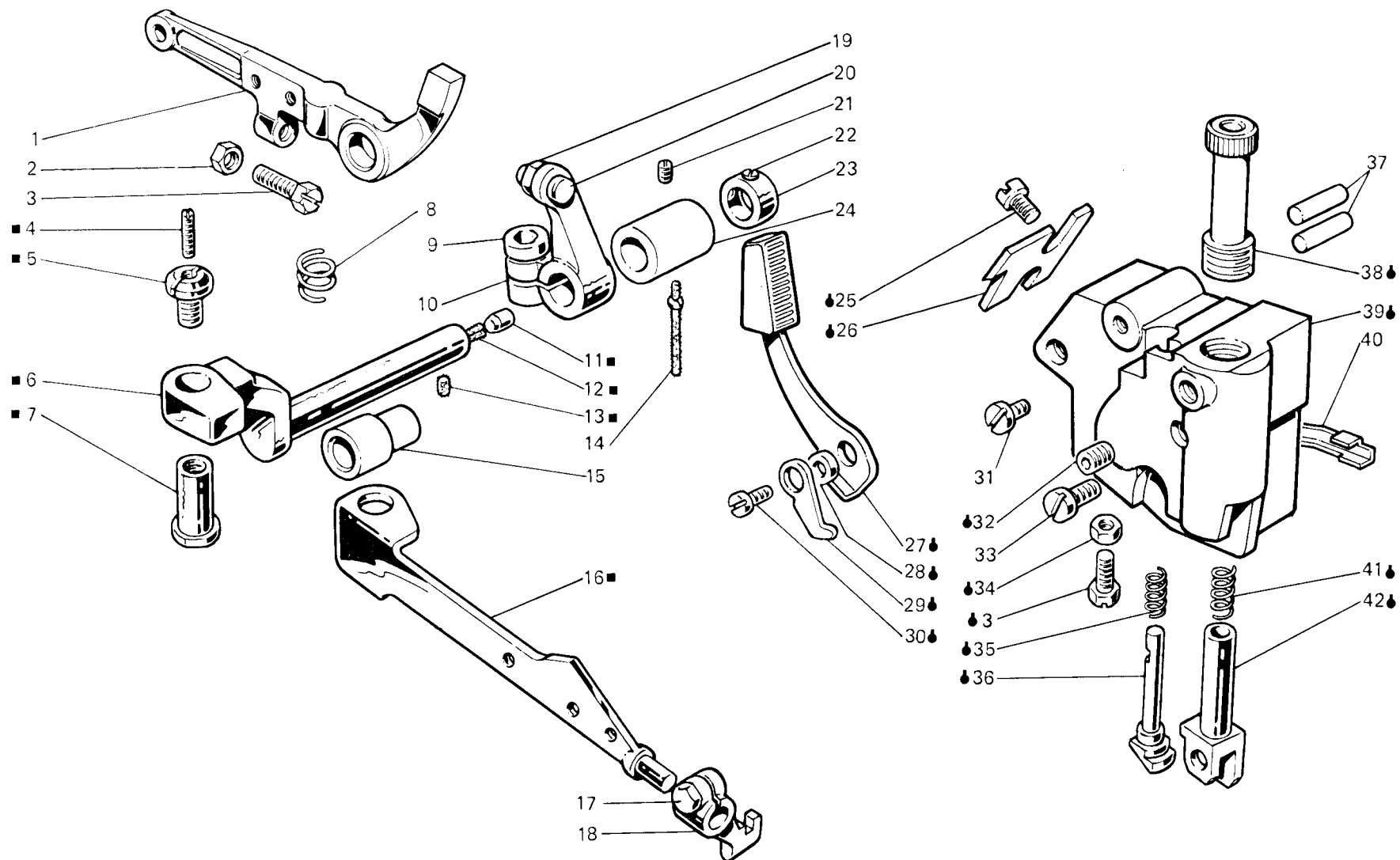

Fig. N. Abb. N.	Part. N. Bestell N. Piese N. Pieza N.	Qt. Anzahl	DESCRIZIONE	DESCRIPTION	DESCRIPTION	BENENNUNG	DESCRIPCION
☐	208135-4-00	1	gruppo supporto premistoffa	presser support assembly	groupe support pied-presseur		
■	207887-4-00	1	leva premistoffa con perno	presser lever	levier du pied-presseur		
1	207881-2-00	1	leva alza premistoffa	lever	levier		
2	733505-2-00	1	dado	nut	écrou		
3	202214-0-11	2	vite	screw	vis		
4	729051-2-00	1	vite	screw	vis		
5	202529-0-10	1	perno di fermo	pin	pivot		
6	207878-3-00	1	perno con tappo e stoppini	pin with plug and wicks	pivot avec bouchon et mèches		
7	206622-0-00	1	spina	pin	goupille		
8	206621-0-00	1	molla richiamo leva alza premist.	spring	ressort		
9	744332-2-00	1	vite	screw	vis		
10	207876-2-00	1	leva arresto premist. con viti	lever	levier		
11	301586-0-10	1	pastiglia	plug	bouchon		
12	778522-0-00	1	stoppino	wick	mèche		
13	778204-0-00	1	stoppino	wick	mèche		
14	206620-0-00	1	stoppino	wick	mèche		
15	207880-0-00	1	bussola	bush	bague		
16	206808-0-01	1	leva	lever	levier		
17	204947-0-10	1	vite	screw	vis		
18	206810-2-00	1	attacco a morsetto premist.	coupling	raccord		
19	746020-2-00	1	dado	nut	écrou		
20	727096-0-00	1	vite	screw	vis		
21	745812-2-00	1	vite	screw	vis		
22	745114-0-00	2	vite	screw	vis		
23	207882-2-00	1	anello con viti	ring	anneau		
24	207879-0-00	1	bussola	bush	bague		
25	721434-2-00	2	vite	screw	vis		
26	207965-0-00	1	arresto	stopping	butée		
27	208133-2-00	1	leva	lever	levier		
28	206637-0-00	1	distanziale	spacer	entretoise		
29	206635-0-00	1	nasello	snug	déclit		
30	722063-2-00	1	vite	screw	vis		
31	722123-2-00	1	vite	screw	vis		
32	202391-0-11	1	vite	screw	vis		
33	206642-0-00	1	vite	screw	vis		
34	746007-2-00	1	dado	nut	écrou		
35	202110-0-10	1	molla	spring	ressort		
36	207959-0-00	1	tirante	tie-rod	tirant		
37	202371-0-10	2	spina	pin	goupille		
38	207967-0-00	1	vite	screw	vis		
39	207960-0-00	1	supporto	support	support		
40	207962-0-00	1	guarnizione	gasket	garniture		
41	203142-0-10	1	molla	spring	ressort		
42	206632-2-00	1	cannotto	column	fourche		

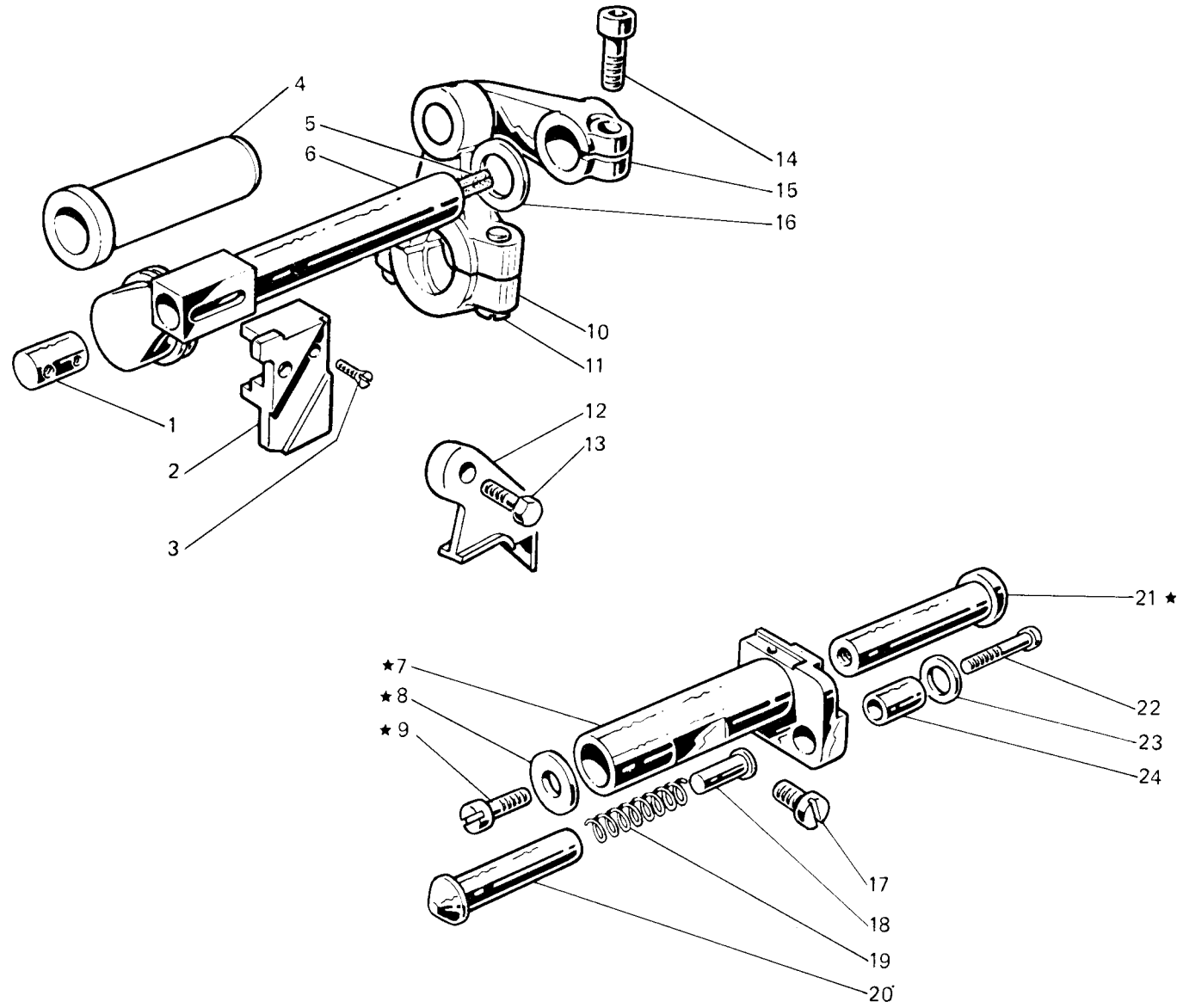

Fig. N. Abb. N.	Part. N. Bestell N. Piece N. Pieza N.	Qt. Anzahl	DESCRIZIONE	DESCRIPTION	DESCRIPTION	BENENNUNG	DESCRIPCION
★	202133-4-10	1	porta coltello inferiore compl.	lower knife holder assembly	porte couteau inférieur compl.		
1	202130-0-11	1	perno	pin	pivot		
2	207588-0-00	1	placchetta	plate	plaque		
3	744533-0-00	1	vite	screw	vis		
4	206539-0-00	1	bussola	bush	bage		
5	778835-0-00	1	stoppino	wick	mèche		
6	207861-4-00	1	albero colt. sup. con stoppino	shaft	arbre		
7	202132-0-10	1	porta coltello inferiore	lower knife holding	porte couteau inférieur		
8	704409-0-00	1	rondella	washer	rondelle		
9	742457-2-00	1	vite	screw	vis		
10	206578-2-00	1	biella con viti	con-rod with screw	bielle avec vis		
11	743471-2-00	2	vite	screw	vis		
12	207589-0-00	1	staffa	bracket	équerre		
13	207421-0-00	1	vite	screw	vis		
14	744334-2-00	1	vite	screw	vis		
15	206574-2-00	1	manovella alb. coltello sup.	crank for upper knife shaft	manivelle arbre couteau sup.		
16	705029-0-00	1	rondella	washer	rondelle		
17	742758-0-00	1	vite	screw	vis		
18	206758-0-10	1	puntalino	pin	pivot		
19	202128-0-10	1	molla	spring	ressort		
20	206757-0-00	1	bussola	bush	bage		
21	202134-0-11	1	perno	pin	pivot		
22	722471-2-00	1	vite	screw	vis		
23	704406-0-00	1	rondella	washer	rondelle		
24	202129-0-10	1	bussola	bush	bage		

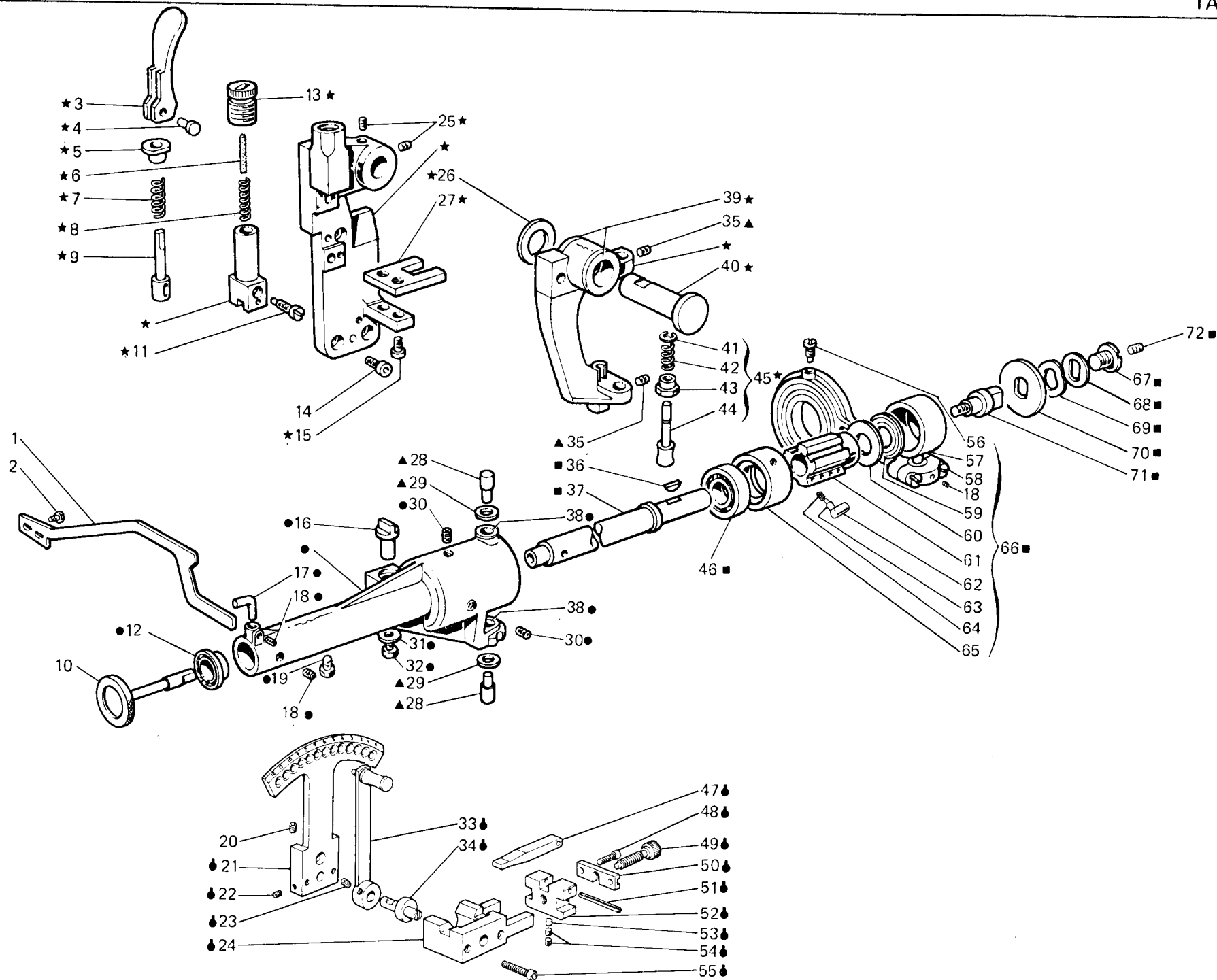

Fig. N. Abb. N.	Part. N. Bestell N. Pieca N. Pieza N.	Qt. Anzahl	DESCRIZIONE	DESCRIPTION	DESCRIPTION	BENENNUNG	DESCRIPCION
▲	207355-4-10	1	piastra con braccio compl. (con fig. ★●)	plate with arm assembly (with fig. ★●)	plaque avec bras compl. (avec fig. ★●)		
★	207356-4-02	1	piastra supporto compl.	support plate assembly	plaque support compl.		
●	207370-4-10	1	braccio completo (con fig. ■)	arm assembly (with fig. ■)	bras complet (avec fig. ■)		
■	207380-4-10	1	albero completo	shaft assembly	arbre complet		
◆	942930-4-00	1	dispositivo completo	device assembly	dispositif complet		
1	208059-0-00	1	leva	lever	levier		
2	720431-2-00	2	vite	screw	vis		
3	204608-0-10	1	leva	lever	levier		
4	207408-0-00	1	perno	pin	pivot		
5	202112-0-10	1	bussola	bush	bague		
6	778415-0-00	1	stoppino	wick	mèche		
7	202110-0-10	1	molla	spring	ressort		
8	205021-0-10	1	molla	spring	ressort		
9	207362-0-00	1	perno	pin	pivot		
10	207431-0-01	1	rullino	roller	rouleau		
11	207377-0-00	1	vite	screw	vis		
12	207373-0-00	1	cuscinetto	bearing	coussinet		
13	207361-0-00	1	vite di regolazione	adjustment screw	vis de réglage		
14	722421-2-00	3	vite	screw	vis		
15	722432-2-00	2	vite	screw	vis		
16	207375-0-00	1	nasello	snug	déclic		
17	207406-0-00	1	gancio	hook	crochet		
18	745800-2-00	3	vite	screw	vis		
19	207389-0-00	1	vite	screw	vis		
20	729033-2-00	1	vite	screw	vis		
21	942931-2-00	1	settore con perno e viti	sector with pin and screw	secteur avec pivot et vis		
22	729011-2-00	2	vite	screw	vis		
23	729012-2-00	1	vite	screw	vis		
24	942938-0-00	1	supporto	support	support		
25	745815-2-00	2	vite	screw	vis		
26	705036-0-00	1	rondella	washer	rondelle		
27	207439-0-00	1	forcella guida	fork	fourche		
28	207405-0-00	2	spina	pin	goupille		
29	704805-0-00	2	rondella	washer	rondelle		
30	730022-2-00	3	vite	screw	vis		
31	704608-0-00	1	rondella	washer	rondelle		
32	722411-2-00	1	vite	screw	vis		
33	942934-2-00	1	leva con vite	lever with screw	levier avec vis		
34	942940-0-00	1	perno eccentrico 1	eccentric pin 1	pivot excentrique 1		
	942939-0-00	1	perno eccentrico 2 (in alternativa)	eccentric pin 2	pivot excentrique 2		
	942941-0-00	1	perno eccentrico 0,6 (in alternativa)	eccentric pin 0,6	pivot excentrique 0,6		
35	745812-2-00	2	vite	screw	vis		
36	204122-0-10	1	chiavetta	key	clavette		
37	207381-0-00	1	albero	shaft	arbre		
38	207374-0-00	2	bussola	bush	bague		
39	207367-0-00	2	bussola	bush	bague		
40	207363-2-00	1	perno	pin	pivot		
41	700206-0-00	1	anello elastico	spring ring	anneau ressort		

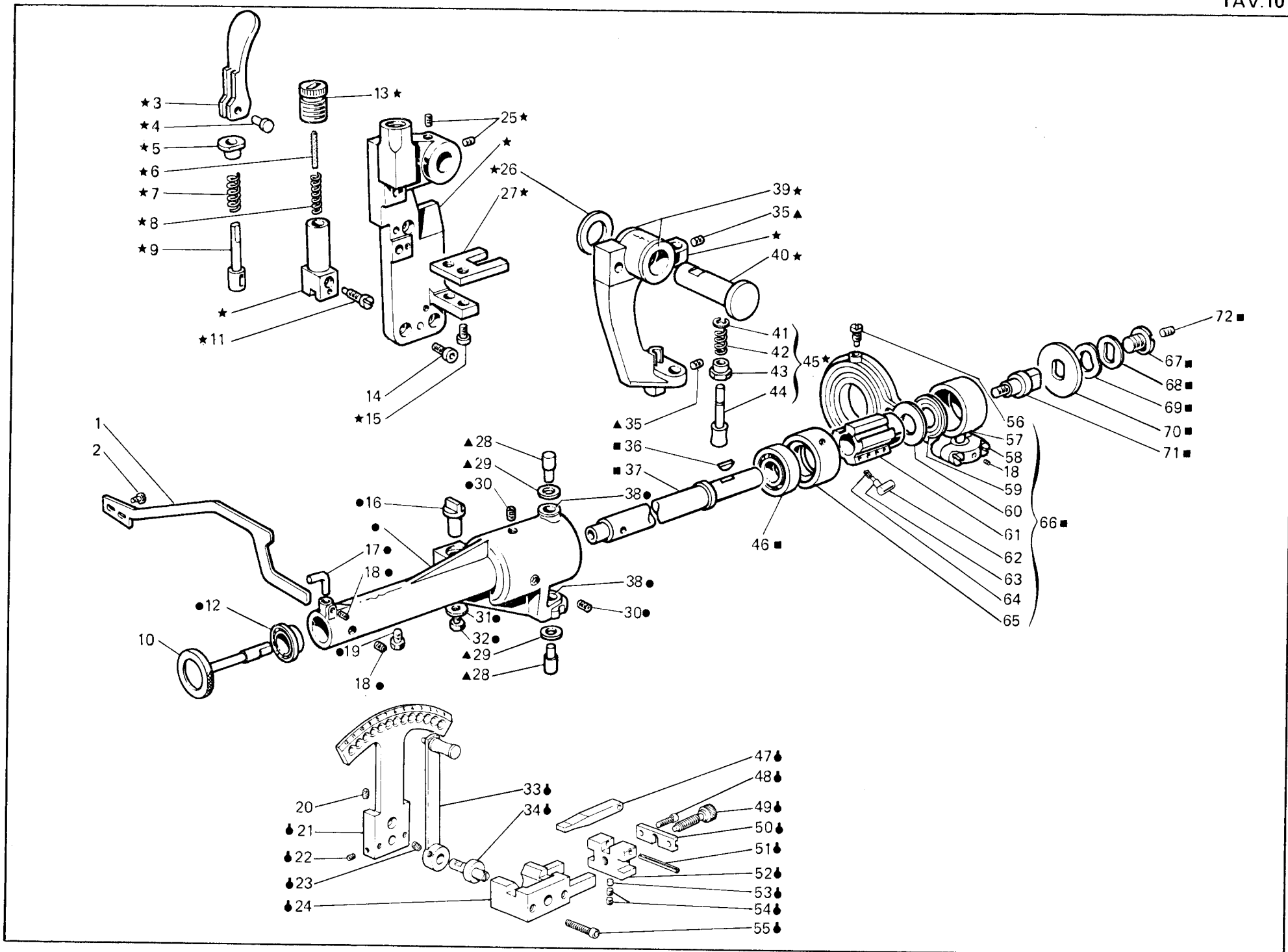

Fig. N. Abb. N.	Part. N. Bestell N. Piece N. Pieza N.	Qt. Anzahl	DESCRIZIONE	DESCRIPTION	DESCRIPTION	BENENNUNG	DESCRIPCION
42	207404-0-00	1	molla	spring	ressort		
43	207369-0-00	1	tappo	plug	bouchon		
44	207368-0-00	1	piolo	pin	pivot		
45	207364-4-00	1	piolo completo	pin assembly	pivot complet		
46	202389-0-10	1	cuscinetto	bearing	coussinet		
47	942942-0-00	1	cuneo	wedge	coin		
48	741546-2-00	2	vite	screw	vis		
49	942945-0-00	1	perno filettato	pin	pivot		
50	942944-0-00	1	piastrina	plate	plaque		
51	707300-0-00	1	spina elastica	split pin	pivot élastique		
52	942946-0-00	1	slitta	slide	glissière		
53	942943-0-00	1	pastiglia	plug	bouchon		
54	745810-2-00	2	vite	screw	vis		
55	722490-2-00	2	vite	screw	vis		
56	207394-0-00	1	vite	screw	vis		
57	207395-3-10	1	biella completa	con-rod assembly	bielle complète		
58	743243-2-00	2	vite	screw	vis		
59	207388-0-00	1	reggispinta	thrust	butée		
60	207387-0-00	1	rondella	washer	rondelle		
61	207383-0-00	1	settore	sector	secteur		
62	100891-0-10	20	rullino	roller	rouleau		
63	100892-0-10	20	spinetta	pin	goupille		
64	100893-0-10	20	molla	spring	ressort		
65	207384-0-00	1	manicotto	coupling	manchon		
66	207382-4-10	1	frizione completa	friction assembly	friction compl.		
67	207392-0-00	1	vite	screw	vis		
68	207391-0-01	1	rondella	washer	rondelle		
69	925448-0-00	1	rondella elastica	spring washer	rondelle élastique		
70	207390-0-00	1	freno	breakage	frein		
71	207379-0-00	1	terminale	terminal	extrémité		
72	729051-2-00	1	vite	screw	vis		

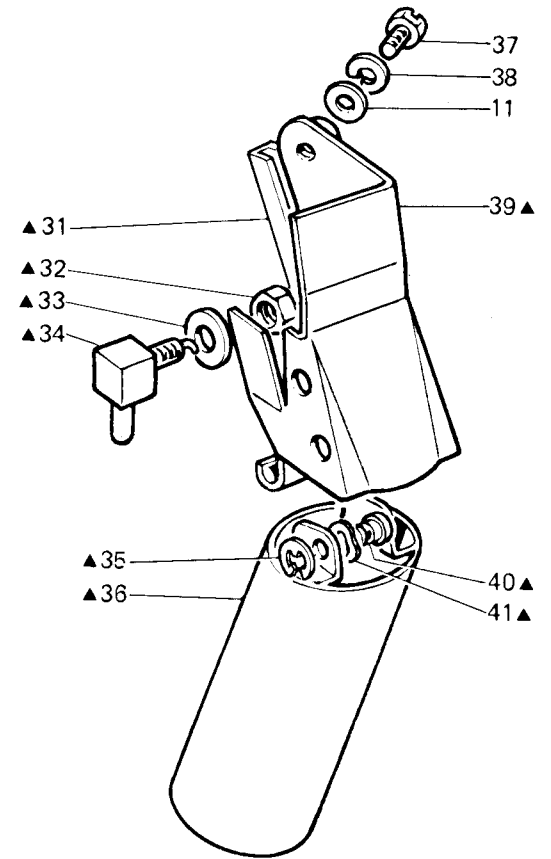
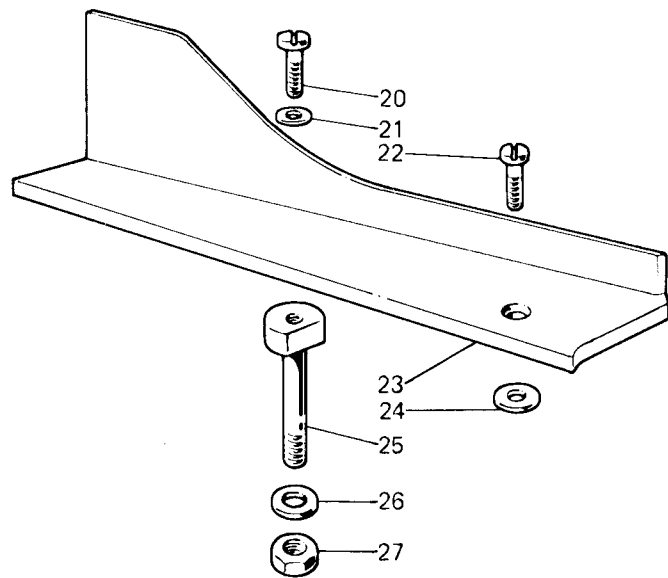
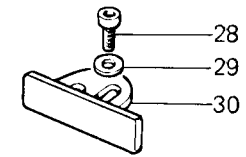
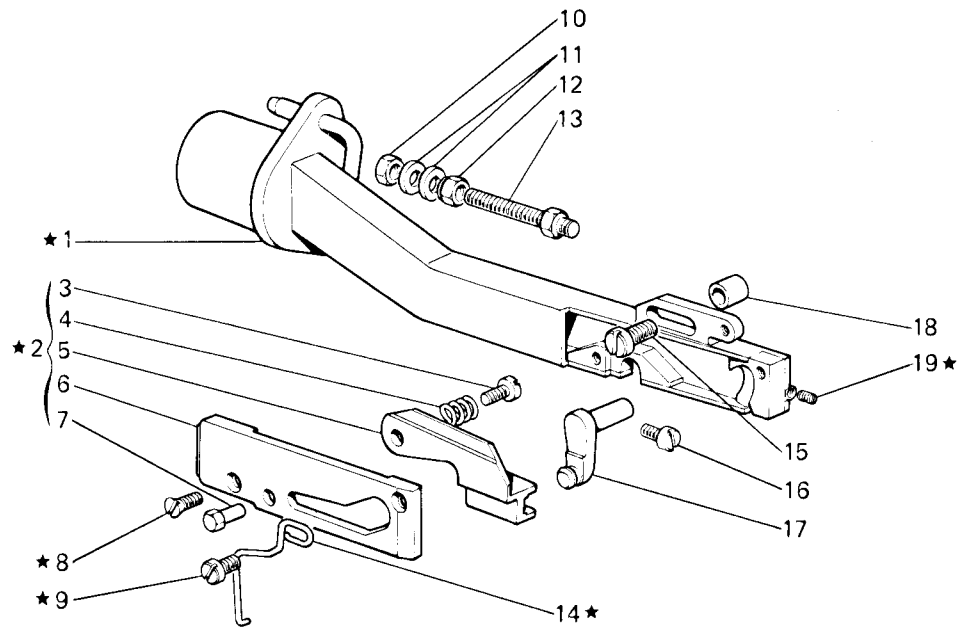

Fig. N. Abb. N.	Part. N. Bestell N. Piecze N. Pieza N.	Qt. Anzahl	DESCRIZIONE	DESCRIPTION	DESCRIPTION	BENENNUNG	DESCRIPCION
▲	944160-4-01	1	bocchetta aspira ritagli compl.	cuttings suction nozzle assembly	embouchure d'aspirat. déchets compl.		
★	923989-4-00	1	gruppo tubo aspiraz. catenella	suction pipe assembly	groupe tube aspiration		
1	923978-2-00	1	tubo aspirazione	suction pipe	tube aspirateur		
2	926755-4-01	1	gruppo coltelli	knives assembly	groupe couteaux		
3	926758-0-00	1	vite	screw	vis		
4	923918-0-01	1	molla	spring	ressort		
5	926754-2-01	1	coltello mobile	movable knife	couteau mobile		
6	926753-2-01	1	coltello fisso	immovable knife	couteau fixe		
7	923919-0-01	1	perno	pin	pivot		
8	744530-0-00	2	vite fissa coltelli	screw	vis		
9	721410-0-00	1	vite	screw	vis		
10	746021-2-00	1	dado	nut	écrou		
11	704310-2-00	3	rondella	washer	rondelle		
12	923943-0-00	1	dado	nut	écrou		
13	923942-0-00	1	perno filettato	pin	pivot		
14	923936-0-01	1	molla	spring	ressort		
15	741974-2-00	1	vite	screw	vis		
16	741931-0-00	1	vite	screw	vis		
17	923985-0-00	1	azionatore	actuator	activateur		
18	923994-0-00	1	distanziale	spacer	entretoise		
19	745001-0-00	1	vite	screw	vis		
20	741963-0-00	1	vite	screw	vis		
21	704306-0-00	1	rondella	washer	rondelle		
22	721483-0-00	1	vite	screw	vis		
23	943158-2-00	1	guida tessuto	fabric guide	guide tissu		
24	704218-2-00	1	rondella	washer	rondelle		
25	943159-0-00	1	perno filettato	pin	pivot		
26	704314-2-00	1	rondella	washer	rondelle		
27	733508-2-00	1	dado	nut	écrou		
28	722410-2-00	2	vite	screw	vis		
29	704104-2-00	2	rondella	washer	rondelle		
30	941047-0-01	1	squadretta	bracket	équerre		
31	927398-0-00	1	ammortizzatore	dampener	amortisseur		
32	746402-2-00	1	dado	nut	écrou		
33	704108-2-00	1	rondella	washer	rondelle		
34	944165-2-00	1	soffiatore	blower	souffleur		
35	700207-0-00	2	anello elastico	spring ring	anneau ressort		
36	944162-0-01	1	tubo scarica ritagli	pipe	tube		
37	740257-2-00	1	vite	screw	vis		
38	703007-0-00	1	rondella elastica	spring washer	rondelle élastique		
39	944161-2-01	1	bocchetta	cup	embouchure		
40	944164-0-00	2	perno	pin	pivot		
41	307605-0-00	2	anello di compensazione	ring	anneau		

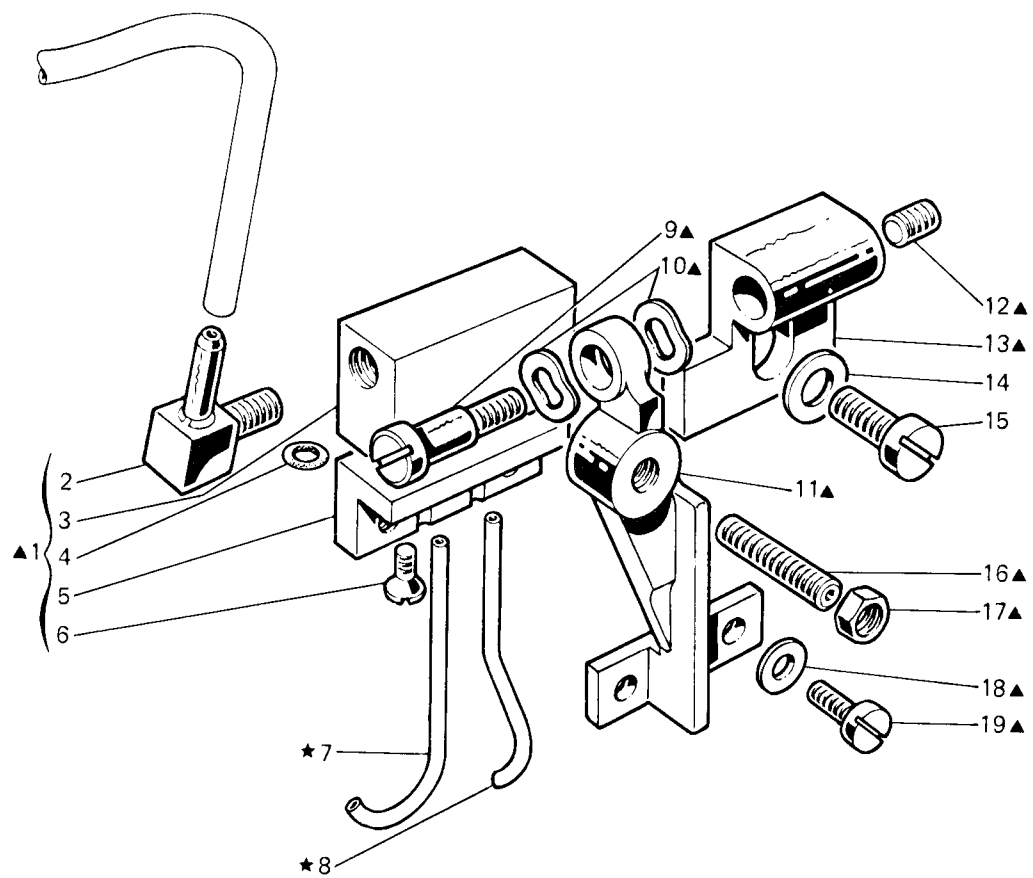

Fig. N. Abb. N.	Part. N. Piece N. Bestell N. Pieza N.	Qt. Anzahl	DESCRIZIONE	DESCRIPTION	DESCRIPTION	BENENNUNG	DESCRIPCION
★	925213.4-00	1	gruppo raffreddam. aghi (con fig. ▲)	needles cooling assembly (with fig. ▲)	groupe refroidissement aiguilles (avec fig. ▲)		
▲	925207.4-00	1	supporto distrib. completo	support assembly	support complet		
1	922453.4-00	1	distributore completo	distributor assembly	distributeur complet		
2	925761.0-01	1	attacco	pipe union	raccord		
3	922454.0-00	1	semicorpo superiore	upper half-body	semi-corps supérieur		
4	701000.0-00	2	anello di tenuta	retainer ring	bague d'étanchéité		
5	922455.0-00	1	semicorpo inferiore	lower half-body	semi-corps inférieur		
6	744631.2-00	2	vite	screw	vis		
7	922454.0-00	1	tubetto	pipe	tube		
8	922453.0-00	1	tubetto	pipe	tube		
9	743482.2-00	1	vite	screw	vis		
10	307605.0-00	2	anello di compensazione	ring	anneau		
11	925216.0-00	1	braccio	arm	bras		
12	729012.2-00	1	vite	screw	vis		
13	925217.0-00	1	supporto	support	support		
14	704226.2-00	1	rondella	washer	rondelle		
15	742623.2-00	1	vite	screw	vis		
16	729062.2-00	1	vite	screw	vis		
17	746007.2-00	1	dado	nut	écrou		
18	704104.2-00	2	rondella	washer	rondelle		
19	741675.2-00	2	vite	screw	vis		

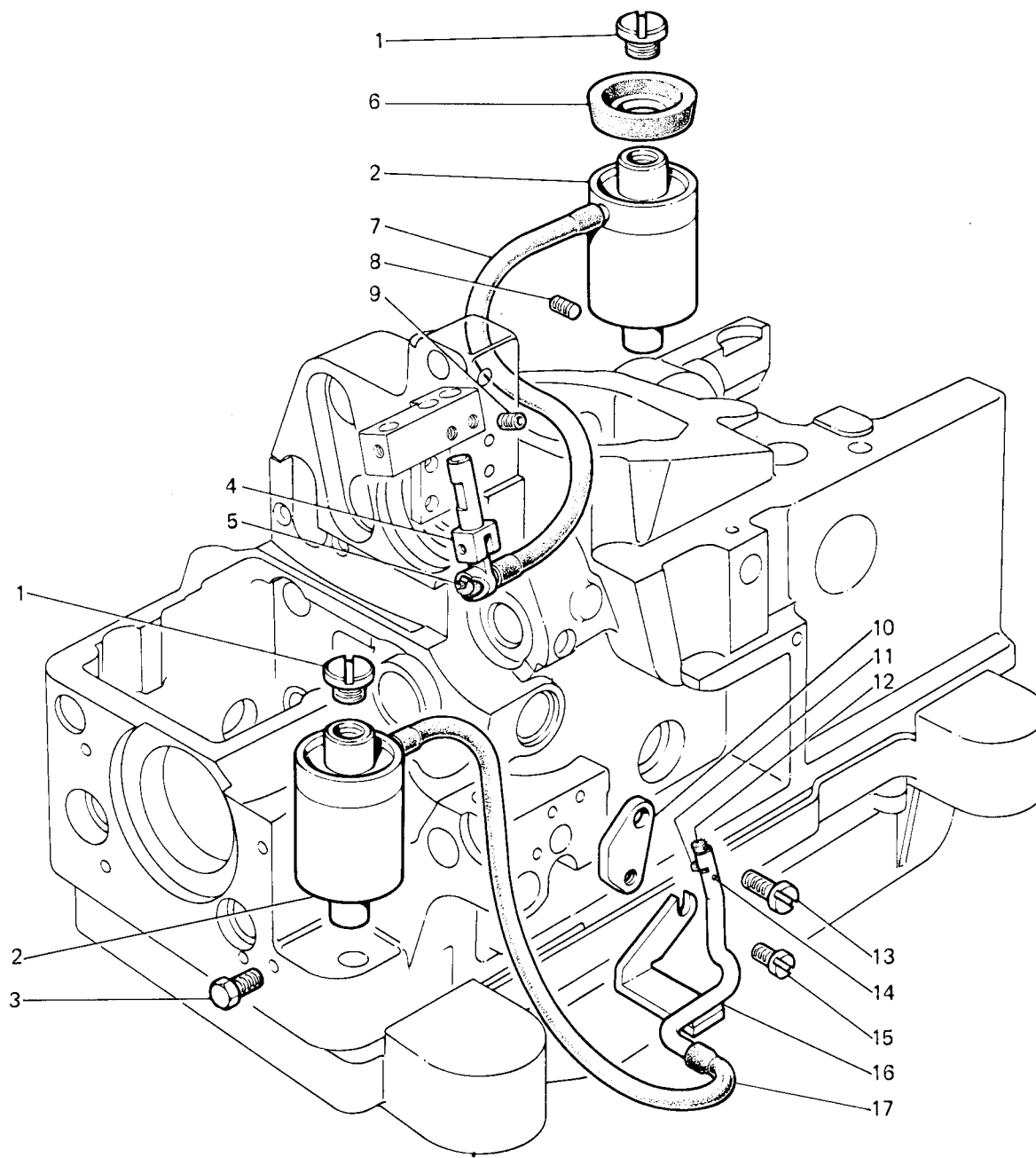

Fig. N. Abb. N.	Part. N. Bestell N. Piece N. Pieza N.	Qt. Anzahl	DESCRIZIONE	DESCRIPTION	DESCRIPTION	BENENNUNG	DESCRIPCION
1	207969-0-00	2	tappo	plug	bouchon		
2	207976-0-00	2	contenitore silicone	container	container		
3	740041-2-00	1	vite	screw	vis		
4	208219-3-00	1	supporto snodato compl.	support assembly	support complet		
5	778842-0-00	1	stoppino	wick	mèche		
6	208019-0-00	1	guarnizione	gasket	garniture		
7	208208-0-00	1	guaina	sheath	gaine		
8	729013-2-00	1	vite	screw	vis		
9	745800-2-00	1	vite	screw	vis		
10	208144-0-00	1	piastrina	plate	plaque		
11	778837-0-00	1	stoppino	wick	mèche		
12	778237-0-00	1	stoppino	wick	mèche		
13	722073-2-00	1	vite	screw	vis		
14	208209-0-00	1	spina	pin	goupille		
15	741634-2-00	1	vite	screw	vis		
16	208148-4-00	1	gruppo tubetto	pipe assembly	groupe tube		
17	208207-0-00	1	guaina	sheath	gaine		

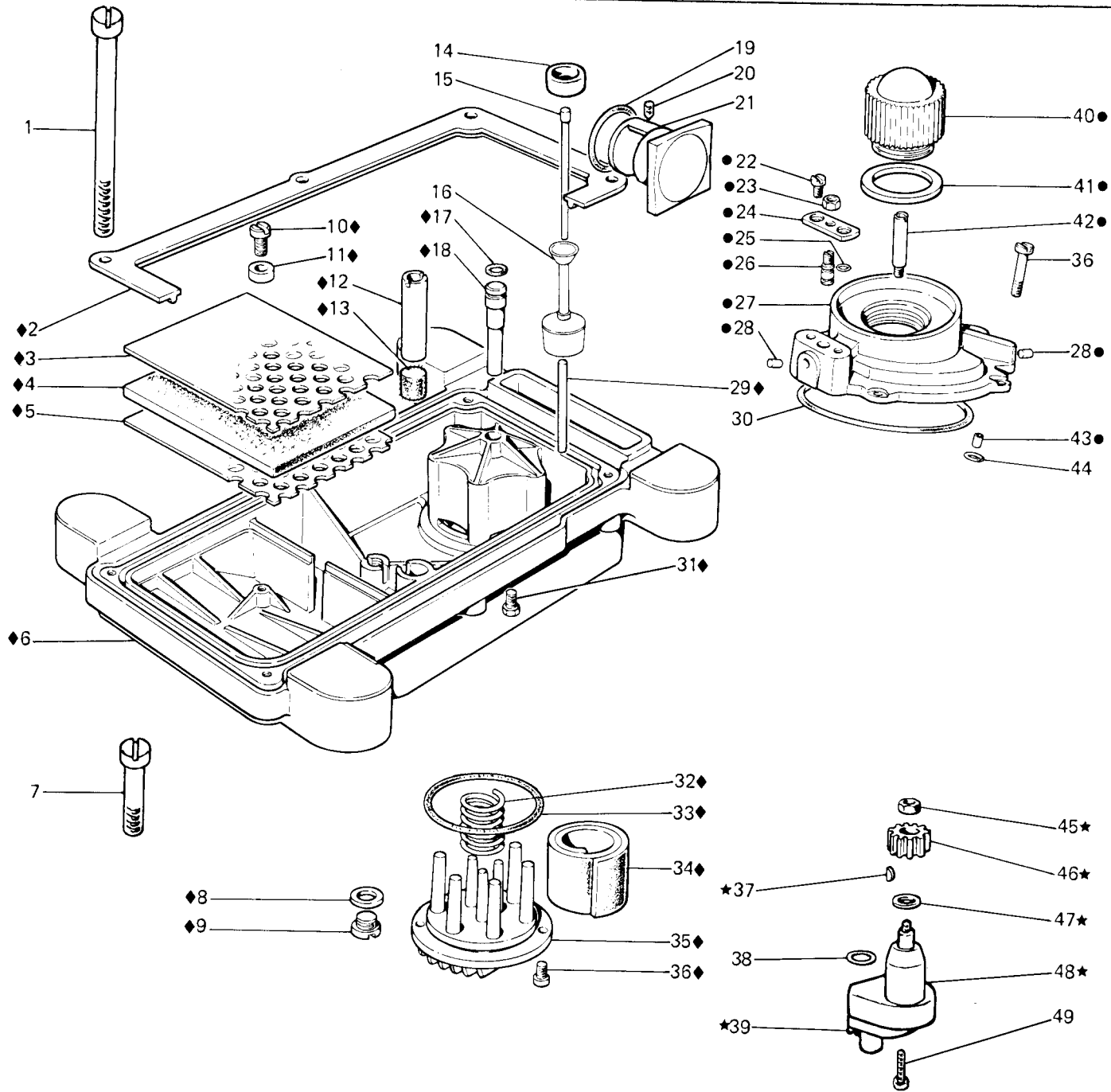

Fig. N. Abb. N.	Part. N. Piece N. Bestell N. Pieza N.	Qt. Anzahl	DESCRIZIONE	DESCRIPTION	DESCRIPTION	BENENNUNG	DESCRIPCION
●	207972-4-01	1	coperchio distrib. olio compl.	cover assembly	couvercle complet		
★	206550-4-03	1	gruppo pompa olio	oil pump assembly	groupe pompe à huile		
◆	208012-4-01	1	bacinella olio completa	oil sump assembly	réservoir huile complet		
1	207917-0-00	4	vite fissa bacinella	screw	vis		
2	207909-0-00	1	guarnizione bacinella	gasket	garniture		
3	206567-0-01	1	lamiera forata superiore	upper sheet	plaque perforée sup.		
4	206566-0-00	1	filtro	filter	filtre		
5	206565-0-01	1	lamiera forata inferiore	lower sheet	plaque perforée inf.		
6	207901-0-01	1	bacinella	oil sump	réservoir		
7	748086-2-00	1	vite fissa bacinella	screw	vis		
8	705977-0-00	1	rondella	washer	rondelle		
9	206564-0-00	1	tappo	plug	bouchon		
10	721484-2-00	1	vite	screw	vis		
11	990335-0-10	1	distanziale	spacer	entretoise		
12	206568-0-01	1	tubetto	pipe	tube		
13	206569-0-01	1	filtro	filter	filtre		
14	206667-0-00	1	tappo decompressione	plug	bouchon		
15	207975-0-00	1	astina indicat. liv. olio	stick	jauge niveau huile		
16	206665-2-00	1	galleggiante completo	float assembly	flotteur complet		
17	701005-0-00	1	anello di tenuta	retainer ring	bague d'étanchéité		
18	206558-0-01	1	tubo aspirante	pipe	tube		
19	701031-0-00	1	anello di tenuta	retainer ring	bague d'étanchéité		
20	729022-2-00	1	vite	screw	vis		
21	208087-3-00	1	indicatore livello olio	oil level gauge	indicateur niveau huile		
22	741535-0-00	2	vite	screw	vis		
23	746007-2-00	1	dado	nut	écrou		
24	207979-0-00	1	piastrina	plate	plaque		
25	701002-0-00	1	anello di tenuta	retainer ring	bague d'étanchéité		
26	207978-0-00	1	pistoncino	piston	piston		
27	207970-2-01	1	coperchio con tappo	cover with plug	couvercle with bouchon		
28	301586-0-10	2	tappo	plug	bouchon		
29	206662-0-00	1	spina	pin	goupille		
30	701151-0-00	1	anello di tenuta	retainer ring	bague d'étanchéité		
31	720411-2-00	1	vite	screw	vis		
32	206545-0-00	1	spirale per coperchio	spiral for cover	spirale pour couvercle		
33	701051-0-00	1	guarnizione	gasket	garniture		
34	206559-0-01	1	filtro	filter	filtre		
35	206560-0-20	1	coperchio	cover	couvercle		
36	722063-2-00	6	vite	screw	vis		
37	206557-0-00	1	chiavetta	key	clavette		
38	701004-0-00	1	anello di tenuta	retainer ring	bague d'étanchéité		
39	721494-2-00	2	vite	screw	vis		
40	207973-0-00	1	cupolina	cup	coupole		
41	705970-0-00	1	guarnizione	gasket	garniture		
42	207971-0-00	1	ugello	nozzle	gicleur		
43	207977-0-00	1	bussolina	bush	bague		
44	701106-0-00	1	anello di tenuta	retainer ring	bague d'étanchéité		
45	733507-0-00	1	dado	nut	écrou		
46	206555-0-01	1	ruota	wheel	roue		
47	704813-0-00	1	rondella	washer	rondelle		
48	206554-0-02	1	coperchio	cover	couvercle		
49	722511-2-00	2	vite	screw	vis		

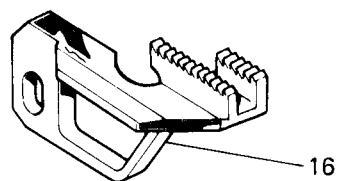
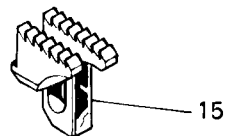
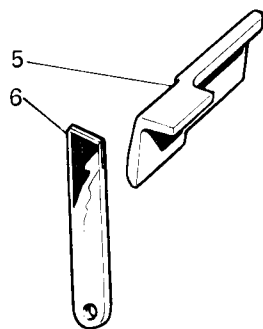
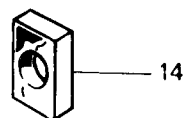
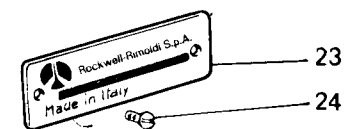
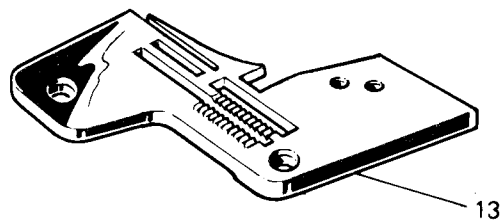
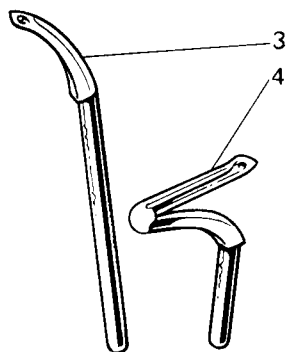
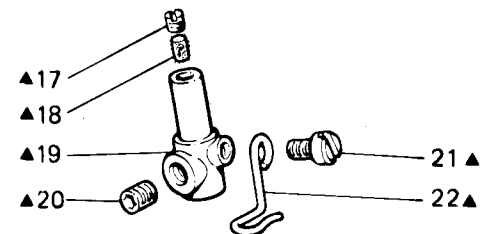
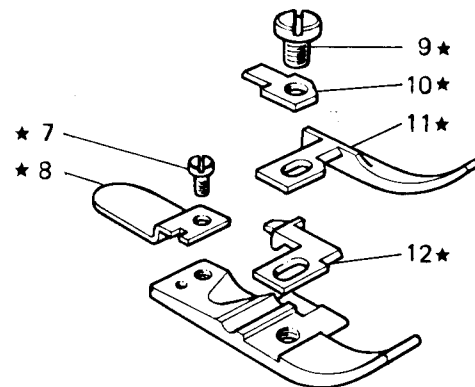
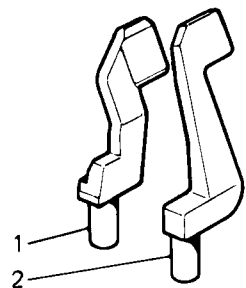

Fig. N. Abb. N.	Part. N. Bestell N. Pieca N. Pieza N.	Qt. Anzahl	DESCRIZIONE	DESCRIPTION	DESCRIPTION	BENENNUNG	DESCRIPCION
★	943209-3-00	1	piedino completo	presserfoot assembly	pied-presseur complet		
▲	207510-4-00	1	morsetto porta aghi compl.	needles clamp assembly	porte-aiguilles complet		
1	207992-0-00	1	salva ago	rear needle guard	protège-aiguille		
2	207995-0-00	1	spingi asola	front needle guard	pare-boucle		
3	204021-0-10	1	crochet superiore	upper looper	crochet supérieur		
4	202095-0-11	1	crochet inferiore	lower looper	crochet inférieur		
5	207000-2-00	1	coltello superiore	upper knife	couteau supérieur		
6	207015-2-00	1	coltello inferiore	lower knife	couteau inférieur		
7	741413-2-00	1	vite	screw	vis		
8	921459-0-10	1	piastrina	plate	plaque		
9	741675-2-00	1	vite	screw	vis		
10	943213-0-00	1	staffa	bracket	bride		
11	943211-0-00	1	guida	guide	guide		
12	943212-0-00	1	linguetta	tongue	languette		
13	943208-0-01	1	placca ago larg. costa 5 mm	needle plate width bight 5 mm	plaque à aiguille larg. surjet 5 mm		
14	203426-0-10	1	finto griffino	mock feed dog	fausse griffe		
15	203031-0-10	1	griffa sussidiaria	subsidiary feed dog	griffe subsidiaire		
16	943214-0-00	1	griffa principale	main feed dog	griffe principale		
17	727021-0-00	1	vite	screw	vis		
18	778206-0-00	1	stoppino	wick	mèche		
19	207520-2-00	1	morsetto porta aghi	needles clamp	porte-aiguilles		
20	745810-2-00	1	vite	screw	vis		
21	741415-2-00	1	vite	screw	vis		
22	207540-0-00	1	guidafilo	thread guide	guide-fil		
23	780227-0-40	1	targhetta classe testa	head class plate	plaque classe tête		
24	202165-0-10	2	vite	screw	vis		

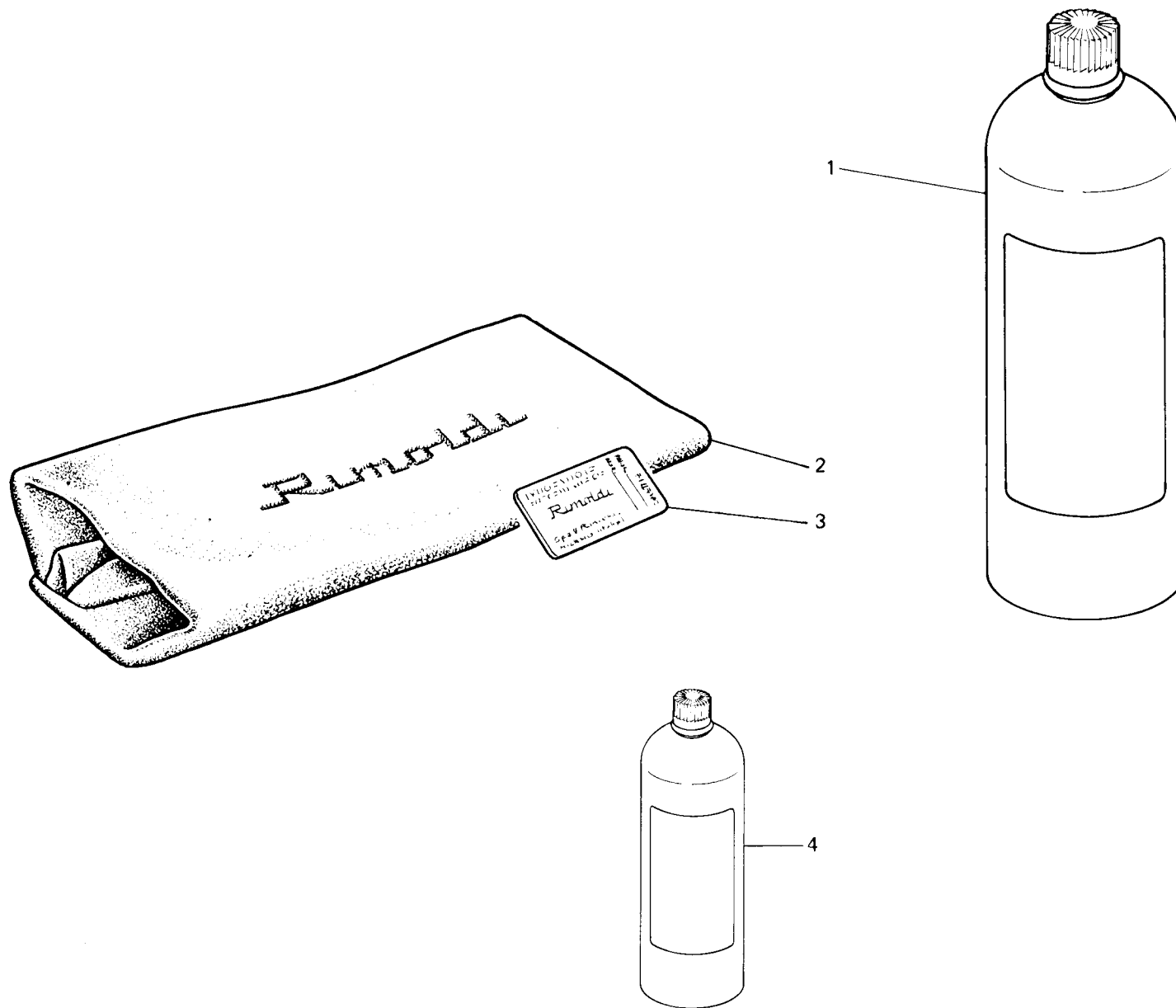

Fig. N. Abb. N.	Part. N. Bestell N. Piece N. Pieza N.	Qt. Anzahl	DESCRIZIONE	DESCRIPTION	DESCRIPTION	BENENNUNG	DESCRIPCION
1	990075-0-13	1	lattina olio da 1 kg.	oil container 1 kg.		bidon huile 1 kg	
2	990183-0-13	1	cuffia protezione testa	machine cover		couverture protection tête	
3	★	1	bustina aghi	needles packet		paquette aiguilles	
4	990934-0-00	1	barattolo olio con silicone	oil can		cuve huile	
			★ per l'ordinazione della bustina citare lo stesso simbolo dell'ago montato sulla testa	to order packet of needle please specify symbol of needle fitted on machine		pour commander un sachet d'aiguille donner le symbole de l'aiguille monté sur la tête	

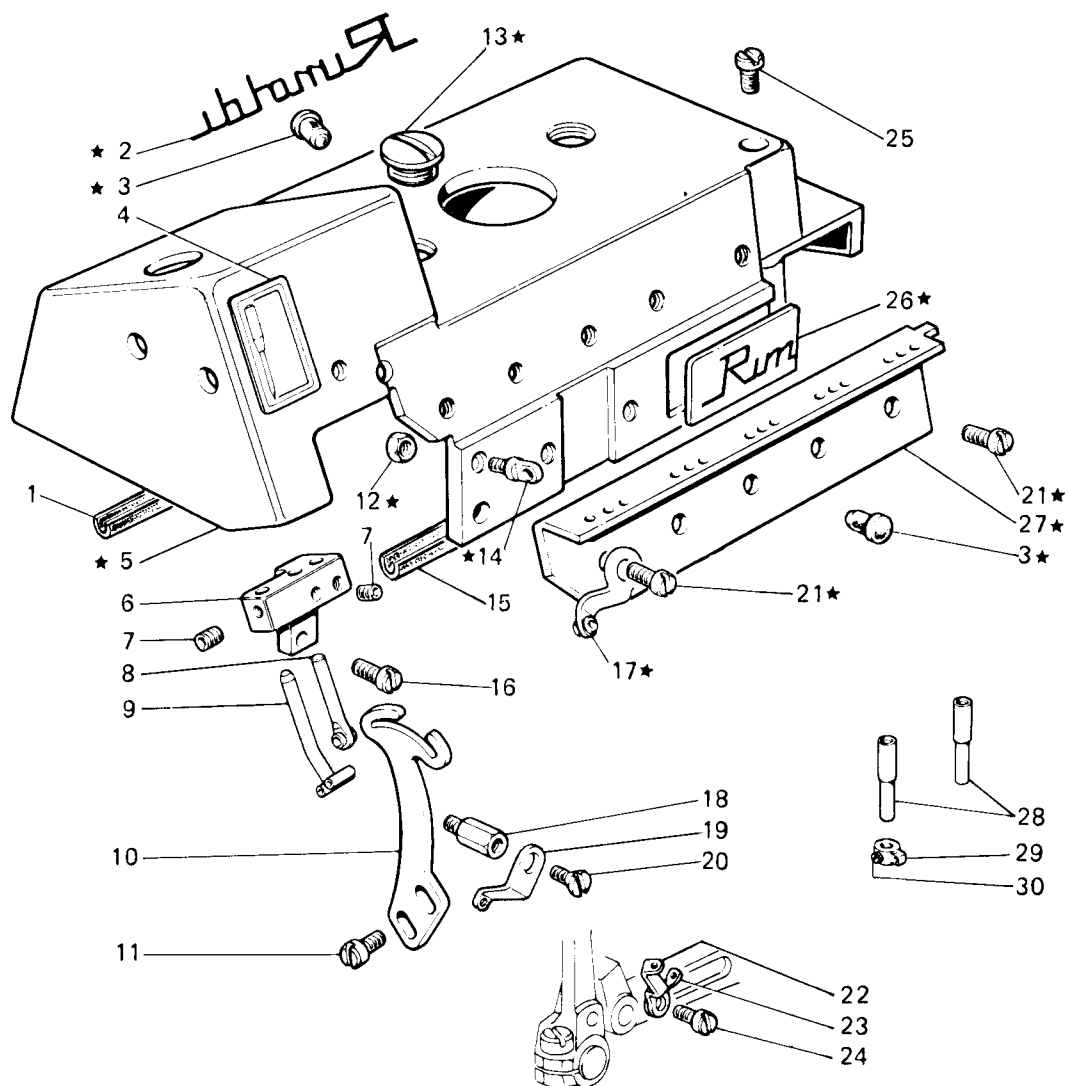

Fig. N. Abb. N.	Part. N. Bestell N. Piece N. Pieza N.	Qt. Anzahl	DESCRIZIONE	DESCRIPTION	DESCRIPTION	BENENNUNG	DESCRIPCION
★	208120-4-00	1	coperchio superiore completo	upper cover assembly	couvercle supérieur complet		
1	208091-0-00	1	guarnizione	gasket	garniture		
2	100305-0-10	1	decalcomania	decalcomania	décalcomanie		
3	207893-0-00	5	tappo	plug	bouchon		
4	788001-0-01	1	decalcomania sist. aghi	needles syst. décalcomania	décalcomanie syst. aiguilles		
5	207912-0-00	1	coperchio superiore	upper cover	couvercle supérieur		
6	207916-0-00	1	supporto passafili aghi	needles thread guide support	support passe-fil aiguilles		
7	745800-2-00	2	vite	screw	vis		
8	208184-2-00	1	passafilo	thread guide	passe-fil		
9	203647-2-13	1	passafilo	thread guide	passe-fil		
10	207871-0-00	1	tendifilo	thread take-up	tendeur du fil		
11	741558-0-00	2	vite	screw	vis		
12	733503-0-00	3	dado	nut	écrou		
13	207968-0-01	1	tappo	plug	bouchon		
14	206711-0-00	3	passafilo	thread guide	passe-fil		
15	208090-0-00	1	guarnizione	gasket	garniture		
16	741956-2-00	2	vite	screw	vis		
17	206713-2-00	1	passafilo	thread guide	passe-fil		
18	206755-0-00	1	colonnina	column	colonne		
19	204035-0-10	1	passafilo crochet sup.	upper looper thread guide	passe-fil crochet sup.		
20	744631-2-00	1	vite	screw	vis		
21	721484-2-00	3	vite fissa coperchio sup.	screw	vis		
22	202281-0-10	1	tendifilo crochet sup.	thread take-up	tendeur du fil		
23	202279-0-10	1	tendifilo crochet inf.	thread take-up	tendeur du fil		
24	741675-0-00	1	vite	screw	vis		
25	202397-0-10	2	vite	screw	vis		
26	208089-0-00	1	targhetta	plate	plaquette		
27	208057-0-00	1	piastra passafili	plate	plaque		
28	206740-0-00	2	tubetto passafilo	pipe	tube		
29	203135-2-10	1	passafilo con vite	thread guide	passe-fil		
30	745002-0-00	1	vite	screw	vis		
			SOLO A RICHIESTA	ONLY ON REQUEST	SEULEMENT SUR DEMANDE		
—	208310-4-00	1	gruppo passafili	thread guide assembly	groupe passe-fil		
8	208179-2-00	1	passafilo	thread guide	passe-fil		
9	208196-3-00	1	passafilo	thread guide	passe-fil		
12	733503-0-00	3	dado	nut	écrou		
14	208204-2-00	3	passafilo	thread guide	passe-fil		

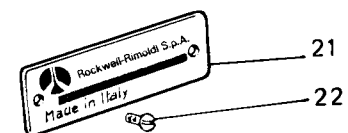
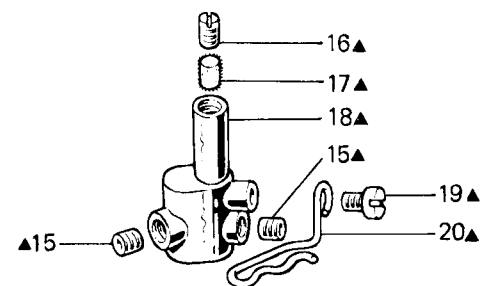
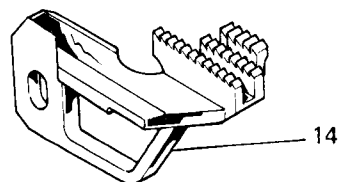
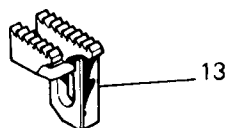
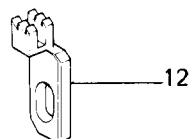
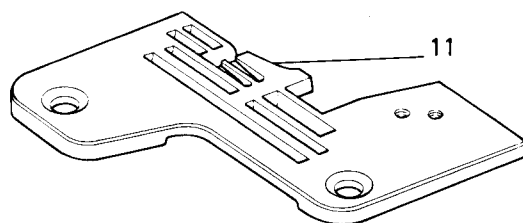
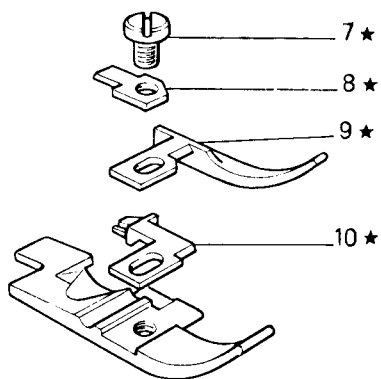
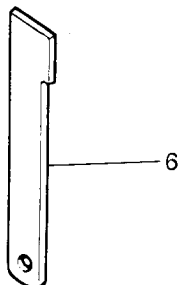
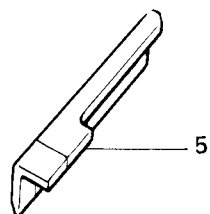
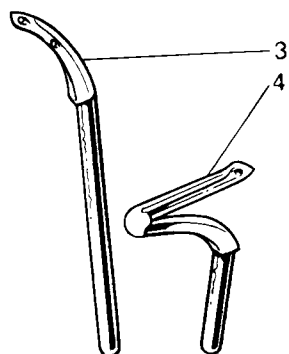
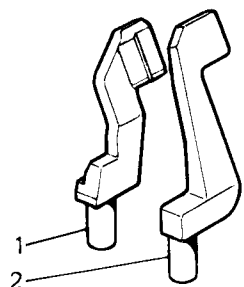
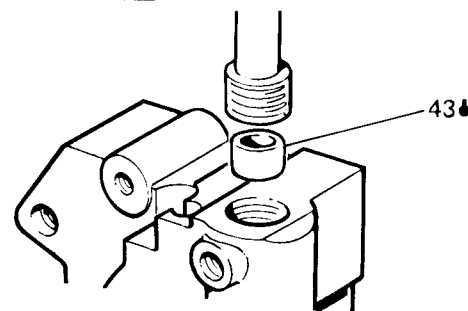

Fig. N. Abb. N.	Part. N. Bestell N. Piece N. Pieza N.	Qt. Anzahl	DESCRIZIONE	DESCRIPTION	DESCRIPTION	BENENNUNG	DESCRIPCION
★	944150-3-00	1	piedino completo	presserfoot assembly	pied-presseur complet		
▲	207512-4-00	1	morsetto porta aghi	needles clamp	porte-aiguilles		
1	207994-0-00	1	salva ago	rear needle guard	protège-aiguille		
2	207997-0-00	1	spingi asola	front needle guard	pare-boucle		
3	207059-0-00	1	crochet superiore	upper looper	crochet supérieur		
4	202094-0-11	1	crochet inferiore	lower looper	crochet inférieur		
5	207001-2-00	1	coltello superiore	upper knife	couteau supérieur		
6	203012-0-10	1	coltello inferiore	lower knife	couteau inférieur		
7	741675-2-00	1	vite	screw	vis		
8	943213-0-00	1	staffa	bracket	bride		
9	944153-0-00	1	guida	guide	guide		
10	944152-0-00	1	linguetta	tongue	languette		
11	944157-0-00	1	placca ago larg. costa 5,5 mm	needle plate width bight 5,5 mm	plaque à aiguille larg. surjet 5,5 mm		
12	944155-0-00	1	griffino	feed dog	petite griffe		
13	203540-0-10	1	griffa sussidiaria	subsidiary feed dog	griffe subsidiaire		
14	944159-0-00	1	griffa principale	main feed dog	griffe principale		
15	745810-2-00	2	vite	screw	vis		
16	727021-0-00	1	vite	screw	vis		
17	778206-0-00	1	stoppino	wick	mèche		
18	207522-2-00	1	morsetto porta aghi	needles clamp	porte-aiguilles		
19	741415-2-00	1	vite	screw	vis		
20	207542-0-00	1	guidafilo	thread guide	guide-fil		
21	780251-0-40	1	targhetta classe testa	head class plate	plaque classe tête		
22	202165-0-10	2	vite	screw	vis		

Fig. N. Abb. N.	Part. N. Bestell N. Piece N. Pieza N.	Qt. Anzahl	DESCRIZIONE	DESCRIPTION	DESCRIPTION	BENENNUNG	DESCRIPCION
	<u>Tav. 6</u>						
★	206399-4-00	1	gruppo manicotto com. crochet	control looper assembly	groupe manchon comm. crochet		
▲	206417-4-00	1	gruppo comando crochet sup.	upper looper control assembly	groupe comm. crochet supérieur		
●	208039-4-00	1	gruppo porta crochet inferiore	lower looper holder assembly	groupe porte crochet inférieur		
1	206452-4-00	1	gruppo manicotto con biella	coupling ass. with con-rod	groupe manchon avec bielle		
6	206658-2-02	1	manicotto	coupling	manchon		
8	704848-0-00	1	rondella	washer	rondelle		
11	206451-4-00	1	gruppo manicotto con biella	coupling ass. with con-rod	groupe manchon avec bielle		
12	206649-2-02	1	manicotto	coupling	manchon		
13	704845-0-00	1	rondella	washer	rondelle		
19	745800-2-00	1	vite	screw	vis		
21	206412-3-00	1	guida oscillante	oscillating guide	guide oscillant		
23	778236-0-00	1	stoppino	wick	mèche		
30	206652-2-01	1	braccio	arm	bras		
	<u>Tav. 7</u>						
40	206541-2-00	1	manovella alb. sup. con vite	con-rod with screw	manivelle arbre couteau sup.		
	<u>Tav. 10</u>						
10	944156-0-01	1	rullino	roller	rouleau		
	<u>Tav. 3</u>		PEZZI ANNULLATI	CANCELLED PARTS	PIECES ANNULEES		
			ANNULLATA	CANCELLED	ANNULEE		

Fig. N. Abb. N.	Part. N. Bestell N. Piece N. Pieza N.	Qt. Anzahl	DESCRIZIONE	DESCRIPTION	DESCRIPTION	BENENNUNG	DESCRIPCION
▲	<u>Tav. 4</u> 206703-4-01	1	albero princ. con cuscinetti	main shaft with bearing	arbre princ. avec coussinet		
8	206700-2-01	1	albero principale	main shaft	arbre principal		
★	<u>Tav. 6</u> 206394-4-00	1	gruppo manicotti com. crochet	control looper assembly	groupe manchon comm. crochet		
▲	206428-4-00	1	gruppo comando crochet sup.	upper looper control assembly	groupe comm. crochet sup.		
●	208594-4-00	1	gruppo porta crochet inf.	lower looper holder assembly	groupe porte crochet inf.		
1	206452-4-00	1	gruppo manicotto con biella	coupling ass. with con-rod	groupe manchon avec bielle		
6	206658-2-01	1	manicotto	coupling	manchon		
8	704848-0-00	1	rondella	washer	rondelle		
11	206450-4-00	1	gruppo manicotto con biella	coupling ass. with con-rod	groupe manchon avec bielle		
12	206648-2-02	1	manicotto	coupling	manchon		
13	704840-0-00	1	rondella	washer	rondelle		
15	207603-0-00	1	squadretta	bracket	équerre		
21	206412-3-00	1	guida oscillante	oscillating guide	guide oscillant		
	<u>Tav. 7</u>						
23	765200-6-10	2	ago RIM 27 fin. 100	needle RIM 27 size 100	aiguille RIM 27 jauge 100		
40	206542-2-00	1	manovella alb. sup. con vite	con-rod with screw	bras arbre avec vis		
	<u>Tav. 8</u>						
41	208136-4-00	1	gruppo premistoffa	presser assembly	groupe pied-presseur		
43	205021-0-10	1	molla	spring	ressort		
	206882-0-00	1	distanziale	spacer	entretoise		
	<u>Tav. 9</u>						
15	206575-2-00	1	manovella alb. coltello sup.	crank for upper knife shaft	manivelle arbre couteau sup.		
	<u>Tav. 10</u>						
10	944156-0-01	1	rullino	roller	rouleau		
			PEZZI ANNULLATI	CANCELLED PARTS	PIECES ANNULEES		
	<u>Tav. 3</u>		ANNULLATA	CANCELLED	ANNULEE		

TAV. 8



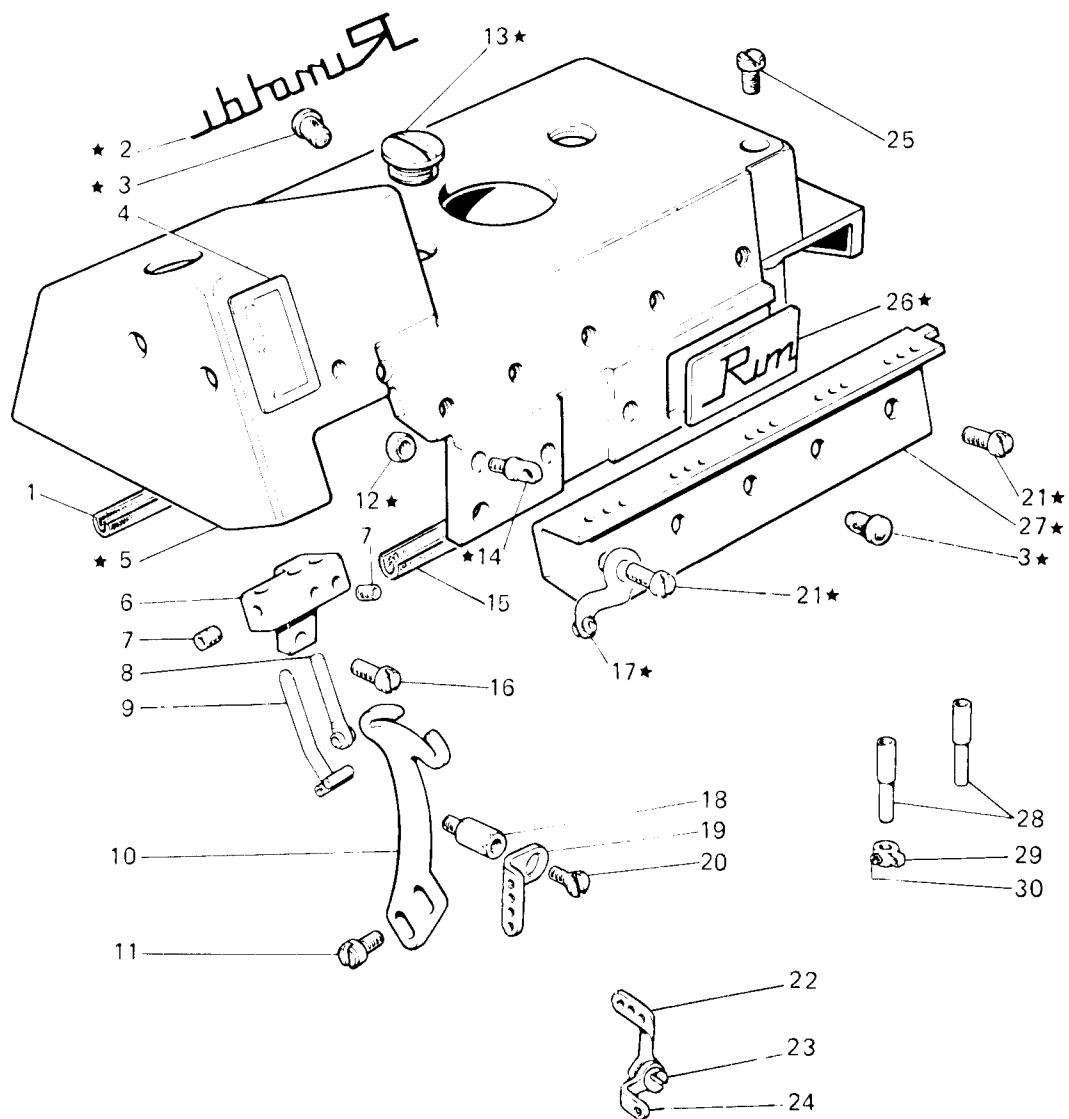

Fig. N. Abb. N.	Part. N. Piecce N. Bestell N. Pieza N.	Qt. Anzahl	DESCRIZIONE	DESCRIPTION	DESCRIPTION	BENENNUNG	DESCRIPCION
★	208120-4-00	1	coperchio superiore completo	upper cover assembly	couvercle supérieur compl.		
1	208091-0-00	1	guarnizione	gasket	garniture		
2	100305-0-10	1	decalcomania	decalcomania	décalcomanie		
3	207893-0-00	5	tappo	plug	bouchon		
4	788001-0-01	1	decalcomania sist. aghi	needles syst. decalcomania	décalcomanie syst. aiguilles		
5	207912-0-00	1	coperchio superiore	upper cover	couvercle supérieur		
6	207916-0-00	1	supporto passafili aghi	needles thread guide support	support passe-fil aiguilles		
7	745800-2-00	2	vite	screw	vis		
8	208184-2-00	1	passafilo	thread guide	passe-fil		
9	203647-2-13	1	passafilo	thread guide	passe-fil		
10	207871-0-00	1	tendifilo	thread take-up	tendeur du fil		
11	741558-0-00	2	vite	screw	vis		
12	733503-0-00	3	dado	nut	écrou		
13	207968-0-01	1	tappo	plug	bouchon		
14	206711-0-00	3	passafilo	thread guide	passe-fil		
15	208090-0-00	1	guarnizione	gasket	garniture		
16	741956-2-00	2	vite	screw	vis		
17	206713-2-00	1	passafilo	thread guide	passe-fil		
18	207602-0-00	1	colonnina	column	colonne		
19	207600-0-00	1	passafilo crochet sup.	upper looper thread guide	passe-fil crochet sup.		
20	744631-2-00	1	vite	screw	vis		
21	202397-0-10	2	vite	screw	vis		
22	300331-0-10	1	tendifilo crochet sup.	upper looper thread take-up	tendeur du fil crochet sup.		
23	741675-0-00	1	vite	screw	vis		
24	920846-0-00	1	tendifilo crochet inf.	lower looper thread take-up	tendeur du fil crochet inf.		
25	721484-2-00	3	vite	screw	vis		
26	208089-0-00	1	targhetta	plate	plaque		
27	208057-0-00	1	piastra passafili	plate	plaque		
28	206740-0-00	2	tubetto passafilo	pipe	tube		
29	203135-2-10	1	passafilo con vite	thread guide with screw	passe-fil avec vis		
30	745002-0-00	1	vite	screw	vis		
			SOLO A RICHIESTA	ONLY ON REQUEST	SEULEMENT SUR DEMANDE		
—	208310-4-00	1	gruppo passafili	thread guide assembly	groupe passe-fil		
8	208179-2-00	1	passafilo	thread guide	passe-fil		
9	208196-3-00	1	passafilo	thread guide	passe-fil		
12	733503-0-00	3	dado	nut	écrou		
14	208204-2-00	3	passafilo	thread guide	passe-fil		

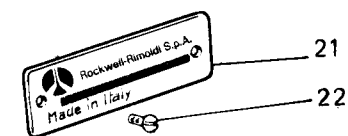
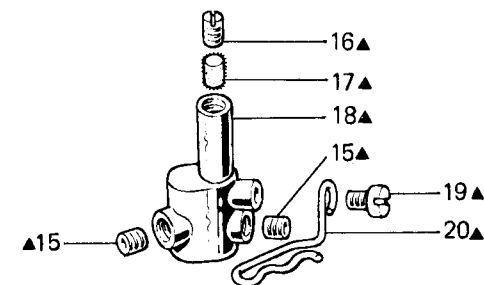
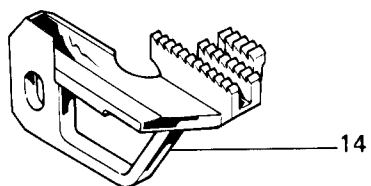
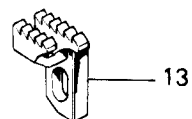
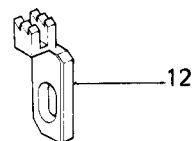
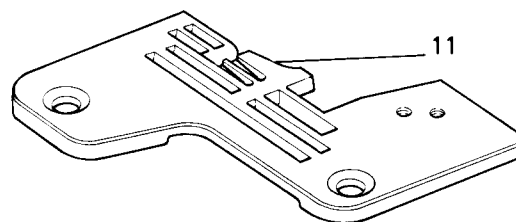
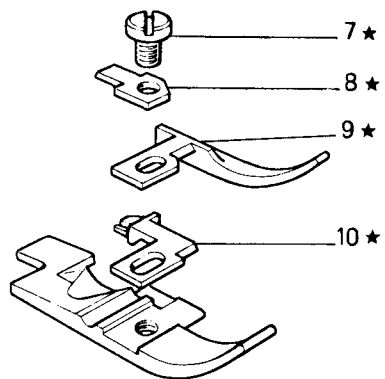
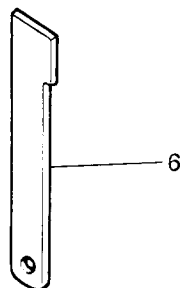
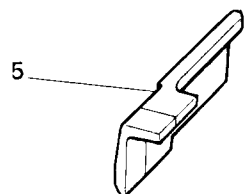
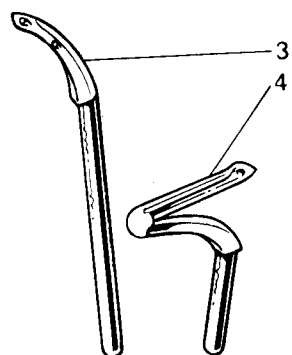
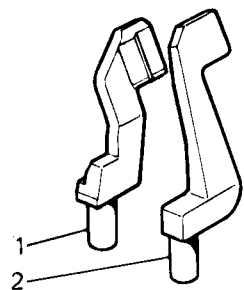

Fig. N. Abb. N.	Part. N. Piece N. Bestell N. Pieza N.	Qt. Anzahl	DESCRIZIONE	DESCRIPTION	DESCRIPTION	BENENNUNG	DESCRIPCION
★	944150-3-00	1	piedino completo	presserfoot assembly	pied-presseur complet		
▲	207512-4-00	1	morsetto porta aghi completo	needles clamp assembly	porte-aiguilles complet		
1	207994-0-00	1	salva ago	rear needle guard	protège-aiguille		
2	207997-0-00	1	spingi asola	front needle guard	pare-boucle		
3	204022-0-10	1	crochet superiore	upper looper	crochet supérieur		
4	202095-0-11	1	crochet inferiore	lower looper	crochet inférieur		
5	207003-2-00	1	coltello superiore	upper knife	couteau supérieur		
6	203012-0-10	1	coltello inferiore	lower knife	couteau inférieur		
7	741675-2-00	1	vite	screw	vis		
8	943213-0-00	1	staffa	bracket	bride		
9	944153-0-00	1	guida	guide	guide		
10	944152-0-00	1	linguetta	tongue	languette		
11	944157-0-00	1	placca ago larg. costa 5,5 mm	needle plate width bight 5,5 mm	plaque à aiguille larg. surjet 5,5 mm		
12	944155-0-00	1	griffino	feed dog	petite griffe		
13	203609-0-10	1	griffa sussidiaria	subsidiary feed dog	griffe subsidiaire		
14	944154-0-00	1	griffa principale	main feed dog	griffe principale		
15	745810-2-00	2	vite	screw	vis		
16	727021-0-00	1	vite	screw	vis		
17	778206-0-00	1	stoppino	wick	mèche		
18	207522-2-00	1	morsetto porta aghi	needles clamp	porte-aiguilles		
19	741415-2-00	1	vite	screw	vis		
20	207542-0-00	1	guidafilo	thread guide	guide-fil		
21	780261-0-40	1	targhetta classe testa	head class plate	plaque classe tête		
22	202165-0-10	2	vite	screw	vis		

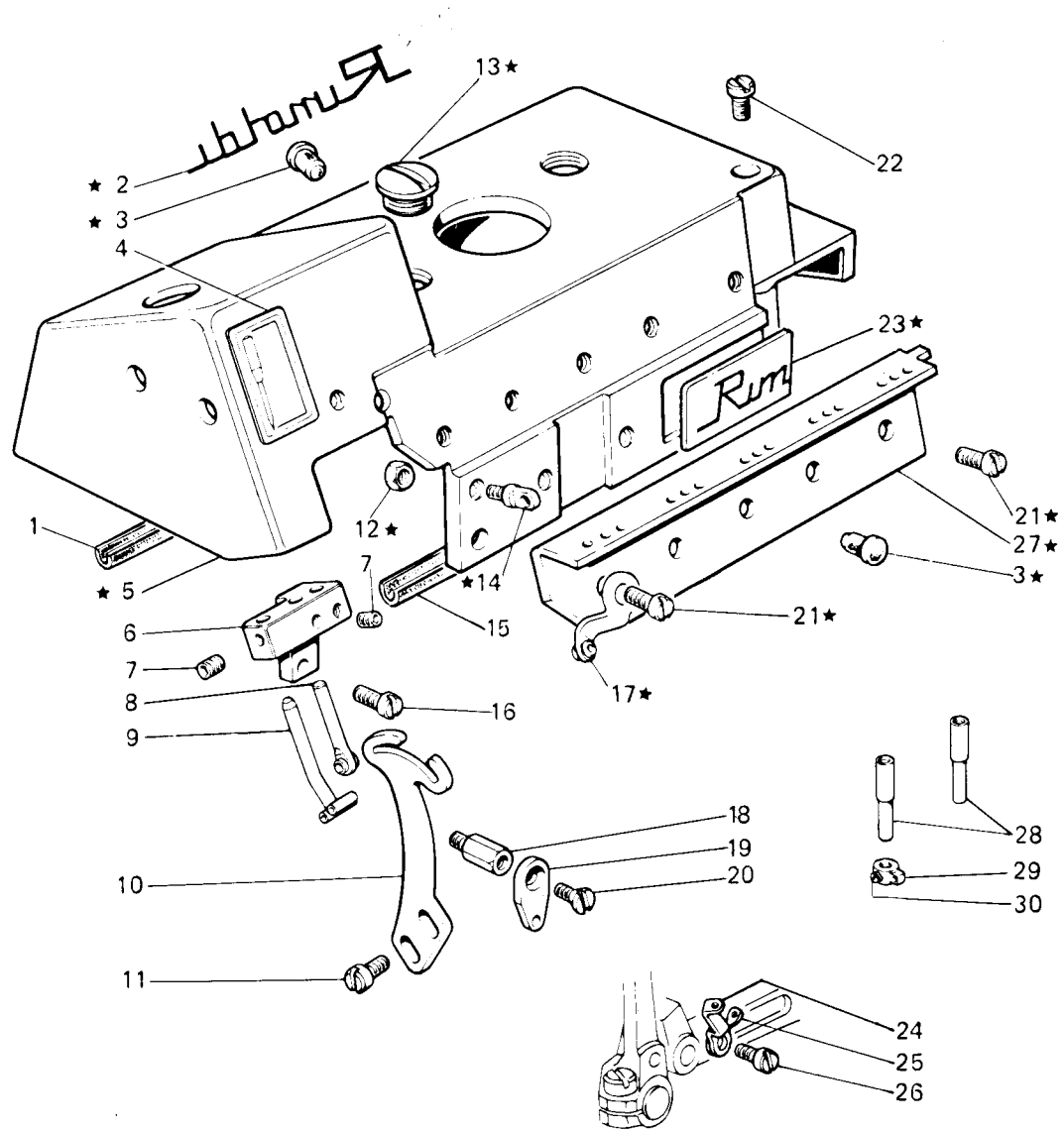

Fig. N. Abb. N.	Part. N. Bestell N. Pieça N. Pieza N.	Qt. Anzahl	DESCRIZIONE	DESCRIPTION	DESCRIPTION	BENENNUNG	DESCRIPCION
★	208120-4-00	1	coperchio superiore completo	upper cover assembly	couvercle supérieur compl.		
1	208091-0-00	1	guarnizione	gasket	garniture		
2	100305-0-10	1	decalcomania	decalcomania	décalcomanie		
3	207893-0-00	5	tappo	plug	bouchon		
4	788000-0-01	1	decalcomania sist. aghi	needles syst. decalcomania	décalcomanie syst. aiguilles		
5	207912-0-00	1	coperchio superiore	upper cover	couvercle supérieur		
6	207916-0-00	1	supporto passafili aghi	needles thread guide support	support passe-fil aiguilles		
7	745800-2-00	2	vite	screw	vis		
8	208184-2-00	1	passafilo	thread guide	passe-fil		
9	203647-2-13	1	passafilo	thread guide	passe-fil		
10	207871-0-00	1	tendifilo	thread take-up	tendeur du fil		
11	741558-0-00	2	vite	screw	vis		
12	733503-0-00	3	dado	nut	écrou		
13	207968-0-01	1	tappo	plug	bouchon		
14	206711-0-00	3	passafilo	thread guide	passe-fil		
15	208090-0-00	1	guarnizione	gasket	garniture		
16	741956-2-00	2	vite	screw	vis		
17	206713-2-00	1	passafilo	thread guide	passe-fil		
18	206755-0-00	1	colonnina	column	colonne		
19	205035-0-10	1	passafilo crochet sup.	upper looper thread guide	passe-fil crochet sup.		
20	744631-2-00	1	vite	screw	vis		
21	202397-0-10	2	vite	screw	vis		
22	721484-2-00	3	vite	screw	vis		
23	208089-0-00	1	targhetta	plate	plaque		
24	202281-0-10	1	tendifilo crochet sup.	upper looper thread take-up	tendeur du fil crochet sup.		
25	202279-0-10	1	tendifilo crochet inf.	lower looper thread take-up	tendeur du fil crochet inf.		
26	741675-0-00	1	vite	screw	vis		
27	208057-0-00	1	piastra passafili	plate	plaque		
28	206740-0-00	2	tubetto passafilo	pipe	tube		
29	203135-2-10	1	passafilo con vite	thread guide with screw	passe-fil avec vis		
30	745002-0-00	1	vite	screw	vis		
			SOLO A RICHIESTA	ONLY ON REQUEST	SEULEMENT SUR DEMANDE		
—	208310-4-00	1	gruppo passafili	thread guide assembly	groupe passe-fil		
8	208179-2-00	1	passafilo	thread guide	passe-fil		
9	208196-3-00	1	passafilo	thread guide	passe-fil		
12	733503-0-00	3	dado	nut	écrou		
14	208204-2-00	3	passafilo	thread guide	passe-fil		

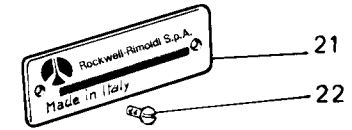
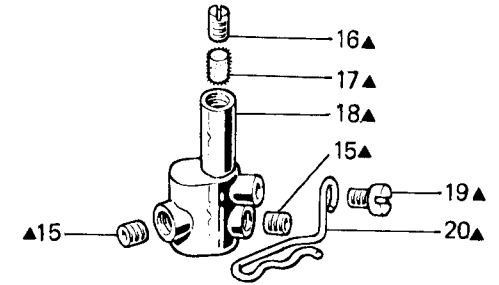
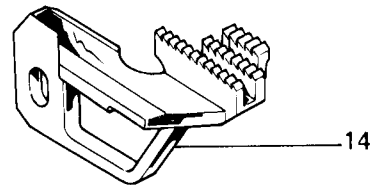
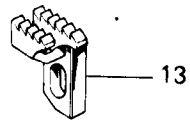
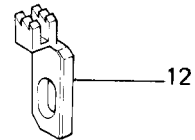
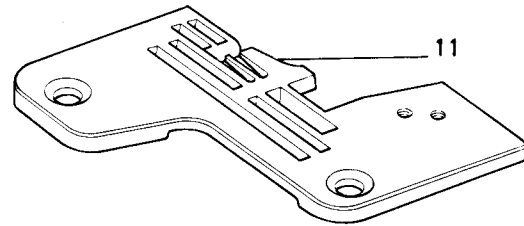
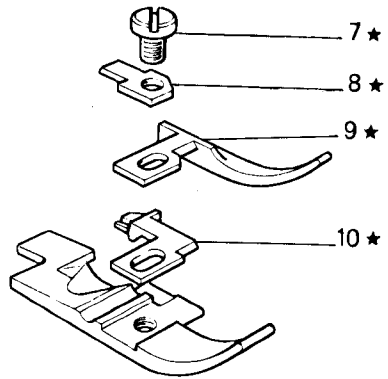
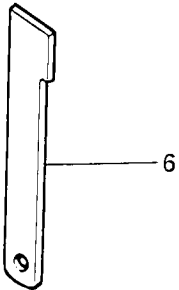
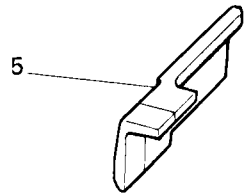
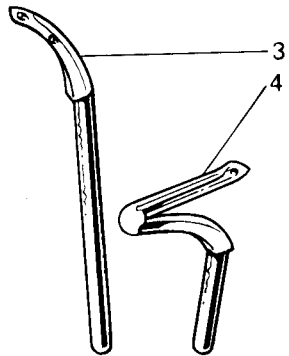
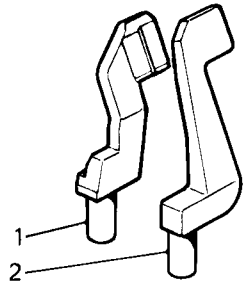

Fig. N. Abb. N.	Part. N. Bestell N. Piece N. Pieza N.	Qt. Anzahl	DESCRIZIONE	DESCRIPTION	DESCRIPTION	BENENNUNG	DESCRIPCION
★	944150-3-00	1	piedino completo	presserfoot assembly	pied-presseur complet		
▲	207513-4-00	1	morsetto porta aghi completo	needles clamp assembly	porte-aiguilles complet		
1	207993-0-00	1	salva ago	rear needle guard	protège-aiguille		
2	207996-0-00	1	spingi asola	front needle guard	pare-boucle		
3	204022-0-10	1	crochet superiore	upper looper	crochet supérieur		
4	202095-0-11	1	crochet inferiore	lower looper	crochet inférieur		
5	207003-2-00	1	coltello superiore	upper knife	couteau supérieur		
6	203012-0-10	1	coltello inferiore	lower knife	couteau inférieur		
7	741675-2-00	1	vite	screw	vis		
8	943213-0-00	1	staffa	bracket	bride		
9	944153-0-00	1	guida	guide	guide		
10	944152-0-00	1	linguetta	tongue	languette		
11	944158-0-00	1	placca ago larg. costa 5,5 mm	needle plate width bight 5,5 mm	plaque à aiguille larg. surjet 5,5 mm		
12	944155-0-00	1	griffino	feed dog	petite griffe		
13	203609-0-10	1	griffa sussidiaria	subsidiary feed dog	griffe subsidiaire		
14	944154-0-00	1	griffa principale	main feed dog	griffe principale		
15	745810-2-00	2	vite	screw	vis		
16	727021-0-00	1	vite	screw	vis		
17	778206-0-00	1	stoppino	wick	mèche		
18	207523-2-00	1	morsetto porta aghi	needles clamp	porte-aiguilles		
19	741415-2-00	1	vite	screw	vis		
20	207542-0-00	1	guidafilo	thread guide	guide-fil		
21	780262-0-40	1	targhetta classe testa	head class plate	plaque classe tête		
22	202165-0-10	2	vite	screw	vis		

Fig. N. Abb. N.	Part. N. Bestell N. Piece N. Pieza N.	Qt. Anzahl	DESCRIZIONE	DESCRIPTION	DESCRIPTION	BENENNUNG	DESCRIPCION
▲	<u>Tav. 4</u> 206703-4-01	1	albero princ. con cuscinetti	main shaft with bearing	arbre princ. avec coussinet		
8	206700-2-01	1	albero principale	main shaft	arbre principal		
★	<u>Tav. 6</u> 206394-4-00	1	gruppo manicotti com. crochet	control looper assembly	groupe manchon comm. crochet		
▲	206428-4-00	1	gruppo comando crochet sup.	upper looper control assembly	groupe comm. crochet sup.		
●	208039-4-00	1	gruppo porta crochet inf.	lower looper holder assembly	groupe porte crochet inf.		
1	206452-4-00	1	gruppo manicotto con biella	coupling ass. with con-rod	groupe manchon avec bielle		
6	206658-2-01	1	manicotto	coupling	manchon		
8	704848-0-00	1	rondella	washer	rondelle		
11	206450-4-00	1	gruppo manicotto con biella	coupling ass. with con-rod	groupe manchon avec bielle		
12	206648-2-02	1	manicotto	coupling	manchon		
13	704840-0-00	1	rondella	washer	rondelle		
15	208015-0-00	1	squadretta	bracket	équerre		
21	206412-3-00	1	guida oscillante	oscillating guide	guide oscillant		
	<u>Tav. 7</u>						
23	765000-6-90	2	ago RIM 27 fin. 90	needle RIM 27 size 90	aiguille RIM 27 jauge 90		
40	206542-2-00	1	manovella alb. sup. con vite	con-rod with screw	bras arbre avec vis		
	<u>Tav. 8</u>						
41	208136-4-00	1	gruppo premistoffa	presser assembly	groupe pied-presseur		
43	205021-0-10	1	molla	spring	ressort		
	206882-0-00	1	distanziale	spacer	entretoise		
	<u>Tav. 9</u>						
15	206575-2-00	1	manovella alb. coltello sup.	crank for upper knife shaft	manivelle arbre couteau sup.		
	<u>Tav. 10</u>						
10	944156-0-01	1	rullino	roller	rouleau		
	<u>Tav. 3</u>						
			PEZZI ANNULLATI	CANCELLED PARTS	PIECES ANNULEES		
			ANNULLATA	CANCELLED	ANNULEE		

TAV. 8

