

529-00-2CD-03  
529-00-2CD-04  
529-00-2CD-09  
529-00-2CD-11  
529-00-2CD-12  
529-00-2CD-22  
529-22-2CD-02  
529-23-2CD-02

1ªEDIZIONE – EDITION 6/83

**n. 239**

SOLO I PEZZI DI RICAMBIO ORIGINALI RIMOLDI MARCATI **Rim**<sup>®</sup>  
GARANTISCONO EFFETTIVA INTERCambiABILITÀ, FUNZIONALITÀ, DURATA

ONLY GENUINE RIMOLDI SPARE PARTS TRADEMARKED **Rim**<sup>®</sup>  
GUARANTEE EFFECTIVE INTERCHANGEABILITY, EXCELLENT QUALITY LONG LIFE

SEULEMENT LES PIÈCES DÉTACHÉES D'ORIGINE RIMOLDI MARQUÉES **Rim**<sup>®</sup>  
GARANTISSENT UNE INTERCHANGEABILITÉ UN FONCTIONNEMENT ET UNE DURÉE EFFECTIFS

Il presente Catalogo Pezzi di Ricambio è costituito da due parti: la prima, definita come "Catalogo base", comprende i particolari montati sulla testa più significativa (la prima dell'elenco in copertina); la seconda comprende tutti i particolari delle altre teste basi o derivate, che differiscono da quella del Catalogo base.

Le Teste basi sono elencate in copertina con un carattere più grande rispetto a quello delle derivate.

Nella consultazione del Catalogo tenere presente che

1. Tutti i particolari non fornibili sciolti non vengono richiamati singolarmente, ma soltanto illustrati nel gruppo d'appartenenza.
2. I riferimenti delle figure dei particolari che compongono il gruppo sono di norma raggruppati in una parentesi. In alcuni casi però, dove non è possibile il raggruppamento, i numeri che nelle tavole illustrative richiamano i singoli pezzi sono affiancati dallo stesso segno particolare, con cui è indicato l'intero gruppo.
3. Sulle tavole relative alle altre teste sono elencati tutti i particolari diversi o non montati sulla testa del Catalogo Base. Dette tavole portano in alto a destra il simbolo della testa cui si riferiscono (con indicato fra parentesi - nel caso di derivata - il simbolo della testa da cui deriva).  
I disegni di questo gruppo di tavole illustrano soltanto i pezzi nuovi o sostanzialmente diversi rispetto a quelli montati sulla testa più significativa del Catalogo.  
I particolari richiamati come simbolo, ma non illustrati, conservano lo stesso numero di figura dei corrispondenti raffigurati sul Catalogo base.  
I particolari comuni a tutte le teste comprese nel Catalogo, vengono richiamati soltanto nel primo gruppo di tavole.  
I particolari definiti come "pezzi annullati" si intendono quelli non montati sulla testa a cui la tavola si riferisce. Nel caso di un gruppo annullato, viene indicato soltanto il simbolo del gruppo, ma devono intendersi annullati anche tutti i particolari componenti il gruppo stesso.  
Per ogni testa viene sempre riportata interamente la tavola relativa agli organi di cucitura.

Per facilitare la ricerca viene riportato l'indice numerico di tutti i particolari illustrati sul Catalogo base, con la relativa tavola in cui gli stessi sono richiamati.

#### AGHI

Gli aghi sono contraddistinti dal sistema e dalla finezza, la quale indica il diametro medio espresso in centesimi di millimetro.

Il sistema dell'ago e la finezza sono marcati oltre che sulla busta, anche sull'ago stesso.

Nelle ordinazioni precisare, oltre il simbolo, il sistema e la finezza degli aghi desiderati. In caso di dubbio, allegare, un ago campione o una bustina vuota.

#### AVVERTENZA

Nella richiesta di parti di ricambio citare sempre il relativo numero di matricola della macchina, il simbolo del particolare e la denominazione ufficiale usata sul catalogo.

This spare parts catalogue is made up of two parts: in the first one, called "basic catalogue", all the details of most representative head are listed (the first head listed on the cover); the second one includes the details of the other main heads or derived ones, which are different from that of the basic catalogue.

The main heads are listed on the cover in bigger lettering to distinguish them from the derived heads.

When you consult the catalogue will you please note that:

1. all parts which cannot be supplied by themselves are not indicated alone, but shown together with the group to which they belong;
2. the references of the pictures of the parts making up the group are usually put in brackets.  
In some cases, however, when their grouping is not possible, the numbers of the various parts in the tables are marked with the same particular sign with which the whole group is indicated.
3. In the tables of the other heads there are listed all the parts not fitted on the head in the basic catalogue.  
These tables are marked at the top right hand corner with the symbol of the head which the table refers to.  
The drawings in this group of tables show only the parts which are new or basically different from those fitted on the most representative head in the catalogue.  
The parts which are represented only by the symbol but not illustrated keep the same figure number as the corresponding parts shown in the basic catalogue.  
The parts which are common to all the heads in the catalogue are listed only in the first group of tables.  
Parts marked "annulled part" are those not fitted on the head which the table refers to. When an assembly has been annulled only the assembly symbol is specified, but all the parts forming the assembly must also be considered annulled.  
For each head the table for sewing parts is always repeated completely.

To make it easier to locate the parts, the reference numbers of all of those shown in the basic catalogue are listed together with the number of the table in which they are to be found.

#### NEEDLES

The needles are marked with system and size; the size indicates the average diameter in hundredths of a millimeter.

The system and size of the needle are shown on the packet as well as on the needle itself. When ordering please state symbol, system and size. If you have doubts, enclose a sample needle or an empty packet with your order.

#### ATTENTION

When ordering spare parts always state the serial number of the machine, the symbol of the part in question and the description given in the catalogue.

Ce catalogue "pièces détachées" est formé de deux parties: la première appelée "catalogue base" comprend toutes les pièces montées sur la tête la plus significative (celle en tête de la liste de couverture), la seconde comprend toutes les pièces montées sur les autres têtes de base ou dérivées qui sont différentes de celle du "catalogue base".

Les têtes de base sont énumérées sur la couverture, en caractères plus grands que les têtes dérivées.

Lorsque l'on consulte le catalogue, se souvenir que:

1. Toutes les pièces qui ne sont pas fournies séparément mais qui font partie d'un groupe, ne sont pas indiquées séparément.
2. Les symboles des pièces qui forment un groupe sont regroupés entre parenthèses. Cependant, lorsque ceci n'a pas été possible, les symboles, qui dans les tables d'illustration correspondent aux pièces, sont suivis du même signe particulier qui indique le groupe tout entier.
3. Dans les tables relatives aux autres têtes, nous avons indiqué toutes les pièces différentes de celles de tête du "catalogue base" ou qui ne sont pas montées sur ces dernières. Ces tables portent, en haut à droite, le symbole des têtes auxquelles elles se réfèrent (pour les dérivées, le symbole de la tête de laquelle elles dérivent est indiqué entre parenthèses).  
Les dessins de ce groupe de tables représentent seulement les nouvelles pièces ou celles qui sont différentes des pièces montées sur la tête la plus significative du catalogue.  
Les pièces indiquées par un symbole, mais qui ne sont pas illustrées, gardent le même numéro de dessin que celles correspondantes, illustrées sur le catalogue base.  
Les pièces communes à toutes les têtes du catalogue, sont indiquées seulement dans le premier groupe de tables.  
Les pièces définies comme "pièces annulées" sont celles qui ne sont pas montées sur la tête à laquelle se réfère la table. Dans le cas de l'annulation d'un groupe, nous indiquons seulement le symbole du groupe, mais toutes les pièces qui forment ce groupe sont annulées.  
Pour chaque tête est toujours indiquée la table se référant aux organes de couture.

Pour faciliter la recherche, le catalogue renferme l'index numérique de toutes les pièces illustrées avec indication de la table dans laquelle elles sont indiquées.

#### AIGUILLES

Les aiguilles se différencient par le système et la grosseur, laquelle indique le diamètre moyen exprimé en centièmes de millimètre.

Le système de l'aiguille et sa grosseur, sont indiqués non seulement sur le sachet mais également sur l'aiguille.

Dans la commande, préciser, en plus du symbole, le système et la grosseur des aiguilles désirées. En cas de doute, joindre une aiguille comme modèle ou un sachet vide.

#### ATTENTION

Dans la commande de pièces détachées, indiquer toujours le numéro de la machine, le symbole de la pièce et la dénomination officielle mentionnée sur le catalogue.



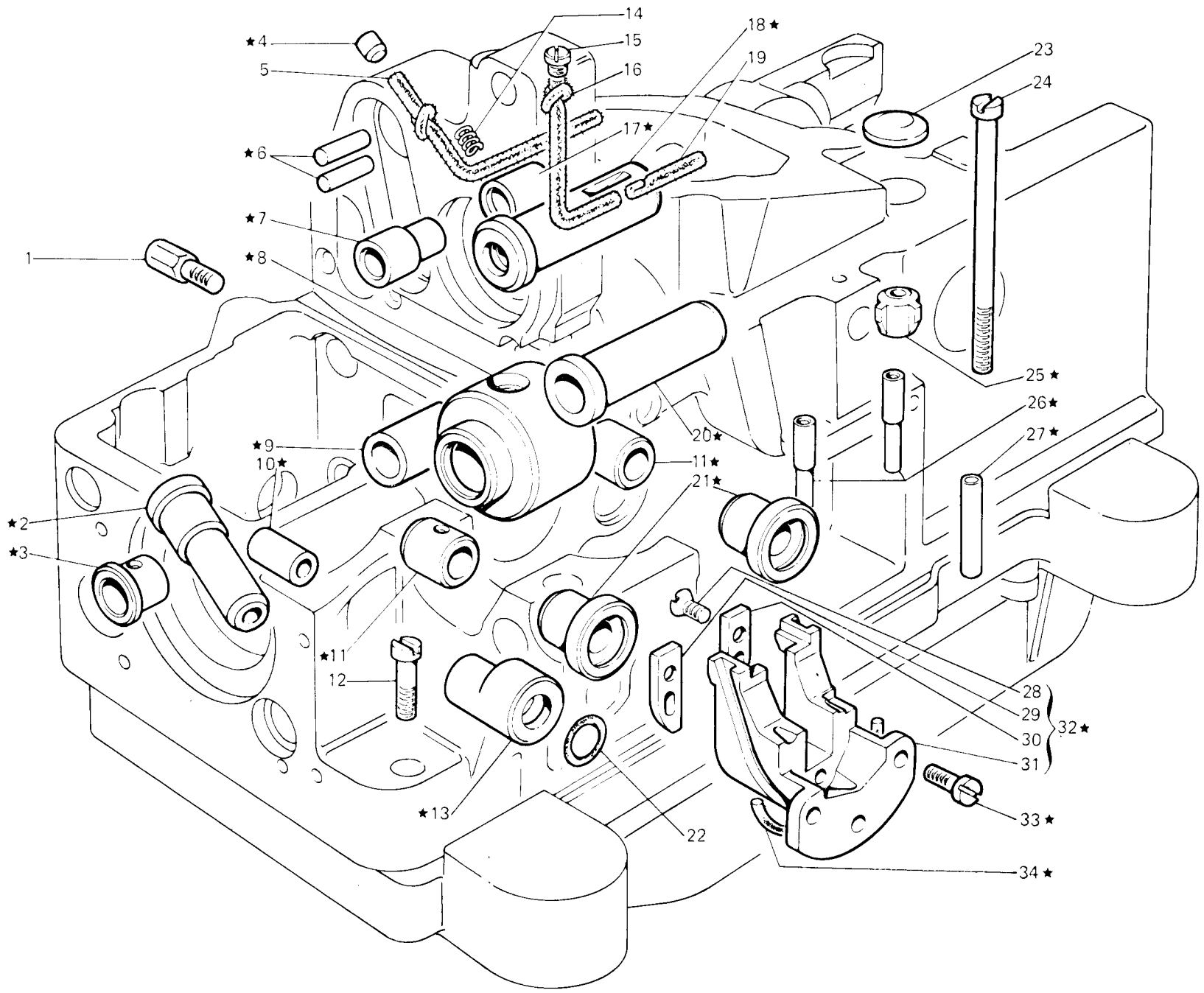

Fig. N. Abb. N.	Part. N. Piece N. Bestell N. Pieza N.	Qt. Anzahl	DESCRIZIONE	DESCRIPTION	DESCRIPTION	BENENNUNG	DESCRIPCION
★	208004-3-00	1	base con bussole e guidafili	base assembly	base complète		
1	204798-0-30	1	vite	screw	vis		
2	207707-0-01	1	guida pulsante	guide	guide		
3	206595-0-00	1	bussola sinistra	left bush	bage gauche		
4	301608-0-00	1	tappo	plug	bouchon		
5	778832-0-00	1	stoppino	wick	mèche		
6	202371-0-10	2	spina	pin	goupille		
7	207880-0-00	1	bussola	bush	bage		
8	206682-0-01	1	bussola intermedia	intermediary bush	bage intermédiaire		
9	206594-0-00	1	bussola	bush	bage		
10	207705-0-00	1	bussola	bush	bage		
11	206651-0-00	2	bussola posteriore	rear bush	bage arrière		
12	742086-2-00	1	vite	screw	vis		
13	207706-0-00	1	bussola	bush	bage		
14	208164-0-00	1	molla	spring	ressort		
15	742838-2-00	1	vite	screw	vis		
16	778833-0-00	1	stoppino	wick	mèche		
17	207879-0-00	1	bussola	bush	bage		
18	206538-0-00	1	bussola	bush	bage		
19	778417-0-00	1	stoppino	wick	mèche		
20	206539-0-00	1	bussola	bush	bage		
21	202065-0-20	2	bussola anteriore	front bush	bage-avant		
22	701011-0-00	1	anello di tenuta	retainer ring	bage d'étanchéité		
23	206748-0-00	1	tappo espansione	plug	bouchon		
24	207917-0-00	4	vite	screw	vis		
25	207758-0-01	1	bussola guida astina	bush	bage		
26	206740-0-00	2	passafilo	thread guide	passe-fil		
27	206296-0-00	1	tubetto scarica olio	pipe	tube		
28	744512-4-00	2	vite	screw	vis		
29	207945-0-00	1	piastrina	plate	plaque		
30	207947-0-00	1	piastrina	plate	plaque		
31	207943-2-00	1	guida	guide	guide		
32	207934-4-00	1	guida slitte completa	slides guide assembly	guide coulissant compl.		
33	722063-2-00	3	vite	screw	vis		
34	207948-0-00	1	guarnizione	gasket	garniture		

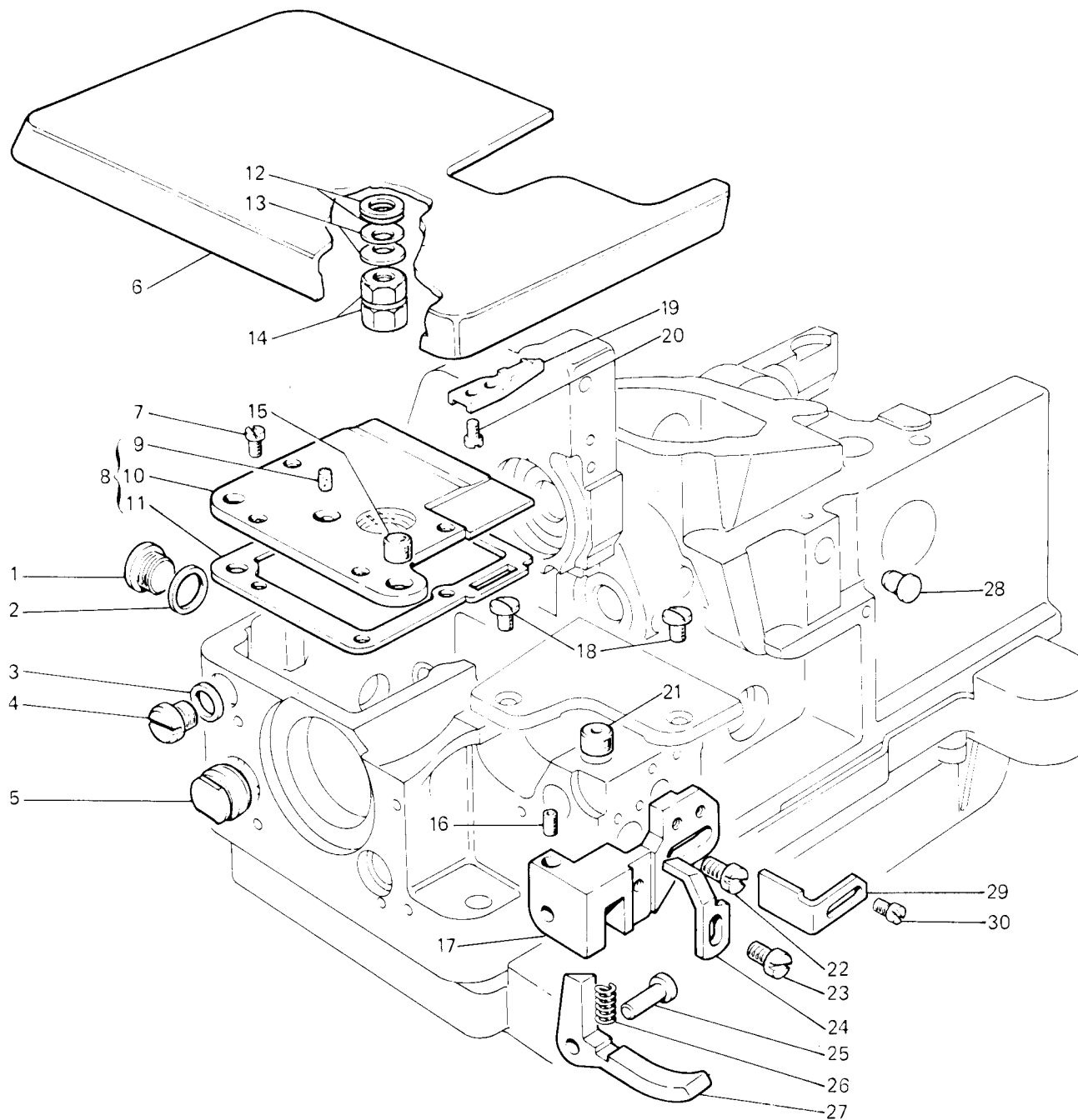



Fig. N. Abb. N.	Part. N. Bestell N. Piece N. Pieza N.	Qt. Anzahl	DESCRIZIONE	DESCRIPTION	DESCRIPTION	BENENNUNG	DESCRIPCION
1	202026-0-10	1	tappo	plug	bouchon		
2	705982-0-00	1	guarnizione	gasket	garniture		
3	705975-0-00	1	guarnizione	gasket	garniture		
4	202480-0-10	1	tappo	plug	bouchon		
5	202027-0-10	1	tappo	plug	bouchon		
6	207955-2-00	1	piano di lavoro	working plate	plan de travail		
7	722031-2-00	4	vite	screw	vis		
8	207951-4-00	1	coperchio completo	cover assembly	couvercle complet		
9	778241-0-00	1	stoppino	wick	mèche		
10	207952-2-00	1	coperchio	cover	couvercle		
11	207953-0-00	1	guarnizione	gasket	garniture		
12	704428-2-00	2	rondella	washer	rondelle		
13	702415-0-00	2	molla a tazza	cup spring	ressort à tasse		
14	208165-0-00	2	dado	nut	écrou		
15	207954-0-00	1	tappo	plug	bouchon		
16	729022-2-00	1	vite	screw	vis		
17	207981-0-00	1	supporto sgancio piano di lavoro	support	support		
18	744742-0-00	2	vite fissa placca ago	screw	vis		
19	207985-0-00	1	gancio arresto piano di lavoro	hook	crochet		
20	741936-2-00	2	vite	screw	vis		
21	207958-0-00	1	tappo	plug	bouchon		
22	741963-0-00	2	vite	screw	vis		
23	741658-2-00	1	vite	screw	vis		
24	207988-0-00	1	squadretta	bracket	équerre		
25	207980-0-00	1	perno	pin	pivot		
26	307137-0-00	1	molla	spring	ressort		
27	207983-0-00	1	leva per sgancio	lever	levier		
28	202398-0-10	1	tappo	plug	bouchon		
29	207984-0-00	1	squadretta	bracket	équerre		
30	721412-2-00	2	vite	screw	vis		

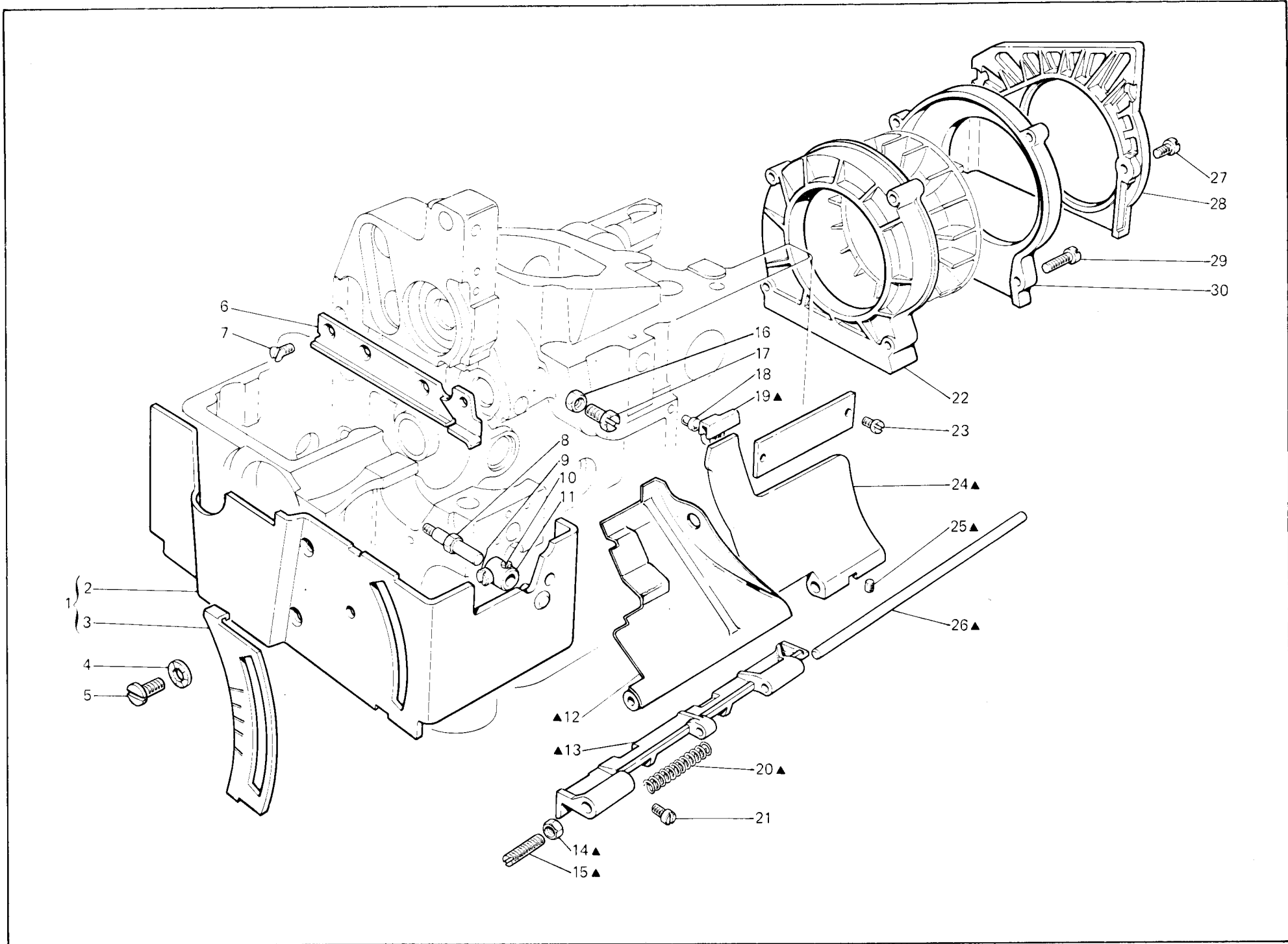

Fig. N. Abb. N.	Part. N. Pezce N. Bestell N. Pieza N.	Qt. Anzahl	DESCRIZIONE	DESCRIPTION	DESCRIPTION	BENENNUNG	DESCRIPCION
▲	208061-4-00	1	sportello anteriore completo	front cover assembly		carter avant complet	
1	208029-4-00	1	carter laterale completo	side cover assembly		carter latéral complet	
2	208028-2-00	1	carter laterale	side cover		carter latéral	
3	206797-0-00	1	piastrina	plate		plaque	
4	703405-0-00	4	rondella elastica	spring washer		rondelle élastique	
5	724895-2-00	4	vite	screw		vis	
6	207961-0-00	1	carterino	carter		carter	
7	744634-2-00	3	vite	screw		vis	
8	206733-0-01	1	vite per carter laterale	screw		vis	
9	721435-2-00	1	vite	screw		vis	
10	730023-2-00	1	vite	screw		vis	
11	206734-2-00	1	morsetto con viti	clamp with screws		collier de serrage avec vis	
12	206884-2-01	1	sportello scorrevole	sliding cover		carter coulissant	
13	206756-0-01	1	cerniera	hinge		charnière	
14	746208-2-00	1	dado	nut		écrou	
15	206769-0-10	1	vite di regolazione	adjustment screw		vis de réglage	
16	746007-2-00	1	dado	nut		écrou	
17	202214-0-11	1	vite	screw		vis	
18	207856-0-00	1	gommino	dumper		caoutch	
19	206764-0-00	1	zoccolo	block		socle	
20	206768-0-00	1	molla	spring		ressort	
21	741724-0-00	4	vite	screw		vis	
22	206688-0-00	1	coclea per ventola	scroll		palier	
23	202165-0-10	2	vite	screw		vis	
24	207858-0-00	1	sportello ribaltabile	tipping cover		carter amovible	
25	745800-2-00	1	vite	screw		vis	
26	206767-0-00	1	perno	pin		pivot	
27	722063-2-00	1	vite per coperchio	screw		vis	
28	206685-0-00	1	coperchio cinghia	cover		couvercle	
29	202484-0-10	4	vite	screw		vis	
30	206687-2-00	1	coperchio coclea	scroll cover		couvercle palier	

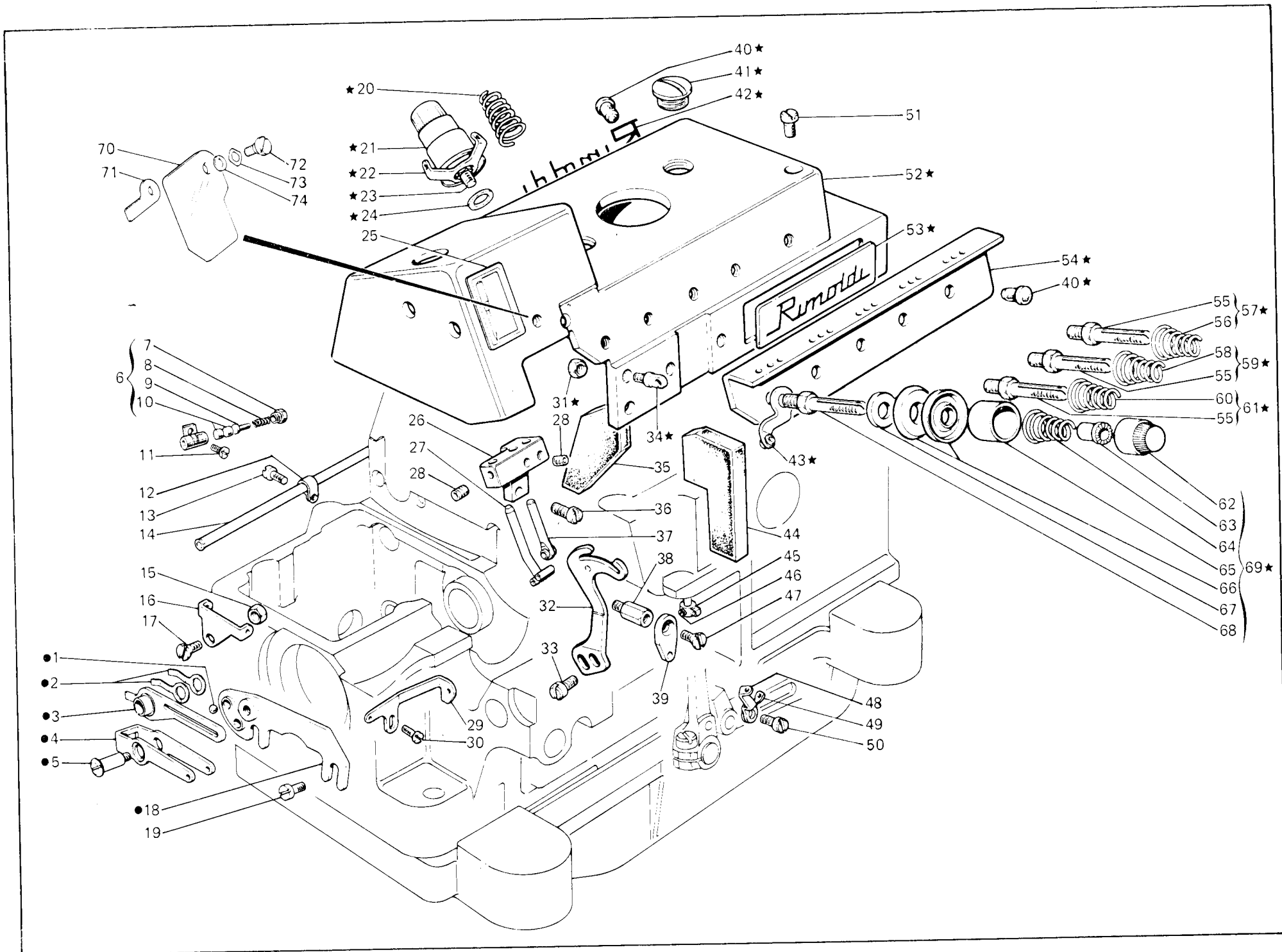

Fig. N. Abb. N.	Part. N. Bestell N. Piece N. Pieza N.	Qt. Anzahl	DESCRIZIONE	DESCRIPTION	DESCRIPTION	BENENNUNG	DESCRIPCION
●	206091-4-02	1	gruppo passafili per camma	thread guide assembly for cam	groupe passe-fils pour came		
★	208107-4-00	1	coperchio superiore completo	upper cover assembly	couvercle supérieur complet		
1	707602-0-00	1	sfera	ball	sphère		
2	207224-0-10	2	molla	spring	ressort		
3	207221-2-10	1	passafilo	thread guide	passe-fil		
4	206090-0-10	1	passafilo laterale	side thread guide	passe-fil latéral		
5	207225-0-10	1	vite	screw	vis		
6	207551-4-00	1	pressafilo compl. dell'ago	thread presser assembly	presse-fil complet		
7	202260-0-10	1	tappo	plug	bouchon		
8	202257-0-10	1	molla	spring	ressort		
9	202258-0-10	1	perno	pin	pivot		
10	203635-0-10	2	pastiglia	plug	bouchon		
11	207562-0-00	1	vite	screw	vis		
12	204756-0-10	1	fascetta	clamp	bride		
13	741559-2-00	1	vite	screw	vis		
14	204704-0-10	1	tubetto	pipe	tube		
15	733505-2-00	1	dado	nut	écrou		
16	204747-0-10	1	passafilo	thread guide	passe-fil		
17	724422-2-00	1	vite	screw	vis		
18	207219-0-10	1	supporto	support	support		
19	721424-2-00	2	vite	screw	vis		
20	203457-0-10	1	molla per tensione fig.21	spring for tension fig.21	ressort pour tension fig. 21		
21	206340-4-00	1	tensione completa con fig.20-23	tension assembly with fig.20-23	tension complète avec fig.20-23		
22	308503-0-01	1	passafilo	thread guide	passe-fil		
23	202225-0-11	1	perno per tensione fig. 21	pin for tension fig. 21	pivot pour tension fig. 21		
24	705013-0-00	1	rondella	washer	rondelle		
25	788001-0-01	1	decalcomania sist. aghi	syst. needles decalcomania	décalcomanie syst. aiguilles		
26	207916-0-00	1	supporto passafili aghi	support	support		
27	203647-2-13	1	passafilo ago	thread guide of needle	passe-fil de l'aiguille		
28	745800-2-00	2	vite	screw	vis		
29	206876-0-01	1	passafilo	thread guide	passe-fil		
30	741642-2-00	1	vite	screw	vis		
31	733503-0-00	3	dado	nut	écrou		
32	207873-0-00	1	tendifilo ago	needle thread guide	tendeur du fil aiguille		
33	741558-0-00	2	vite	screw	vis		
34	206711-0-00	3	passafilo	thread guide	passe-fil		
35	207891-0-00	1	filtro	filter	filtre		
36	741956-2-00	2	vite	screw	vis		
37	208184-2-00	1	passafilo completo	thread guide assembly	passe-fil complet		
38	206755-0-00	1	colonnina per passafilo	threaded tube	tube pour passe-fil		
39	206812-0-00	1	passafilo crochet superiore	thread guide for upper looper	passe-fil pour crochet supérieur		
40	207893-0-00	2	tappo	plug	bouchon		
41	207968-0-00	2	tappo	plug	bouchon		
42	100305-0-10	1	decalcomania	decalcomania	décalcomanie		
43	206713-2-00	1	passafilo	thread guide	passe-fil		
44	207890-0-00	1	filtro	filter	filtre		
45	203135-2-10	1	passafilo	thread guide	passe-fil		
46	745002-0-00	1	vite	screw	vis		
47	744631-2-00	1	vite	screw	vis		

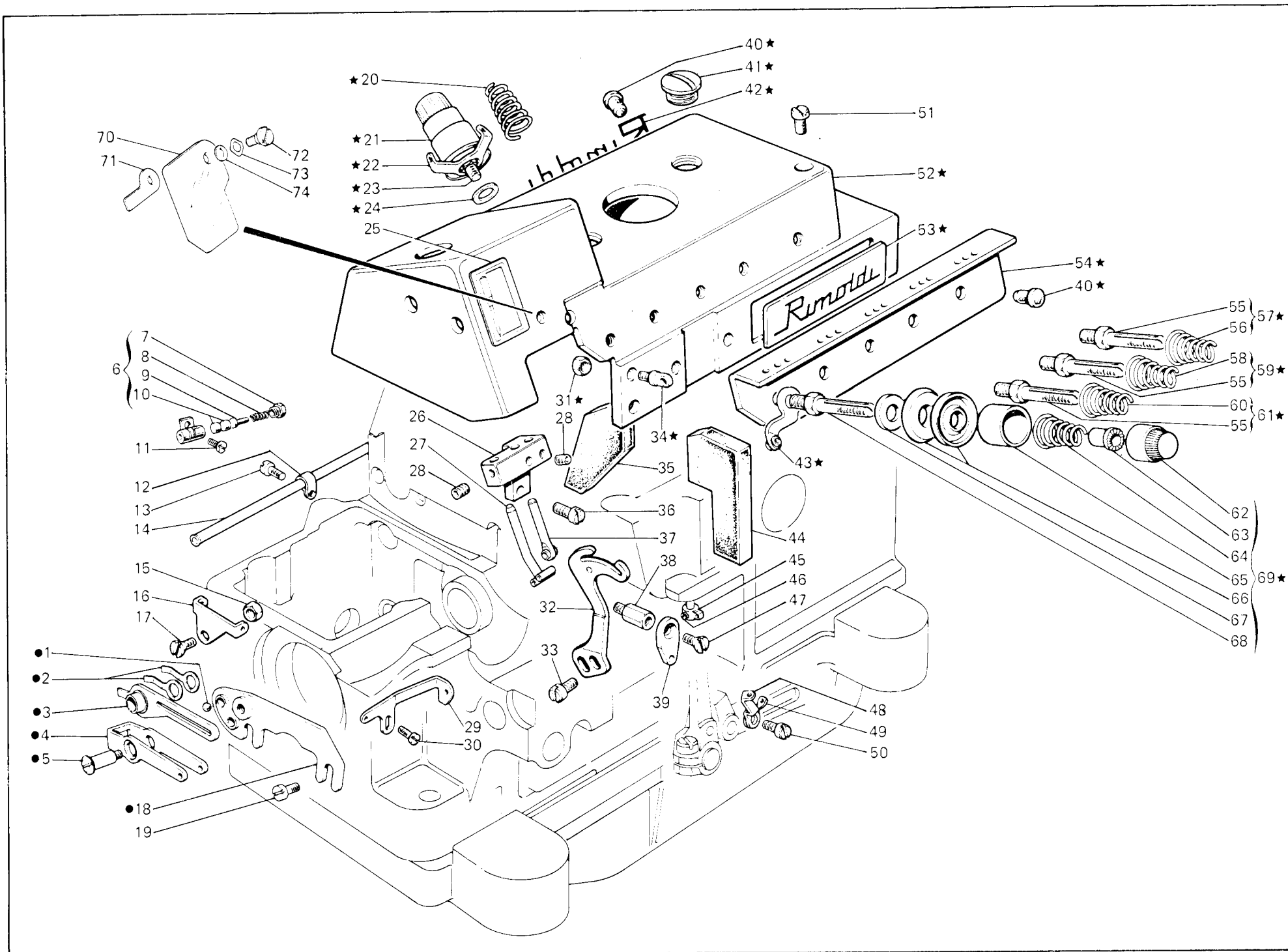

Fig. N. Abb. N.	Part. N. Piece N. Bestell N. Pieza N.	Qt. Anzahl	DESCRIZIONE	DESCRIPTION	DESCRIPTION	BENENNUNG	DESCRIPCION
48	202279-0-10	1	tendifilo	thread take-up	tendeur du fil		
49	202281-0-10	1	passafilo	thread guide	passe-fil		
50	741675-0-00	1	vite	screw	vis		
51	721484-2-00	3	vite fissa coperchio superiore	screw	vis		
52	207910-0-00	1	coperchio superiore	upper cover	couvercle supérieur		
53	207918-0-00	1	targhetta	plate	plaque		
54	207919-0-00	1	piastra passafili	thread guide plate	plaque pour passe-fil		
55	206747-0-01	3	perno	pin	pivot		
56	202227-0-10	1	molla	spring	ressort		
57	206341-4-00	1	tensione compl.	tension assembly	tension complète		
58	202681-0-10	1	molla	spring	ressort		
59	206343-4-00	1	tensione completa	tension assembly	tension complète		
60	202228-0-10	1	molla	spring	ressort		
61	206342-4-00	1	tensione completa	tension assembly	tension complète		
62	202558-2-00	5	pomolo	knob	pommeau		
63	202229-0-10	5	bussola	bush	bague		
64	202227-0-10	1	molla	spring	ressort		
65	202556-0-10	5	scodellino	cup	cuvette		
66	300218-0-10	10	disco tensione	tension disc	disque tension		
67	206754-0-00	5	rondella	washer	rondelle		
68	208169-0-00	1	perno	pin	pivot		
69	208172-4-00	1	tensione compl.	tension assembly	tension compl.		
70	208221-0-00	1	piastrina protezione	plate	plaque		
71	208222-0-00	1	piastrina	plate	plaque		
72	208224-0-00	1	vite	screw	vis		
73	208220-0-00	1	anello elastico	spring ring	anneau ressort		
74	704630-0-00	1	rondella	washer	rondelle		
			SOLO A RICHIESTA	ONLY ON REQUEST	SEULEMENT SUR DEMANDE		
—	208311-4-00	1	gruppo passafili compl.	thread guide assembly	groupe passe-fil		
27	208197-3-00	1	passafili aghi	needles thread guide	passe-fils aiguilles		
31	733503-0-00	3	dado	nut	écrou		
34	208204-2-00	3	passafilo	thread guide	passe-fil		
37	208179-2-00	1	passafilo	thread guide	passe-fil		
43	208185-2-00	1	passafilo	thread guide	passe-fil		

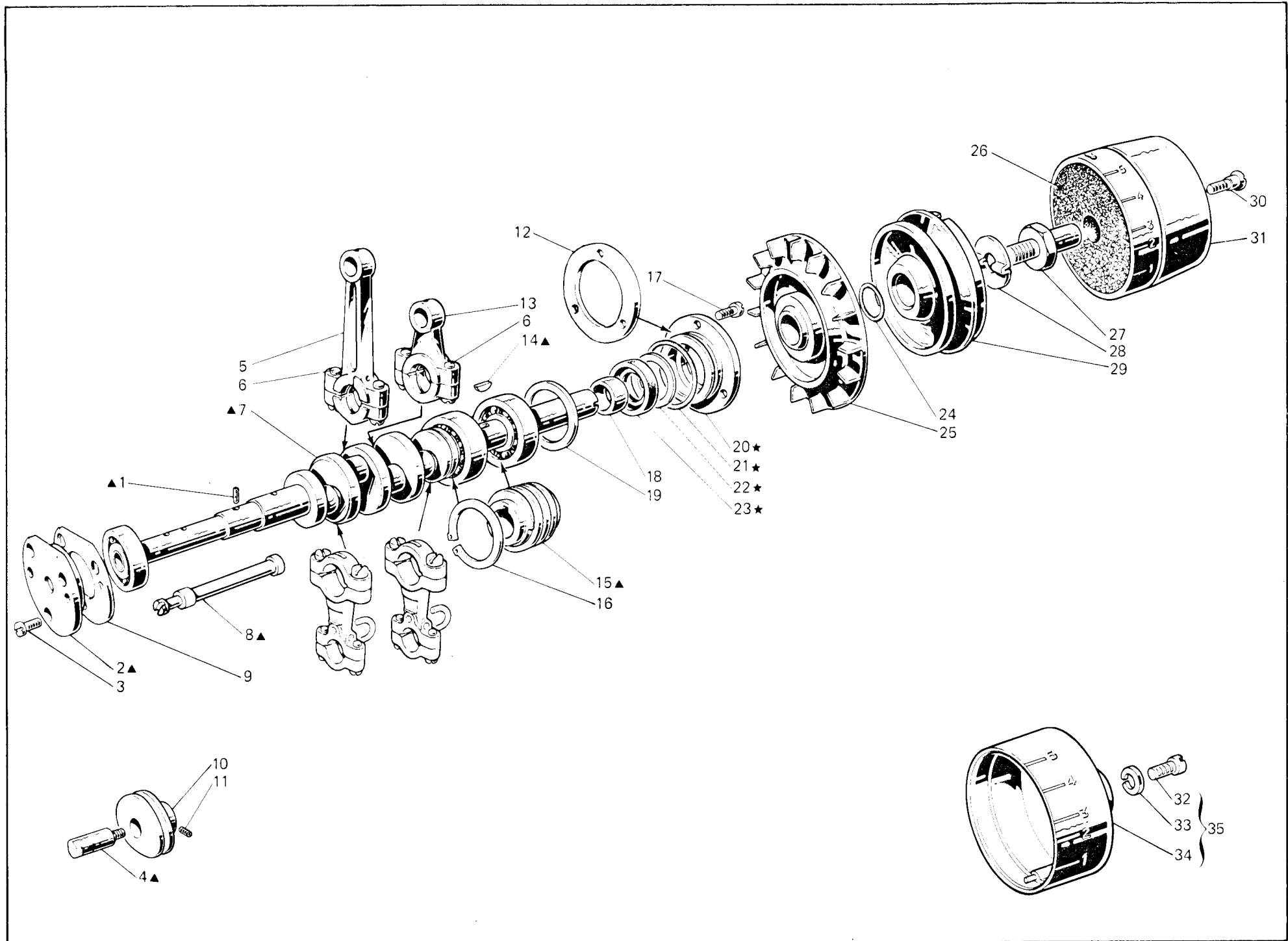



Fig. N. Abb. N.	Part. N. Bestell N. Piecce N. Pieza N.	Qt. Anzahl	DESCRIZIONE	DESCRIPTION	DESCRIPTION	BENENNUNG	DESCRIPCION
▲	206970-4-01	1	albero princ.con cuscinetti	main shaft	arbre principale		
★	206697-4-01	1	gruppo flangia con anelli	flange with ring assembly	groupe flasque avec bague		
1	206708-0-00	1	stoppino	wick	mèche		
2	206860-0-00	1	flangia sinistra	left flange	flasque gauche		
3	741956-2-00	3	vite	screw	vis		
4	204757-0-11	1	perno porta camma	pin	pivot		
5	206549-2-00	1	biella albero sup.con vite	connecting rod with screw	bielle arbre sup.avec vis		
6	743471-2-00	4	vite	screw	vis		
7	206702-2-01	1	albero principale	main shaft	arbre principale		
8	206974-0-00	1	limitatore olio	oil limiter	limitateur d'huile		
9	206543-0-01	1	guarnizione	gasket	garniture		
10	207167-2-00	1	camma tendifilo con viti	thread guide with screws	came tendeur du fil avec vis		
11	727203-0-00	2	vite	screw	vis		
12	206544-0-00	1	guarnizione	gasket	garniture		
13	206578-2-00	1	biella com.alb.colt.super.	connecting rod for upper knife	bielle comm.arbre couteau sup.		
14	204122-0-10	1	chiavetta	key	clavette		
15	206556-0-01	1	vite senza fine	wom screw	vis sans fin		
16	202386-0-10	1	anello elastico	spring ring	anneau ressort		
17	722063-2-00	3	vite	screw	vis		
18	206692-0-00	1	distanziale albero principale	spacer	entretoise		
19	206689-0-01	1	anello compensazione	ring	anneau		
20	206699-0-01	1	flangia	flange	flasque		
21	701133-0-00	1	anello di tenuta	circlip	circlip		
22	206693-0-0	1	rondella	washer	rondelle		
23	700630-0-00	1	anello di tenuta	circlip	circlip		
24	701116-0-00	1	anello di tenuta	circlip	circlip		
25	206690-2-00	1	ventola di raffreddamento	cooling fan	ventilateur		
26	206507-0-00	1	tampone per volante	pad	tampon		
27	206683-0-00	1	perno volante	pin	pivot		
28	206684-0-00	1	chiavetta albero principale	key	clavette		
29	206508-0-00	1	volantino	pulley	volant		
30	202492-0-10	1	vite	screw	vis		
31	206679-0-00	1	coperchio volante	pulley cover	couvercle volant		
			SQLO A RICHIESTA	ONLY ON REQUEST	SEULEMENT SUR DEMANDE		
29	207140-0-00	1	volantino	pulley	volant		
32	721525-0-00	1	vite	screw	vis		
33	703007-0-00	1	rondella	washer	rondelle		
34	202352-2-11	1	calotta volante	handwheel cover	couvercle volant		
35	202539-4-00	1	calotta vol.per Quick-Stop	handwheel cover for Quick-Stop	couvercle volant pour Quick-Stop		

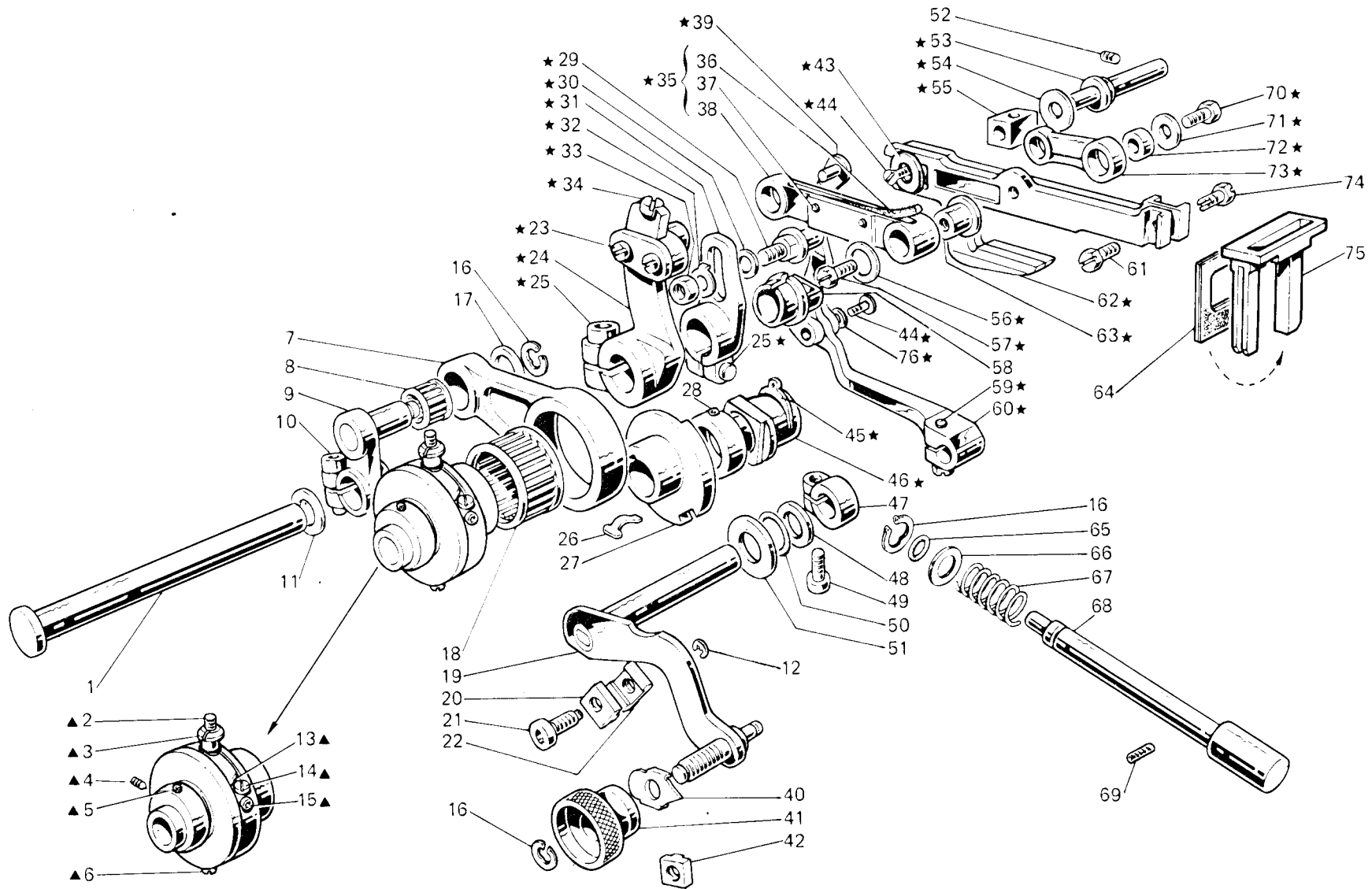

Fig. N. Abb. N.	Part. N. Piece N. Bestell N. Pieza N.	Qt. Anzahl	DESCRIZIONE	DESCRIPTION	DESCRIPTION	BENENNUNG	DESCRIPCION
★	208098-4-00	1	gruppo comando griffa	feed dog control assembly	groupe commande griffe		
▲	207698-4-00	1	gruppo eccentr.regol.trasporto	eccentric group	groupe excentrique		
1	206593-0-00	1	contralbero trasporto	transport countershaft	axe-transport		
2	729051-2-00	1	vite	screw	vis		
3	206603-0-10	1	fermo eccentrico	eccentric retainer	pièce blocage excentrique		
4	745815-2-00	1	vite	screw	vis		
5	778401-0-00	1	stoppino	wick	mèche		
6	727884-0-00	1	vite	screw	vis		
7	206599-0-01	1	biella comando trasporto	transport con-rod control	bielle commande transport		
8	201358-0-10	1	gabbia a rullini	needles cage	cage à aiguilles		
9	206598-3-00	1	braccio a manovella con vite	crank arm with screw	bras à manivelle avec vis		
10	744334-2-00	1	vite	screw	vis		
11	704841-0-00	1	rondella	washer	rondelle		
12	700206-2-00	2	anello elastico	spring ring	anneau ressort		
13	202412-0-11	1	lardone	gib	lardon		
14	202473-0-11	2	vite	screw	vis		
15	730011-2-00	2	vite	screw	vis		
16	700207-0-00	3	anello elastico	spring ring	anneau ressort		
17	206546-0-00	1	rondella	washer	rondelle		
18	202385-0-10	1	gabbia a rullini	needles cage	cage à aiguille		
19	206790-2-10	1	leva comando slitta	lever	levier		
20	206799-0-00	1	arresto regolabile esterno	external retainer	butée réglable externe		
21	206875-0-00	2	vite	screw	vis		
22	206795-0-00	2	arresto regolabile interno	internal retainer	butée réglable interne		
23	741546-2-00	2	vite	screw	vis		
24	206592-3-00	1	manovella trasporto con viti	transport crank with screw	manivelle transport avec vis		
25	744332-2-00	2	vite	screw	vis		
26	206872-0-00	1	molla	spring	ressort		
27	206605-0-01	1	eccentrico	eccentric	excentrique		
28	207717-2-00	1	eccentrico con viti	eccentric with screws	excentrique avec vis		
29	202063-0-10	1	spina	pin	goupille		
30	704808-0-00	1	rondella	washer	rondelle		
31	206584-2-00	1	braccio manovella	crank arm	bras à manivelle		
32	206580-2-00	1	rondella con spina	washer with pin	rondelle avec goupille		
33	746008-0-00	1	dado	nut	écrou		
34	741413-0-00	1	vite	screw	vis		
35	206615-4-00	1	biellino completo	con-rod assembly	petite bielle complète		
36	778417-0-00	1	stoppino	wick	mèche		
37	200490-0-00	2	spillo	needle	épingle		
38	206587-0-00	1	biellino	con-rod	petite bielle		
39	745812-2-00	2	vite	screw	vis		
40	206796-0-00	1	indice rapp. differ.	differential index	indice différentiel		
41	206798-0-00	1	bottono rapp. differenziale	differential button	bouton différentiel		
42	206794-0-00	1	arresto regolabile esterno	external retainer	butée réglable externe		
43	202475-0-10	1	rondella	washer	rondelle		
44	724032-0-00	1	vite	screw	vis		
45	201610-0-01	1	anello elastico	spring ring	anneau ressort		
46	206617-0-00	1	blocchetto	block	bloc		
47	100620-2-10	1	morsetto con vite	clamp with screw	collier de serrage avec vis		

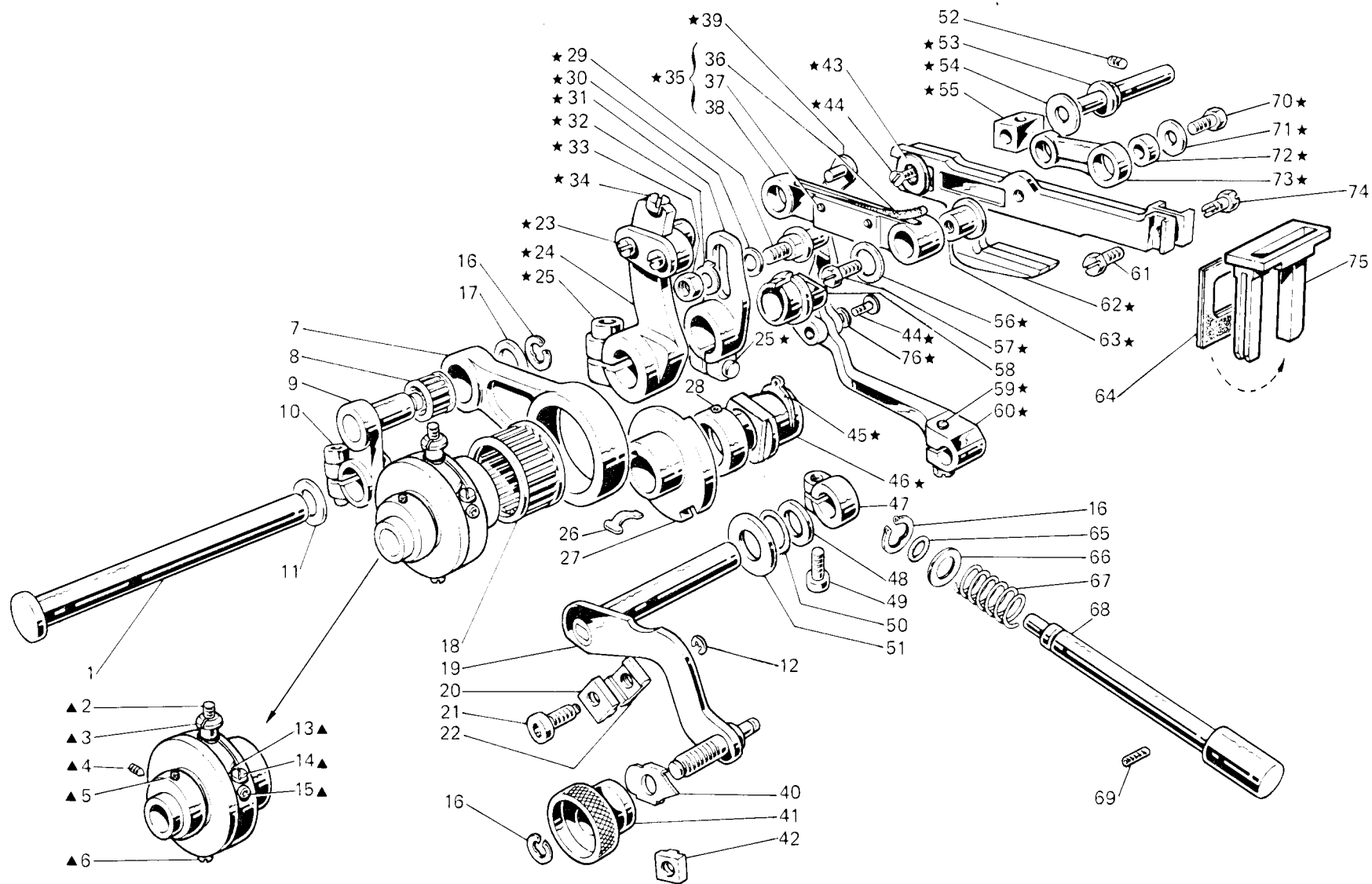

Fig. N. Abb. N.	Part. N. Piecce N. Bestell N. Pieza N.	Qt. Anzahl	DESCRIZIONE	DESCRIPTION	DESCRIPTION	BENENNUNG	DESCRIPCION
48	704829-0-00	1	rondella	washer	rondelle		
49	741745-2-00	1	vite	screw	vis		
50	701007-0-00	1	anello di tenuta	circlip	circlip		
51	705230-0-00	1	rondella	washer	rondelle		
52	202478-0-10	1	vite	screw	vis		
53	206613-0-00	1	perno eccentrico	eccentric pin	pivot excentrique		
54	705408-0-00	1	rondella	washer	rondelle		
55	202033-0-10	1	biocchetto	block	bloc		
56	705008-0-00	1	rondella	washer	rondelle		
57	206588-0-00	1	vite	screw	vis		
58	206619-0-00	1	vaschetta olio	oil sump	cuvette huile		
59	740053-2-00	1	vite	screw	vis		
60	207712-3-00	1	braccio regol. differenziale	differential arm	bras différentiel		
61	202489-0-10	1	vite	screw	vis		
62	207942-3-00	1	gruppo slitta porta griffe	feed dog slide group	groupe glissière porte-griffe		
63	206586-0-01	1	bussola per biellino	bush	bague		
64	207944-0-00	2	guarnizione raschia olio	oil scraper gasket	garniture râcheur d'huile		
65	701004-0-00	1	anello	ring	anneau		
66	704314-2-00	1	rondella	washer	rondelle		
67	202408-0-10	1	molla	spring	ressort		
68	206618-0-10	1	pulsante reg. punto	bush-button	poussoir réglable point		
69	729032-2-00	1	vite	screw	vis		
70	202490-0-10	1	vite	screw	vis		
71	705208-0-00	1	rondella	washer	rondelle		
72	202032-0-11	1	bussolina	bush	bague		
73	206583-0-00	1	biellino	con-rod	petite bielle		
74	202488-0-10	1	vite	screw	vis		
75	207946-0-00	1	telaio raschia olio	oil scraper frame	râcheur d'huile		

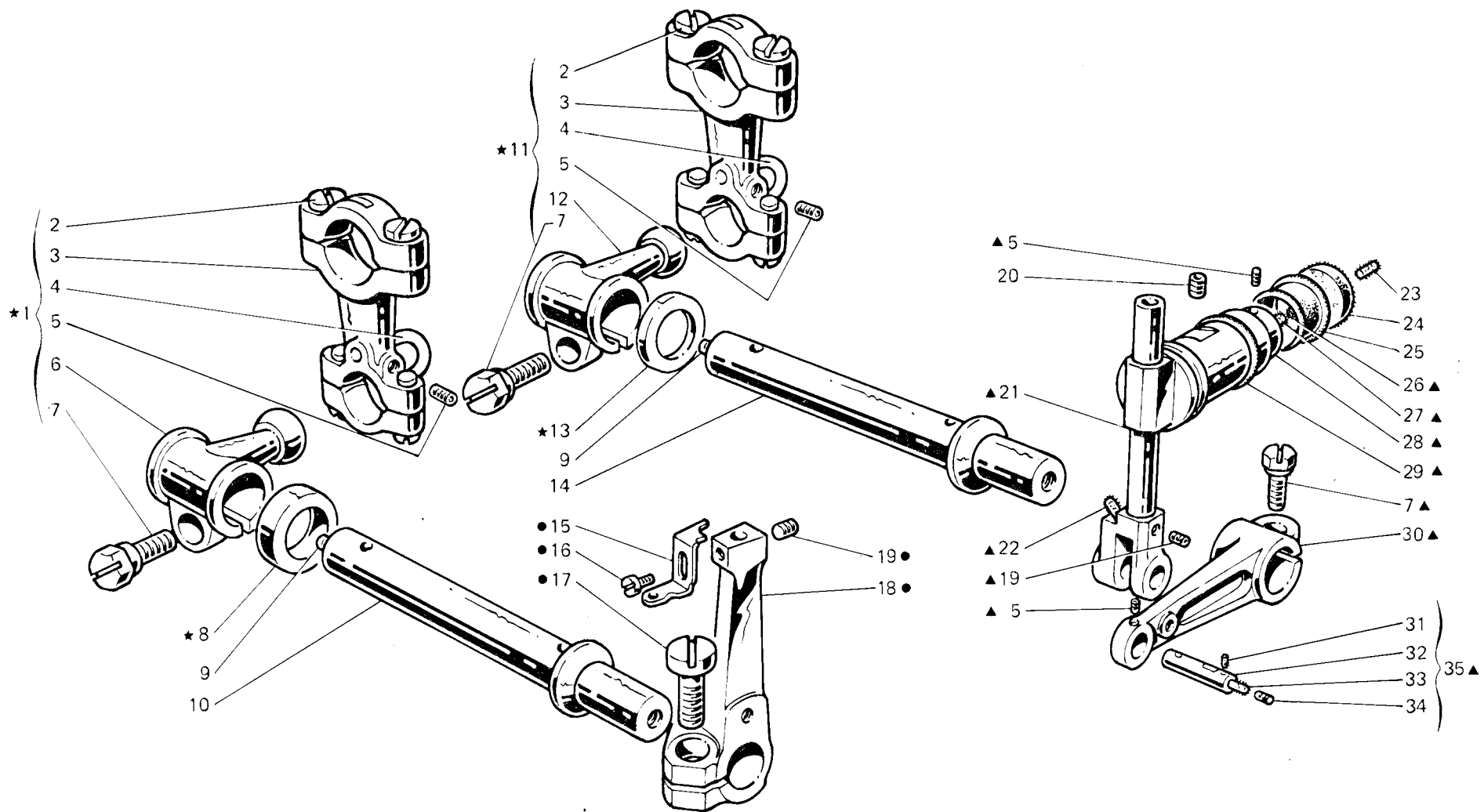

Fig. N. Abb. N.	Part. N. Pezza N. Bestell N. Pieza N.	Ct. Anzahl	DESCRIZIONE	DESCRIPTION	DESCRIPTION	BENENNUNG	DESCRIPCION
★	206386-4-00	1	gruppo manicotti com.crochet	looper control coupling assembly	groupe manchon comm,crochet		
▲	206415-4-00	1	gruppo comando crochet superiore	upper looper control assembly	groupe commande crochet supérieur		
●	208039-4-00	1	gruppo porta crochet inferiore	lower looper assembly	groupe porte crochet inférieur		
1	206453-4-00	1	gruppo manicotto con biella	coupling assembly with con-rod	groupe manchon avec bielle		
2	743243-2-00	8	vite per biella	screw	vis		
3	202071-2-20	2	biella con viti	con-rod with screw	bielle avec vis		
4	206643-0-01	2	cavallotto	coupling	cavalier		
5	745812-2-00	4	vite	screw	vis		
6	206659-2-01	1	manicotto	coupling	manchon		
7	201128-0-10	3	vite	screw	vis		
8	704847-0-00	1	rondella	washer	rondelle		
9	206695-0-00	2	tappo per albero	plug for shaft	bouchon pour arbre		
10	207096-2-00	1	albero crochet inferiore	shaft lower looper	arbre crochet inférieur		
11	206452-4-00	1	gruppo manicotto con biella	coupling with con-rod	groupe manchon avec bielle		
12	206658-2-02	1	manicotto	coupling	manchon		
13	704845-0-00	1	rondella	washer	rondelle		
14	207095-2-00	1	albero crochet superiore	upper looper shaft	arbre crochet supérieur		
15	208015-0-00	1	squadretta	bracket	équerre		
16	741415-0-00	1	vite	screw	vis		
17	721883-0-00	1	vite	screw	vis		
18	206654-2-10	1	porta crochet inf.	lower looper holder	porte crochet inférieur		
19	745800-2-00	2	vite	screw	vis		
20	745168-0-00	1	vite	screw	vis		
21	206410-3-00	1	guida oscillante	oscillating guide	guide oscillant		
22	778403-0-00	1	stoppino	wick	mèche		
23	778236-0-00	1	stoppino	wick	mèche		
24	206686-0-00	1	disco lubrificazione guida	disc	disque		
25	202720-0-00	1	paraolio	oil retainer	pare-huile		
26	778405-0-00	1	stoppino	wick	mèche		
27	778410-0-00	1	stoppino	wick	mèche		
28	202062-2-10	1	anello con vite	ring with screw	anneau avec vis		
29	701113-0-00	1	anello di tenuta	circlip	circlip		
30	206652-2-01	1	braccio	arm	bras		
31	778202-0-00	4	stoppino	wick	mèche		
32	202086-0-11	1	spina	pin	goupille		
33	778401-0-00	1	stoppino	wick	mèche		
34	745002-0-00	1	vite	screw	vis		
35	206645-4-01	1	spina completa	pin assembly	goupille compl.		

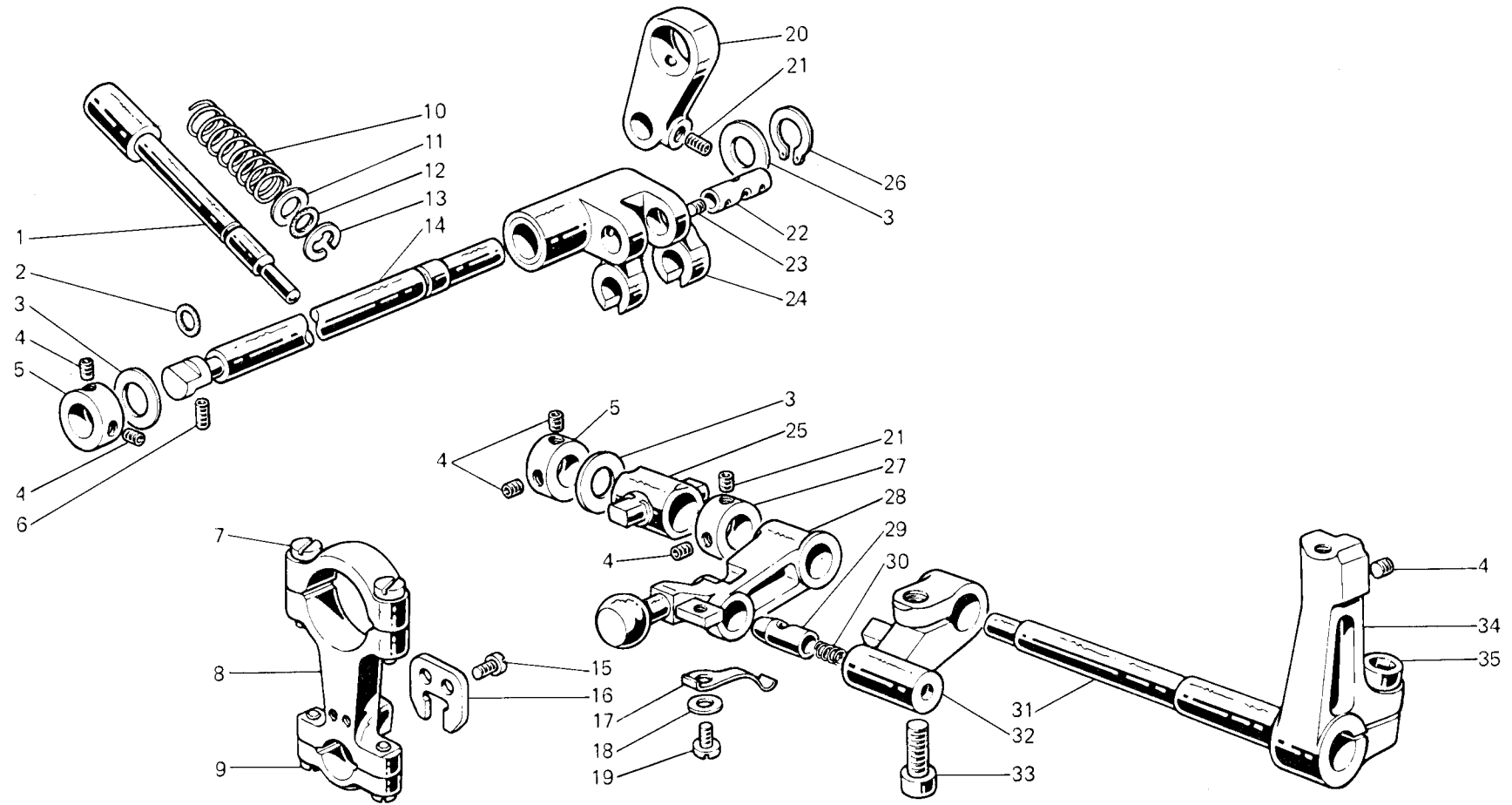



Fig. N. Abb. N.	Part. N. Bestell N. Piece N. Pieza N.	Qt. Anzahl	DESCRIZIONE	DESCRIPTION	DESCRIPTION	BENENNUNG	DESCRIPCION
1	207708-0-00	1	pulsante	push-button	poussoir		
2	701007-0-00	1	anello di tenuta	retainer ring	bague d'étanchéité		
3	704825-0-00	3	rondella	washer	rondelle		
4	745812-2-00	6	vite	screw	vis		
5	207692-2-00	2	anello di registro	adjustment ring	bague de réglage		
6	729032-2-00	1	vite	screw	vis		
7	721514-0-00	2	vite	screw	vis		
8	207699-2-00	1	biella comando crochet	looper control con-rod	bielle commande crochet		
9	743243-2-00	2	vite	screw	vis		
10	311069-0-00	1	molla	spring	ressort		
11	704314-2-00	1	rondella	washer	rondelle		
12	701004-0-00	1	anello di tenuta	retainer ring	bague d'étanchéité		
13	700207-0-00	1	anello elastico	spring ring	anneau ressort		
14	207690-0-00	1	perno	pin	pivot		
15	741558-0-00	2	vite	screw	vis		
16	207700-0-00	1	forcellino	fork	fourche		
17	207702-0-00	1	molla	spring	ressort		
18	704205-2-00	1	rondella	washer	rondelle		
19	741620-2-00	1	vite	screw	vis		
20	207686-0-00	1	biellino	con-rod	petite bielle		
21	730022-2-00	2	vite	screw	vis		
22	207687-0-00	1	spinotto	pin	goupille		
23	745002-0-00	1	vite	screw	vis		
24	207688-2-00	1	leva con bussole	lever with bush	levier avec bague		
25	207691-0-00	1	crociera	coupling	croisière		
26	700008-0-00	1	anello elastico	spring ring	anneau ressort		
27	207693-2-00	1	anello di registro	adjustment ring	bague de réglage		
28	207701-0-00	1	leva comando crochet	lever for looper control	levier commande crochet		
29	304172-0-10	1	perno	pin	pivot		
30	304195-0-10	1	molla	spring	ressort		
31	207704-0-00	1	albero porta crochet	looper shaft	arbre porte crochet		
32	207703-2-00	1	manicotto con vite	coupling with screw	manchon avec vis		
33	722443-2-00	1	vite	screw	vis		
34	207721-2-00	1	porta crochet con viti	looper holder with screws	porte crochet avec vis		
35	722433-2-00	1	vite	screw	vis		

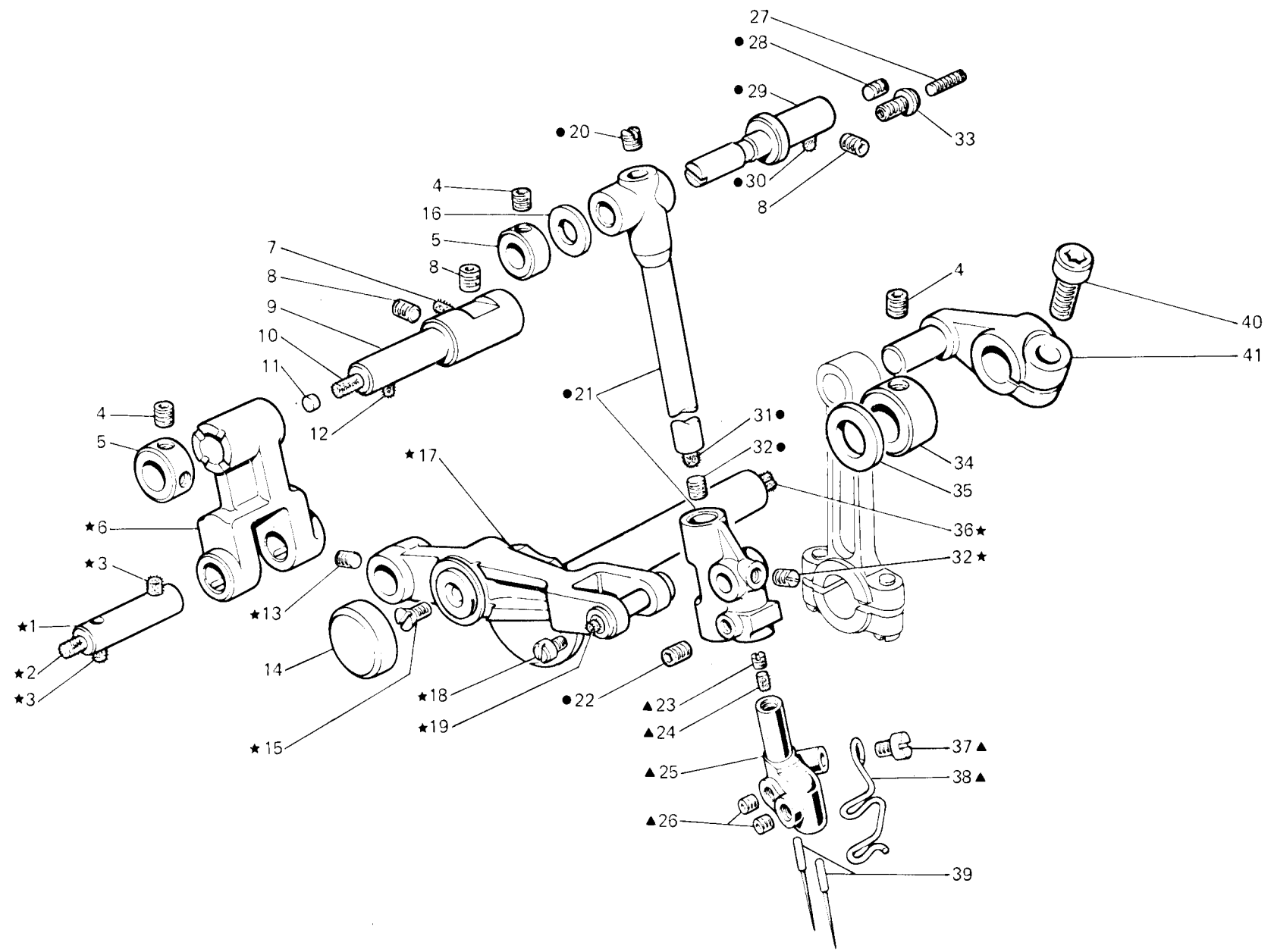

Fig. N. Abb. N.	Part. N. Piecce N. Bestell N. Pieza N.	Qt. Anzahl	DESCRIZIONE	DESCRIPTION	DESCRIPTION	BENENNUNG	DESCRIPCION
★	208140-4-01	1	cinematismo comando ago (con fig. ●)	needle control assembly (with fig. ●)	cinématisme comm. aiguille (avec fig. ●)		
●	208161-4-01	1	slitta con barra completa	slide with bar assembly	glissière avec barre complète		
▲	207515-4-00	1	morsetto porta aghi completo	needles clamp assembly	porte-aiguilles complet		
1	207930-0-00	1	spina	pin	goupille		
2	778414-0-00	1	stoppino	wick	mèche		
3	778204-0-00	3	stoppino	wick	mèche		
4	745812-0-00	5	vite	screw	vis		
5	207692-2-00	2	anello di rasamento con viti	ring with screw	anneau avec vis		
6	207932-0-00	1	leva	lever	levier		
7	778509-0-00	1	stoppino	wick	mèche		
8	729034-2-00	3	vite	screw	vis		
9	208163-4-00	1	perno con stoppini e tappo	pin with wick and plug	pivot avec mèche et bouchon		
10	778417-0-00	1	stoppino	wick	mèche		
11	206521-0-00	1	tappo	plug	bouchon		
12	778511-0-00	2	stoppino	wick	mèche		
13	745421-0-00	1	vite	screw	vis		
14	206533-0-00	1	coperchio per leva	cover for lever	couvercle pour levier		
15	724032-0-00	1	vite	screw	vis		
16	309562-0-00	1	rondella	washer	rondelle		
17	208143-3-01	1	gruppo leva con spina	lever with pin assembly	groupe levier avec goupille		
18	741405-0-00	1	vite	screw	vis		
19	778208-0-00	1	stoppino	wick	mèche		
20	310167-0-00	1	vite	screw	vis		
21	207922-3-10	1	slitta con barra	slide with bar	glissière avec barre		
22	729012-2-00	1	vite	screw	vis		
23	727021-0-00	1	vite	screw	vis		
24	778206-0-00	1	stoppino	wick	mèche		
25	207525-2-00	1	morsetto porta aghi	needles clamp	porte-aiguilles		
26	745810-2-00	2	vite	screw	vis		
27	729051-2-00	1	vite	screw	vis		
28	727014-2-00	1	vite	screw	vis		
29	207927-0-01	1	perno	pin	pivot		
30	778419-0-00	1	stoppino	wick	mèche		
31	778503-0-00	1	stoppino	wick	mèche		
32	745002-0-00	2	vite	screw	vis		
33	206603-0-10	1	vite di fermo	screw	vis		
34	206606-2-00	1	anello di rasamento con vite	ring	anneau		
35	705029-0-00	1	rondella	washer	rondelle		
36	778837-0-00	1	stoppino	wick	mèche		
37	741415-2-00	1	vite	screw	vis		
38	207544-0-00	1	guidafilo	thread guide	guide-fil		
39	765510-6-80	2	ago RIM 29A fin. 80	needle RIM 29A size 80	aiguille RIM 29A jauge 80		
40	744334-2-00	1	vite	screw	vis		
41	206542-2-00	1	manovella alb. sup. con vite	crank	manivelle		

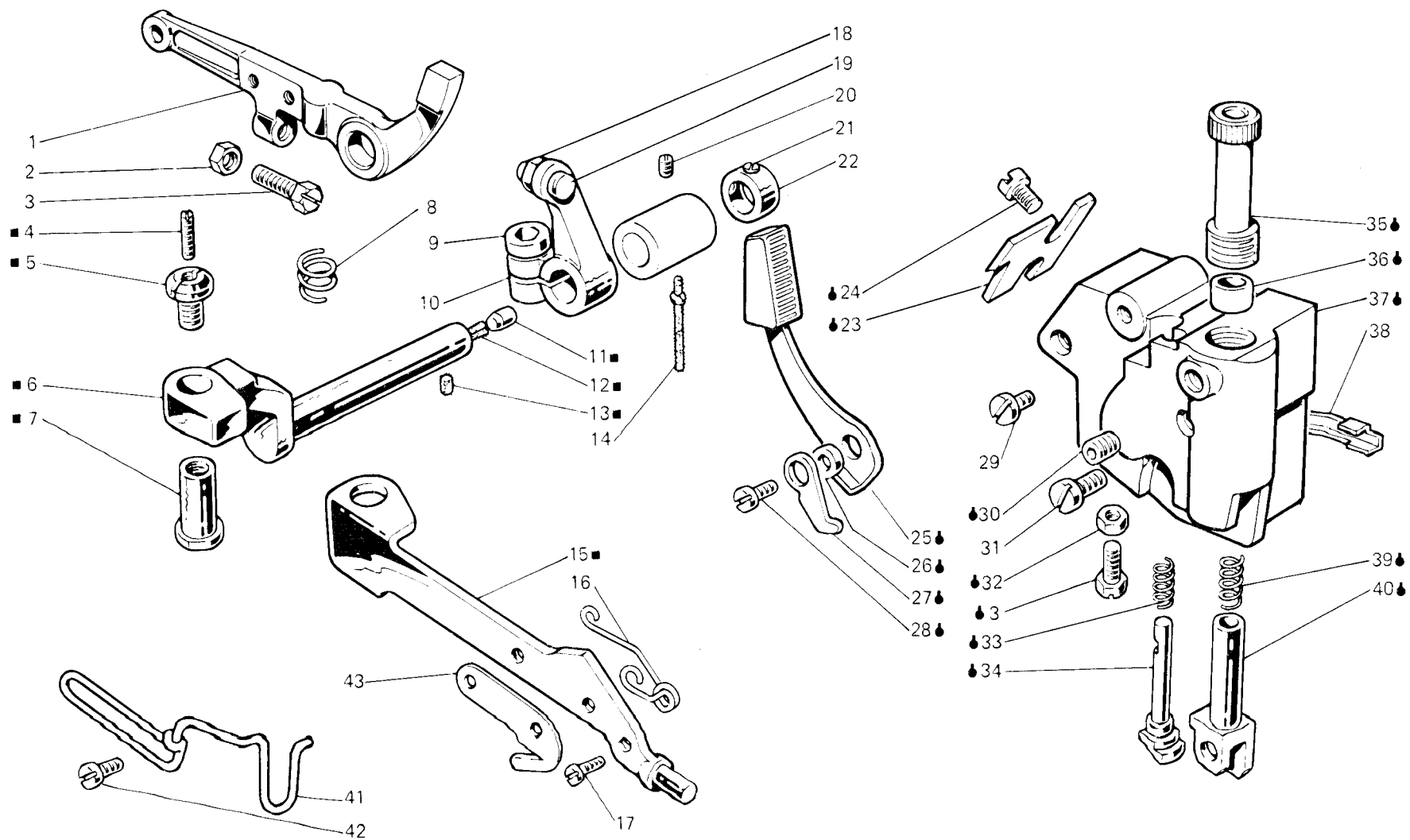

Fig. Abb. N.	Part. Bestell. N. Piece N. Pieza N.	Qt. Anzahl	DESCRIZIONE	DESCRIPTION	DESCRIPTION	BENENNUNG	DESCRIPCION
●	208136-4-00	1	gruppo supporto premistoffa	presser support assembly	groupe support pied-presseur		
■	207886-4-00	1	leva premistoffa con perno	presser lever	levier du pied presseur		
1	207881-2-00	1	leva alza premistoffa	lever	levier		
2	733505-2-00	1	dado	nut	écrou		
3	202214-0-11	2	vite	screw	vis		
4	729051-2-00	1	vite	screw	vis		
5	202529-0-10	1	perno di fermo	pin	pivot		
6	207878-3-00	1	perno con tappo e stoppino	pin with plug and wicks	pivot avec bouchon et mèches		
7	206622-0-00	1	spina	pin	goupille		
8	206621-0-00	1	molla richiamo leva alza premist.	spring	ressort		
9	744332-2-00	1	vite	screw	vis		
10	207876-2-00	1	leva arresto premist. con viti	lever	levier		
11	301586-0-10	1	pastiglia	plug	bouchon		
12	778522-0-00	1	stoppino	wick	mèche		
13	778204-0-00	1	stoppino	wick	mèche		
14	206620-0-00	1	stoppino buss.perno leva premist.	wick	mèche		
15	206625-0-01	1	leva	lever	levier		
16	204891-0-11	1	molla premi piedino	spring	ressort		
17	203187-0-10	1	vite	screw	vis		
18	746020-2-00	1	dado	nut	écrou		
19	727096-0-00	1	vite	screw	vis		
20	745812-2-00	1	vite	screw	vis		
21	745114-0-00	2	vite	screw	vis		
22	207882-2-00	1	anello con viti	ring	anneau		
23	207965-0-00	1	arresto	stopping	butée		
24	721434-2-00	2	vite	screw	vis		
25	208133-2-00	1	leva	lever	levier		
26	206637-0-00	1	distanziale	spacer	entretoise		
27	206635-0-00	1	nasello	snug	décllic		
28	722063-2-00	1	vite	screw	vis		
29	721524-2-00	1	vite	screw	vis		
30	202391-0-11	1	vite	screw	vis		
31	206642-0-00	1	vite	screw	vis		
32	746007-2-00	1	dado	nut	écrou		
33	202110-0-10	1	molla	spring	ressort		
34	207959-0-00	1	tirante	tie-rod	tirant		
35	207967-0-00	1	vite	screw	vis		
36	206882-0-00	1	distanziale	spacer	entretoise		
37	207960-0-00	1	supporto	support	support		
38	207962-0-00	1	guarnizione per supporto	gasket for support	garniture pour support		
39	205021-0-10	1	molla	spring	ressort		
40	206632-2-00	1	cannotto	column	fourche		
41	990693-0-00	1	salvadita	protection	protection		
42	741453-0-00	2	vite	screw	vis		
43	202194-0-10	1	piastrina tagliafilo	plate	plaque		

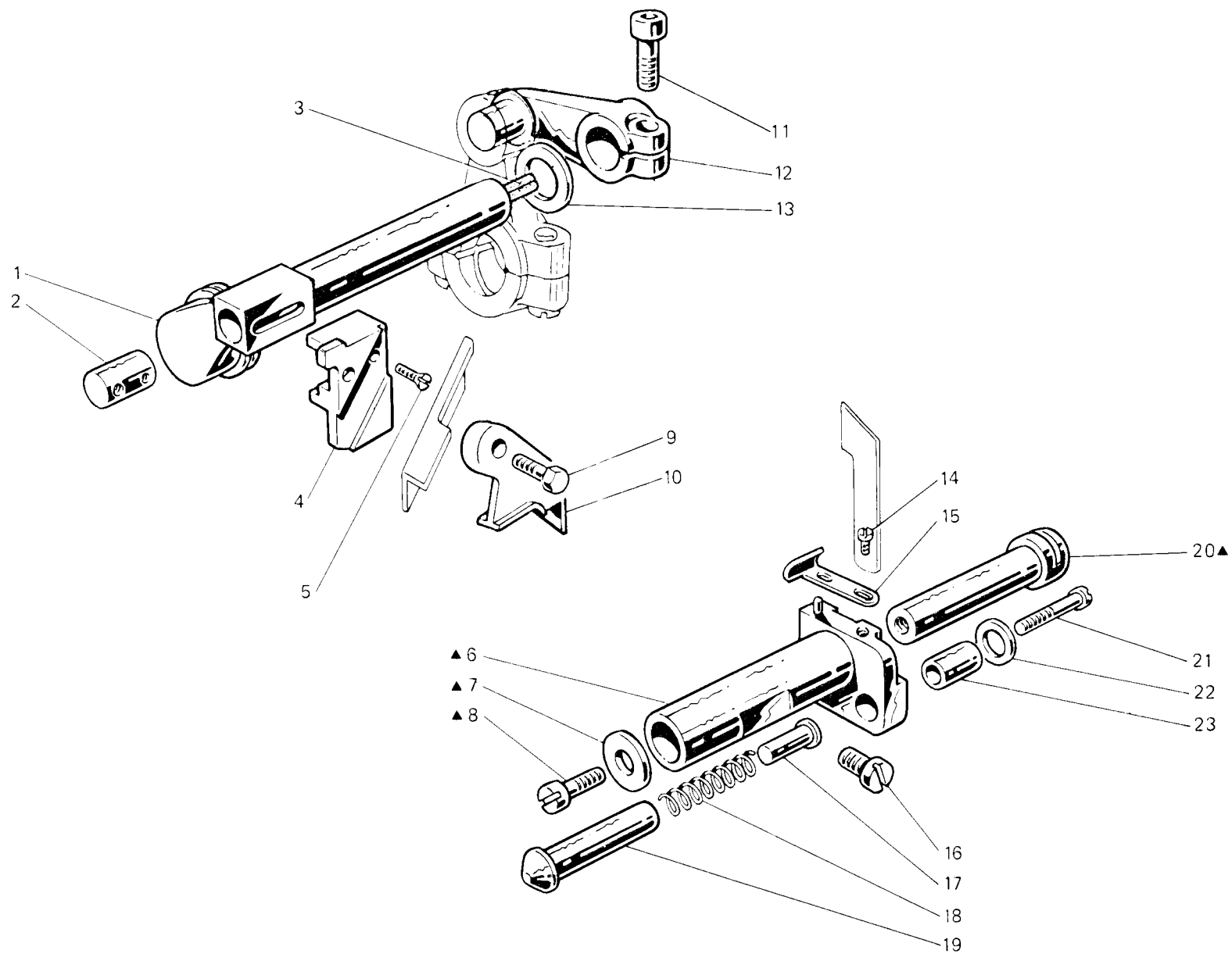

Fig. N. Abb. N.	Part. N. Bestell N. Piece N. Pieza N.	Qt. Anzahl	DESCRIZIONE	DESCRIPTION	DESCRIPTION	BENENNUNG	DESCRIPCION
▲	204860-4-10	1	gruppo porta coltello infer.	lower knife assembly			
1	207861-4-00	1	albero colt.sup. con stoppini	upper knife shaft with wick			
2	202130-0-11	1	perno	pin			
3	778835-0-00	1	stoppino	wick			
4	207650-0-01	1	placchetta	plate			
5	744573-0-00	1	vite	screw			
6	204684-2-11	1	porta coltello inferiore	lower knife holding			
7	704409-0-00	1	rondella	washer			
8	742457-2-00	1	vite fissa coltello inferiore	screw			
9	207417-0-00	1	vite	screw			
10	207653-0-01	1	staffa	bracket			
11	744334-2-00	1	vite	screw			
12	206574-2-00	1	manov.alb.sup.con vite	crank for upper knife shaft			
13	705029-0-00	1	rondella	washer			
14	741520-0-00	1	vite	screw			
15	204690-0-10	1	salva ago	rear needle guard			
16	742758-0-00	1	vite	screw			
17	206758-0-00	1	puntalino	pin			
18	202128-0-10	1	molla	spring			
19	206757-0-00	1	bussolina	bush			
20	204687-0-10	1	perno	pin			
21	722471-2-00	1	vite	screw			
22	704406-0-00	1	rondella	washer			
23	202129-0-10	1	bussola	bush			

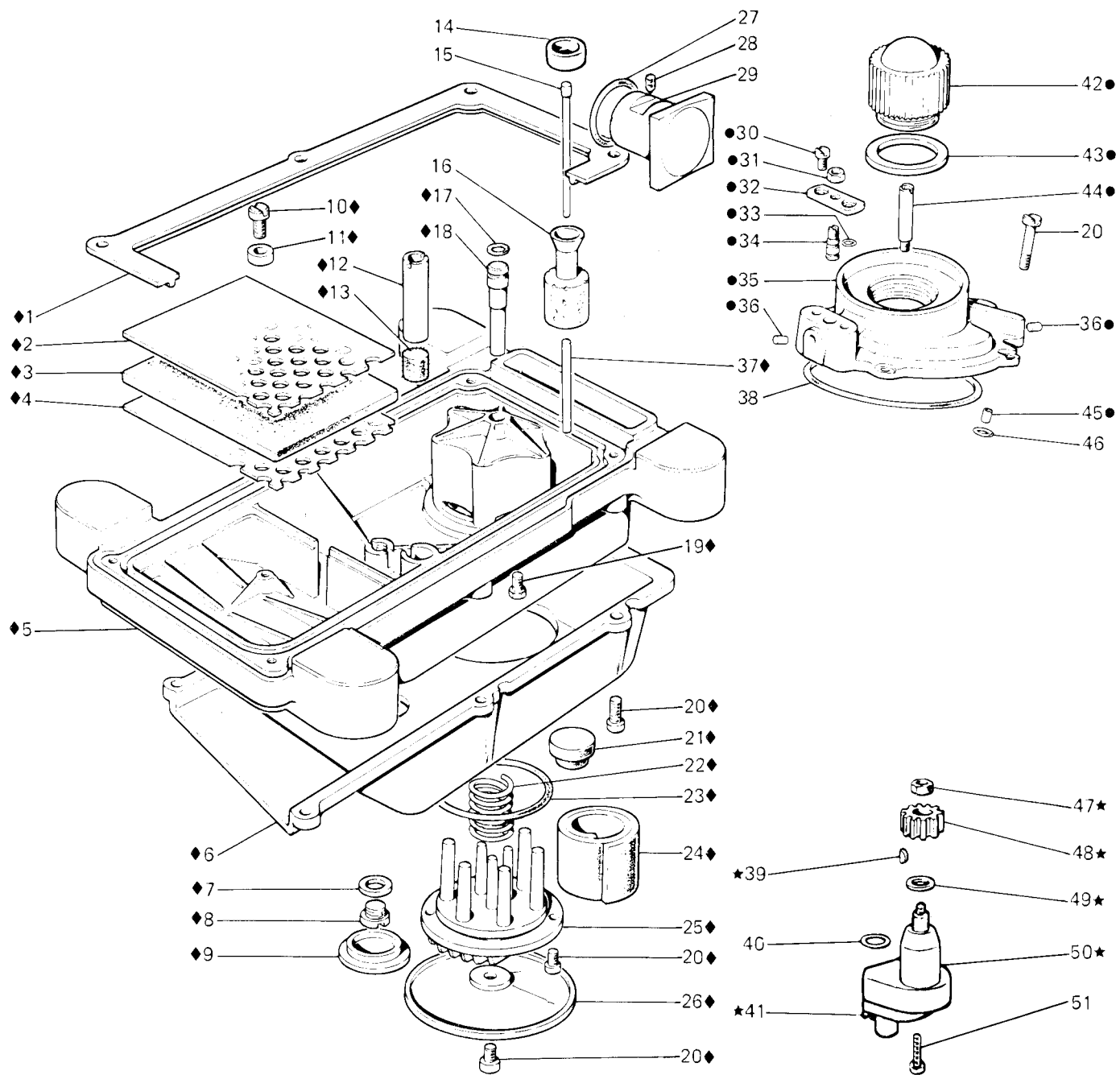



Fig. N. Abb. N.	Part. N. Piece N. Bestell N. Pieza N.	Qt. Anzahl	DESCRIZIONE	DESCRIPTION	DESCRIPTION	BENENNUNG	DESCRIPCION
●	207972-4-00	1	coperchio distrib.olio compl.	cover assembly	couvercle complet		
★	206550-4-03	1	gruppo pompa olio	oil pump assembly	groupe pompe huile		
◆	208012-4-00	1	bacinella olio completa	oil sump assembly	réservoir huile complet		
1	207909-0-00	1	guarnizione bacinella	gasket	garniture		
2	206567-0-01	1	lamiera forata superiore	upper sheet	plaque perforée sup.		
3	206566-0-00	1	filtro	filter	filtre		
4	206565-0-00	1	lamiera forata inferiore	lower sheet	plaque perforée inf.		
5	207901-0-00	1	bacinella	oil sump	réservoir		
6	206750-0-00	1	convogliatore	conveyor	convoyeur		
7	705977-0-00	1	rondella	washer	rondelle		
8	206564-0-00	1	tappo	plug	bouchon		
9	206752-0-00	1	tappo	plug	bouchon		
10	721484-2-00	1	vite	screw	vis		
11	990335-0-10	1	distanziale	spacer	entretoise		
12	206568-0-01	1	tubetto	pipe	tube		
13	206569-0-01	1	filtro	filter	filtre		
14	206667-0-00	1	tappo decompressione	plug	bouchon		
15	207975-0-00	1	astina indicat. liv.olio	stick	jauge niveau huile		
16	206665-2-00	1	galleggiante completo	float assembly	flotteur complet		
17	701005-0-00	1	anello di tenuta	retainer ring	bague d'étanchéité		
18	206558-0-01	1	tubo aspirante	tube	tube		
19	720411-2-00	1	vite	screw	vis		
20	722063-2-00	13	vite	screw	vis		
21	206751-0-00	4	tampone	pad	tampon		
22	206545-0-00	1	spirale per coperchio	spiral for cover	spirale pour couvercle		
23	701051-0-00	1	guarnizione	gasket	garniture		
24	206559-0-01	1	filtro	filter	filtre		
25	206560-0-10	1	coperchio	cover	couvercle		
26	206753-0-00	1	coperchio	cover	couvercle		
27	701124-0-00	1	anello di tenuta	retainer ring	bague d'étanchéité		
28	729022-2-00	1	vite	screw	vis		
29	207974-0-00	1	indicatore livello olio	oil level gauge	indicateur niveau huile		
30	741535-0-00	2	vite	screw	vis		
31	746007-2-00	1	dado	nut	écrou		
32	207979-0-00	1	piastrina	plate	plaque		
33	701002-0-00	1	anello di tenuta	retainer ring	bague d'étanchéité		
34	207978-0-00	1	pistoncino	piston	piston		
35	207970-2-00	1	coperchio con tappo	cover with plug	couvercle with bouchon		
36	301586-0-10	2	tappo	plug	bouchon		
37	206662-0-00	1	spina	pin	goupille		
38	701151-0-00	1	anello di tenuta	retainer ring	bague d'étanchéité		
39	206557-0-00	1	chiavetta	key	clavette		
40	701004-0-00	1	anello di tenuta	retainer ring	bague d'étanchéité		
41	721494-2-00	2	vite	screw	vis		
42	207973-0-00	1	cupolina	cup	coupole		
43	705970-0-00	1	guarnizione	gasket	garniture		
44	207971-0-00	1	ugello	nozzle	gicleur		
45	207977-0-00	1	bussolina	bush	bague		

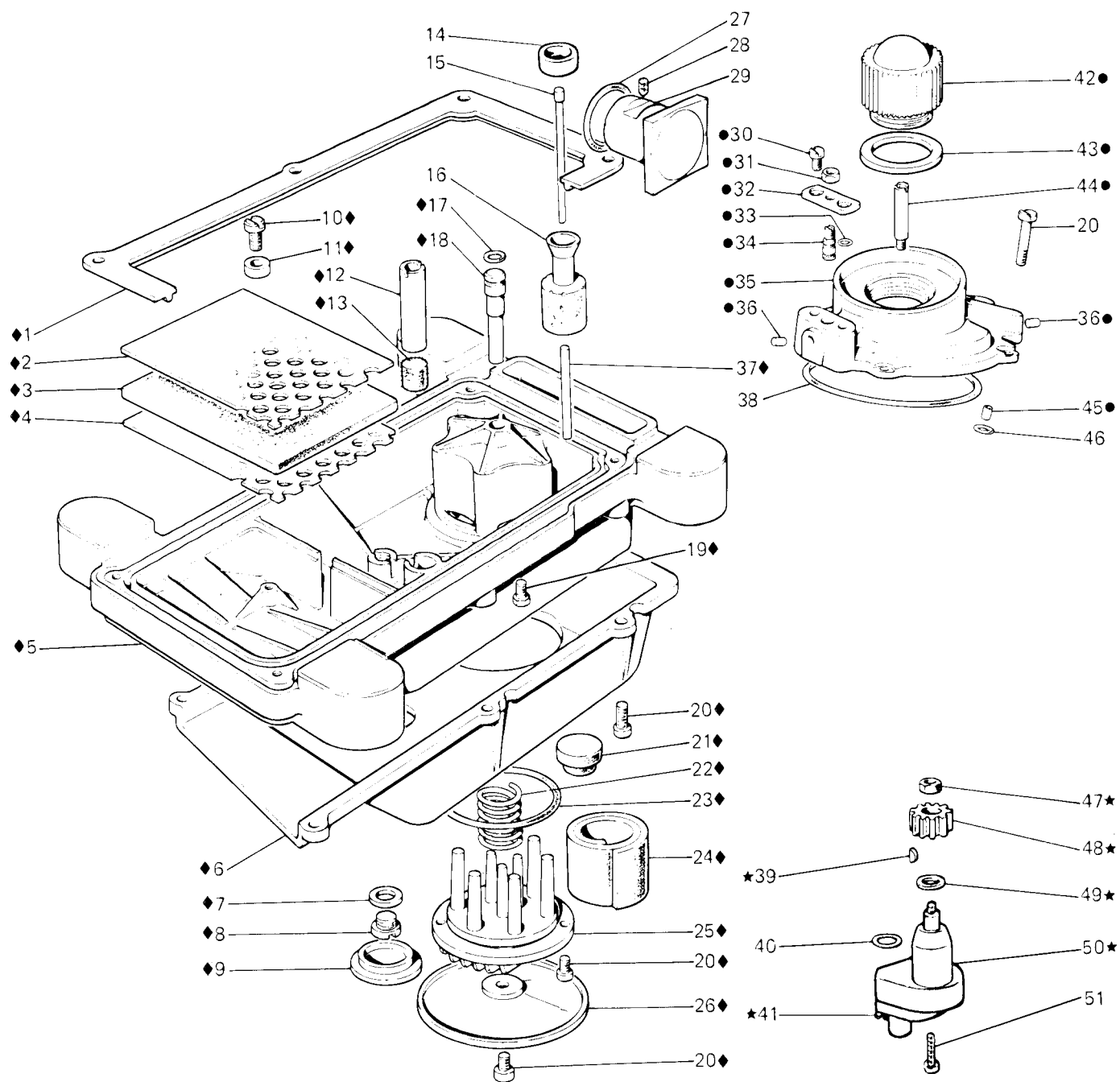

Fig. N. Abb N.	Part. N. Piece N. Bestell N. Preza N.	Qt. Anzahl	DESCRIZIONE	DESCRIPTION	DESCRIPTION	BENENNUNG	DESCRIPCION
46	701106-0-00	1	anello di tenuta	retainer ring		bague d'étanchéité	
47	733507-0-00	1	dado	nut		écrou	
48	206555-0-01	1	ruota	wheel		roue	
49	704813-0-00	1	rondella	washer		rondelle	
50	206554-0-02	1	coperchio	cover		couvercle	
51	722511-2-00	2	vite	screw		vis	

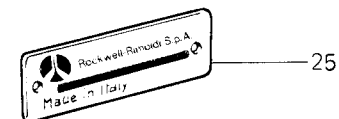
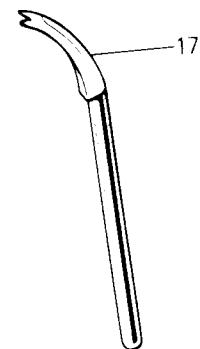
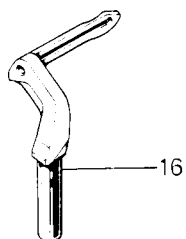
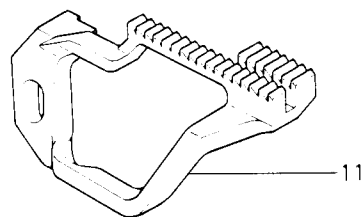
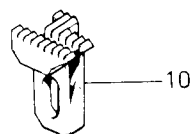
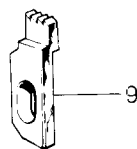
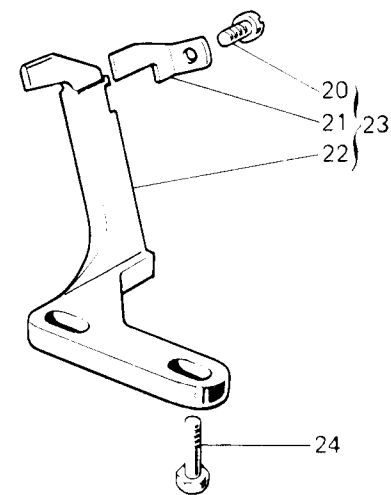
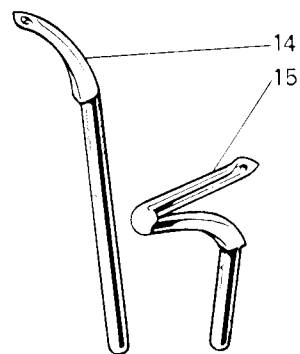
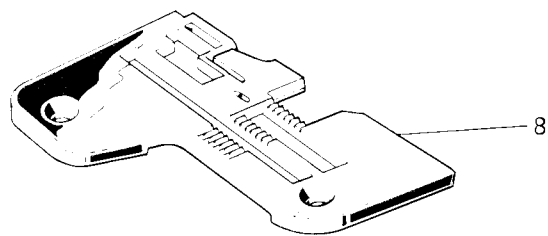
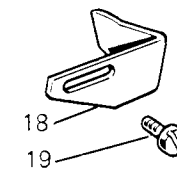
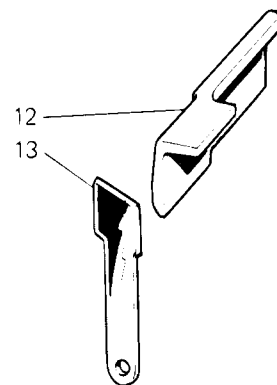
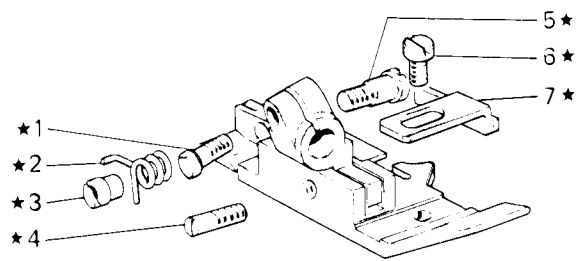

Fig. N. Abb. N.	Part. N. Bestell N. Piece N. Pieza N.	Qt. Anzahl	DESCRIZIONE	DESCRIPTION	DESCRIPTION	BENENNUNG	DESCRIPCION
★	204826-3-11	1	piedino completo	presser foot assembly		pied-presseur complet	
1	204947-0-10	1	vite	screw		vis	
2	204894-0-11	1	molla	spring		ressort	
3	204895-0-11	1	bussola filettata	bush		bague	
4	204869-0-11	1	spina filettata	pin		goupille	
5	204889-0-10	1	vite	screw		vis	
6	741413-2-00	1	vite	screw		vis	
7	204878-0-11	1	piastrina	plate		plaque	
8	204821-0-12	1	placca ago larg. costa 3 mm.	needle plate width bight 3 mm.		plaque à aiguille largeur surjet 3 mm.	
9	204819-0-10	1	griffino	feed dog		petite griffe	
10	204816-0-10	1	griffa sussidiaria	subsidiary feed dog		griffe subsidiaire	
11	204813-0-11	1	griffa principale	main feed dog		griffe principale	
12	203783-0-10	2	coltello superiore	upper knife		couteau supérieur	
13	204693-0-11	2	coltello inferiore	lower knife		couteau inférieur	
14	204033-0-10	1	crochet superiore	upper looper		crochet supérieur	
15	202413-0-11	1	crochet inferiore	lower looper		crochet inférieur	
16	207722-0-01	1	crochet punto sicurezza	safety stitch looper		crochet point de sûreté	
17	202092-0-11	1	crochet superiore cieco	upper blind looper		crochet supérieur aveugle	
18	204905-0-10	1	squadretta	bracket		équerre	
19	721443-2-00	1	vite	screw		vis	
20	741431-0-00	1	vite	screw		vis	
21	204863-0-11	1	salva ago	rear needle guard		protège-aiguille	
22	204861-0-10	1	spingi asola	front needle guard		pare-boucle	
23	204862-4-11	1	gruppo spingi asola e salva ago	front and rear needle guard ass.		groupe pare-boucle et protège-aiguille	
24	740230-2-00	2	vite	screw		vis	
25	780200-0-40	1	targhetta classe testa	head class plate		plaque classe tête	
			SOLO A RICHIESTA	ONLY ON REQUEST		SEULEMENT SUR DEMANDE	
8	204837-0-00	1	placca ago larg. costa 3,2 mm.	needle plate width bight 3,2 mm		plaque à aiguille largeur surjet 3,2 mm.	
	204838-0-01	1	placca ago larg. costa 5 mm.	needle plate width bight 5 mm.		plaque à aiguille largeur surjet 5 mm.	
10	205538-0-00	1	griffa sussidiaria	subsidiary feed dog		griffe subsidiaire	
11	205539-0-01	1	griffa principale	main feed dog		griffe principale	
12	203759-0-10	1	coltello superiore	upper knife		couteau supérieur	
	207003-2-00	1	coltello superiore	upper knife		couteau supérieur	
	207004-2-00	1	coltello superiore	upper knife		couteau supérieur	
13	207020-2-01	1	coltello inferiore	lower knife		couteau inférieur	

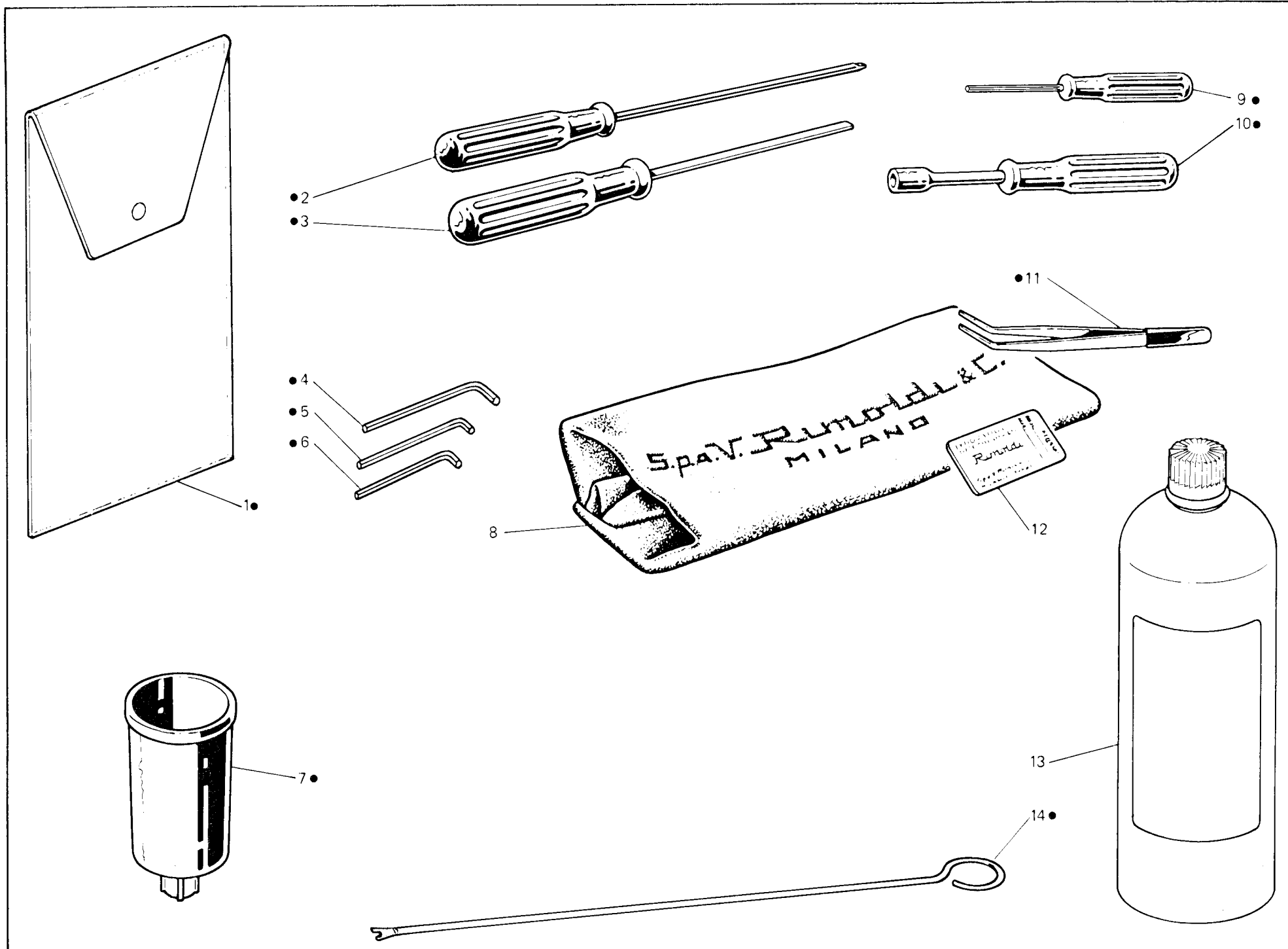
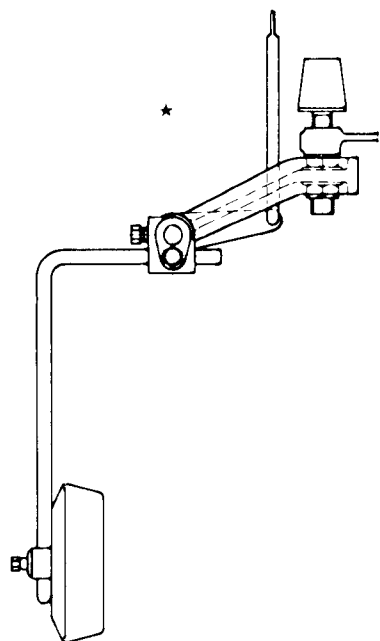

Fig. N. Abb. N.	Part. N. Piece N. Bestell N. Pieza N.	Qt. Anzahl	DESCRIZIONE	DESCRIPTION	DESCRIPTION	BENENNUNG	DESCRIPCION
●	991401-4-00	1	busta accessori completa	accessories envelope assembly	envelope accessoires complète		
1	991415-0-00	1	busta accessori	accessories envelope	envelope accessoires		
2	990180-0-10	1	cacciavite grande	screw driver	gros tournevis		
3	990181-0-10	1	cacciavite medio	screw driver	tournevis moyen		
4	990639-0-10	1	chiave esagonale da 3 mm.	3 mm hexagonal key	clé hexagonale de 3 mm		
5	990685-0-10	1	chiave esagonale da 2,5 mm.	2,5 mm hexagonal key	clé hexagonale de 2,5 mm.		
6	990325-0-10	1	chiave esagonale da 2 mm.	2 mm hexagonal key	clé hexagonale de 2 mm		
7	990985-0-00	1	imbuto	oil funnel	entenoir		
8	990183-0-12	1	cuffia protezione testa	machine cover	couverture protection tête		
9	990474-0-11	1	chiave esagonale da 1,5 mm	1,5 mm hexagonal key	clé hexagonale de 1,5 mm		
10	990324-0-10	1	chiave a tubo da 7 mm	7 mm key	clé de 7 mm		
11	990176-0-10	1	pinza per infilatura	threading clers	pince pour enfilage		
12	★	1	bustina aghi	needles packet	paquette aiguilles		
13	990075-1-13	1	lattina olio da 1 Kg.	oil container (1 Kg)	bidon hile de 1 Kg		
14	990577-0-10	1	astina per infilatura	threading rod	tige pour enfilage		
			★per l'ordinazione della bustina citare lo stesso simbolo dell'ago montato sulla testa	★to order packet of needles pleasi specify symbol of needle fitted on machine	★pour commander un sachet d'aiguille donner le symbol de l'aiguille montée sur la tête		

PIAZZAMENTO NORMALE  
NORMAL SETTING



PIAZZAMENTO INCASSATO  
SUBMERGED SETTING

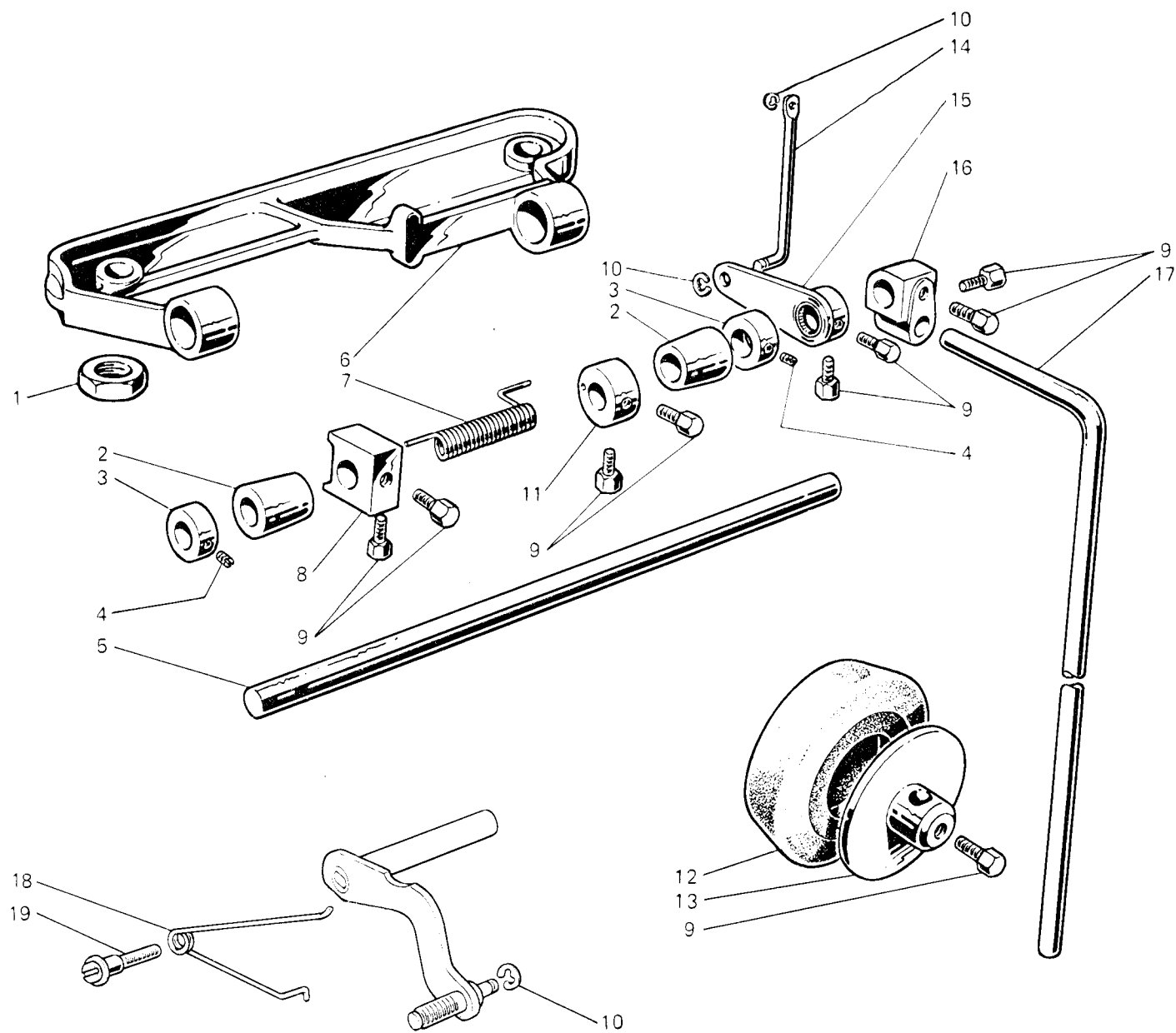
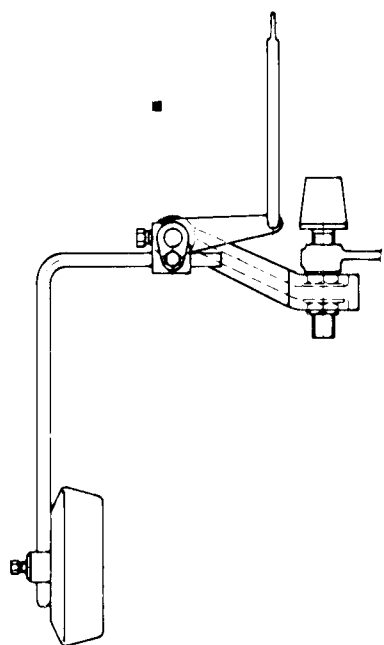



Fig. N. Abb. N.	Part. N. Bestell N. Piece N. Pieza N.	Qt. Anzahl	DESCRIZIONE	DESCRIPTION	DESCRIPTION	BENENNUNG	DESCRIPCION
★	920245-4-01	1	ginocchietto completo (piazzamento normale)	knee-press assembly (normal setting)	genouillère complète (installation normal)		
■	920246-4-01	1	ginocchietto completo (piazzamento incassato)	knee-press assembly (submerged setting)	genouillère complète (installation encastrée)		
1	733008-2-00	2	dado	nut	écrou		
2	920231-0-00	2	bussola	bush	bague		
3	920242-2-00	2	anello	ring	anneau		
4	729013-2-00	2	vite	screw	vis		
5	920230-0-00	1	albero	shaft	arbre		
6	920241-0-00	1	supporto	support	support		
7	920235-0-00	1	molla (piazz. normale)	spring (normal setting)	ressort (installation normal)		
	920106-0-10	1	molla (piazz. incassato)	spring (submerged setting)	ressort (installation encastrée)		
8	920128-0-00	1	ancora	anchoring	butée		
9	740035-0-00	9	vite	screw	vis		
10	700206-0-00	2	anello elastico	spring ring	anneau ressort		
11	920114-0-10	1	anello	ring	anneau		
12	920113-0-10	1	cuscinio	pad	coussin		
13	920105-0-10	1	disco	disc	disque		
14	920236-0-01	1	tirante (piazz. normale)	tie-rod (normal setting)	tirante (installation normal)		
	920237-0-01	1	tirante (piazz. incassato)	tie-rod (submerged setting)	tirante (installation encastrée)		
15	920232-2-00	1	leva	lever	levier		
16	920103-0-10	1	attacco	coupling	raccord		
17	920490-0-10	1	asta	rod	tige		
			SOLO A RICHIESTA	ONLY ON REQUEST	SEULEMENT SUR DEMANDE		
18	920896-0-00	1	molla	spring	ressort		
19	920897-0-00	1	vite	screw	vis		

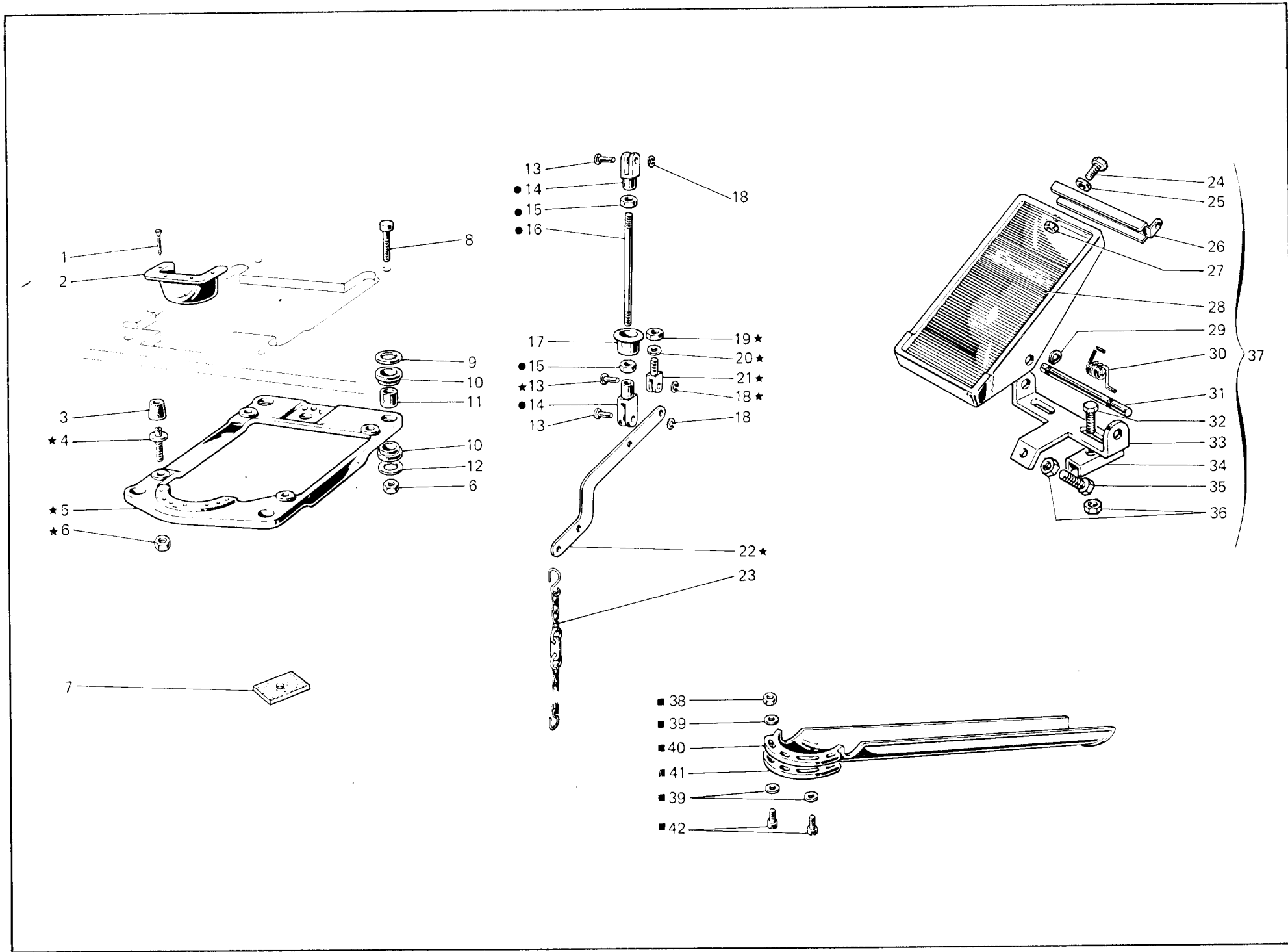

Fig. N. Abb. N.	Part. N. Bestell N. Piece N. Pieza N.	Qt. Anzahl	DESCRIZIONE	DESCRIPTION	DESCRIPTION	BENENNUNG	DESCRIPCION
★	990986-4-00	1	PIAZZAMENTO NORMALE	NORMAL SETTING	INSTALLATION NORMAL		
●	990984-4-00	1	supporto testa completo	head support assembly	support tête complet		
1	900201-0-10	4	tirante alza piedino completo	presser tie rod assembly	tirant pour soulèvement pied-presseur		
2	991187-0-00	1	chiodino	rivet	clou		
3	990982-0-00	4	bocchetta	cup	bouche		
4	900694-0-11	4	ammortizzatore	shock absorber	amortisseur		
5	990981-0-00	1	perno	pin	pivot		
6	733008-2-00	8	supporto testa	head support	support tête		
7	900203-0-10	4	dado	nut	écrou		
8	722905-2-00	4	ammortizzatori per tavola	shock absorber	amortisseur		
9	704346-2-00	4	vite	screw	vis		
10	901101-0-00	8	rondella	washer	rondelle		
11	901102-0-00	4	ammortizzatore	shock absorber	amortisseur		
12	704345-2-00	4	distanziale	spacer	entretoise		
13	990311-0-10	3	rondella	washer	rondelle		
14	990310-0-10	2	perno	pin	pivot		
15	746402-2-00	2	giunto	joint	joint		
16	990983-0-00	1	dado	nut	écrou		
17	900204-0-10	1	tirante	tie-rod	tirant		
18	700205-0-00	3	bussola	bush	bague		
19	746409-2-00	1	anello elastico	spring ring	anneau ressort		
20	704424-2-00	1	dado	nut	écrou		
21	990314-0-10	1	rondella	washer	rondelle		
22	990316-0-10	1	supportino	support	support		
23	990179-4-11	1	leva	lever	levier		
24	720464-4-00	2	catenella completa	chain assembly	chaînette complète		
25	704009-4-00	2	vite	screw	vis		
26	900926-0-00	1	rondella	washer	rondelle		
27	733508-4-00	2	attacco	coupling	raccord		
28	900931-0-00	1	dado	nut	écrou		
29	900918-0-00	2	copertura	covering	couverture		
30	900927-0-00	1	anello elastico	spring ring	anneau ressort		
31	900928-0-00	1	molla	spring	anneau		
32	720505-4-00	2	perno	pin	pivot		
33	900929-0-01	1	vite	screw	vis		
34	900920-0-00	2	supporto	support	support		
35	720545-4-00	1	piastrina	plate	plaque		
36	733510-4-00	3	vite	screw	vis		
37	900925-4-01	1	dado	nut	écrou		
			pedalina completa	pedal assembly	pédale complète		
■	991186-1-00	1	SOLO A RICHIESTA	ONLY ON REQUEST	SEULEMENT SUR DEMANDE		
38	733507-2-00	1	gruppo canale scarico ritagli	offlet assembly	groupe décharge chutes		
39	704409-2-00	4	dado	nut	écrou		
40	991186-0-00	1	rondella	washer	rondelle		
41	991189-0-00	1	canale scarico ritagli	offlet	décharge chutes		
42	742068-2-00	3	piastra di rinforzo	plate	plaque		
			vite	screw	vis		

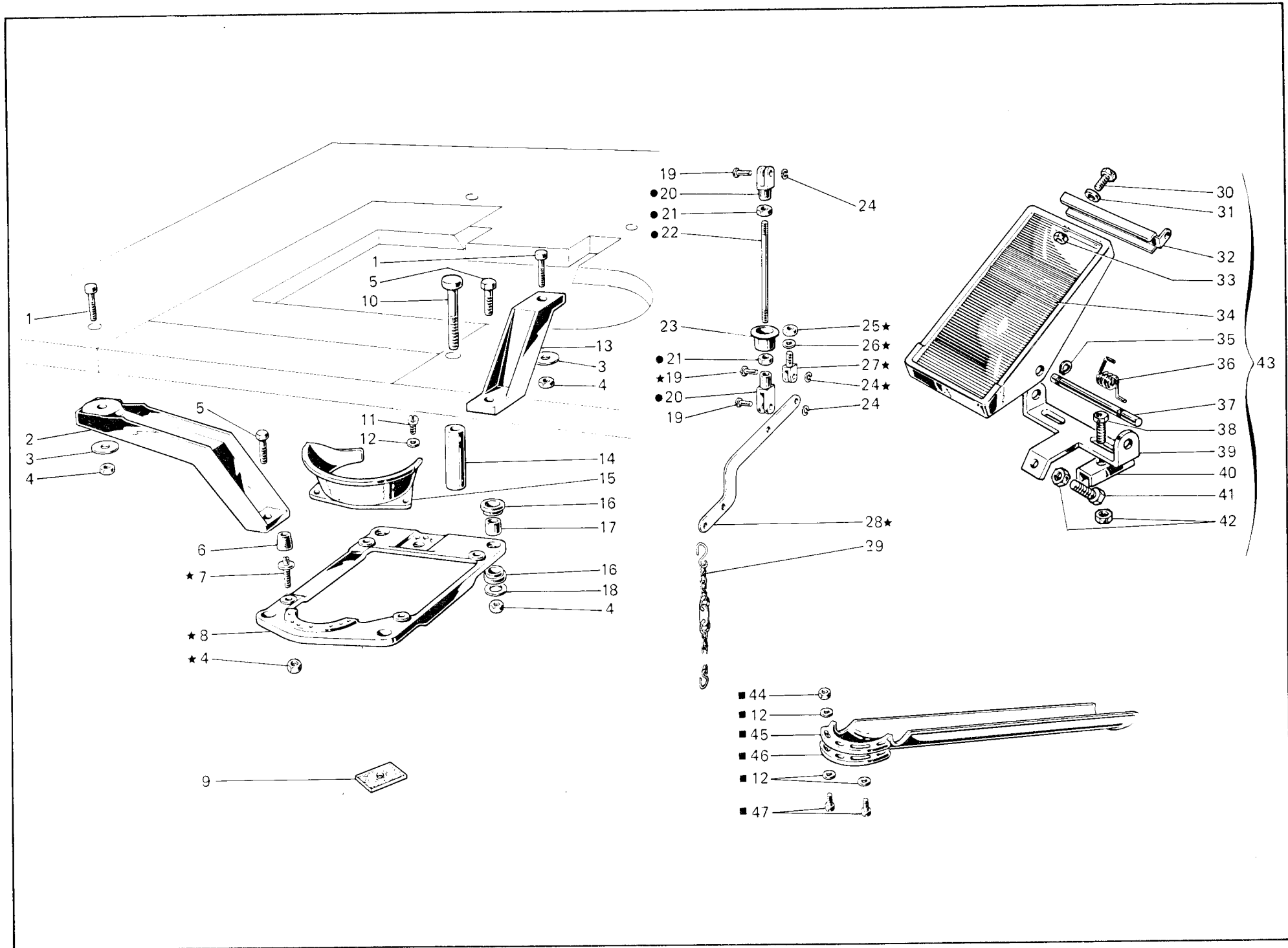

Fig. N. Abb. N.	Part. N. Bestell. N. Pieza N.	Qt. Anzahl	DESCRIZIONE	DESCRIPTION	DESCRIPTION	BENENNUNG	DESCRIPCION
★	990986-4-00	1	PIAZZAMENTO INCASSATO supporto testa completo	SUBMERGED SETTING head support assembly	INSTALLATION ENCASTREE support tête complet		
●	990984-4-00	1	tirante alza piedino completo	presser tie-rod assembly	tirant pour soulèvement pied presseur		
1	722905-2-00	2	vite	screw	vis		
2	901105-0-00	1	staffa laterale	bracket	bride		
3	704536-0-00	2	rondella	washer	rondelle		
4	733008-2-00	6	dado	nut	écrou		
5	720566-2-00	2	vite	screw	vis		
6	990982-0-00	4	ammortizzatore	shock absorber	amortisseur		
7	900694-0-11	4	perno	pin	pivot		
8	990981-0-00	1	supporto testa	head support	support tête		
9	900203-0-10	4	ammortizzatore per tavola	shock absorber	amortisseur		
10	722917-2-00	2	vite	screw	vis		
11	721475-2-00	2	vite	screw	vis		
12	704409-2-00	2	rondella	washer	rondelle		
13	901104-0-00	1	staffa posteriore	bracket	bride		
14	901103-0-10	2	distanziale	spacer	entretoise		
15	991188-0-00	1	bocchetta	cup	bouche		
16	901101-0-00	8	ammortizzatore	shock absorber	amortisseur		
17	901102-0-00	4	distanziale	spacer	entretoise		
18	704345-2-00	4	rondella	washer	rondelle		
19	990311-0-10	3	perno	pin	pivot		
20	990310-0-10	2	giunto	joint	joint		
21	746402-2-00	2	dado	nut	écrou		
22	990983-0-00	1	tirante	tie-rod	tirante		
23	900204-0-10	1	bussola	bush	bague		
24	700205-0-00	3	anello elastico	spring ring	anneau ressort		
25	746409-2-00	1	dado	nut	écrou		
26	704424-2-00	1	rondella	washer	rondelle		
27	990314-0-10	1	supportino	support	support		
28	990316-0-10	1	leva	lever	levier		
29	990179-4-11	1	catenella completa	chain assembly	chaînette complète		
30	720464-4-00	2	vite	screw	vis		
31	704009-4-00	2	rondella	washer	rondelle		
32	900926-0-00	1	attacco	coupling	raccord		
33	733508-4-00	2	dado	nut	écrou		
34	900931-0-00	1	copertura	covering	couverture		
35	900918-0-00	2	anello elst.	spring ring	anneau élast.		
36	900927-0-00	1	molla	spring	ressort		
37	900928-0-00	1	perno	pin	pivot		
38	720505-4-00	2	vite	screw	vis		
39	900929-0-01	1	supporto	support	support		
40	900920-0-00	2	piatrina	plate	plaque		
41	720545-4-00	1	vite	screw	vis		
42	733510-4-00	3	dado	nut	écrou		
43	900925-4-01	1	pedalina completa	pedal assembly	pédale complète		
■	991186-1-00	1	SOLO A RICHIESTA gruppo canale scarico ritagli	ONLY ON REQUEST offlet assembly	SEULEMENT SUR DEMANDE groupe décharge chutes		

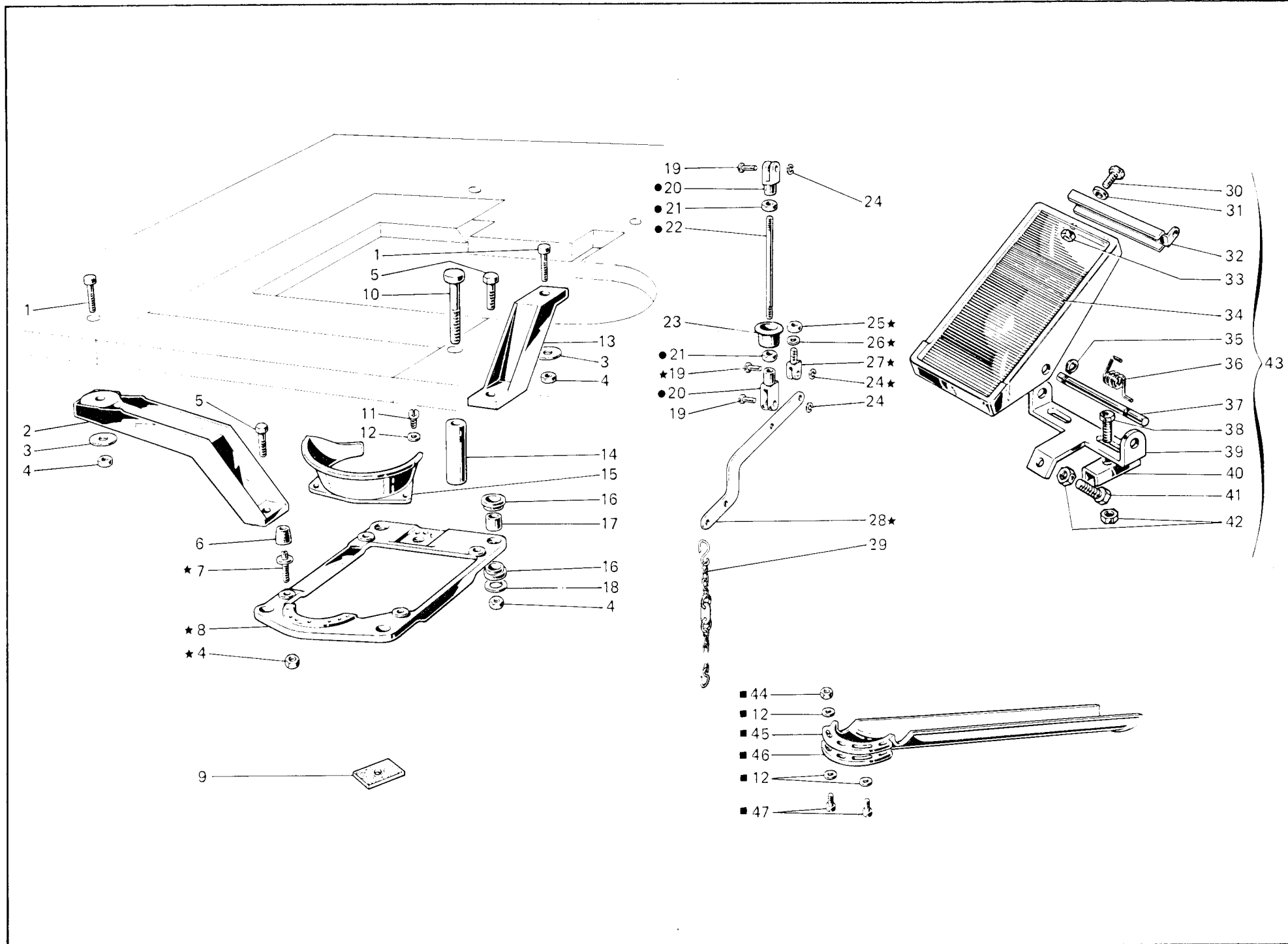

Fig. N. Abb. N.	Part. N. Bestell N. Piece N. Pieza N.	Qt. Anzahl	DESCRIZIONE	DESCRIPTION	DESCRIPTION	BENENNUNG	DESCRIPCION
12	704409-2-00	4	rondella	washer			
44	733507-2-00	1	dado	nut	rondelle		
45	991186-0-00	1	canale scarico ritagli	offlet	écrou		
46	991189-0-00	1	piastra di rinforzo	plate	décharge chutes		
47	742068-2-00	3	vite	screw	plaque		
					vis		

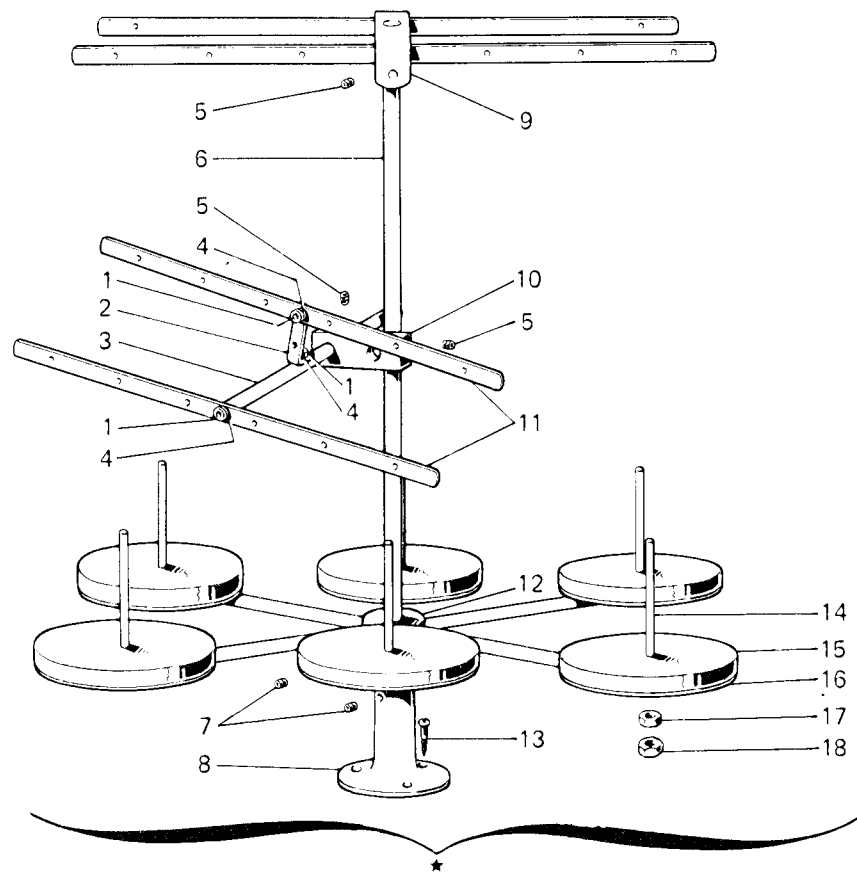



Fig. N. Abb. N.	Part. N. Piese N. Bestell N. Pieza N.	Qt. Anzahl	DESCRIZIONE	DESCRIPTION	DESCRIPTION	BENENNUNG	DESCRIPCION
★	991135-5-00	1	porta bobine compl. (5-6 fili)	bobbin carrier ass. (5-6 threads)	porte bobine compl. (5-6 fils)		
1	722431-2-00	3	vite	screw	vis		
2	991107-2-00	1	squadretta	bracket	équerre		
3	991106-2-00	1	asta	rod	tige		
4	703005-0-00	3	rondella	washer	rondelle		
5	729034-2-00	3	vite	screw	vis		
6	991113-0-00	1	asta principale	main rod	tige principale		
7	729054-2-00	3	vite	screw	vis		
8	991114-2-00	1	basetta con vite	base with screw	base avec vis		
9	991139-3-00	1	telaio sup.completo	upper frame assembly	bâti supérieur complet		
10	991128-2-00	1	blocchetto	block	bloc		
11	991137-2-00	2	telaio con bussole	frame with bush	bâti avec bague		
12	991144-3-00	1	mozzo con aste	hub with rods	moyeu avec tiges		
13	731107-2-00	3	vite da legno	screw	vis		
14	991111-2-00	6	astina	rod	tige		
15	991179-0-00	6	disco	disc	disque		
16	991112-0-00	6	piatto	disc	plateau		
17	733508-2-00	6	dado	nut	écrou		
18	925433-0-00	6	dado	nut	écrou		

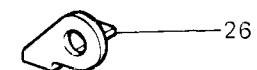
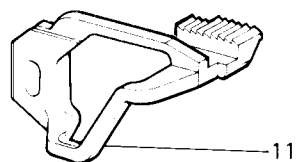
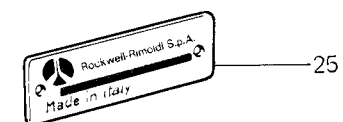
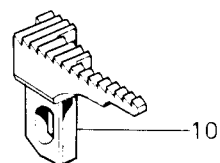
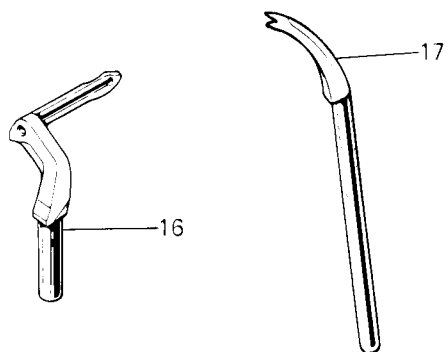
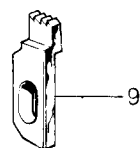
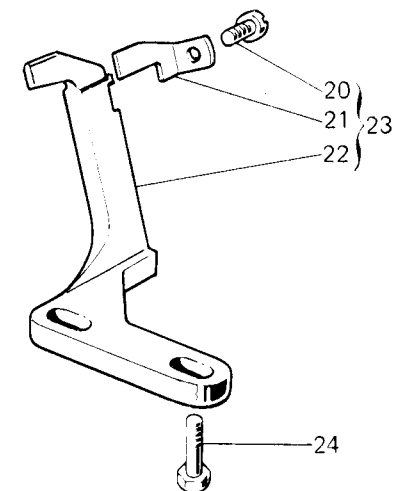
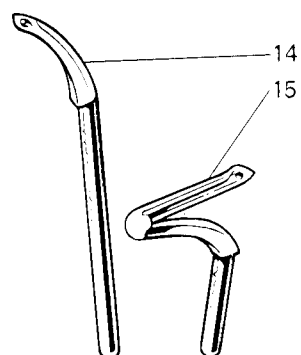
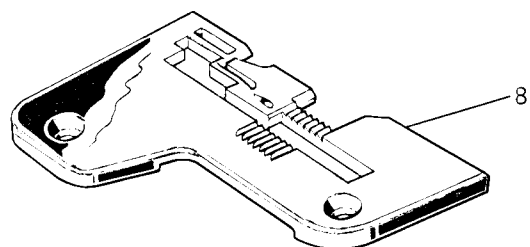
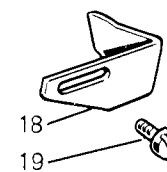
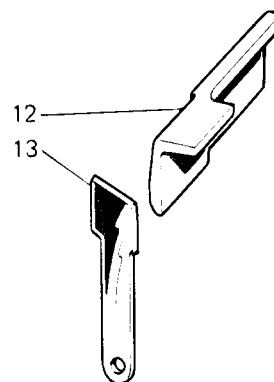
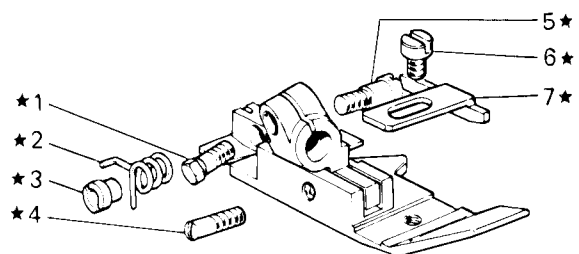

Fig. N. Abb. N.	Part. N. Bestell N. Pezce N. Pieza N.	Qt. Anzahl	DESCRIZIONE	DESCRIPTION	DESCRIPTION	BENENNUNG	DESCRIPCION
★	204827-3-11	1	piedino completo	presserfoot assembly	pied-presseur complet		
1	204947-0-10	1	vite	screw	vis		
2	204894-0-11	1	molla	spring	ressort		
3	204895-0-11	1	bussola filettata	bush	bague		
4	204869-0-11	1	spina filettata	pin	goupille		
5	204889-0-10	1	vite	screw	vis		
6	741413-2-00	1	vite	screw	vis		
7	204878-0-11	1	piastrina	plate	plaque		
8	208075-0-00	1	placca ago larg. costa 3 mm	needle plate width bight 3 mm	plaque à aiguille largeur surjet 3 mm		
9	204819-0-10	1	griffino	feed dog	petite griffe		
10	204817-0-10	1	griffa sussidiaria	subsidiary feed dog	griffe subsidiaire		
11	208076-0-00	1	griffa principale	main feed dog	griffe principale		
12	203783-0-10	2	coltello superiore	upper knife	couteau supérieur		
13	204693-0-11	2	coltello inferiore	lower knife	couteau inférieur		
14	204033-0-10	1	crochet superiore	upper looper	crochet supérieur		
15	202413-0-11	1	crochet inferiore	lower looper	crochet inférieur		
16	207722-0-01	1	crochet punto sicurezza	safety stitch looper	crochet point de sûreté		
17	202092-0-11	1	crochet superiore cieco	upper blind looper	crochet supérieur aveugle		
18	204905-0-10	1	squadretta	bracket	équerre		
19	721443-2-00	1	vite	screw	vis		
20	741431-0-00	1	vite	screw	vis		
21	204863-0-11	1	salva ago	rear needle guard	protège-aiguille		
22	204861-0-10	1	spingi asola	front needle guard	pare-boucle		
23	204862-4-11	1	gruppo spingi asola e salva ago	front and rear needle guard ass.	groupe pare-boucle et protège-aiguille		
24	740230-2-00	2	vite	screw	vis		
25	780200-0-40	1	targhetta classe testa	head class plate	plaque classe tête		
26	204836-0-10	1	squadretta di fermo	bracket	équerre		
			SOLO A RICHIESTA	ONLY ON REQUEST	SEULEMENT SUR DEMANDE		
8	208077-0-00	1	placca ago larg. costa 3,6 mm	needle plate width bight 3,6 mm	plaque à aiguille largeur surjet 3,6 mm		
12	203759-0-10	1	coltello superiore	upper knife	couteau supérieur		
	207003-2-00	1	coltello superiore	upper knife	couteau supérieur		
	207004-2-00	1	coltello superiore	upper knife	couteau supérieur		
13	207020-2-01	1	coltello inferiore	lower knife	couteau inférieur		
16	<u>Tav. 10</u> 204891-0-11	1	PEZZI ANNULLATI molla premi piedino	CANCELLED PARTS spring	PIECES ANNULEES ressort		

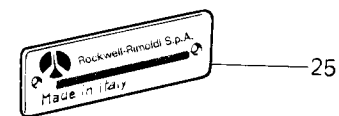
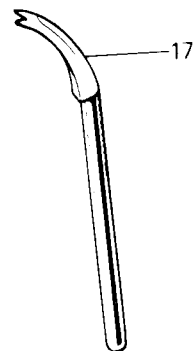
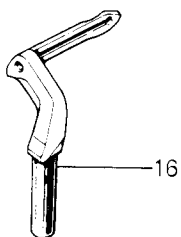
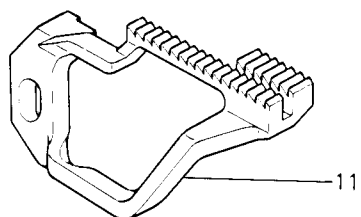
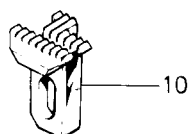
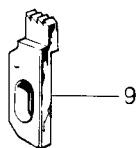
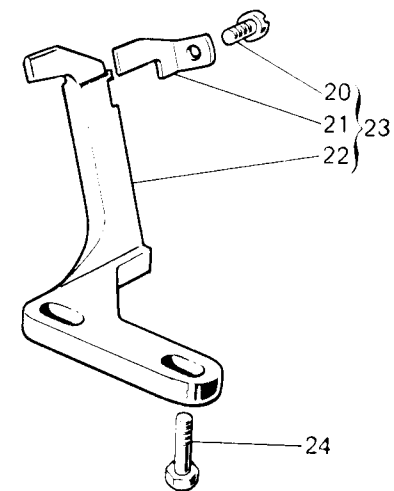
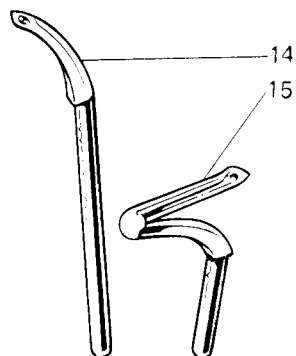
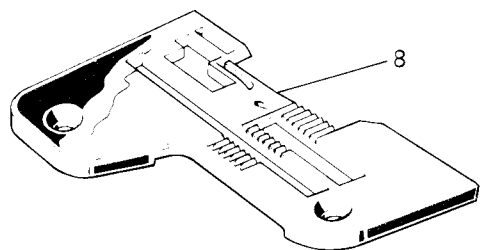
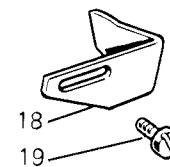
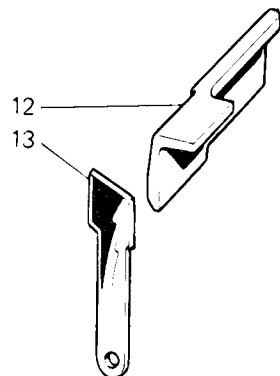
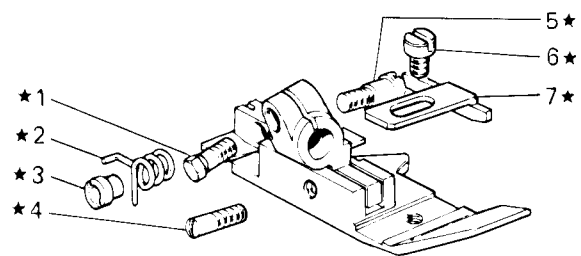

Fig. N. Abb. N.	Part. N. Bestell N. Piece N. Pieza N.	Qt. Anzahl	DESCRIZIONE	DESCRIPTION	DESCRIPTION	BENENNUNG	DESCRIPCION
★	205084-3-11	1	piedino completo	presserfoot assembly	pied-presseur complet		
1	204947-0-10	1	vite	screw	vis		
2	204894-0-11	1	molla	spring	ressort		
3	204895-0-11	1	bussola filettata	bush	bage		
4	204869-0-11	1	spina filettata	pin	goupille		
5	204889-0-10	1	vite	screw	vis		
6	741413-2-00	1	vite	screw	vis		
7	204878-0-11	1	piastrina	plate	plaque		
8	205082-0-10	1	placca ago larg. costa 2,5 mm	needle plate width bight 2,5 mm	plaque à aiguille largeur surjet 2,5 mm		
9	204819-0-10	1	griffino	feed dog	petite griffe		
10	204816-0-10	1	griffa sussidiaria	subsidiary feed dog	griffe subsidiaire		
11	204813-0-11	1	griffa principale	main feed dog	griffe principale		
12	207003-2-00	1	coltello superiore	upper knife	couteau supérieur		
13	207020-2-01	1	coltello inferiore	lower knife	couteau inférieur		
14	204033-0-10	1	crochet superiore	upper looper	crochet supérieur		
15	202413-0-11	1	crochet inferiore	lower looper	crochet inférieur		
16	207722-0-01	1	crochet punto sicurezza	safety stitch looper	crochet point de sûreté		
17	202092-0-11	1	crochet superiore cieco	upper blind looper	crochet supérieur aveugle		
18	204905-0-10	1	squadretta	bracket	équerre		
19	721443-2-00	1	vite	screw	vis		
20	741431-0-00	1	vite	screw	vis		
21	204863-0-11	1	salva ago	rear needle guard	protège-aiguille		
22	204861-0-10	1	spingi asola	front needle guard	pare-boucle		
23	204862-4-11	1	gruppo spingi asola e salva ago	front and rear needle guard ass.	groupe pare-boucle et protège-aiguille		
24	740230-2-00	2	vite	screw	vis		
25	780200-0-40	1	targhetta classe testa	head class plate	plaque classe tête		
			SOLO A RICHIESTA	ONLY ON REQUEST	SEULEMENT SUR DEMANDE		
10	205538-0-00	1	griffa sussidiaria	subsidiary feed dog	griffe subsidiaire		
11	205539-0-01	1	griffa principale	main feed dog	griffe principale		
12	203759-0-10	1	coltello superiore	upper knife	couteau supérieur		
	203783-0-10	1	coltello superiore	upper knife	couteau supérieur		
	207004-2-00	1	coltello superiore	upper knife	couteau supérieur		
13	204693-0-11	1	coltello inferiore	lower knife	couteau inférieur		
15	<u>Tav. 11</u> 205080-0-10	1	spingi asola	front needle guard	pare-boucle		

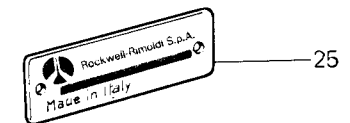
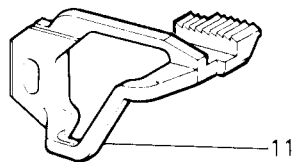
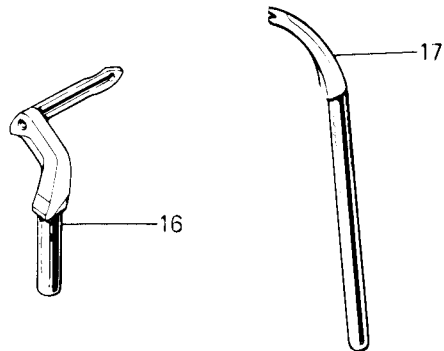
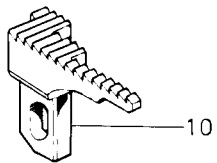
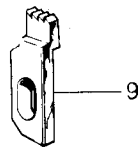
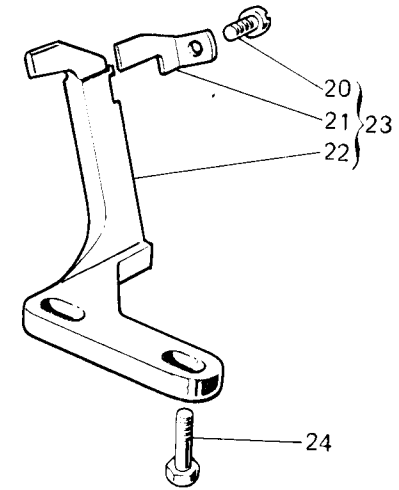
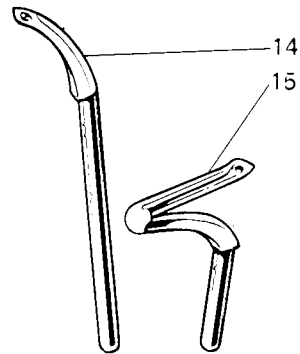
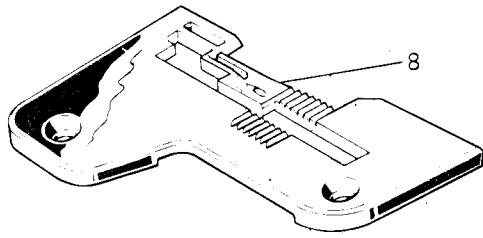
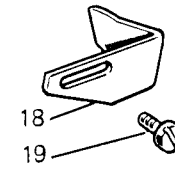
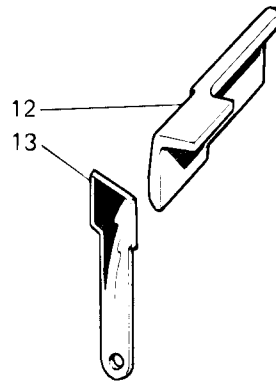
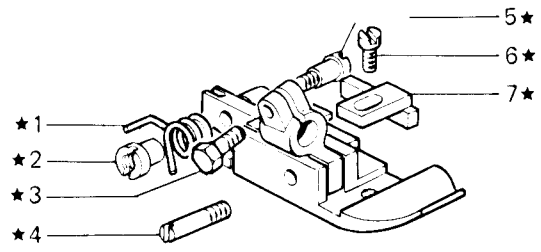

Fig. N. Abb. N.	Part. N. Bestell N. Piecce N. Pieza N.	Qt. Anzahl	DESCRIZIONE	DESCRIPTION	DESCRIPTION	BENENNUNG	DESCRIPCION
★	205085-3-11	1	piedino completo	presserfoot assembly	pied-presseur complet		
1	204894-0-11	1	molla	spring	ressort		
2	204895-0-11	1	bussola filettata	bush	bague		
3	204947-0-10	1	vite	screw	vis		
4	204869-0-11	1	perno filettato	pin	pivot		
5	204889-0-10	1	vite	screw	vis		
6	741433-2-00	1	vite	screw	vis		
7	205088-0-11	1	linguetta	tongue	languette		
8	208092-0-00	1	placca ago larg. costa 3 mm.	needle plate width bight 3 mm.	plaque à aiguille largeur surjet 3 mm.		
9	204819-0-10	1	griffino	feed dog	petite griffe		
10	204817-0-10	1	griffa sussidiaria	subsidiary feed dog	griffe subsidiaire		
11	208076-0-00	1	griffa principale	main feed dog	griffe principale		
12	207003-2-00	1	coltello superiore	upper knife	couteau supérieur		
13	207020-2-01	1	coltello inferiore	lower knife	couteau inférieur		
14	204033-0-10	1	crochet superiore	upper looper	crochet supérieur		
15	202413-0-11	1	crochet inferiore	lower looper	crochet inférieur		
16	207722-0-01	1	crochet punto sicurezza	safety stitch looper	crochet point de sûreté		
17	202092-0-11	1	crochet superiore cieco	upper blind looper	crochet supérieur aveugle		
18	204905-0-10	1	squadretta	bracket	équerre		
19	721443-2-00	1	vite	screw	vis		
20	741431-0-00	1	vite	screw	vis		
21	204863-0-11	1	spingi asola	front needle guard	pare-boucle		
22	204861-0-10	1	salva ago	rear needle guard	protège-aiguille		
23	204862-4-11	1	gruppo spingi asola e salva ago	front and rear needle guard ass.	groupe pare-boucle et protège-aiguille		
24	740230-2-00	2	vite	screw	vis		
25	780200-0-40	1	targhetta classe testa	head class plate	plaque classe tête		
			SOLO A RICHIESTA	ONLY ON REQUEST	SEULEMENT SUR DEMANDE		
12	203759-0-10	1	coltello superiore	upper knife	couteau supérieur		
	203783-0-10	1	coltello superiore	upper knife	couteau supérieur		
	207004-2-00	1	coltello superiore	upper knife	couteau supérieur		
13	204693-0-11	1	coltello inferiore	lower knife	couteau inférieur		
15	Tav. 11 205080-0-10	1	spingi asola	front needle guard	pare-boucle		

Fig. N. Abb. N.	Part. N. Bestell N. Piece N. Pieza N.	Qt. Anzahl	DESCRIZIONE	DESCRIPTION	DESCRIPTION	BENENNUNG	DESCRIPCION
▲ 7	Tav. 5 206927-4-00 206701-2-01	1 1	albero principale con cuscinetti albero principale	main shaft with bearing main shaft	arbre princ. avec coussinet arbre principal		
▲ 25 38 39	Tav. 9 207514-4-00 207524-2-00 207543-0-00 765510-6-10	1 1 1 2	morsetto porta aghi completo morsetto porta aghi guidafilo ago RIM 29A fin. 100	needles clamp assembly needles clamp thread guide needle RIM 29 A size 100	porte-aiguilles complet porte-aiguilles guide-fil aiguille RIM 29A jauge 100		



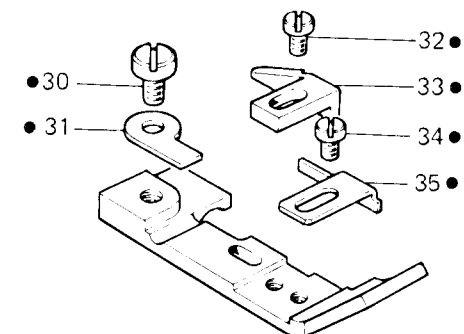
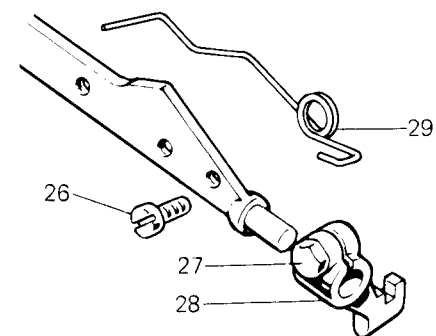
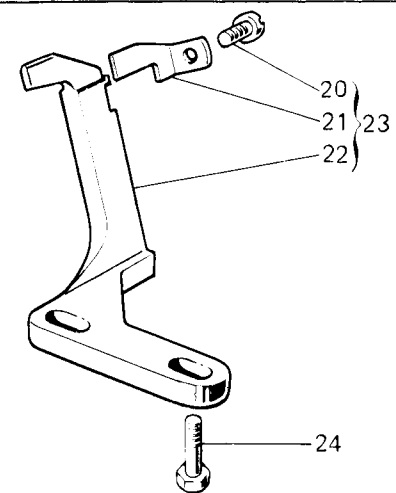
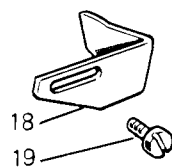
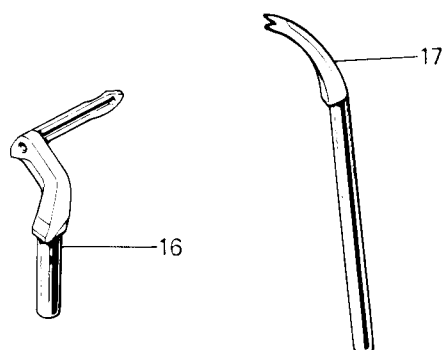
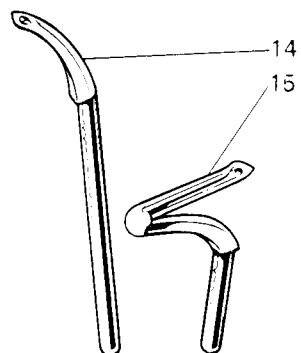
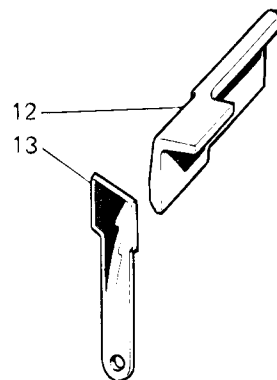
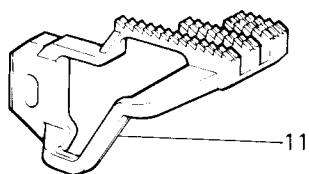
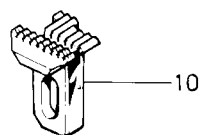
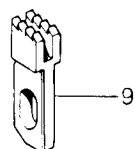
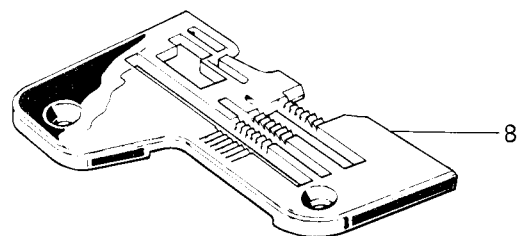
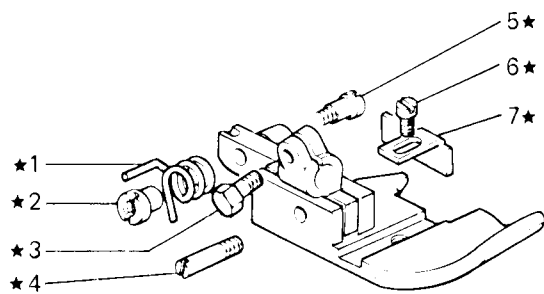

Fig. N. Abb. N.	Part. N. Bestell N. Piece N. Pieza N.	Qt. Anzahl	DESCRIZIONE	DESCRIPTION	DESCRIPTION	BENENNUNG	DESCRIPCION
★	206002-3-02	1	piedino completo	presserfoot assembly	pied-presseur complet		
1	204894-0-11	1	molla	spring	ressort		
2	204895-0-11	1	bussola filettata	bush	bague		
3	204947-0-10	1	vite	screw	vis		
4	204869-0-11	1	spina filettata	pin	goupille		
5	204889-0-10	1	vite	screw	vis		
6	741413-2-00	1	vite	screw	vis		
7	204878-0-11	1	piastrina	plate	plaque		
8	204864-0-13	1	placca ago larg. costa 5 mm.	needle plate width bight 5 mm	plaque à aiguille largeur surjet 5 mm.		
9	202609-0-10	1	griffino	feed dog	pet te griffe		
10	204943-0-11	1	griffa sussidiaria	subsidiary feed dog	griffe subsidiaire		
11	204941-0-11	1	griffa principale	main feed dog	griffe principale		
12	207003-2-00	1	coltello superiore	upper knife	couteau supérieur		
13	207020-2-01	1	coltello inferiore	lower knife	couteau inférieur		
14	204033-0-10	1	crochet superiore	upper looper	crochet supérieur		
15	202413-0-11	1	crochet inferiore	lower looper	crochet inférieur		
16	207722-0-01	1	crochet punto sicurezza	safety stitch looper	crochet point de sûreté		
17	202092-0-11	1	crochet superiore cieco	upper blind looper	crochet supérieur aveugle		
18	204905-0-10	1	squadretta	bracket	équerre		
19	721443-2-00	1	vite	screw	vis		
20	741431-0-00	1	vite	screw	vis		
21	204863-0-11	1	salva ago	front needle guard	protège-aiguille		
22	204861-0-10	1	spingi asola	rear needle guard	pare-boucle		
23	204862-4-11	1	gruppo salva ago e spingi asola	front and rear needle guard ass.	groupe protège-aiguille et pare-boucle		
24	740230-2-00	2	vite	screw	vis		
25	781312-0-40	1	targhetta classe testa	head class plate	plaque classe tête		
			<b>SOLO A RICHIESTA</b>	<b>ONLY ON REQUEST</b>	<b>SEULEMENT SUR DEMANDE</b>		
●	206482-3-00	1	piedino completo	presserfoot assembly	pied-presseur complet		
8	204948-0-12	1	placca ago larg. costa 4 mm.	needle plate width bight 4 mm.	plaque à aiguille largeur surjet 4 mm.		
10	204850-0-10	1	griffa sussidiaria	subsidiary feed dog	griffe subsidiaire		
	204851-0-11	1	griffa sussidiaria	subsidiary feed dog	griffe subsidiaire		
	204942-0-10	1	griffa sussidiaria	subsidiary feed dog	griffe subsidiaire		
11	204846-0-11	1	griffa principale	main feed dog	griffe principale		
	204940-0-11	1	griffa principale	main feed dog	griffe principale		
	204997-0-01	1	griffa principale	main feed dog	griffe principale		
12	203759-0-10	1	coltello superiore	upper knife	couteau supérieur		
	203783-0-10	1	coltello superiore	upper knife	couteau supérieur		
	207004-2-00	1	coltello superiore	upper knife	couteau supérieur		
13	204693-0-11	1	coltello inferiore	lower knife	couteau inférieur		
26	743134-0-00	1	vite	screw	vis		
27	204947-0-10	1	vite	screw	vis		
28	206641-2-00	1	attacco premistoffa	coupling	collier		
29	206486-0-00	1	molla premi piedino	spring	ressort		
30	741665-2-00	1	vite	screw	vis		
31	204070-0-10	1	staffa	bracket	bride		
32	741453-2-00	1	vite	screw	vis		
33	206483-0-00	1	linguetta	tongue	languette		
34	741433-2-00	1	vite	screw	vis		
35	206484-0-00	1	piastrina	plate	plaque		

Fig. N. Abb. N.	Part. N. Bestell N. Pieze N.	Qt. Anzahl	DESCRIZIONE	DESCRIPTION	DESCRIPTION	BENENNUNG	DESCRIPCION
	<u>Tav. 9</u>						
▲	207514-4-00	1	morsetto porta aghi completo	needles clamp assembly	porte-aiguilles complet		
25	207524-2-00	1	morsetto porta aghi	needles clamp	porte-aiguilles		
38	207544-0-00	1	guidafilo	thread guide	guide-fil		
	<u>Tav. 10</u>						
■	207885-4-00	1	leva premistoffa con perno	presser lever with pin	levier du pied-presseur avec pivot		
15	205823-0-01	1	leva	lever	levier		
			PEZZI ANNULLATI	CANCELLED PARTS	PIECES ANNULEES		
16	204891-0-11	1	molla premi piedino	spring	ressort		
17	203187-0-10	1	vite	screw	vis		

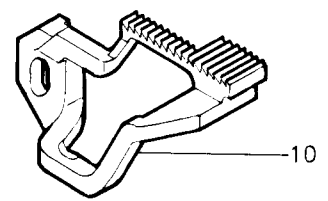
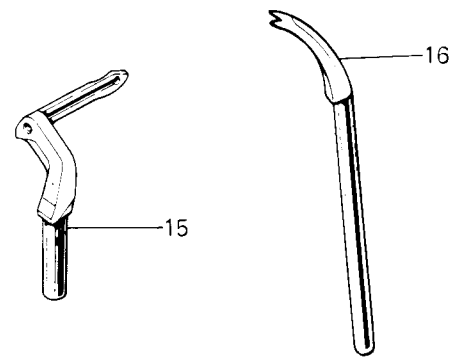
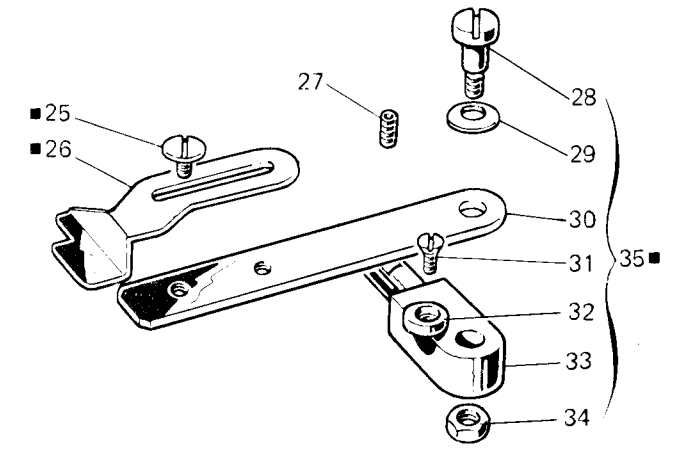
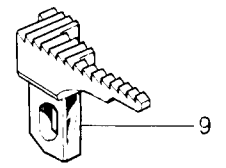
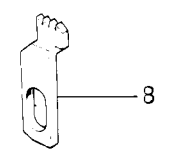
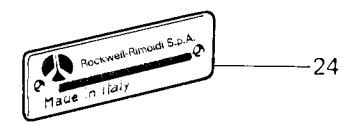
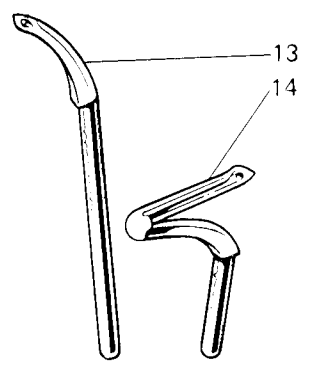
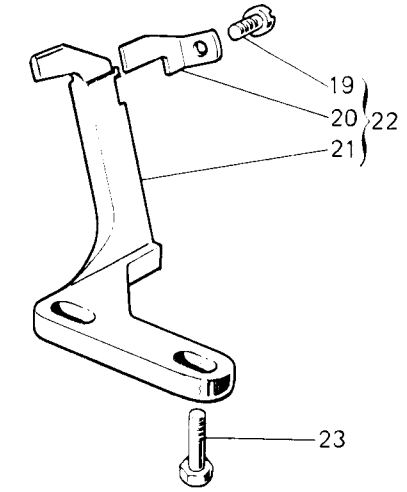
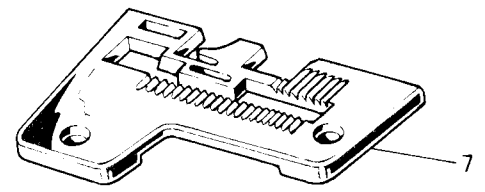
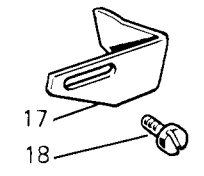
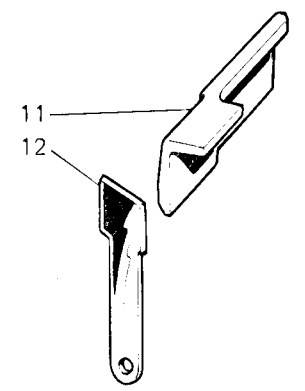
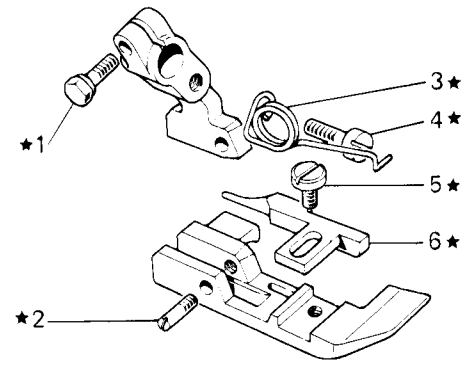

Fig. N. Abb. N.	Part. N. Piecce N. Bestell. N. Pieza N.	Qt. Anzahl	DESCRIZIONE	DESCRIPTION	DESCRIPTION	BENENNUNG	DESCRIPCION
★	205824-3-00	1	pedino completo	presserfoot assembly	pied-presseur complet		
1	204947-0-10	1	vite	screw	vis		
2	204869-0-11	1	spina filettata	pin	goupille		
3	205822-0-00	1	molla	spring	ressort		
4	741654-2-00	1	vite	screw	vis		
5	721411-2-00	1	vite	screw	vis		
6	205820-0-00	1	linguetta	tongue	languette		
7	205816-0-00	1	placca ago larg. costa 3,7 mm	needle plate width bight 3,7 mm	plaque à aiguille largeur surjet 3,7 mm		
8	205830-0-00	1	griffino	feed dog	pétite griffe		
9	205818-0-00	1	griffa sussidiaria	subsidiary feed dog	griffe subsidiaire		
10	205817-0-01	1	griffa principale	main feed dog	griffe principale		
11	203783-0-10	2	coltello superiore	upper knife	couteau supérieur		
12	204693-0-11	2	coltello inferiore	lower knife	couteau inférieur		
13	204033-0-10	1	crochet superiore	upper looper	crochet supérieur		
14	202413-0-11	1	crochet inferiore	lower looper	crochet inférieur		
15	207722-0-01	1	crochet punto sicurezza	safety stitch looper	crochet point de sûreté		
16	202092-0-11	1	crochet superiore cieco	upper blind looper	crochet supérieur aveugle		
17	204905-0-10	1	squadretta	bracket	équerre		
18	721443-2-00	1	vite	screw	vis		
19	741431-0-00	1	vite	screw	vis		
20	204863-0-11	1	salva ago	rear needle guard	protège-aiguille		
21	204861-0-10	1	spingi asola	front needle guard	pare-boucle		
22	204862-4-11	1	gruppo spingi asola e salva ago	front and rear needle guard ass.	groupe pare-boucle et protège-aiguille		
23	740230-2-00	2	vite	screw	vis		
24	781315-0-40	1	targhetta classe testa	head class plate	plaque classe tête		
			SOLO A RICHIESTA	ONLY ON REQUEST	SEULEMENT SUR DEMANDE		
★	205814-3-00	1	pedino completo	presserfoot assembly	pied-presseur complet		
■	204919-4-10	1	guida completa	guide assembly	guide complète		
6	205813-0-00	1	linguetta	tongue	languette		
7	205815-0-00	1	placca ago larg. costa 5,5 mm	needle plate width bight 5,5 mm	plaque à aiguille largeur surjet 5,5 mm		
11	203759-0-10	1	coltello superiore	upper knife	couteau supérieur		
	207003-2-00	1	coltello superiore	upper knife	couteau supérieur		
	207004-2-00	1	coltello superiore	upper knife	couteau supérieur		
12	207020-2-01	1	coltello inferiore	lower knife	couteau inférieur		
25	201236-0-10	2	vite	screw	vis		
26	204920-0-20	1	guida	guide	guide		
27	729013-2-00	1	vite	screw	vis		
28	743464-2-00	1	vite	screw	vis		
29	702406-0-00	1	molla a tazza	cup spring	ressort à tasse		
30	204647-0-00	1	supporto	support	support		
31	744634-0-00	1	vite	screw	vis		
32	300710-0-10	1	eccentrico	eccentric	excentrique		
33	202970-0-10	1	sostegno	support	support		
34	746007-2-00	1	dado	nut	écrou		
35	204960-4-00	1	sostegno completo	support assembly	support complet		

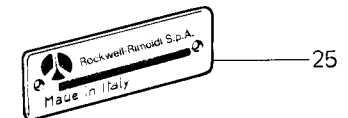
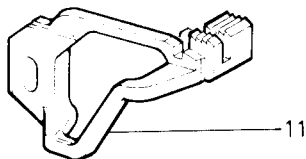
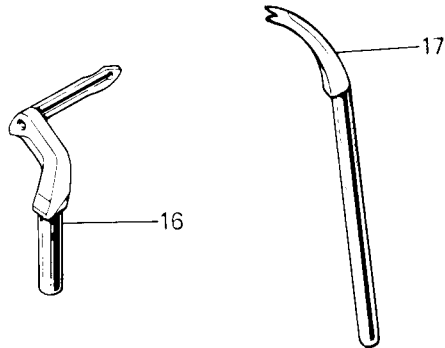
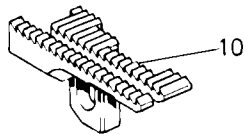
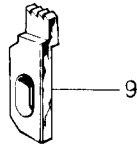
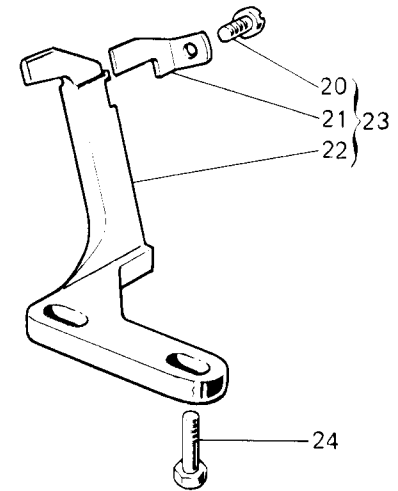
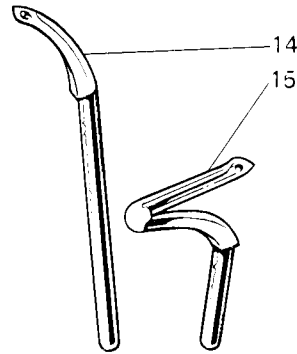
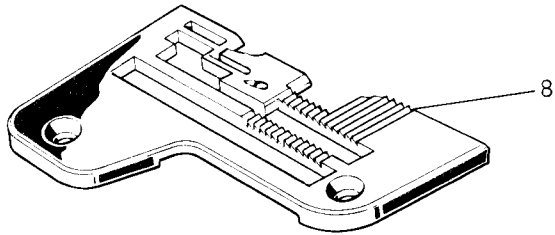
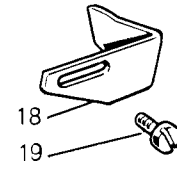
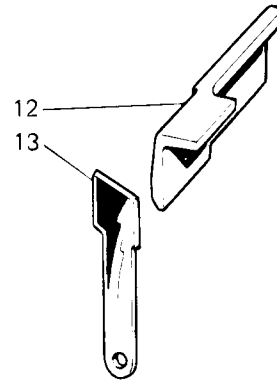
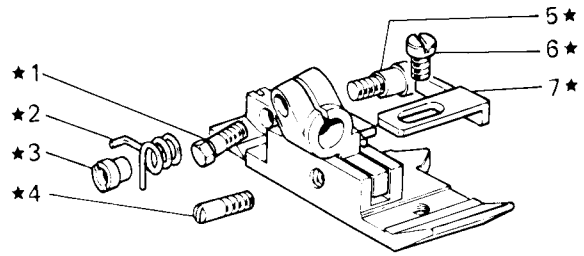

Fig. N. Abb. N.	Part. N. Piece N. Bestell N. Pieza N.	Qt. Anzahl	DESCRIZIONE	DESCRIPTION	DESCRIPTION	BENENNUNG	DESCRIPCION
★	204828-3-11	1	piedino completo	presser foot assembly	pied-presseur complet		
1	204947-0-10	1	vite	screw	vis		
2	204894-0-11	1	molla	spring	ressort		
3	204895-0-11	1	bussola filettata	bush	bage		
4	204869-0-11	1	spina filettata	pin	goupille		
5	204889-0-10	1	vite	screw	vis		
6	741431-2-00	1	vite	screw	vis		
7	204880-0-11	1	piastrina	plate	plaque		
8	208041-0-00	1	placca ago larg. costa 3 mm	needle plate width bight 3 mm	plaque à aiguille largeur surjet 3 mm		
9	204819-0-10	1	griffino	feed dog	petite griffe		
10	204818-0-11	1	griffa sussidiaria	subsidiary feed dog	griffe subsidiaire		
11	208040-0-00	1	griffa principale	main feed dog	griffe principale		
12	203783-0-10	2	coltello superiore	upper knife	couteau supérieur		
13	204693-0-11	2	coltello inferiore	lower knife	couteau inférieur		
14	204033-0-10	1	crochet superiore	upper looper	crochet supérieur		
15	202413-0-11	1	crochet inferiore	lower looper	crochet inférieur		
16	207722-0-01	1	crochet punto sicurezza	safety stitch looper	crochet point de sûreté		
17	202092-0-11	1	crochet superiore cieco	upper blind looper	crochet supérieur aveugle		
18	204905-0-10	1	squadretta	bracket	équerre		
19	721443-2-00	1	vite	screw	vis		
20	741431-0-00	1	vite	screw	vis		
21	204863-0-11	1	salva ago	rear needle guard	protège-aiguille		
22	204861-0-10	1	spingi asola	front needle guard	pare-boucle		
23	204862-4-11	1	gruppo spingi asola e salva ago	front and rear needle guard ass.	groupe pare-boucle et protège-aiguille		
24	740230-2-00	2	vite	screw	vis		
25	780200-0-40	1	targhetta classe testa	head class plate	plaque classe tête		
			SOLO A RICHIESTA	ONLY ON REQUEST	SEULEMENT SUR DEMANDE		
12	203759-0-10	1	coltello superiore	upper knife	couteau supérieur		
	207003-2-00	1	coltello superiore	upper knife	couteau supérieur		
	207004-2-00	1	coltello superiore	upper knife	couteau supérieur		
13	207020-2-01	1	coltello inferiore	lower knife	couteau inférieur		
39	<u>Tav. 9</u> 765510-6-90	2	ago RIM 29A fin. 90	needle RIM 29A size 90	aiguille RIM 29A jauge 90		
15	<u>Tav. 11</u> 204820-0-10	1	spingi asola	front needle guard	pare-boucle		
			PEZZI ANNULLATI	CANCELLED PARTS	PIECES ANNULEES		
28	<u>Tav. 2</u> 202398-0-10	1	tappo	plug	bouchon		
16	<u>Tav. 10</u> 204891-0-11	1	molla premi piedino	spring	ressort		
17	203187-0-10	1	vite	screw	vis		

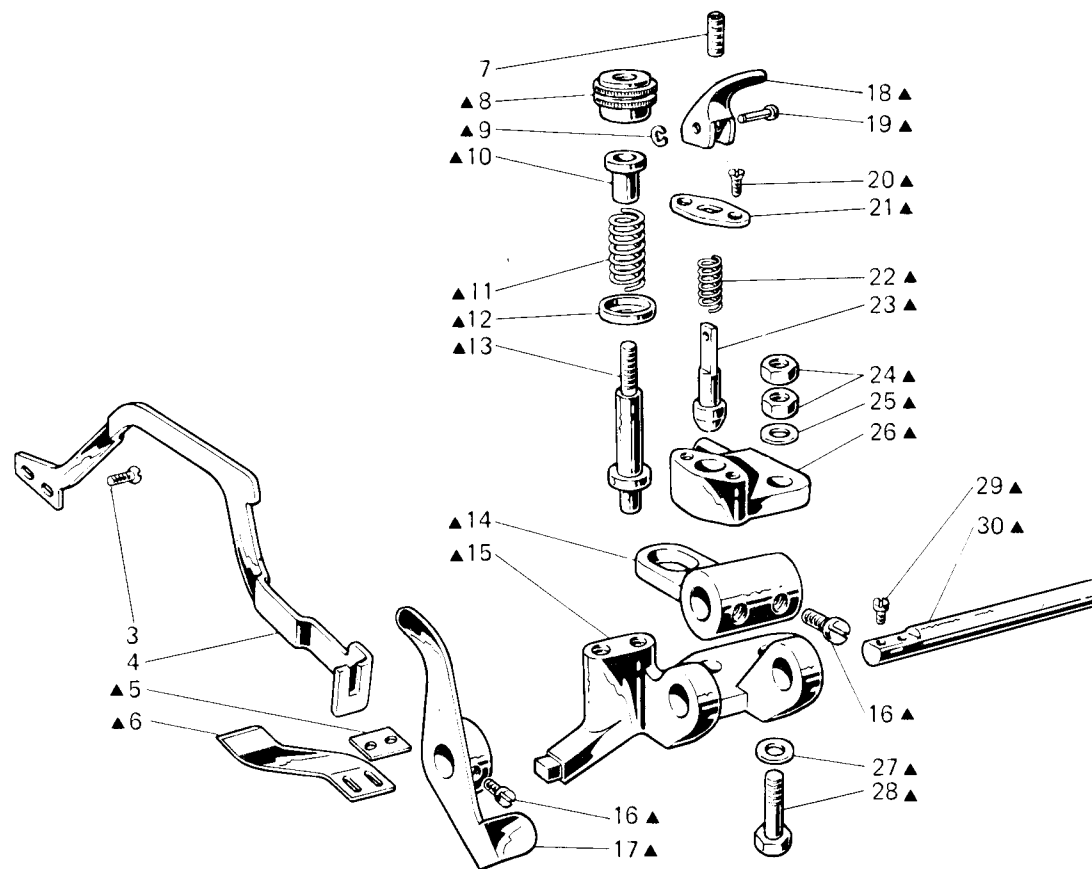
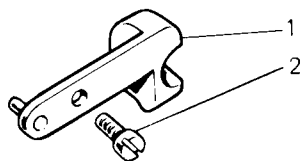



Fig. N. Abb. N.	Part. N. Piece N. Bestell N. Pieza N.	Qt. Anzahl	DESCRIZIONE	DESCRIPTION	DESCRIPTION	BENENNUNG	DESCRIPCION
▲	204915-4-13	1	pieghettatore completo	folding device	disp. du plissage		
1	203193-2-10	1	squadretta di fermo	bracket	équerre		
2	721443-2-00	1	vite	screw	vis		
3	720431-2-00	2	vite	screw	vis		
4	<del>208058-0-00</del> 204964-0-00	1	leva pieghettatore	folding lever	levier du plissage		
5	204964-0-00	1	piastrina	sheet	plaquette		
6	205468-0-00	1	lamina	sheet	plaque		
	205469-0-00	1	lamina	sheet	plaque		
7	729013-2-00	1	vite	screw	vis		
8	200699-0-10	1	pomolo	knob	pommeau		
9	700205-0-00	1	anello	ring	anneau		
10	200074-0-10	1	bussola	bush	bague		
11	204937-0-10	1	molla	spring	ressort		
12	200821-0-10	1	scodellino	cup	cuvette		
13	200698-0-10	1	perno	pin	pivot		
14	204926-0-10	1	leva	lever	levier		
15	204914-0-10	1	corpo pieghettatore	folding device body	corps du plissage		
16	721434-2-00	4	vite	screw	vis		
17	204924-2-10	1	leva	lever	levier		
18	206909-0-00	1	leva	lever	levier		
19	202100-0-10	1	spina	pin	goupille		
20	744533-0-00	2	vite	screw	vis		
21	204935-0-10	1	piastrina	plate	plaque		
22	204938-0-10	1	molla	spring	ressort		
23	204936-0-10	1	puntale	pin	pivot		
24	746021-2-00	2	dado	nut	écrou		
25	704216-2-00	1	rondella	washer	rondelle		
26	204927-0-10	1	sostegno	support	support		
27	704424-2-00	1	rondella	washer	rondelle		
28	204934-0-10	1	vite a perno	screw	vis		
29	741675-2-00	2	vite	screw	vis		
30	204918-0-10	1	perno	pin	pivot		

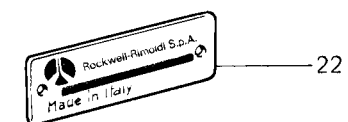
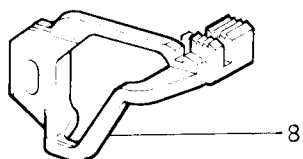
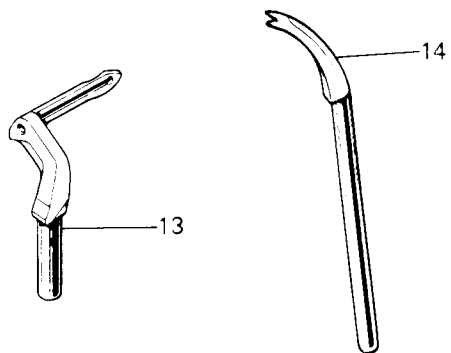
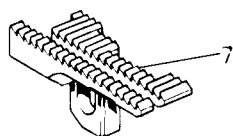
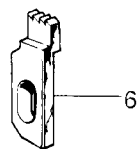
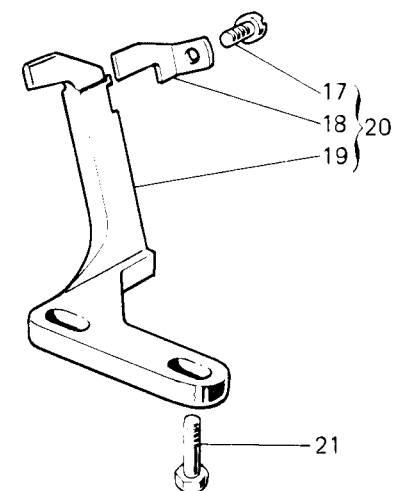
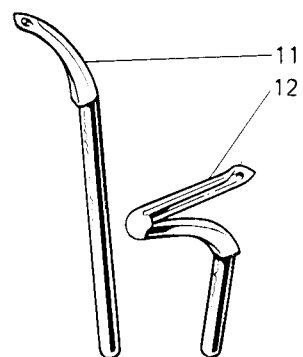
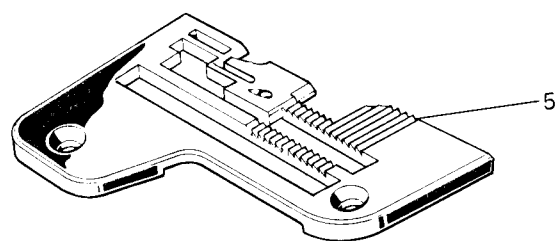
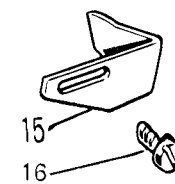
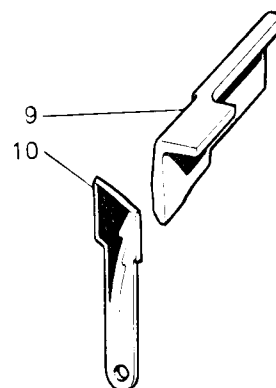
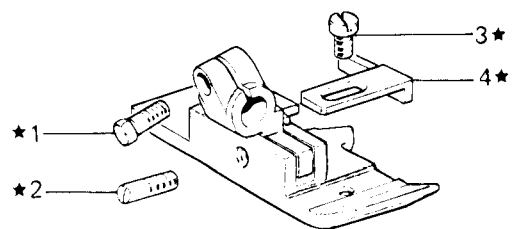

Fig. N. Abb. N.	Part. N. Piecce N. Bestell N. Pieza N.	Qt. Anzahl	DESCRIZIONE	DESCRIPTION	DESCRIPTION	BENENNUNG	DESCRIPCION
▲	204915-4-13	1	pieghettatore completo	folding device	disp. du plissage		
1	203193-2-10	1	squadretta di fermo	bracket	équerre		
2	721443-2-00	1	vite	screw	vis		
3	720431-2-00	2	vite	screw	vis		
4	208058-0-00	1	leva pieghettatore	folding lever	levier du plissage		
5	204964-0-00	1	piastrina	sheet	plaquette		
6	205468-0-00	1	lamina	sheet	plaque		
	205469-0-00	1	lamina	sheet	plaque		
7	729013-2-00	1	vite	screw	vis		
8	200699-0-10	1	pomolo	knob	pommeau		
9	700205-0-00	1	anello	ring	anneau		
10	200074-0-10	1	bussola	bush	bague		
11	204937-0-10	1	molla	spring	ressort		
12	200821-0-10	1	scodellino	cup	cuvette		
13	200698-0-10	1	perno	pin	pivot		
14	204926-0-10	1	leva	lever	levier		
15	204914-0-10	1	corpo pieghettatore	folding device body	corps du plissage		
16	721434-2-00	4	vite	screw	vis		
17	204924-2-10	1	leva	lever	levier		
18	206909-0-00	1	leva	lever	levier		
19	202100-0-10	1	spina	pin	goupille		
20	744533-0-00	2	vite	screw	vis		
21	204935-0-10	1	piastrina	plate	plaque		
22	204938-0-10	1	molla	spring	ressort		
23	204936-0-10	1	puntale	pin	pivot		
24	746021-2-00	2	dado	nut	écrou		
25	704216-2-00	1	rondella	washer	rondelle		
26	204927-0-10	1	sostegno	support	support		
27	704424-2-00	1	rondella	washer	rondelle		
28	204934-0-10	1	vite a perno	screw	vis		
29	741675-2-00	2	vite	screw	vis		
30	204918-0-10	1	perno	pin	pivot		
31	721444-2-00	2	vite	screw	vis		
32	204930-2-10	1	guida	guide	guide		
33	991590-2-00	1	piatto con viti	disc with screw	plateau avec vis		
34	723266-2-00	3	viti	screw	vis		
35	311408-0-00	1	rondella	washer	rondelle		
36	991581-2-00	1	anello con vite	ring with screw	anneau avec vis		
37	991321-2-00	1	supporto	support	support		
38	731107-0-00	2	vite da legno	screw	vis		
39	991589-4-00	1	porta rotolo completo	roll carrier assembly	porte-rouleau complet		
			SOLO A RICHIESTA	ONLY ON REQUEST	SEULEMENT SUR DEMANDE		
32	204958-2-10	1	guida	guide	guide		

Fig. N. Abb. N.	Part. N. Piece N. Bestell N. Pieza N.	Qt. Anzahl	DESCRIZIONE	DESCRIPTION	DESCRIPTION	BENENNUNG	DESCRIPCION
★	204829-3-11	1	pedino completo	presserfoot assembly	ped-presseur complet		
1	204947-0-10	1	vite	screw	vis		
2	204869-0-11	1	spina filettata	pin	goupille		
3	741431-2-00	1	vite	screw	vis		
4	204881-0-11	1	piastrina	plate	plaque		
5	208041-0-00	1	placca ago larg. costa 3 mm	needle plate width bight 3 mm	plaque à aiguille largeur surjet 3 mm		
6	204819-0-10	1	griffino	feed dog	petite griffe		
7	204818-0-11	1	griffa sussidiaria	subsidiary feed dog	griffe subsidiaire		
8	208040-0-00	1	griffa principale	main feed dog	griffe principale		
9	203783-0-10	2	coltello superiore	upper knife	couteau supérieur		
10	204693-0-11	2	coltello inferiore	lower knife	couteau inférieur		
11	204033-0-10	1	crochet superiore	upper looper	crochet supérieur		
12	202413-0-11	1	crochet inferiore	lower looper	crochet inférieur		
13	207722-0-01	1	crochet punto sicurezza	safety stitch looper	crochet point de sûreté		
14	202092-0-11	1	crochet superiore cieco	upper blind looper	crochet supérieur aveugle		
15	204905-0-10	1	squadretta	bracket	équerre		
16	721443-2-00	1	vite	screw	vis		
17	741431-0-00	1	vite	screw	vis		
18	204863-0-11	1	salva ago	rear needle guard	protège-aiguille		
19	204861-0-10	1	spingi asola	front needle guard	pare-boucle		
20	204862-4-11	1	gruppo spingi asola e salva ago	front and rear needle guard ass.	groupe pare-boucle et protège-aiguille		
21	740230-2-00	2	vite	screw	vis		
22	780200-0-40	1	targhetta classe testa	head class plate	plaque classe tête		
			SOLO A RICHIESTA	ONLY ON REQUEST	SEULEMENT SUR DEMANDE		
9	203759-0-10	1	coltello superiore	upper knife	couteau supérieur		
	207003-2-00	1	coltello superiore	upper knife	couteau supérieur		
	207004-2-00	1	coltello superiore	upper knife	couteau supérieur		
10	207020-2-01	1	coltello inferiore	lower knife	couteau supérieur		
39	<u>Tav. 9</u> 765510-6-90	2	ago RIM 29A fin. 90	needle RIM 29A size 90	aiguille RIM 29A jauge 90		
15	<u>Tav. 11</u> 204820-0-10	1	spingi asola	front needle guard	pare-boucle		
			PEZZI ANNULLATI	CANCELLED PARTS	PIECES ANNULEES		
28	<u>Tav. 2</u> 202398-0-10	1	tappo	plug	bouchon		
16	<u>Tav. 10</u> 204891-0-11	1	molla premi pedino	spring	ressort		
17	203187-0-10	1	vite	screw	vis		

