

527-00-1CD-01	527-01-1CD-02	527-23-1CD-02
527-00-1CD-02	527-01-1CD-04	527-28-1CD-02
527-00-1CD-07	527-01-1CD-05	527-28-1CD-09
527-00-1CD-20	527-01-1CD-09	527-29-1CD-01
527-00-1CD-21	527-10-1CD-02	527-29-1CD-02
527-00-1CD-25	527-10-1CD-06	527-29-1CD-05
527-00-1CD-26	527-16-1CD-01	527-29-1CD-06
527-00-1CD-29	527-22-1CD-02	527-30-1CD-07
527-00-1CD-31	527-22-1CD-03	527-34-1CD-01
527-01-1CD-01	527-22-1CD-04	527-38-1CD-01

1a EDIZIONE - EDITION 11/83 **n. 224**

ISTRUZIONI PER LA CONSULTAZIONE DEL CATALOGO

Tutti i particolari delle teste sono rappresentati in più tavole come indicato nell'indice.

Quando i particolari rappresentati in una tavola sono **comuni a tutte le teste riportate nel catalogo**, sulla tavola e nell'indice **non sono indicati i simboli delle teste** poiché sono gli stessi riportati sulla copertina.

Eventuali varianti sono rappresentate in un riquadro sulla medesima tavola, con l'indicazione delle teste a cui si riferiscono.

Quando i particolari rappresentati in una tavola **non sono comuni a tutte le teste riportate nel catalogo**, la tavola viene ripetuta più volte con lo stesso numero seguito da una lettera.

Sulla tavola e nell'indice (di fianco alla descrizione della tavola) **sono indicate le teste interessate**. Eventuali varianti sono rappresentate in un riquadro sulla medesima tavola, con l'indicazione delle teste a cui si riferiscono.

- 1) tutti i particolari non fornibili scolti non vengono richiamati singolarmente ma soltanto illustrati nel gruppo d'appartenenza.
- 2) I numeri riguardanti le figure dei particolari che compongono il gruppo sono di norma raggruppati in una parentesi. In alcuni casi però, dove non è possibile il raggruppamento, i numeri sono affiancati dallo stesso segno particolare (es. ★▲●■ ecc.) con cui è indicato l'intero gruppo.

I particolari a richiesta rappresentati nelle tavole sono contrassegnati con la voce "A RICHIESTA".

Le teste su cui tali particolari possono essere montati sono indicate nelle descrizioni della tavola.

Per facilitare la ricerca viene riportato l'elenco di tutti i particolari illustrati sul Catalogo Base, con la relativa tavola in cui gli stessi sono richiamati.

AGHI

Gli aghi sono contraddistinti dal sistema e dalla finezza.

Il sistema dell'ago e la finezza sono marcati oltre che sulla busta, anche sull'ago stesso. Nelle ordinazioni precisare, oltre al simbolo, il sistema e la finezza degli aghi desiderati. In caso di dubbio allegare un ago campione o una bustina vuota.

IMPORTANTE

Nella richiesta di parti di ricambio citare sempre il relativo numero della testa, il numero della tavola e il simbolo del particolare con relativa descrizione usata sul catalogo.

INSTRUCTIONS TO CONSULT THE CATALOGUE

All the spare parts are illustrated in several tables as indicated in the index.

When the parts illustrated in one table are **common to all the heads listed in the catalogue**, the symbols of the heads, have not been indicated on the table and in the index because they are listed on the cover.

Eventual variations are illustrated in a square on the same table, with the indication of the heads to whom it refers.

When the parts illustrated in one table **are not common to all the heads listed in the catalogue**, the table is reproduced several times with the same reference number followed by a letter.

The heads concerned have been indicated on the table and in the index (by the side of the description of the table).

Eventual variations are illustrated in a square on the same table, with the indication of the heads to whom it refers.

- 1) all parts which cannot be supplied by themselves are not indicated alone, but shown together with the group to which they belong.
- 2) The references of the pictures of the parts making up the group are usually put in brackets. In some cases, however, when their grouping is not possible, the numbers of the various parts in the tables are marked with the same particular sign (for ex. ★▲●■ etc.) with which the whole group is indicated.

The parts on request illustrated on the tables have the indication "ON REQUEST".

The heads on which those parts can be fitted are indicated in the description of the table.

NEEDLES

The needles are marked with system and size.

The system and size of the needle are shown on the packet as well as on the needle itself. When ordering please state symbol, system and size. If you have doubts, enclose a sample needle or an empty packet with your order.

ATTENTION

When ordering spare parts always state the serial number of the machine, the symbol of the part in question and the description given in the catalogue.

INSTRUCTIONS POUR LA CONSULTATION DU CATALOGUE

Toutes les pièces des têtes sont représentées en plusieurs tables comme nous avons indiqué dans l'index.

Quand les pièces représentées dans une table **sont communes à toutes les têtes mentionnées dans le catalogue**, sur la table et dans l'index **ne sont pas indiqués les symboles des têtes** car ce sont les mêmes imprimés sur la couverture.

Les modifications éventuelles sont indiquées dans un panneau sur la table même avec l'indication des têtes auxquelles elles se réfèrent.

Quand les pièces représentées dans une table **ne sont pas communes à toutes les têtes mentionnées dans le catalogue**, la table est publiée plusieurs fois avec les mêmes chiffres suivis d'une lettre. **Sur la table et dans l'index** (à côté de la description de la table) **sont indiquées les têtes intéressées**. Les modifications éventuelles sont indiquées dans un panneau sur la table même avec l'indication des têtes auxquelles elles se réfèrent.

- 1) toutes les pièces qui ne sont pas fournies séparément mais qui font partie d'un groupe, ne sont pas indiquées séparément.
- 2) Les symboles des pièces qui forment un groupe sont regroupés entre parenthèses. Cependant, lorsque ceci n'a pas été possible, les symboles, qui dans les tables d'illustration correspondent aux pièces, sont suivis du même signe particulier (ex. ★▲●■ etc.) qui indique le groupe tout entier.

Les pièces sur demande représentées dans les tables sont marquées avec la mention "SUR DEMANDE".

Pour faciliter la recherche, le catalogue renferme l'index numérique de toutes les pièces illustrées avec indication de la table dans laquelle elles sont indiquées.

AIGUILLES

Les aiguilles se différencient par le système et la grosseur.

Le système de l'aiguille et sa grosseur, sont indiqués non seulement sur le sachet mais également sur l'aiguille. Dans l'ordre préciser, en plus du symbole, le système et la grosseur des aiguilles désirés. En cas de doute, joindre une aiguille comme modèle ou un sachet vide.

ATTENTION

En cas d'ordre de pièces détachées indiquer toujours le numéro de la machine, le symbole de la pièce et la dénomination officielle mentionnée sur le catalogue.

INDICE

INDEX

TAV. N. TAB. N.	DESCRIZIONE	DESCRIPTION	DESCRIPTION
1	SPORTELLO E CARTER ANTERIORE	COVER AND FRONT CARTER	COUVERCLE ET CARTER AVANT
2/A-B	COPERCHIO CON TENS. E PASSAFILI	COVER WITH TENS. AND THREAD GUIDE	COUVERCLE AVEC TENSION ET PASSE-FILS
3	ALBERO PRINCIPALE	MAIN SHAFT	ARBRE PRINCIPAL
4	COMANDO GRIFFA CON ECCENTRICO REG.	FEED DOG CONTROL WITH ECCENTRIC	COMM. GRIFFE AVEC EXCENTRIQUE
5	GR. MANIC. E PORTA CROCHET INF. SUP	COUPLING ASS. AND UPPER-LOWER LOOPER	GROUPE MANCHON ET CROCHET SUP. - INF.
6	CINEMATISMO BARRA AGO	NEEDLE BAR CONTROL	CINEMATISME BARRE AIGUILLE
7	SUPPORTO E LEVA PREMISTOFFA	SUPPORT AND PRESSER LEVER	SUPPORT ET LEVIER PRESSE-TISSUE
8	PORTA COLTELLI	KNIVES HOLDER	PORTE COUTEAUX
9	POMPA E COPERCHIO DISTR. OLIO	PUMP AND COVER FOR OIL DISTR.	POMPE ET COUVERCLE DE DISTR. HUILE
10	BACINELLA OLIO	OIL SUMP	RESERVOIR HUILE
11	ACCESSORI IN DOTAZIONE	AUXILIARY EQUIPMENT	ACCESSOIRES EN DOTATION
12	PIAZZAMENTO SU BANCALE	SETTING ON STAND	PLACEMENT SUR BATI
13	LUBRIFICAZIONE AL SILICONE	SILICONE LUBRICATION	LUBRIFICATION A LA SILICONE
14	PORTA BOBINE	BOBBIN CARRIER	PORTE BOBINES
15/A-B C-D-E-F	RIEPILOGO ORGANI DI CUCITURA	SEWING PARTS SUMMING UP	RECAPITOLATION ORGANES DE COUTURE
16/A-B-C	PLACCHE	PLATES	PLAQUES
17	CROCHET	LOOPER	CROCHET
18/A-B	GRIFFE PRINCIPALI	MAIN FEED DOG	GRIFFE PRINCIPAL
19/A-B	GRIFFE SUSSIDIARIE	SUBSIDIARY FEED DOG	GRIFFE SUBSIDIAIRE
20/A-B C-D	PIEDINI	PRESSERFEET	PIED-PRESSEURS
21	COLTELLI SUPERIORI	UPPER KNIVES	COUTEAUX SUPERIEUR
22	COLTELLI INFERIORI	LOWER KNIVES	COUTEAUX INFERIEUR
23/A-B	RIEPILOGO GUIDE E PORTAROTOLI	GUIDES AND ROLL CARRIER SUMM. UP	RECAPITOLATION GUIDES ET PORTE ROULEAUX
24/A-B	GUIDE	GUIDE	GUIDE
25	SUPPORTI	SUPPORTS	SUPPORTS
26	BLOCCHETTI	BLOCK	BLOC
27	PIEGHETTATORE	FOLDING DEVICE	DISP. DE PLISSAGE
28	GINOCCHIELLO	KNEE-PRESS	GENOUILLERE
29	PORTA ROTOLI	ROLL CARRIER	PORTE-ROULEAUX

INDICE NUMERICO INDEX

Part N	Tav N	Part N	Tav N	Part N	Tav N	Part N	Tav N	Part N	Tav N	Part N	Tav N	Part N	Tav N
100305-0-10	2/A-2/B	202130-0-11	8	202371-0-10	7	202695-0-10	18/A	202967-0-10	25	203173-0-11	20/C	203810-0-10	8
100620-2-10	4	202134-0-11	8	202385-0-10	4	202699-0-10	19/A	202970-0-10	25	203193-2-10	26	203812-0-10	21
200074-0-10	27	202142-0-10	21	202386-0-10	3	202707-0-11	16/A	202974-0-10	24/B	203198-0-10	26	203813-0-11	16/C
200490-0-00	4	202143-0-10	21	202391-0-11	7	202709-0-11	16/A	203001-0-10	18/A	203199-0-10	18/A	203815-3-11	20/C
200662-0-10	8	202146-0-10	22	202398-0-10	9	202716-0-11	16/B	203002-0-10	19/A	203201-2-11	18/B	203816-0-11	20/C
200698-0-10	27	202148-0-11	16/A	202408-0-10	4	202720-0-00	5	203004-0-10	19/B	203212-0-10	25	203817-0-11	20/C
200699-0-13	27	202149-0-11	16/A	202412-0-11	4	202732-3-01	20/B	203012-0-10	22	203214-0-11	16/C	204021-0-10	17
200821-0-10	27	202171-3-11	20/A	202473-0-11	4	202738-4-01	16/B	203014-0-12	16/B	203216-4-11	16/C	204033-0-10	17
201128-0-10	5	202172-3-11	20/A	202475-0-10	4	202757-0-00	18/A	203025-2-00	20/C	203217-0-11	16/C	204122-0-10	3
201162-0-10	25	202173-3-11	20/A	202478-0-10	4	202758-0-00	19/A	203028-0-10	18/A	203218-0-11	16/C	204914-0-10	27
201236-0-10	24/A-24/B	202175-3-11	20/A	202480-0-10	9	202767-4-10	24/B	203030-2-11	18/A	203219-0-11	16/C	204915-4-13	27
201246-0-10	24/B	202176-3-11	20/A	202484-0-10	9	202769-2-00	24/B	203031-0-10	19/A	203220-0-11	16/C	204918-0-10	27
201254-2-10	24/B	202177-3-11	20/A	202488-0-10	4	202772-2-10	24/B	203033-2-11	19/A	203221-0-10	26	204924-2-10	27
201358-0-10	4	202178-3-11	20/A	202489-0-10	4	202774-3-11	20/B	203035-0-11	16/B	203223-4-10	25	204926-0-10	27
201610-0-01	4	202184-0-11	20/A-20/C	202490-0-10	4	202775-0-11	20/B	203037-0-12	16/B	203227-0-10	25	204927-0-10	27
202026-0-10	9		20/B	202492-0-10	3	202776-0-00	24/A	203047-0-21	16/B	203238-0-10	26	204930-2-10	24/A
202027-0-10	9	202192-0-10	20/A-20/B	202504-0-11	16/A	202780-0-10	18/A	203048-0-21	16/B	203239-4-10	26	204934-0-10	27
202032-0-11	4		20/C	202506-4-11	16/A	202782-0-10	19/A	203050-3-11	20/B	203253-0-10	26	204935-0-10	27
202033-0-10	4	202193-0-11	20/A-20/B	202507-0-11	16/A	202783-0-11	16/B	203052-0-11	20/B	203265-0-11	19/A	204936-0-10	27
202053-0-10	18/A	202195-0-11	20/A-20/B	202508-0-11	16/A	202786-3-11	20/B	203060-0-10	18/A	203270-0-10	18/B	204937-0-10	27
202054-0-10	18/A		20/C	202509-3-11	20/A	202789-0-11	20/B	203062-0-10	19/A	203271-0-11	19/A	204938-0-10	27
202056-2-11	18/A	202196-0-11	20/A	202512-4-10	20/A	202795-0-10	20/B-20/C	203066-0-10	21	203280-0-11	16/C	204947-0-10	7
202057-0-10	19/A	202197-0-11	20/A	202517-0-00	18/A	202797-0-11	20/B	203069-0-10	22	203571-0-11	20/C	204964-0-00	27
202058-0-11	19/A	202198-0-11	20/A	202529-0-10	6-7	202800-0-11	20/B-20/D	203072-0-11	16/B	203589-0-10	26	205021-0-10	7
202060-2-11	19/A	202201-0-11	20/A-20/B	202542-0-10	18/A	202805-0-10	24/B	203077-3-11	20/B	203704-0-10	25	205468-0-00	27
202061-0-10	19/B		20/C-20/D	202556-0-01	2/A-2/B	202808-0-10	24/B	203079-2-11	20/B	203705-0-10	25	205469-0-00	27
202062-2-10	5	202214-0-11	1-7	202558-2-01	2/A-2/B	202809-4-10	24/B	203082-0-11	20/B	203706-0-10	24/B	205563-2-10	24/A
202063-0-10	4	202227-0-10	2/A	202559-0-00	19/A	202839-0-11	24/B	203094-2-00	19/A	203707-0-10	24/B	205841-0-00	26
202065-0-20	5	202228-0-10	2/A-2/B	202590-0-11	16/A	202840-4-11	24/B	203095-2-00	18/A	203708-4-11	25	205842-0-00	26
202071-2-20	5	202229-0-10	2/A-2/B	202605-0-10	18/A	202843-0-11	24/B	203135-2-10	2/A	203709-0-11	25	205890-2-00	24/A
202086-0-12	5	202267-2-13	2/A-2/B	202608-0-10	19/A	202847-0-10	24/B	203140-0-10	18/A	203710-0-11	25	205892-3-00	20/C
202087-0-11	20/A	202278-0-10	2/B	202609-0-10	19/B	202851-4-11	24/B	203141-0-10	19/A	203711-4-11	24/B	205951-0-00	18/B
202088-0-11	20/A	202279-0-10	2/A	202634-0-11	16/A	202858-0-10	24/B	203142-0-10	7	203713-0-10	25	205952-0-00	19/B
202090-0-11	17	202280-0-10	2/B	202635-0-11	16/A	202860-0-10	24/B	203144-0-10	22	203714-0-10	25	205954-3-01	20/C
202092-0-11	17	202283-0-10	2/B	202636-0-11	16/A	202862-2-10	24/B	203148-0-11	16/B	203715-0-10	25	205965-0-00	26
202094-0-11	17	202300-0-10	24/B	202642-3-11	20/B	202869-0-10	24/B	203149-0-11	16/C	203716-0-10	25	205966-4-00	26
202095-0-11	17	202302-0-10	16/A-16/B	202643-3-11	20/B	202871-0-10	24/B	203150-0-10	16/C	203765-3-11	20/C	205967-0-00	25
202100-0-10	27		16/C	202648-0-11	20/B	202876-0-11	16/B	203157-3-11	20/B	203768-0-11	20/C-20/D	205968-4-00	25
202118-0-10	7	202303-0-10	26	202660-0-11	20/B	202877-0-11	16/B	203159-3-10	20/C	203771-0-11	20/C	205972-0-00	24/A
202128-0-10	8	202311-2-10	24/A	202661-0-11	20/B	202957-2-10	24/A	203160-3-11	20/C	203772-0-11	20/A-20/C	205973-0-00	24/A
202129-0-10	8	202313-3-10	24/A	202681-0-10	2/A-2/B	202958-4-10	25	203162-3-11	20/C		20/D	205974-0-00	24/A

INDICE NUMERICO INDEX

Part N	Tav N	Part N	Tav N	Part N	Tav N	Part N	Tav N	Part N	Tav N	Part N	Tav N	Part N	Tav N
205975-4-00	24/A	206559-0-01	10	206654-2-10	5	206790-2-11	4	207520-2-00	6	207945-0-00	4	208012-4-01	10
206140-3-02	20/C	206560-0-10	10	206658-2-02	5	206794-0-00	4	207540-0-00	6	207946-0-01	4	208015-0-00	5
206140-4-11	6	206564-0-00	10	206659-2-01	5	206795-0-00	4	207574-0-00	6	207947-0-00	4	208018-0-00	24/A
206142-0-01	20/C	206565-0-01	10	206662-0-00	10	206796-0-00	4	207586-0-00	8	207948-0-00	4	208019-0-00	13
206143-0-00	20/C	206566-0-00	10	206665-2-00	10	206797-0-00	4	207588-0-00	8	207950-4-00	4	208022-2-00	1
206208-0-00	17	206567-0-01	10	206667-0-01	9	206798-0-00	4	207589-0-00	8	207951-4-00	9	208039-4-00	5
206209-0-00	17	206568-0-01	10	206679-0-00	3	206799-0-00	4	207625-0-00	7	207952-2-00	9	208058-0-00	27
206224-0-00	6	206569-0-01	10	206680-0-01	3	206808-0-01	7	207626-0-00	7	207953-0-00	9	208060-4-00	1
206293-2-00	18/B	206574-2-01	8	206682-0-01	3	206810-2-00	7	207692-2-00	6	207954-0-00	9	208063-4-00	1
206295-2-01	19/B	206580-2-00	4	206683-0-00	3	206812-0-00	2/A-2/B	207719-0-00	4	207955-2-01	1	208065-4-00	1
206296-0-00	9	206583-0-00	4	206684-0-00	3	206845-0-01	7	207711-2-10	4	207958-0-01	1	208080-2-00	1
206297-0-01	16/C	206584-2-00	4	206685-0-00	1	206872-0-00	4	207724-2-00	4	207959-0-00	7	208082-2-00	1
206341-4-00	2/A	206586-0-01	4	206686-0-00	5	206875-0-00	4	207758-0-01	9	207960-0-00	7	208084-2-00	1
206342-4-00	2/A-2/B	206587-0-01	4	206687-2-00	9	206909-0-00	27	207856-0-00	1	207961-0-00	9	208087-3-00	9
206343-4-00	2/A-2/B	206588-0-00	4	206688-0-00	9	206974-0-00	3	207858-0-00	1	207962-0-00	7	208090-0-01	2/A-2/B
206350-3-00	20/D	206590-3-00	4	206689-0-01	3	207000-2-00	21	207861-4-00	8	207965-0-00	7	208091-0-01	2/A-2/B
206352-0-01	20/D	206593-0-00	4	206690-2-00	9	207001-2-00	21	207871-0-00	2/B	207967-0-01	7	208097-4-00	4
206386-4-00	5	206594-0-00	4	206692-0-00	3	207006-2-00	21	207872-0-00	2/A	207968-0-01	2/A-2/B	208100-4-00	2/A
206387-4-00	5	206595-0-01	4	206693-0-00	3	207007-2-00	21	207876-2-00	7	207969-0-00	13	208101-4-00	2/A
206400-4-00	5	206598-3-00	4	206695-0-00	5	207008-2-00	21	207878-3-00	7	207970-2-01	9	208111-4-00	2/B
206410-3-00	5	206599-0-01	4	206697-4-01	3	207015-2-00	22	207879-0-00	7	207971-0-00	9	208113-4-00	2/A
206415-4-00	5	206602-0-00	4	206699-0-02	3	207016-2-00	22	207880-0-00	7	207972-4-01	9	208133-2-00	7
206452-4-00	5	206603-0-10	4	206703-4-01	3	207017-2-00	22	207881-2-00	7	207973-0-01	9	208135-4-01	7
206453-4-00	5	206605-0-01	4	206705-4-01	3	207024-2-00	22	207882-2-00	7	207975-0-00	10	208142-3-01	6
206507-0-00	3	206606-2-00	4-6	206708-0-00	3	207027-0-00	18/B	207887-4-00	7	207976-0-00	13	208144-0-00	13
206508-0-00	3	206613-0-00	4	206711-0-00	2/A-2/B	207028-0-00	19/B	207893-0-00	2/A-2/B	207977-0-00	9	208148-4-00	13
206521-0-00	6	206615-4-00	4	206733-0-01	4	207077-0-00	18/B	207901-0-01	10	207978-0-00	9	208161-4-01	6
206533-0-00	6	206617-0-01	4	206734-2-00	1	207079-0-00	19/B	207909-0-00	10	207979-0-00	9	208163-4-11	6
206538-0-10	6	206618-0-10	4	206740-0-00	2/A-2/B	207095-2-00	5	207910-0-00	2/A	207980-0-00	1	208164-0-00	6
206539-0-01	8	206619-0-00	9	206747-0-01	2/A-2/B	207096-2-00	5	207911-0-00	2/B	207981-0-00	1	208165-0-00	1
206540-2-10	6	206620-0-00	7	206748-0-00	9	207100-3-01	20/D	207916-0-00	2/A-2/B	207983-0-00	1	208179-2-00	13
206543-0-01	3	206621-0-00	7	206754-0-00	2/A-2/B	207102-0-01	20/D	207917-0-00	9	207984-0-00	1	208184-2-00	2/A-2/B
206544-0-00	3	206622-0-00	7	206755-0-00	2/A-2/B	207111-0-00	8	207918-0-00	2/A-2/B	207985-0-00	1	208196-3-00	13
206545-0-00	10	206635-0-00	7	206756-0-01	1	207141-0-01	20/D	207919-0-00	2/A-2/B	207988-0-00	1	208204-2-00	13
206546-0-00	4	206637-0-00	7	206757-0-00	8	207143-0-01	20/D	207922-3-10	6	207990-0-00	6	208207-0-00	13
206550-4-03	9	206642-0-00	7	206758-0-00	8	207146-2-01	20/D	207927-0-01	6	207991-0-00	6	208208-0-00	13
206554-0-02	9	206643-0-01	5	206764-0-00	1	207147-3-01	20/D	207930-0-01	6	207992-0-00	6	208209-0-00	13
206555-0-02	9	206645-4-02	5	206767-0-00	1	207148-0-01	16/C	207932-0-10	6	207995-0-00	6	208219-3-00	13
206556-0-01	3	206650-0-00	2/A	206768-0-00	1	207417-0-00	8	207942-3-00	4	207998-2-00	6	208220-0-00	6
206557-0-00	9	206651-0-00	5	206769-0-10	1	207421-0-01	8	207943-2-00	4	207999-0-00	6	208221-0-00	6
206558-0-01	10	206652-2-01	5	206771-0-12	7	207510-4-00	6	207944-0-00	4	208010-0-00	9	208222-0-00	6

INDICE NUMERICO INDEX

Part N	Tav N	Part N	Tav N	Part N	Tav N	Part N	Tav N	Part N	Tav N	Part N	Tav N	Part N	Tav N
208310-4-00	13	704213-2-00	6-8	722410-2-00	2/B	741453-2-00	20/B-20/D	745815-2-00	4	920114-0-10	28	991153-2-00	29
208350-4-00	13	704216-2-00	27	722420-2-00	29	741546-2-00	4	746001-2-00	26	920128-0-00	28	991172-0-00	14
208364-0-00	20/D	704218-2-00	24/A	722431-2-00	14	741535-0-00	9	746003-0-00	29	920230-0-00	28	991174-0-00	14
208365-3-00	20/D	704314-2-00	4	722471-2-00	8	741552-0-00	6	746007-2-00	1-7-9-25	920231-0-00	28	991179-0-01	14
208367-0-00	20/D	704345-2-00	12	722480-2-00	6	741558-0-00	2/A-2/B	746008-0-00	4	920232-2-00	28	991187-0-01	12
208368-0-00	20/D	704346-2-00	12	722511-2-00	9	741634-2-00	13	746020-2-00	7	920235-0-00	28	991194-4-00	14
208520-2-10	6	704406-0-00	8	722905-2-00	12	741642-2-00	26	746021-2-00	27	920236-0-01	28	991199-0-00	14
208521-2-00	8	704424-2-00	12-27	723266-2-00	29	741657-0-00	2/A-2/B	746208-2-00	1	920241-0-01	28	991206-0-00	14
300218-0-10	2/A-2/B	704428-2-00	1	724032-0-00	4	741658-2-00	1-7	746402-2-00	12	920242-2-00	28	991218-0-00	10
300387-0-10	24/A	704536-0-00	10	724460-0-00	6	741665-2-00	20/A-20/B	746409-2-00	12	820245-4-02	28	991220-0-00	29
300483-0-10	26	704630-0-00	6	724895-2-00	4		20/C-20/D	765200-1-70	6	920490-0-10	28	991221-0-00	29
300710-0-10	25	704808-0-00	4	727014-2-00	6	741675-2-00	20/A-20/B	765200-1-80	6	920752-0-11	20/D	991222-0-00	29
301586-0-10	7-9	704813-0-00	9	727021-0-00	6		20/C-20/D-27	765200-1-90	6	925433-0-00	14	991223-0-00	29
301608-0-00	6	704829-0-00	4	727096-0-00	7	741685-2-00	20/B-20/C	778202-0-00	5	926273-0-00	7	991225-4-00	29
303322-0-00	24/A	704841-0-00	4	727884-0-00	4		20/D	778204-0-00	6-7	990176-0-10	11	991228-4-10	29
307137-0-00	1	704845-0-00	5	729012-2-00	6	741745-2-00	4	778206-0-00	6	990179-4-11	12	991229-2-00	29
309560-0-00	6	704847-0-00	5	729013-2-00	13-25-28-	741956-2-00	3-2/A-2/B	778208-0-00	6	990183-0-12	11	991247-2-00	14
310167-0-00	6	704848-0-00	5		26-27	742086-2-00	9	778236-0-00	5	990285-4-00	29	991263-2-00	29
311408-0-00	29	705008-0-00	4	729022-2-00	1-9	742457-2-00	8	778237-0-00	13	990310-0-10	12	991264-2-00	14
700205-0-00	12-27	705030-0-00	6-8	729024-2-00	29	742758-0-00	8	778241-0-00	9	990311-0-10	12	991268-0-00	14
700206-0-00	4-28	705208-0-00	4	729032-2-00	4	742811-0-00	24/B	778401-0-00	5	990314-0-10	12	991269-2-00	14
700207-0-00	4	705230-0-00	4	729034-2-00	6-14-29	742838-2-00	6	778403-0-00	5	990316-0-11	12	991279-2-00	14
700630-0-00	3	705408-0-00	4	729051-2-00	4-6-7	743243-2-00	5	778405-0-00	5	990325-0-10	11	991284-0-00	11
701002-0-00	9	705970-0-00	9	729054-2-00	29	743464-2-00	25	778410-0-00	5	990335-0-10	10	991321-2-00	29
701004-0-00	4-7-9	705975-0-00	9	730011-2-00	4	743469-2-00	6-8	778414-0-00	6	990452-0-00	12	991400-4-02	11
701005-0-00	10	705977-0-00	10	730023-2-00	1	744002-0-00	5	778417-0-00	4-6	990474-0-11	11	991415-0-00	11
701007-0-00	4	705982-0-00	9	731107-2-00	29	744332-2-00	4-7	778419-0-00	6	990592-2-11	29	991580-4-00	29
701031-0-00	9	711408-0-00	29	731506-2-00	14	744334-2-00	4-6-8	778503-0-00	6	990593-0-11	29	991581-2-00	29
701051-0-00	10	720411-2-00	10	733008-2-00	10-12-28	744409-2-00	8	778511-0-00	6	990594-2-00	29	991582-2-00	29
701106-0-00	9	720431-2-00	2/A-2/B-27	733211-2-00	14	744510-0-00	16/A-16/B	778522-0-00	7	990596-0-10	29	991589-4-00	29
701113-0-00	5	721412-2-00	1-24/B-24/C	733503-0-00	2/A-2/B-13		16/C-20/A	778832-0-00	6	990639-0-10	11	991590-2-00	29
701116-0-00	3	721413-2-00	24/D	733505-2-00	7-14	744512-4-00	24/B-4	778833-0-00	6	990685-0-10	11		
701133-0-00	3	721424-2-00	20/B	733507-2-00	9	744533-0-00	8-27	778835-0-00	8	990694-0-01	7		
702406-0-00	25	721434-2-00	20/C	733508-2-00	14	744553-0-00	8	778837-0-00	6-13	990723-0-00	11		
702408-0-00	25	721435-2-00	7-26-27	733806-2-00	14	744631-2-00	2/A-2/B	778842-0-00	13	990934-0-00	13		
702415-0-00	1	721443-2-00	1	740035-0-00	28	744730-2-00	9-25	788001-0-01	2/A-2/B	990981-0-00	12		
703003-0-00	29	721444-2-00	1-9-24/B-26	740041-2-00	13	744742-2-00	16/A-16/B	900201-0-10	12	990982-0-00	12		
703005-0-00	14	721445-2-00	24/A	740053-2-00	4		16/C	900203-0-10	12	990984-4-10	12		
703405-0-00	4	721454-2-00	1	741405-0-00	6	745002-0-00	2/A-6	900204-0-10	12	990987-4-00	12		
704104-2-00	2/B	721484-2-00	2/A-2/B-10	741413-2-00	4-20/A-20/B	745114-0-00	6-7	900694-0-11	12	991108-2-01	14		
		721494-2-00	9		20/C	745168-0-00	5	901101-0-00	12	991112-0-00	14		
		721883-0-00	5	741415-2-00	5-6	745800-2-00	1-2/A-2/B	901102-0-00	12	991114-2-00	29		
		722063-2-00	1-3-4-7-9-10	741431-2-00	20/A-20/B		5-13	920103-0-11	28	991120-5-01	14		
		722073-2-00	13		20/C-20/D	745810-2-00	5-6	920105-0-10	28	991126-0-10	14		
		722123-2-00	7	741453-0-00	7	745812-0-00	4-5-6-7	920113-0-10	28	991134-0-00	14		

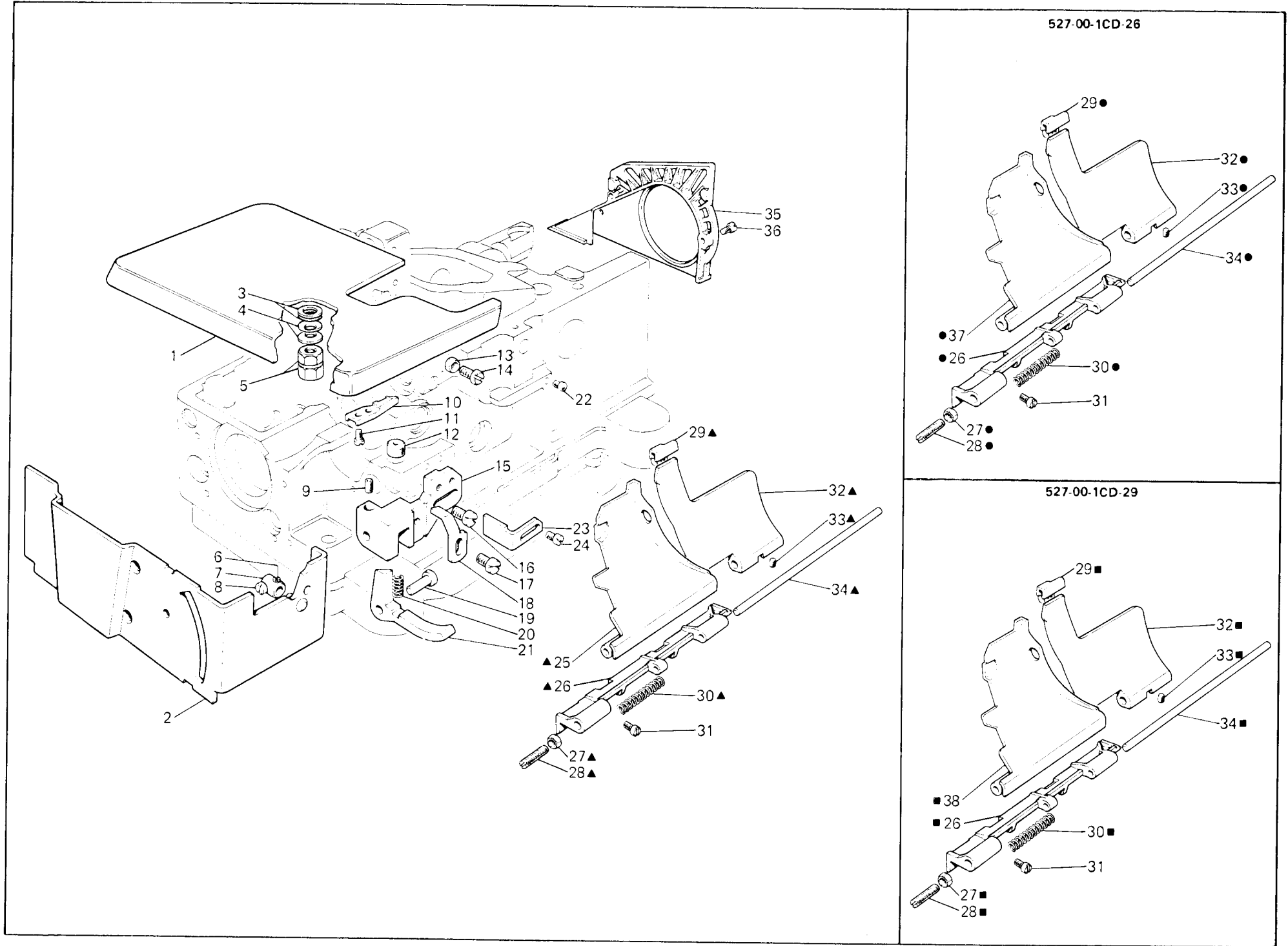

Fig. N Abb. N	Part N Piece N Bestell N Pieza N.	Qt Anzahl	DESCRIZIONE	DESCRIPTION	DESCRIPTION
▲	208060-4-00	1	sportello anteriore completo	front cover assembly	carter avant complet
●	208063-4-00	1	sportello anteriore completo	front cover assembly	carter avant complet
■	208065-4-00	1	sportello anteriore completo	front cover assembly	carter avant complet
	527-00-1CD-26				
	527-00-1CD-29				
1	207955-2-01	1	piano di lavoro	working plate	plan de travail
2	208022-2-00	1	carter laterale	side cover	carter latéral
3	704428-2-00	2	rondella	washer	rondelle
4	702415-0-00	2	molla a tazza	cup spring	ressort à tasse
5	208165-0-00	2	dado	nut	écrou
6	730023-2-00	1	vite	screw	vis
7	206734-2-00	1	morsetto con viti	clamp with screw	collier de serrage avec vis
8	721435-2-00	1	vite	screw	vis
9	729022-2-00	1	vite	screw	vis
10	207985-0-00	1	gancio	hook	crochet
11	721454-2-00	2	vite	screw	vis
12	207958-0-01	1	gommino	dumper	caoutchouc
13	746007-2-00	1	dado	nut	écrou
14	202214-0-11	1	vite	screw	vis
15	207981-0-00	1	supporto	support	support
16	741963-0-00	2	vite	screw	vis
17	741658-2-00	1	vite	screw	vis
18	207988-0-00	1	squadretta	bracket	équerre
19	207980-0-00	1	perno	pin	pivot
20	307137-0-00	1	molla	spring	ressort
21	207983-0-00	1	leva	lever	levier
22	207856-0-00	1	gommino	dumper	caoutchouc
23	207984-0-00	1	squadretta	bracket	équerre
24	721412-2-00	2	vite	screw	vis
25	208080-2-00	1	sportello scorrevole	sliding cover	couvercle coulissant
26	206756-0-01	1	cerniera	hinge	charnière
27	746208-2-00	1	dado	nut	écrou
28	206769-0-10	1	vite di regolazione	adjustment screw	vis de réglage
29	206764-0-00	1	zoccolo	block	socle
30	206768-0-00	1	molla	spring	ressort
31	721443-2-00	4	vite	screw	vis
32	207858-0-00	1	sportello ribaltabile	cover	couvercle
33	745800-2-00	1	vite	screw	vis
34	206767-0-00	1	perno	pin	pivot
35	206685-0-00	1	carter copringhia	cover	carter
36	722063-2-00	2	vite	screw	vis
37	208082-2-00	1	sportello scorrevole	cover	carter
38	208084-2-00	1	sportello scorrevole	cover	carter

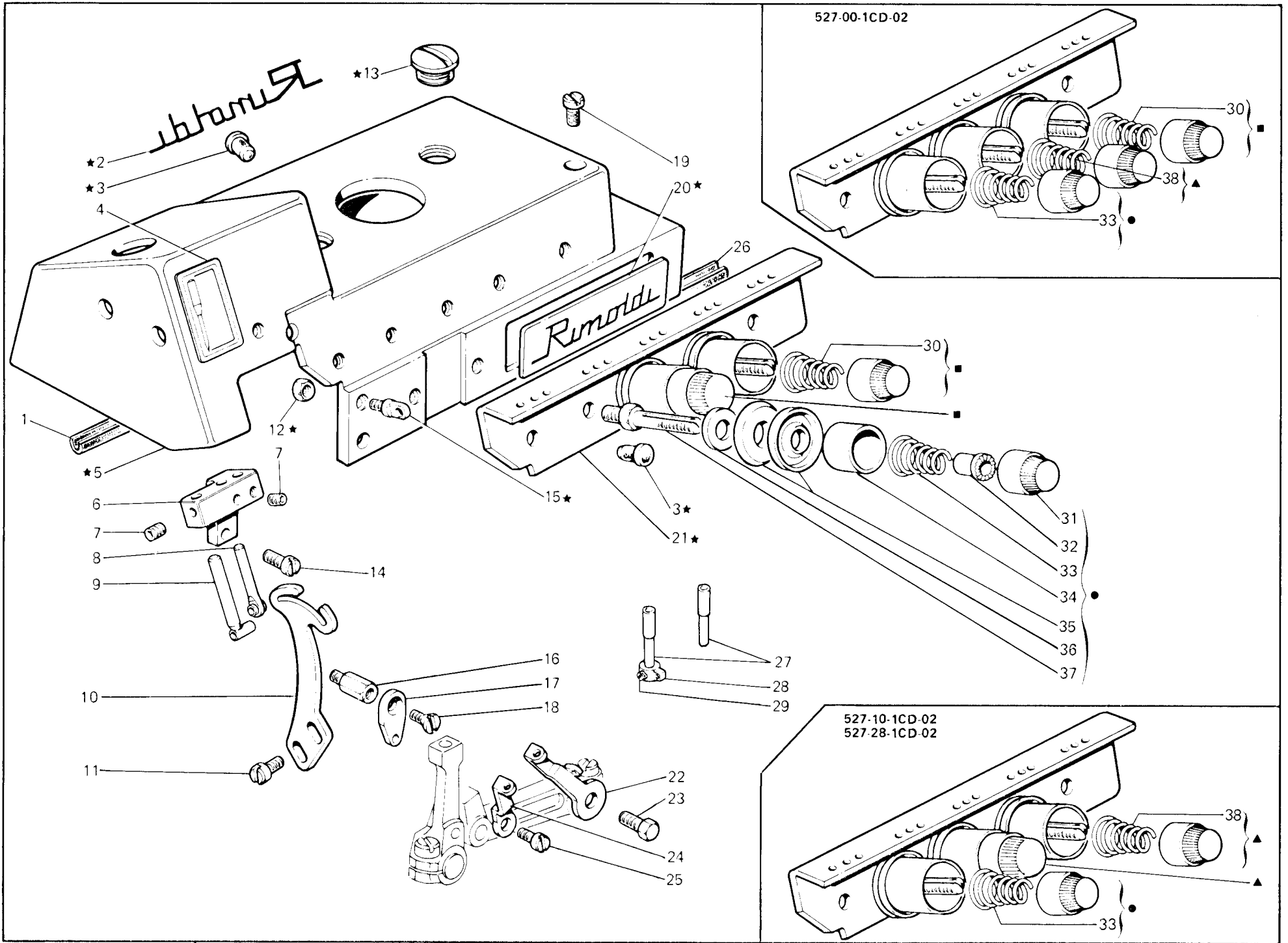

Fig. N Abb N	Part N Piece N Bestell N Pieza N	Qt Anzahl	DESCRIZIONE	DESCRIPTION	DESCRIPTION
★ ■ ●	208100-4-00	1	coperchio superiore completo	upper cover assembly	couvercle sup. complet
★ ■ ● ▲ ●	208101-4-00	1	coperchio superiore completo 527-00-1CD-02	upper cover assembly	couvercle sup. complet
★ ▲ ●	208113-4-00	1	coperchio superiore completo 527-10-1CD-02/527-28-1CD-02	upper cover assembly	couvercl- sup. complet
■	206341-4-00	1	tensione completa	tensione assembly	tension complète
●	206342-4-00	1	tensione completa	tension assembly	tension complète
▲	206343-4-00	1	tensione completa	tension assembly	tension complète
1	208091-0-01	1	guarnizione	gasket	garniture
2	100305-0-10	1	decalcomania	decal	décalcomanie
3	207893-0-00	4	tappo	plug	bouchon
4	788001-0-01	1	decalcomania sist. aghi	needle syst. decal	décalcomanie sist. aiguilles
5	207910-0-00	1	coperchio superiore	upper cover	couvercle sup.
6	207916-0-00	1	supporto pass. aghi	support	support
7	745800-2-00	2	vite	screw	vis
8	208184-2-00	1	passafilo completo	thread guide assembly	passe-fil complet
9	202267-2-13	1	passafilo ago	needle thread guide	passe-fil aiguille
10	207872-0-00	1	tendifilo ago	needle thread take-up	tendeur du fil aiguille
11	741558-0-00	2	vite	screw	vis
12	733503-0-00	2	dado	nut	écrou
13	207968-0-01	2	tappo	plug	bouchon
14	741956-2-00	2	vite	screw	vis
15	206711-0-00	3	passafilo	thread guide	passe-fil
16	206755-0-00	1	colonnina per passafilo	threaded tube	tube pour passe-fil
17	206812-0-00	1	passafilo crochet superiore	upper looper thread guide	passe-fil crochet sup.
18	744631-2-00	1	vite	screw	vis
19	721484-2-00	3	vite	screw	vis
20	207918-0-00	1	targhetta	plate	plaque
21	207919-0-00	1	piastra passafili	plate thread guide	plaque passe-fil
22	206650-0-00	1	tendifilo crochet inf.	thread take-up	tendeur du fil
23	720431-2-00	1	vite	screw	vis
24	202279-0-10	1	tendifilo	thread take-up	tendeur du fil
25	741657-0-00	1	vite	screw	vis
26	208090-0-01	1	guarnizione	gasket	garniture
27	206740-0-00	2	tubetto passafilo	pipe thread guide	tube passe-fil
28	203135-2-10	1	passafilo con vite	thread guide with screw	passe-fil avec vis
29	745002-0-00	1	vite	screw	vis
30	202227-0-10	2	molla \varnothing 0,8 mm.	spring \varnothing 0,8 mm.	ressort \varnothing 0,8 mm.
31	202558-2-01	3	pomolo	knob	pommeau
32	202229-0-10	3	bussola	bush	bague
33	202228-0-10	1	molla \varnothing 1 mm.	spring \varnothing 1 mm.	ressort \varnothing 1 mm.
34	202556-0-01	3	scodellino	cup	cuvette
35	300218-0-10	6	disco tensione	tension disc	disque tension
36	206754-0-00	3	rondella	washer	rondelle
37	206747-0-01	1	perno	pin	pivot
38	202681-0-10	1	molla \varnothing 0,6 mm.	spring \varnothing 0,6 mm.	ressort \varnothing 0,6 mm.

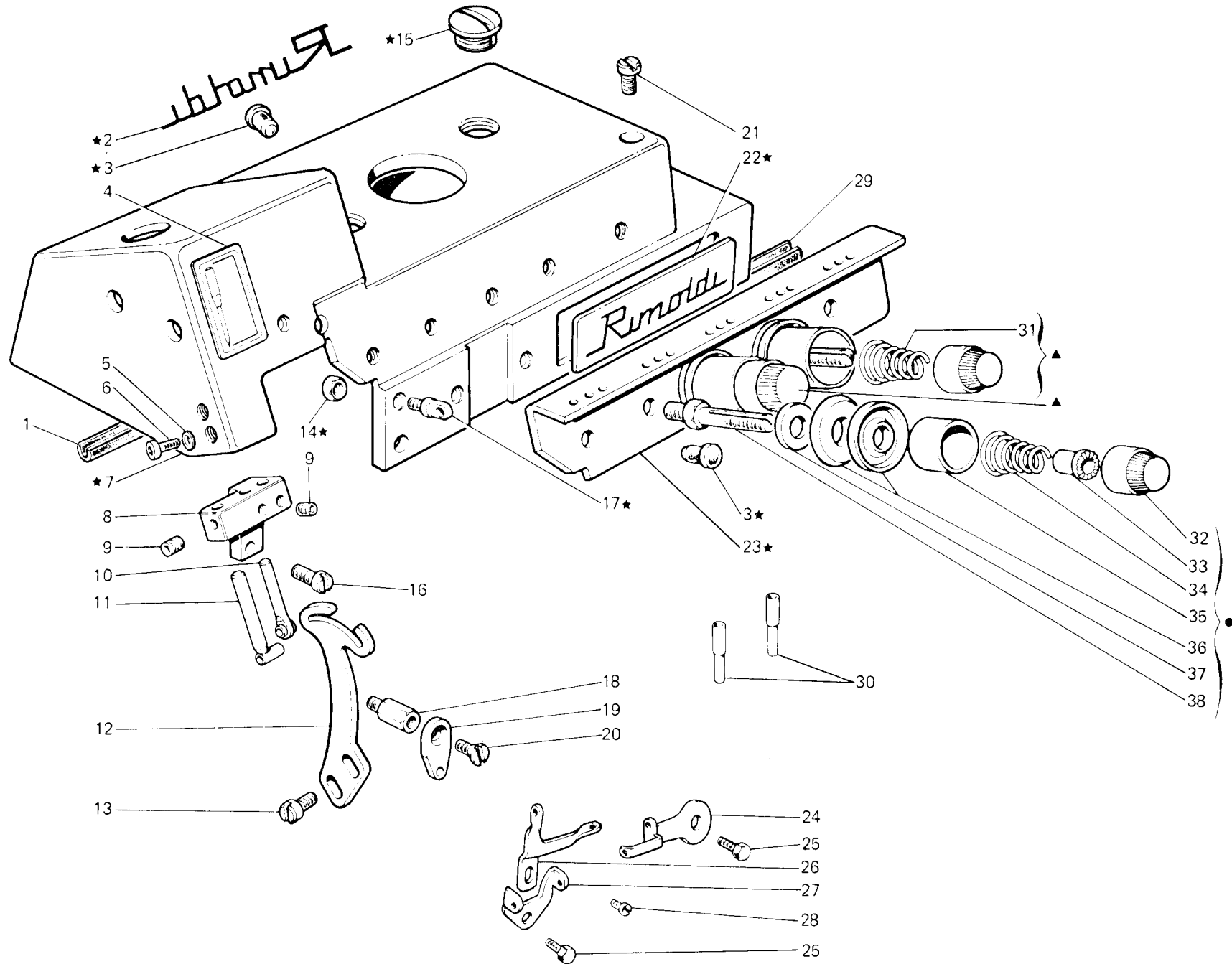

Fig. N. Abb. N.	Part. N. P.ice N. Bestell N. Pieza N.	Qt. Anzahl	DESCRIZIONE	DESCRIPTION	DESCRIPTION
★●▲	208111-4-00	1	coperchio superiore completo	upper cover assembly	couvercle sup. complet
●	206342-4-00	1	tensione completa	tension assembly	tension complète
▲	206343-4-00	1	tensione completa	tension assembly	tension complet
1	208091-0-00	1	guarnizione	gasket	garniture
2	100305-0-10	1	decalcomania	decal	decalcomanie
3	207893-0-00	4	tappo	plug	bouchon
4	788001-0-01	1	decalcomania sist. aghi	needle syst. decal	decalcomanie syst. aiguilles
5	704104-2-00	2	rosetta	washer	rondelle
6	722410-2-00	2	vite	screw	vis
7	207911-0-00	1	coperchio superiore	upper cover	couvercle sup.
8	207916-0-00	1	supporto passafili aghi	support	support
9	745800-2-00	2	vite	screw	vis
10	208184-2-00	1	passafilo completo	thread guide assembly	passe-fil complet
11	202267-2-13	1	passafilo ago	needle thread guide	passe-fil aiguilles
12	207871-0-00	1	tendifilo ago	needle thread take-up	tendeur du fil aiguille
13	741558-0-00	2	vite	screw	vis
14	733503-0-00	3	dado	nut	écrou
15	207968-0-01	2	tappo	plug	bouchon
16	741956-2-00	2	vite	screw	vis
17	206711-0-00	3	passafilo	thread guide	passe-fil
18	206755-0-00	1	colonnina per passafilo	threaded tube	tube pour passe-fil
19	206812-0-00	1	passafilo crochet superiore	upper looper thread guide	passe-fil crochet sup
20	744631-2-00	1	vite	screw	vis
21	721484-2-00	3	vite fissa coperchio sup.	screw	vis
22	207918-0-00	1	targhetta	plate	plaque
23	207919-0-00	1	piastra passafili	plate	plaque
24	202283-0-10	1	tendifilo crochet inferiore	thread take-up	tendeur du fil
25	720431-2-00	2	vite	screw	vis
26	202280-0-10	1	tendifilo crochet superiore	upper looper thread take-up	tendeur du fil crochet sup.
27	741657-0-00	1	vite	screw	vis
28	202278-0-10	1	tendifilo ago	needle thread take-up	tendeur du fil aiguille
29	208090-0-00	1	guarnizione	gasket	garniture
30	206740-0-00	2	tubetto passafilo	pipe thread guide	tube passe-fil
31	202681-0-10	2	molla \varnothing 0,6 mm.	spring \varnothing 0,6 mm.	ressort \varnothing 0,6 mm.
32	202558-2-01	3	pomolo	knob	pommeau
33	202229-0-10	3	bussola	bush	bague
34	202228-0-10	1	molla \varnothing 1 mm.	spring \varnothing 1 mm.	ressort \varnothing 1 mm.
35	202556-0-01	3	scodellino	cup	cuvette
36	300218-0-10	6	disco tensione	tension disc	disque tension
37	206754-0-00	3	rondella	washer	rondelle
38	206747-0-01	3	perno	pin	pivot

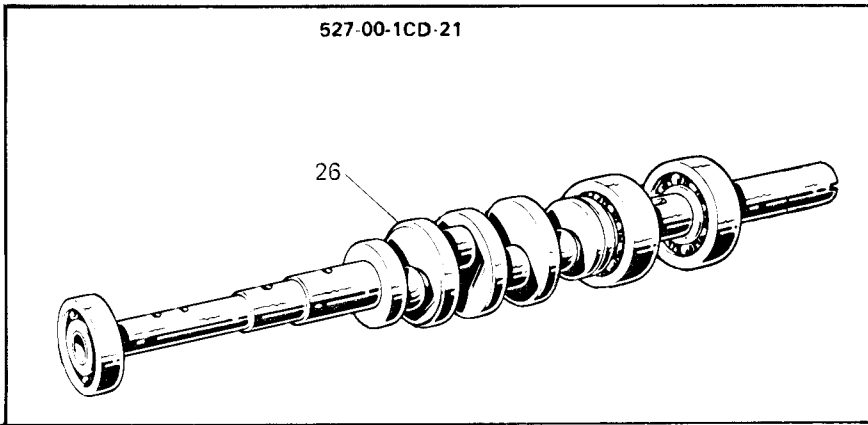
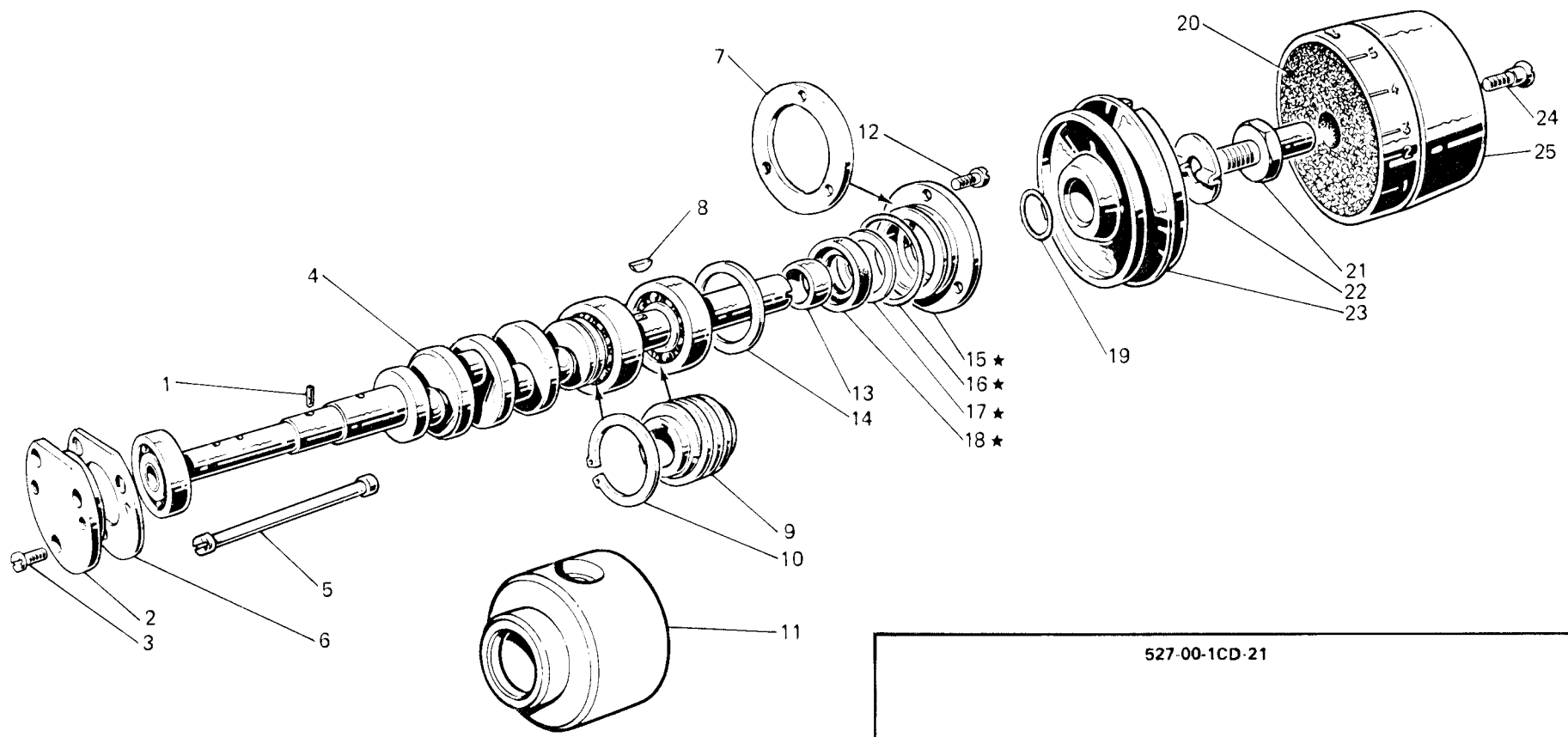
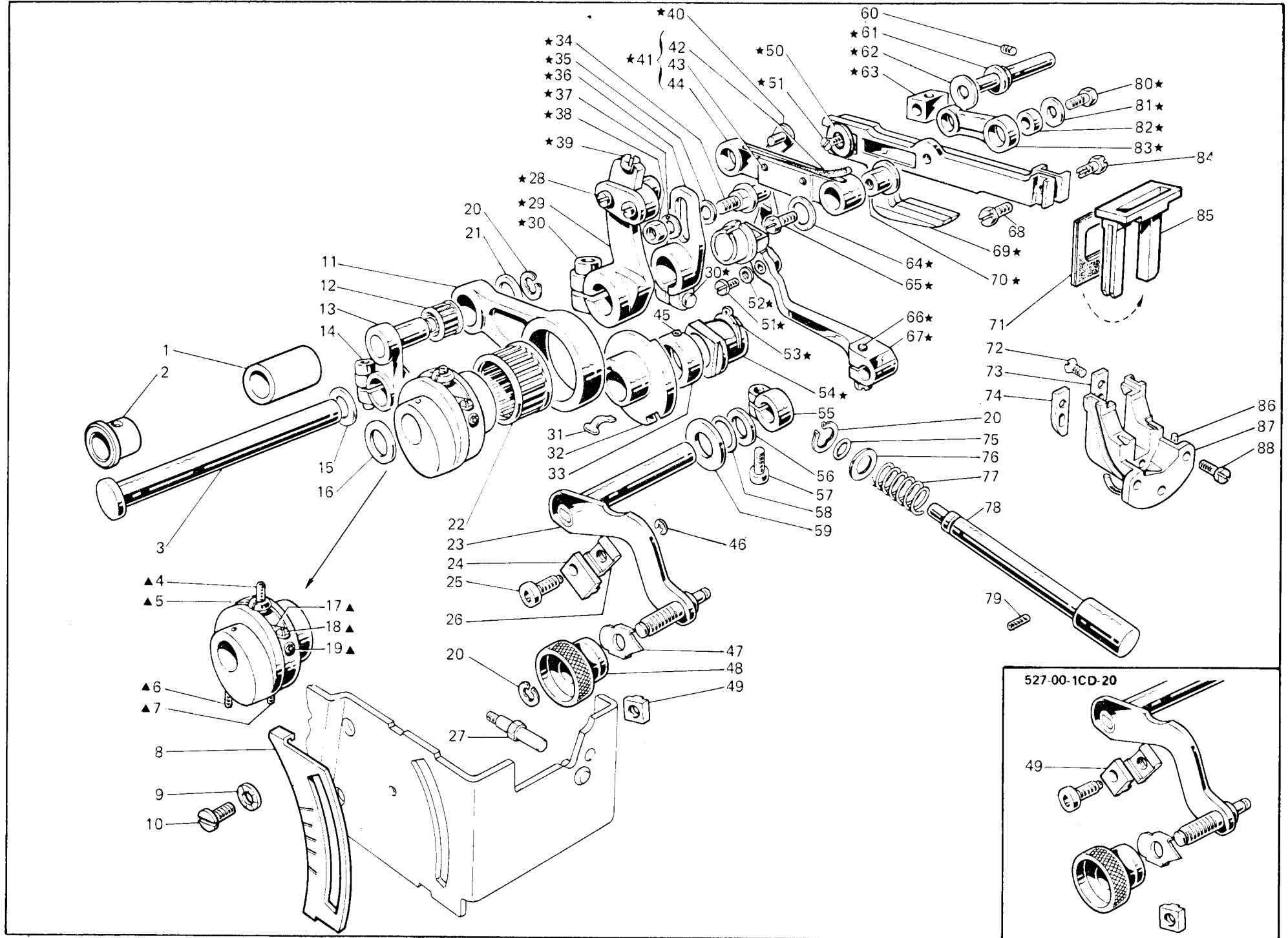
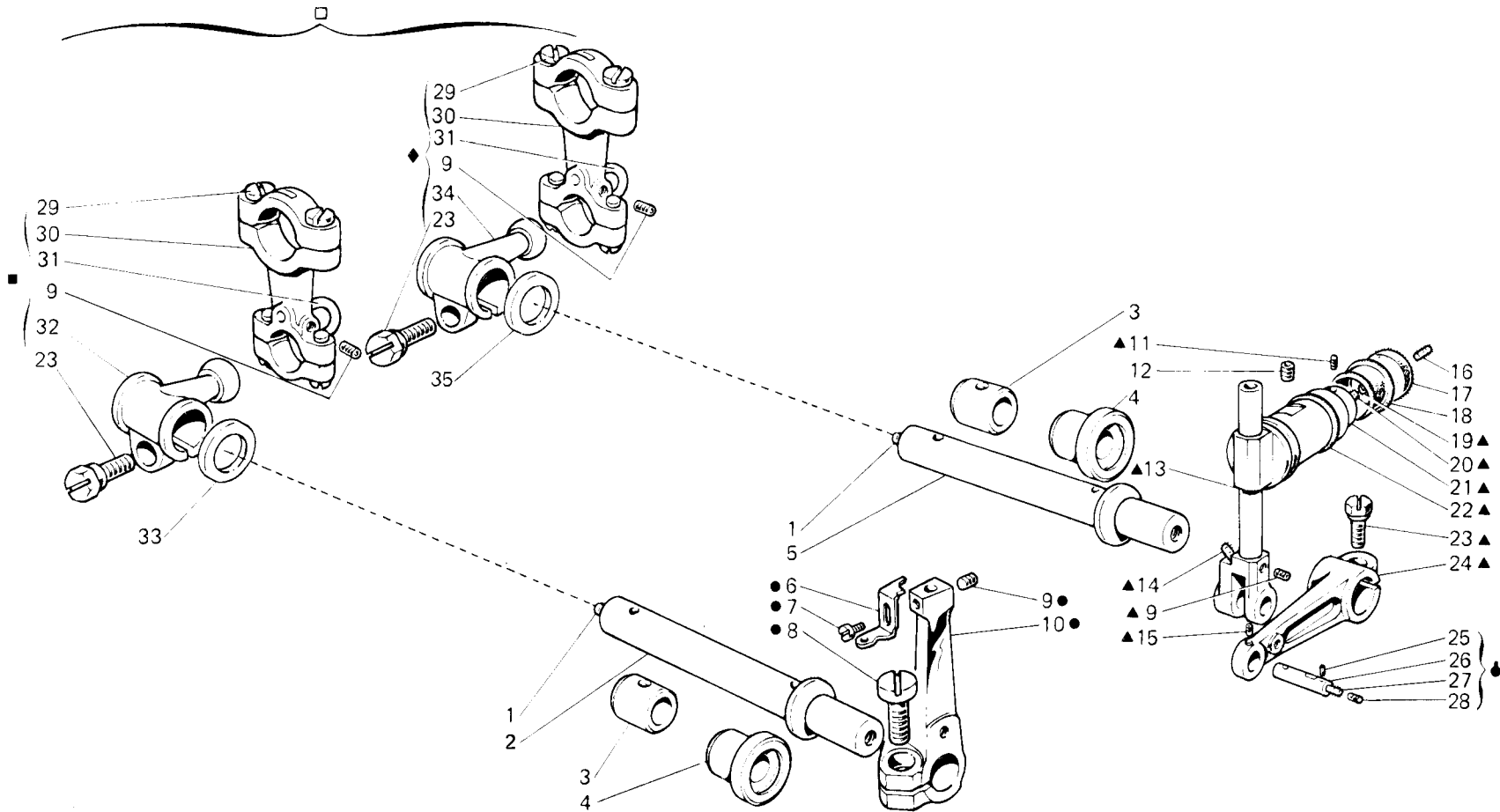

Fig. N. Abb. N.	Part. N. Bestell N. Piese N. Pieza N.	Qt. Anzahl	DESCRIZIONE	DESCRIPTION	DESCRIPTION
★	206697-4-01	1	gruppo flangia con anelli	flange with ring assembly	groupe flasque avec anneau
1	206708-0-00	1	stoppino	wick	mèche
2	206680-0-01	1	flangia sinistra	left flange	flasque gauche
3	741956-2-00	3	vite	screw	vis
4	206705-4-01	1	albero principale	main shaft	arbre principal
5	206974-0-00	1	limitatore olio	oil limiter	limiteur huile
6	206543-0-01	1	guarnizione	gasket	garniture
7	206544-0-00	1	guarnizione	gasket	garniture
8	204122-0-10	1	chiavetta	key	clavette
9	206556-0-01	1	vite senza fine	worm screw	vis sans fin
10	202386-0-10	1	anello elastico	spring ring	anneau ressort
11	206682-0-01	1	bussola	bush	bague
12	722063-2-00	3	vite	screw	vis
13	206692-0-00	1	distanziale albero principale	spacer	entretoise
14	206689-0-01	1	anello compensazione	ring	anneau
15	206699-0-02	1	flangia	flange	flasque
16	701133-0-00	1	anello di tenuta	retainer ring	bague d'étanchéité
17	206693-0-00	1	rondella	washer	rondelle
18	700630-0-00	1	anello di tenuta	retainer ring	bague d'étanchéité
19	701116-0-00	1	anello di tenuta	retainer ring	bague d'étanchéité
20	206507-0-00	1	tampone per volante	pad	tampon
21	206683-0-00	1	perno volante	pin	pivot
22	206684-0-00	1	chiavetta albero principale	key	clavette
23	206508-0-00	1	volantino	handwheel	volant
24	202492-0-10	1	vite	screw	vis
25	206679-0-00	1	coperchio volante	handwheel cover	couvercle volant
26	206703-4-01	1	albero princ. con cuscinetti	main shaft	arbre principal



N Fig. Abb.	Part. Bestell. Piece N. N.	Qt. Anzahl	DESCRIZIONE	DESCRIPTION	DESCRIPTION	N Fig. Abb.	Part. Bestell. Piece N. N.	Qt. Anzahl	DESCRIZIONE	DESCRIPTION	DESCRIPTION
★	208097-4-00	1	gruppo comando slitta	slide control assembly	groupe comm. glissière	49	206794-0-00	1	arresto reg. esterno	external retainer	butée réglable externe
▲	207950-4-00	1	gruppo ecc. reg. trasp.	eccentric assembly	groupe excentrique	50	202475-0-10	1	rondella	washer	rondelle
1	206594-0-00	1	bussola	bush	bague	51	724032-0-00	2	vite	screw	vis
2	206595-0-01	1	bussola	bush	bague	52	207719-0-00	1	rondella	washer	rondelle
3	206593-0-00	1	contrabero trasp.	trans.coutershaft	axe transport	53	201610-0-01	1	anello elastico	spring ring	anneau ressort
4	729051-2-00	1	vite	screw	vis	54	206617-0-01	1	blocchetto	block	bloc
5	206603-0-10	1	fermo eccentrico	eccentric retainer	pièce bloc. excentrique	55	100620-2-10	1	morsetto con vite	clamp with screw	collier de serr. avec vis
6	745815-2-00	1	vite	screw	vis	56	704829-0-00	1	rondella	washer	rondelle
7	727884-0-00	1	vite	screw	vis	57	741745-2-00	1	vite	screw	vis
8	206797-0-00	1	piastrina per indice	plate	plaque	58	701007-0-00	1	anello di tenuta	retainer ring	bague d'étanchéité
9	703405-0-00	4	rondella elastica	spring washer	rondelle élastique	59	705230-0-00	1	rondella	washer	rondelle
10	724895-2-00	4	vite	screw	vis	60	202478-0-10	1	vite	screw	vis
11	206599-0-01	1	biella com. trasp.	transport con-rod	bielle comm. transport	61	206613-0-00	1	perno eccentrico	eccentric pin	pivot excentrique
12	201358-0-10	1	gabbia a rullini	needles cage	cage à aiguilles	62	705408-0-00	1	rondella	washer	rondelle
13	206598-3-00	1	braccio a man. con vite	crank arm with screw	bras à maniv. avec vis	63	202033-0-10	1	blocchetto	block	bloc
14	744334-2-00	1	vite	screw	vis	64	705008-0-00	1	rondella	washer	rondelle
15	704841-0-00	1	rondella	washer	rondelle	65	206588-0-00	1	vite	screw	vis
16	206602-0-00	1	rondella	washer	rondelle	66	740053-2-00	1	vite	screw	vis
17	202412-0-11	1	lardone	gib	lardon	67	207711-2-10	1	braccio reg. diff.	differential arm	bras reg. différentiel
18	202473-0-11	2	vite	screw	vis	68	202489-0-10	1	vite	screw	vis
19	730011-2-00	2	vite	screw	vis	69	207942-3-00	1	gruppo slitta	slide assembly	groupe glissière
20	700207-0-00	3	anello elastico	spring ring	anneau ressort	70	206586-0-01	1	bussola per biellino	bush	bague
21	206546-0-00	1	rondella	washer	rondelle	71	207944-0-00	2	guarn.raschia olio	gasket	garniture
22	202385-0-10	1	gabbia a rullini	needles cage	cage à aiguilles	72	744512-4-00	2	vite	screw	vis
23	206790-2-11	1	leva	lever	levier	73	207947-0-00	1	piastrina	plate	plaque
24	206799-0-00	1	arresto reg. esterno	stopping	butée	74	207945-0-00	1	piastrina	plate	plaque
25	206875-0-00	2	vite	screw	vis	75	701004-0-00	1	anello	ring	anneau
26	206795-0-00	2	arresto reg. interno	stopping	butée	76	704314-2-00	1	rondella	washer	rondelle
27	206733-0-01	1	vite fissa carter lat.	screw	vis	77	202408-0-10	1	molla	spring	ressort
28	741546-2-00	2	vite	screw	vis	78	206618-0-10	1	pulsante reg. punto	push-button	poussoir
29	206592-3-00	1	manovella tras. con viti	tran. crank with screw	manivelle trans. avec vis	79	729032-2-00	1	vite	screw	vis
30	744332-2-00	2	vite	screw	vis	80	202490-0-10	1	vite	screw	vis
31	206872-0-00	1	molla	spring	ressort	81	705208-0-00	1	rondella	washer	rondelle
32	206605-0-01	1	eccentrico	eccentric	excentrique	82	202032-0-11	1	bussolina	bush	bague
33	206606-2-00	1	anello di rasamento	shim	bague	83	206583-0-00	1	biellino	con-rod	petite bielle
34	202063-0-10	1	spina	pin	goupille	84	202488-0-10	1	vite	screw	vis
35	704808-0-00	1	rondella	washer	rondelle	85	207946-0-01	1	telaio raschia olio	oil scraper frame	râcheur huile
36	206584-2-00	1	braccio manovella	crank arm	bras manivelle	86	207948-0-00	1	guarnizione	gasket	garniture
37	206580-2-00	1	rondella con spina	washer with pin	rondelle avec goupille	87	207943-2-00	1	guida slitta	slide guide	guide coulissant
38	746008-0-00	1	dado	nut	écrou	88	722063-2-00	3	vite	screw	vis
39	741413-2-00	1	vite	screw	vis						
40	207724-2-00	1	giunto	joint	joint						
41	206615-4-00	1	biellino completo	con-rod assembly	petite-bielle complète						
42	778417-0-00	1	stoppino	wick	mèche						
43	200490-0-00	2	spillo	needle	épingle						
44	206587-0-01	1	biellino	con-rod	petite-bielle						
45	745812-2-00	2	vite	screw	vis						
46	700206-0-00	2	anello elastico	spring ring	anneau ressort						
47	206796-0-00	1	indice	index	indice						
48	206798-0-00	1	bottono	button	bouton						



527-00-1CD-21

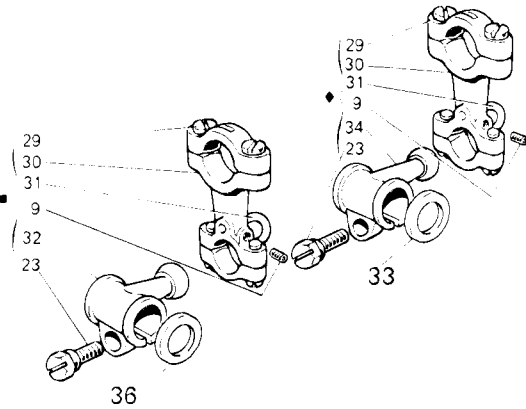

527-30-1CD-07

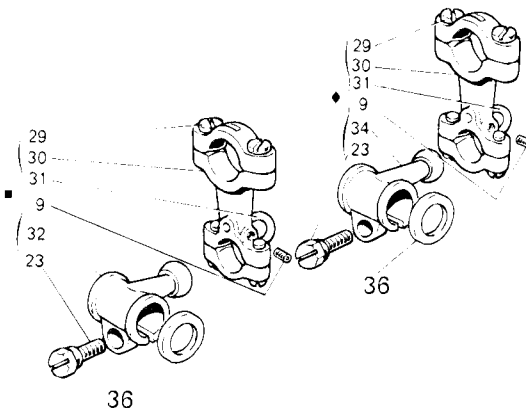

Fig. N. Abb. N.	Part. N. Piecce N. Bestell N. Pieza N.	Qt. Anzahl	DESCRIZIONE	DESCRIPTION	DESCRIPTION
□	206400-4-00	1	gruppo com. crochet sup. e inf.	control loopers assembly	groupe comm. crochets
★	206386-4-00	1	gruppo com. crochet sup. e inf.	control loopers assembly	groupe comm. crochets
△	206387-4-00	1	gruppo com. crochet sup. e inf. 527-00-1CD-21	control loopers assembly	groupe comm. crochets
■	206453-4-00	1	gruppo manicotto con biella	coupling ass. with con-rod	groupe manchon avec bielle
◆	206452-4-00	1	gruppo manicotto con biella	coupling ass. with con rod	groupe manchon avec bielle
▲	206415-4-00	1	gruppo comando crochet sup.	upper looper control ass.	groupe com. crochet sup.
●	206645-4-02	1	spina completa	pin assembly	goupille compl.
●	208039-4-00	1	gruppo porta crochet inf.	lower looper ass.	groupe porte crochet inf.
1	206695-0-00	2	tappo per albero	plug with shaft	bouchoun pour arbre
2	207096-2-00	1	albero crochet inferiore	lower looper shaft	arbre crochet inférieur
3	206651-0-00	2	bussola	bush	bague
4	202065-0-20	2	bussola	bush	bague
5	207095-2-00	1	albero crochet superiore	upper looper shaft	arbre crochet supérieur
6	208015-0-00	1	squadretta	braket	équerre
7	741415-0-00	1	vite	screw	vis
8	721883-0-00	1	vite	screw	vis
9	745812-2-00	4	vite	screw	vis
10	206654-2-10	1	porta crochet inf.	lower looper holder	porte crochet inférieur
11	745800-2-00	1	vite	screw	vis
12	745168-0-00	1	vite	screw	vis
13	206410-3-00	1	guida oscillante e porta crochet	oscillating guide and looper holder	guide oscillant et porte-crochet
14	778403-0-00	1	stoppino	wick	mèche
15	745810-2-00	1	vite	screw	vis
16	778236-0-00	1	stoppino	wick	mèche
17	206686-0-00	1	disco lubrificazione guida	lubrication disc	disque graissage
18	202720-0-00	1	paraolio	oil retainer	pare-huile
19	778405-0-00	1	stoppino	wick	mèche
20	778410-0-00	1	stoppino	wick	mèche
21	202062-2-10	1	anello con vite	ring with screw	anneau avec vis
22	701113-0-00	1	anello di tenuta	retainer ring	anneau d'étanchéité
23	201128-0-10	3	vite	screw	vis
24	206652-2-01	1	braccio	arm	bras
25	778202-0-00	4	stoppino	wick	mèche
26	202086-0-12	1	spina	pin	goupille
27	778401-0-00	1	stoppino	wick	mèche
28	745002-0-00	1	vite	screw	vis
29	743243-2-00	8	vite per biella	screw	vis
30	202071-2-20	2	biella con viti	con-rod with screw	bielle avec vis
31	206643-0-01	2	cavallotto	coupling	cavalier
32	206659-2-01	1	manicotto	coupling	manchon
33	704845-0-00	1	rondella 4,5 mm.	washer 4,5 mm.	rondelle 4,5 mm
34	206658-2-02	1	manicotto	coupling	manchon
35	704848-0-00	1	rondella 2 mm.	washer 2 mm.	rondelle 2 mm.
36	704847-0-00	1	rondella 5,9 mm.	washer 5,9 mm.	rondelle 5,9 mm.

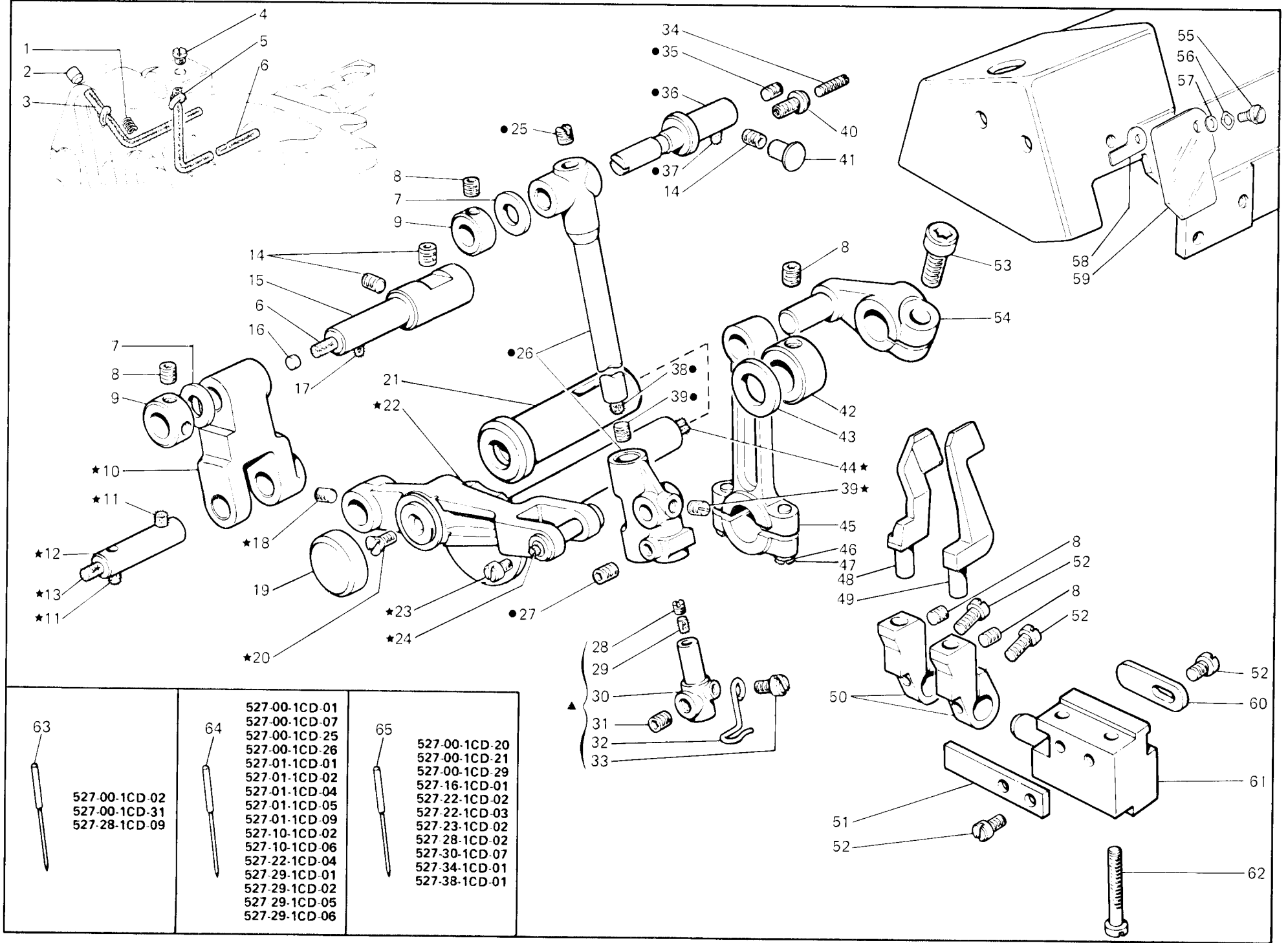

Fig. N. Abb. N.	Part. N. Bestell N. Piece N. Pieza N.	Qt. Anzahl	DESCRIZIONE	DESCRIPTION	DESCRIPTION	Fig. N. Abb. N.	Part. N. Bestell N. Piece N. Pieza N.	Qt. Anzahl	DESCRIZIONE	DESCRIPTION	DESCRIPTION
★ ●	208140-4-11	1	cinematismo com. ago	needle control ass.	cinématisme com. aiguille	47	743469-2-00	2	vite	screw	vis
●	208161-4-01	1	slitta con barra compl.	slide with bar ass.	glissière avec barre compl.	48	207992-0-00	1	salva ago	rear needle guard	protège-aiguille
▲	207510-4-00	1	morsetto ago compl.	needle clamp ass.	collier de serrage compl.	49	207995-0-00	1	spingi asola	front needle guard	pare-boucle
1	208164-0-00	1	molla	spring	ressort	50	207998-2-00	2	porta salva ago e spingi asola	front and rear needle guard holder	porte protège-aiguille et pare-boucle
2	301608-0-00	1	tappo	plug	bouchon						
3	778832-0-00	1	stoppino	wick	mèche	51	207991-0-00	1	piastrina	plate	plaque
4	742838-2-00	1	vite	screw	vis	52	741552-0-00	5	vite	screw	vis
5	778833-0-00	1	stoppino	wick	mèche	53	744334-2-00	1	vite	screw	vis
6	778417-0-00	2	stoppino	wick	mèche	54	206540-2-10	1	manovella aib. sup.	crank	manivelle
7	309560-0-00	2	rondella	washer	rondelle	55	208224-0-00	1	vite	screw	vis
8	745812-0-00	7	vite	screw	vis	56	208220-0-00	1	anello elastico	spring ring	anneau ressort
9	207692-2-00	2	anello di rasamento	ring	anneau	57	704630-0-00	1	rondella	washer	rondelle
10	207932-0-10	1	leva	lever	levier	58	208222-0-00	1	piastrina	plate	plaque
11	778204-0-00	3	stoppino	wick	mèche	59	208221-0-00	1	piastrina protezione	protection plate	plaque protection
12	207930-0-10	1	spina	pin	goupille	60	207999-0-00	1	piastrina	plate	plaque
13	778414-0-00	1	stoppino	wick	mèche	61	207990-0-00	1	supporto salva ago	rear needle guard ass.	supporto protège-aiguille
14	729034-2-00	3	vite	screw	vis	62	722480-2-00	2	vite	screw	vis
15	208163-4-11	1	perno completo	pin assembly	pivot complet	63	765200-1-70		ago RIM 27 fin. 70	needle RIM 27 size 70	aiguille RIM 27 jauge 70
16	206521-0-00	1	tappo	plug	bouchon	64	765200-1-80		ago RIM 27 fin. 80	needle RIM 27 size 80	aiguille RIM 27 jauge 80
17	778511-0-00	2	stoppino	wick	mèche	65	765200-1-90		ago RIM 27 fin. 90	needle RIM 27 size 90	aiguille RIM 27 jauge 90
18	745114-0-00	1	vite	screw	vis						
19	206533-0-00	1	coperchio per leva	cover for lever	couvercle pour levier						
20	724460-0-00	1	vite	screw	vis						
21	206538-0-10	1	bussola	bush	bague						
22	208142-3-01	1	gruppo leva con spina	lever with pin ass.	groupe levier avec goupille						
23	741405-0-00	1	vite	screw	vis						
24	778208-0-00	1	stoppino	wick	mèche						
25	310167-0-00	1	vite	screw	vis						
26	207922-3-10	1	slitta con barra	slide with bar	glissière avec barre						
27	729012-2-00	1	vite	screw	vis						
28	727021-0-00	1	vite	screw	vis						
29	778206-0-00	1	stoppino	wick	mèche						
30	207520-2-00	1	morsetto	clamp	collier de serrage						
31	745810-2-00	1	vite	screw	vis						
32	207540-0-00	1	guidafilo	thread guide	guide fil						
33	741415-2-00	1	vite	screw	vis						
34	729051-2-00	1	vite	screw	vis						
35	727014-2-00	1	vite	screw	vis						
36	207927-0-01	1	perno	pin	pivot						
37	778419-0-00	1	stoppino	wick	mèche						
38	778503-0-00	1	stoppino	wick	mèche						
39	745002-0-00	2	vite	screw	vis						
40	202529-0-10	1	vite di fermo	screw	vis						
41	207574-0-00	1	tappo	plug	bouchon						
42	206606-2-00	1	anello di rasamento	ring	anneau						
43	705030-0-00	1	rondella	washer	rondelle						
44	778837-0-00	1	stoppino	wick	mèche						
45	208520-2-10	1	biella completa	con-rod assembly	bielle compl.						
46	704213-2-00	2	rondella	washer	rondelle						

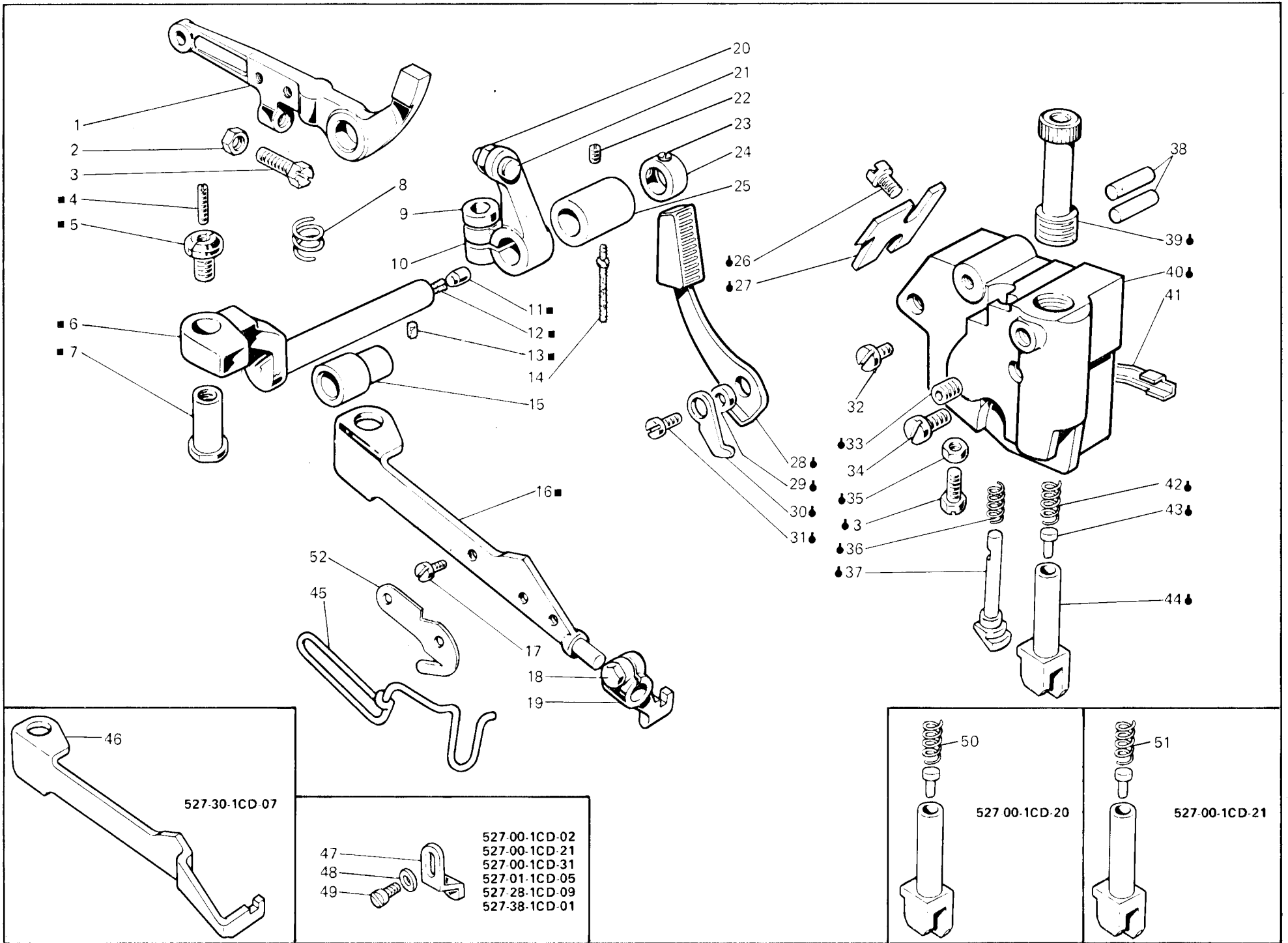

Fig. N. Abb. N.	Part. N. Bestell N. Pieze N. Pieza N.	Qt. Anzahl	DESCRIZIONE	DESCRIPTION	DESCRIPTION	Fig. N. Abb. N.	Part. N. Bestell N. Pieze N. Pieza N.	Qt. Anzahl	DESCRIZIONE	DESCRIPTION	DESCRIPTION
●	208135-4-01	1	gruppo supp. premist.	presser support ass.	groupe supp. pied-press.	43	207626-0-00	1	bottono	buton	bouton
■	207887-4-00	1	leva prem. con perno	presser lever	levier du pied-presséur	44	207625-0-00	1	cannotto	column	fourche
1	207881-2-00	1	leva alza premist.	lever	levier	45	990694-0-01	1	salvadita	protection	protection
2	733505-2-00	1	dado	nut	écrou	46	206845-0-01	1	leva	lever	levier
3	202214-0-11	2	vite	screw	vis	47	206771-0-12	1	squadretta fermo pied.	bracket	équerre
4	729051-2-00	1	vite	screw	vis	48	704004-0-00	1	rondella	washer	rondelle
5	202529-0-10	1	perno di fermo	pin	pivot	49	741658-2-00	1	vite	screw	vis
6	207878-3-00	1	perno con tappo e stoppini	pin with plung and wicks	pivot avec bouchon et mèches	50	202118-0-10	1	molla	spring	ressort
7	206622-0-00	1	spina	pin	pivot	51	205021-0-10	1	molla	spring	ressort
8	206621-0-00	1	molla richiamo leva premist.	spring	ressort				SOLO A RICHIESTA	ONLY ON REQUEST	SEULEMENT SUR DEMANDE
9	744332-2-00	1	vite	screw	vis						
10	207876-2-00	1	leva arresto prest. con viti	lever	levier	52	202194-0-11	1	piastrina tagliacat. 527-00-1CD-01/527-00-1CD-20	plate	plaque
11	301586-0-10	1	pastiglia	plug	bouchon						
12	778522-0-00	1	stoppino	wick	mèche						
13	778204-0-00	1	stoppino	wick	mèche						
14	206620-0-00	1	stoppino	wick	mèche						
15	207880-0-00	1	bussola	bush	bague						
16	206808-0-01	1	leva	lever	levier						
17	741453-0-00	2	vite	screw	vis						
18	204947-0-10	1	vite	screw	vis						
19	206810-2-00	1	attacco a morsetto premist.	coupling	raccord						
20	746020-2-00	1	dado	nut	écrou						
21	727096-0-00	1	vite	screw	vis						
22	745812-2-00	1	vite	screw	vis						
23	745114-0-00	2	vite	screw	vis						
24	207882-2-00	1	anello con viti	ring	anneau						
25	207879-0-00	1	bussola	bush	bague						
26	721434-2-00	2	vite	screw	vis						
27	207965-0-00	1	arresto	stopping	butée						
28	208133-2-00	1	leva	lever	levier						
29	206637-0-00	1	distanziale	spacer	entretoise						
30	206635-0-00	1	nasello	snug	décllic						
31	722063-2-00	1	vite	screw	vis						
32	722123-2-00	1	vite	screw	vis						
33	202391-0-11	1	vite	screw	vis						
34	206642-0-00	1	vite	screw	vis						
35	746007-2-00	1	dado	nut	écrou						
36	926273-0-00	1	molla	spring	ressort						
37	207959-0-00	1	tirante	tie-rod	tirant						
38	202371-0-10	2	spina	pin	goupille						
39	207967-0-01	1	vite	screw	vis						
40	207960-0-00	1	supporto	support	support						
41	207962-0-00	1	guarnizione	gasket	garniture						
42	203142-0-10	1	molla	spring	ressort						

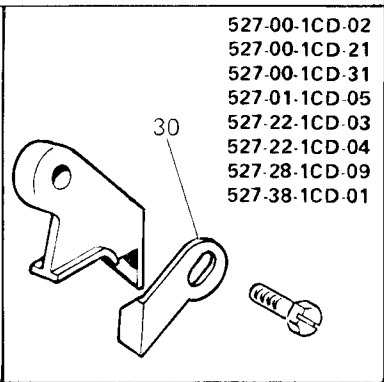
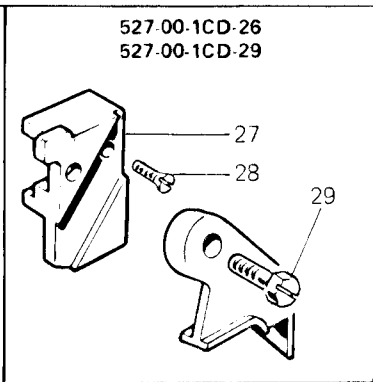
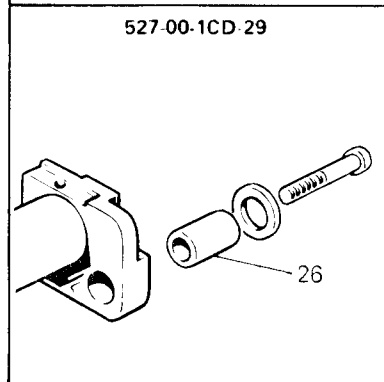
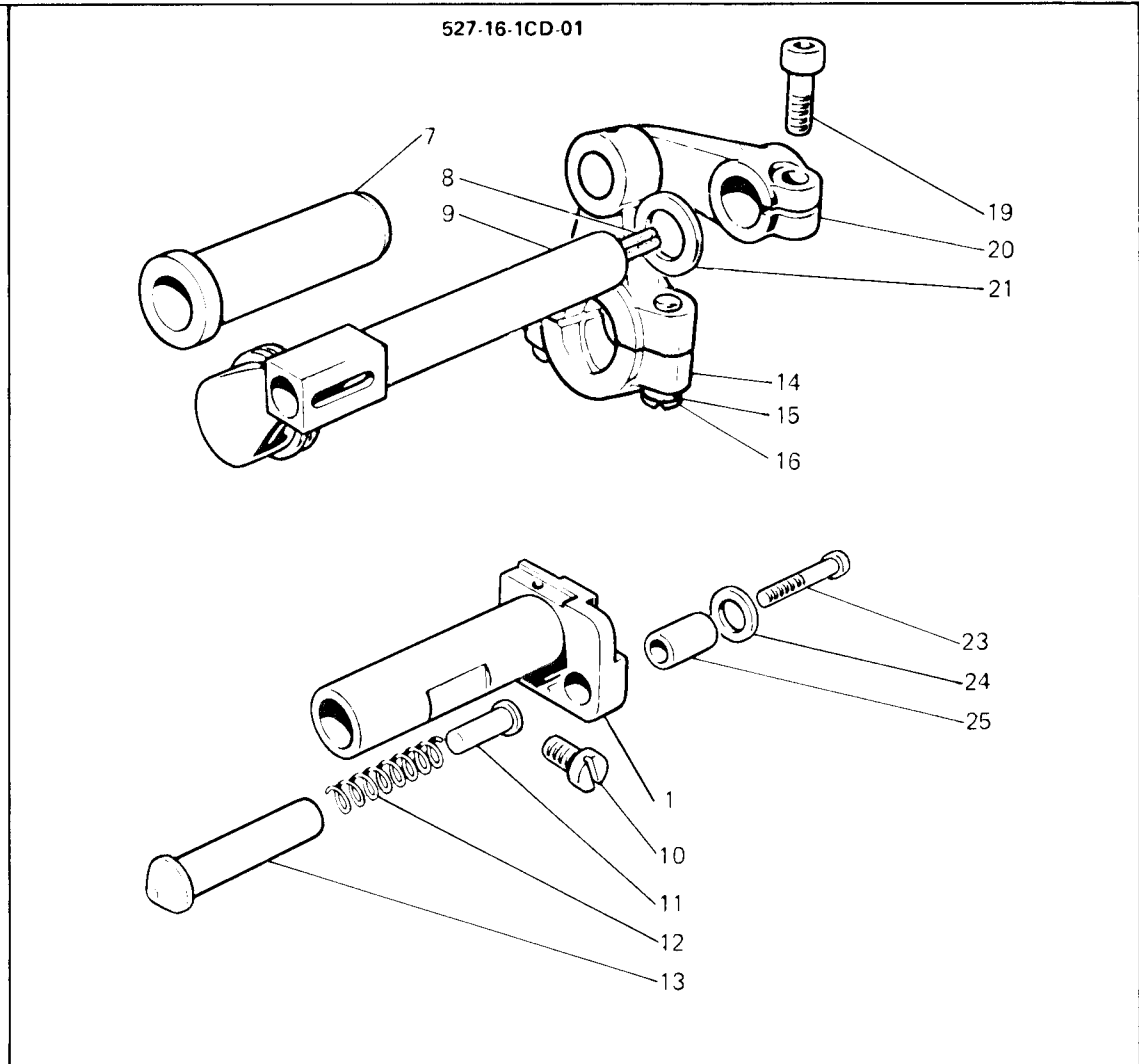
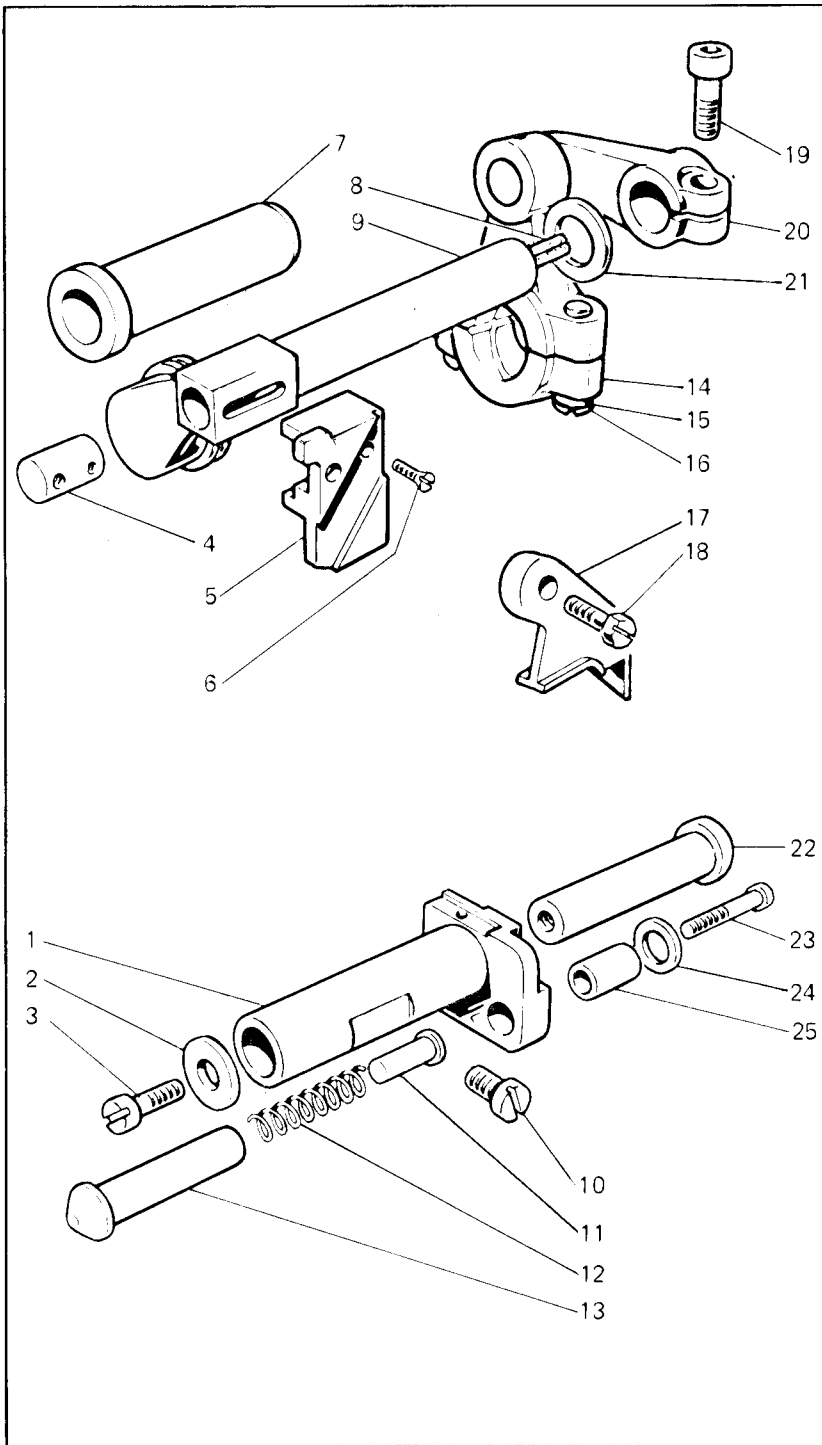

Fig. N. Abb. N.	Part. N. Piece N. Bestell N. Pieza N.	Qt. Anzahl	DESCRIZIONE	DESCRIPTION	DESCRIPTION
1	207111-0-00	1	porta coltello inferiore	lower knife holding	porte couteau inférieur
2	704409-2-00	1	rondella	washer	rondelle
3	742457-2-00	1	vite	screw	vis
4	202130-0-11	1	perno	pin	pivot
5	207588-0-00	1	placchetta	plate	plaque
6	744533-0-00	1	vite	screw	vis
7	206539-0-01	1	bussola	bush	bague
8	778835-0-00	1	stoppino	wick	mèche
9	207861-4-00	1	albero colt. sup. con stoppino	shaft	arbre
10	742758-0-00	1	vite	screw	vis
11	206758-0-00	1	puntalino	pin	pivot
12	202128-0-10	1	molla	spring	ressort
13	206757-0-00	1	bussola	bush	bague
14	208521-2-00	1	biella completa	con-rod assembly	bielle compl.
15	704213-2-00	2	rondella	washer	rondelle
16	743469-2-00	2	vite	screw	vis
17	207589-0-00	1	staffa	bracket	équerre
18	207421-0-01	1	vite	screw	vis
19	744334-2-00	1	vite	screw	vis
20	206574-2-01	1	manovella alb. coltello sup.	crank for upper knife shaft	manivelle arbre couteau sup.
21	705030-0-00	1	rondella	washer	rondelle
22	202134-0-11	1	perno	pin	pivot
23	722471-2-00	1	vite	screw	vis
24	704406-0-00	1	rondella	washer	rondelle
25	202129-0-10	1	bussola	bush	bague
26	203810-0-10	1	bussola	bush	bague
27	207586-0-00	1	placchetta	plate	plaque
28	744553-0-00	1	vite	screw	vis
29	207417-0-00	1	vite	screw	vis
30	200662-0-10	1	carterino	cover	car ter

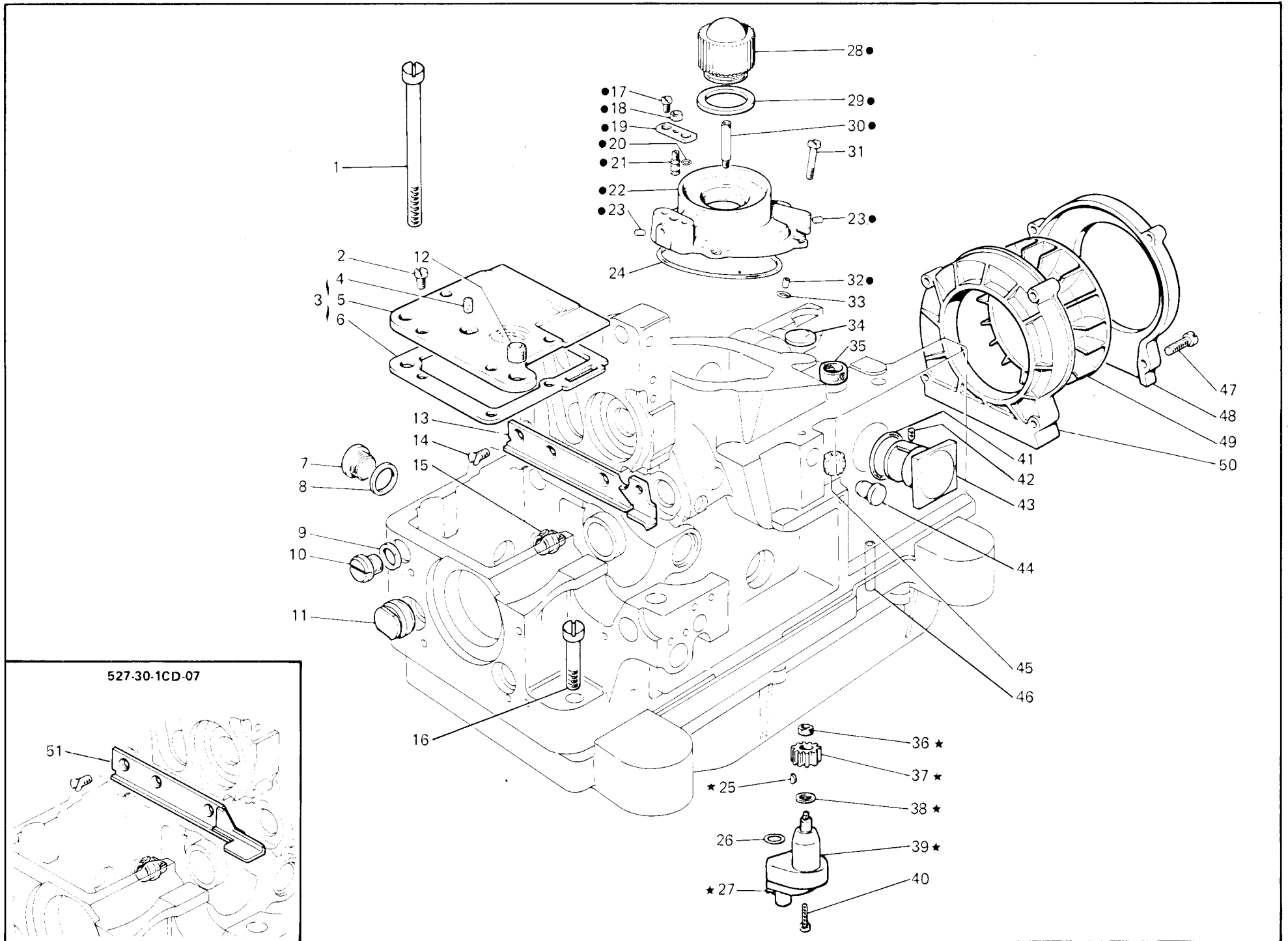

Fig. N. Abb. N.	Part. N. Pezze N. Bestell N. Pieza N.	Qt. Anzahl	DESCRIZIONE	DESCRIPTION	DESCRIPTION
●	207972-4-01	1	coperchio distrib. olio compl.	oil distributor cover assembly	calotte distribution huile compl.
★	206550-4-03	1	gruppo pompa olio	oil pump assembly	groupe pompe à huile
1	207917-0-00	4	vite fissa bacinella	screw	vis
2	721443-2-00	4	vite	screw	vis
3	207951-4-00	1	coperchio completo	cover assembly	couvercle complet
4	778241-0-00	1	stoppino	wick	mèche
5	207952-2-00	1	coperchio	cover	couvercle
6	207953-0-00	1	guarnizione	gasket	garniture
7	202026-0-10	1	tappo	plug	bouchon
8	705982-0-00	1	guarnizione	gasket	garniture
9	705975-0-00	1	guarnizione	gasket	garniture
10	202480-0-10	1	tappo	plug	bouchon
11	202027-0-10	1	tappo	plug	bouchon
12	207954-0-00	1	tappo	plug	bouchon
13	207961-0-00	1	carterino	cover	carter
14	744730-2-00	3	vite	screw	vis
15	206619-0-00	1	vaschetta olio	oil sump	cuvette huile
16	742086-2-00	1	vite fissa bacinella	screw	vis
17	741535-0-00	2	vite	screw	vis
18	746007-2-00	1	dado	nut	écrou
19	207979-0-00	1	piastrina	plate	plaque
20	701002-0-00	1	anello di tenuta	retainer ring	bague d'étanchéité
21	207978-0-00	1	pistoncino	piston	piston
22	207970-2-01	1	coperchio con tappo	cover with plug	couvercle avec bouchon
23	301586-0-10	2	tappo	plug	bouchon
24	701151-0-00	1	anello di tenuta	retainer ring	bague d'étanchéité
25	206557-0-00	1	chiavetta	key	clavette
26	701004-0-00	1	anello di tenuta	retainer ring	bague d'étanchéité
27	721494-2-00	2	vite	screw	vis
28	207973-0-01	1	cupolina	cup	coupole
29	705970-0-00	1	guarnizione	gasket	garniture
30	207971-0-00	1	ugello	nozzle	gicleur
31	722063-2-00	6	vite	screw	vis
32	207977-0-00	1	bussolina	bush	bague
33	701106-0-00	1	anello di tenuta	retainer ring	bague d'étanchéité
34	206748-0-00	1	tappo espansione	plug	bouchon
35	206667-0-01	1	tappo decompressione	plug	bouchon
36	733507-2-00	1	dado	nut	écrou
37	206555-0-02	1	ruota	wheel	roue
38	704813-0-00	1	rondella	washer	rondelle
39	206554-0-02	1	coperchio	cover	couvercle
40	722511-2-00	2	vite	screw	vis
41	701031-0-00	1	anello di tenuta	retainer ring	bague d'étanchéité
42	729022-2-00	1	vite	screw	vis
43	208087-3-00	1	indicatore livello olio	oil level gauge	indicateur niveau huile
44	202398-0-10	1	tappo	plug	bouchon
45	207758-0-01	1	bussola guida astina	bush	bague
46	206296-0-00	1	tubetto scarico olio	pipe	tube
47	202484-0-10	4	vite	screw	vis
48	206687-2-00	1	coperchio coclea	cover	couvercle
49	206690-2-00	1	ventola di raffreddamento	cooling fan	ventilateur
50	206688-0-00	1	coclea per ventola	scroll	palier
51	208010-0-00	1	carterino	cover	carter

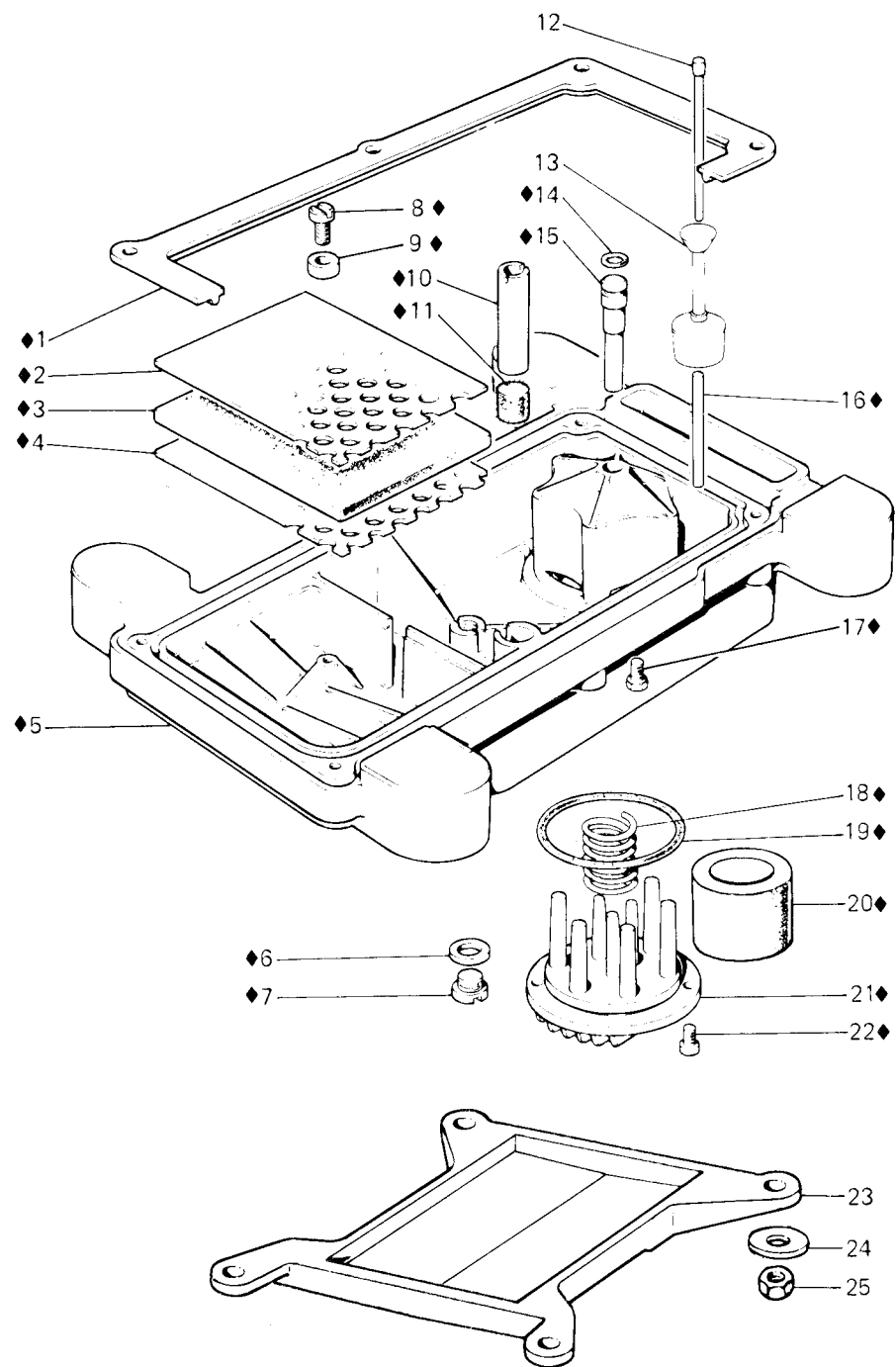

Fig. N. Abb. N.	Part. N. Piece N. Bestell N. Pieza N.	Qt. Anzahl	DESCRIZIONE	DESCRIPTION	DESCRIPTION
◆	208012-4-01	1	bacinella olio completa	oil sump assembly	réservoir huile compl.
1	207909-0-00	1	guarnizione bacinella	oil sump gasket	garniture réservoir
2	206567-0-01	1	lamiera forata superiore	upper sheet	plaque perforée supérieur
3	206566-0-00	1	filtro	filter	filtre
4	206565-0-01	1	lamiera forata inferiore	lower sheet	plaque perforée inférieur
5	207901-0-01	1	bacinella	oil sump	réservoir
6	705977-0-00	1	rondella	washer	rondelle
7	206564-0-00	1	tappo	plug	bouchon
8	721484-2-00	1	vite	screw	vis
9	990335-0-10	1	distanziale	spacer	entretoise
10	206568-0-01	1	tubetto	pipe	tube
11	206569-0-01	1	filtro	filter	filtre
12	207975-0-00	1	astina indicat. livello olio	oil sump stick	jauge niveau huile
13	206665-2-00	1	galleggiante	float	flotteur
14	701005-0-00	1	anello di tenuta	retainer ring	bague d'étanchéité
15	206558-0-01	1	tubo aspirante	pipe	tube
16	206662-0-00	1	spina	pin	goupille
17	720411-2-00	1	vite	screw	vis
18	206545-0-00	1	spirale per coperchio	spiral for cover	spirale pour couvercle
19	701051-0-00	1	guarnizione	gasket	garniture
20	206559-0-01	1	filtro	filter	filtre
21	206560-0-10	1	coperchio	cover	couvercle
22	722063-2-00	2	vite	screw	vis
23	991218-0-00	1	sottobacinella	underban	sous-réservoir
24	704536-0-00	4	rondella	washer	rondelle
25	733008-2-00	4	dado	nut	écrou

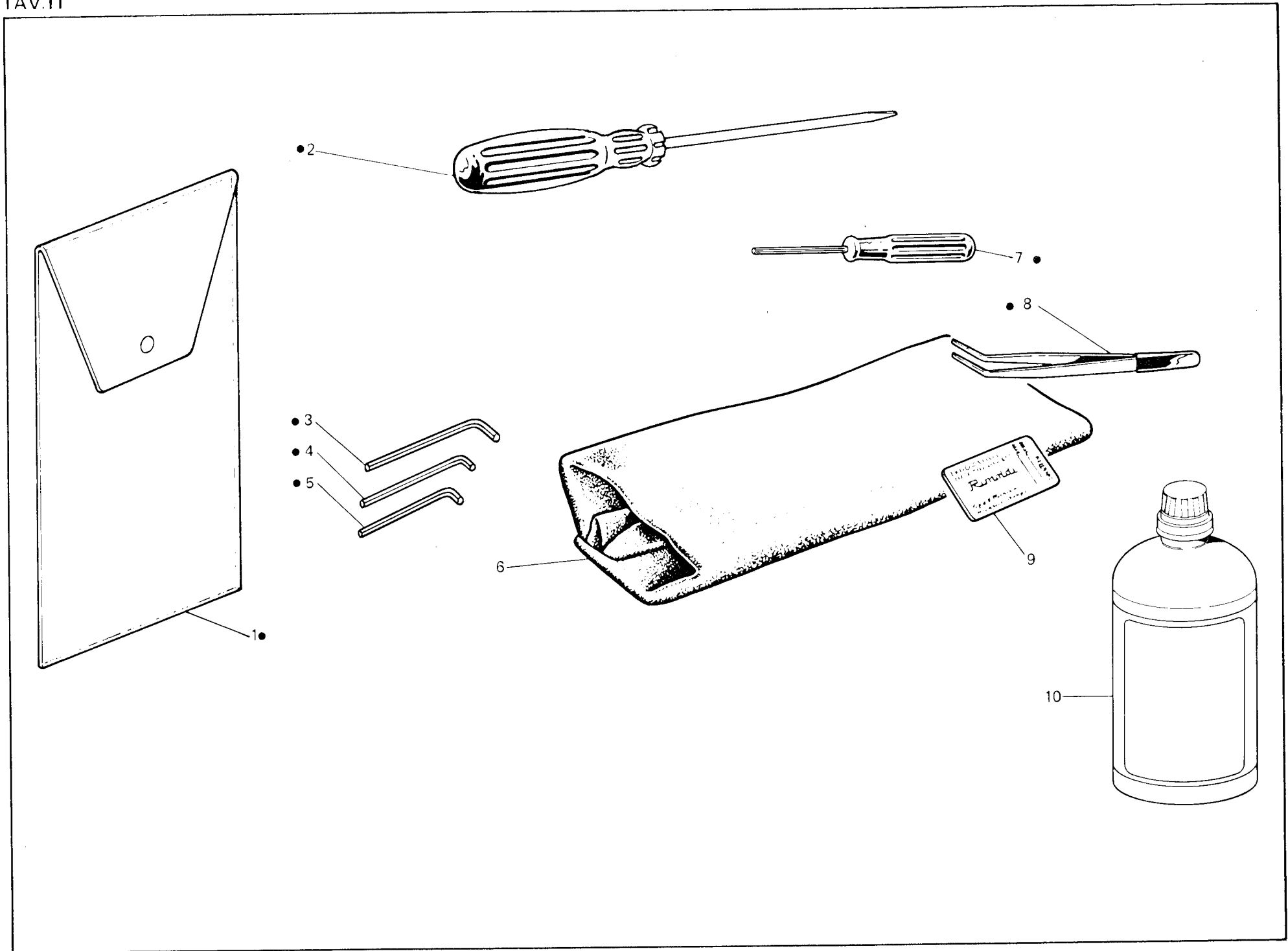

Fig. N. Abb. N.	Part. N. Piece N. Bestell N. Pieza N.	Qt. Anzahl	DESCRIZIONE	DESCRIPTION	DESCRIPTION
●	991400-4-02	1	busta accessori completa	accessories envelope assembly	envelope accessoires complète
1	991415-0-00	1	busta accessori	accessories envelope	envelope accessoires
2	990723-0-00	1	cacciavite medio	screw driver	tournevis moyen
3	990639-0-10	1	chiave esag. da 3 mm	3 mm hexagonal key	clé hexagonale de 3 mm
4	990685-0-10	1	chiave esag. da 2,5 mm	2,5 mm hexagonal key	clé hexagonale de 2,5 mm
5	990325-0-10	1	chiave esag. da 2 mm	2 mm hexagonal key	clé hexagonale de 2 mm
6	990183-0-13	1	cuffia protezione testa	machine cover	couverture protection tête
7	990474-0-11	1	chiave esag. da 1,5 mm	1,5 mm hexagonal key	clé hexagonale de 1,5 mm
8	990176-0-10	1	pinza per infilatura	threading clers	pince pour enfilage
9	★	1	bustina aghi	needles packet	paquette aiguilles
10	991284-0-00	1	lattina olio	oil container	bidon de huile
			★ per l'ordinazione della bustina citare lo stesso simbolo dell'ago montato sulla testa	to order packet of needles please specify symbol of needle fitted on machine	pour commander un sachet d'aiguille donner le symbol de l'aiguille montée sur la tête

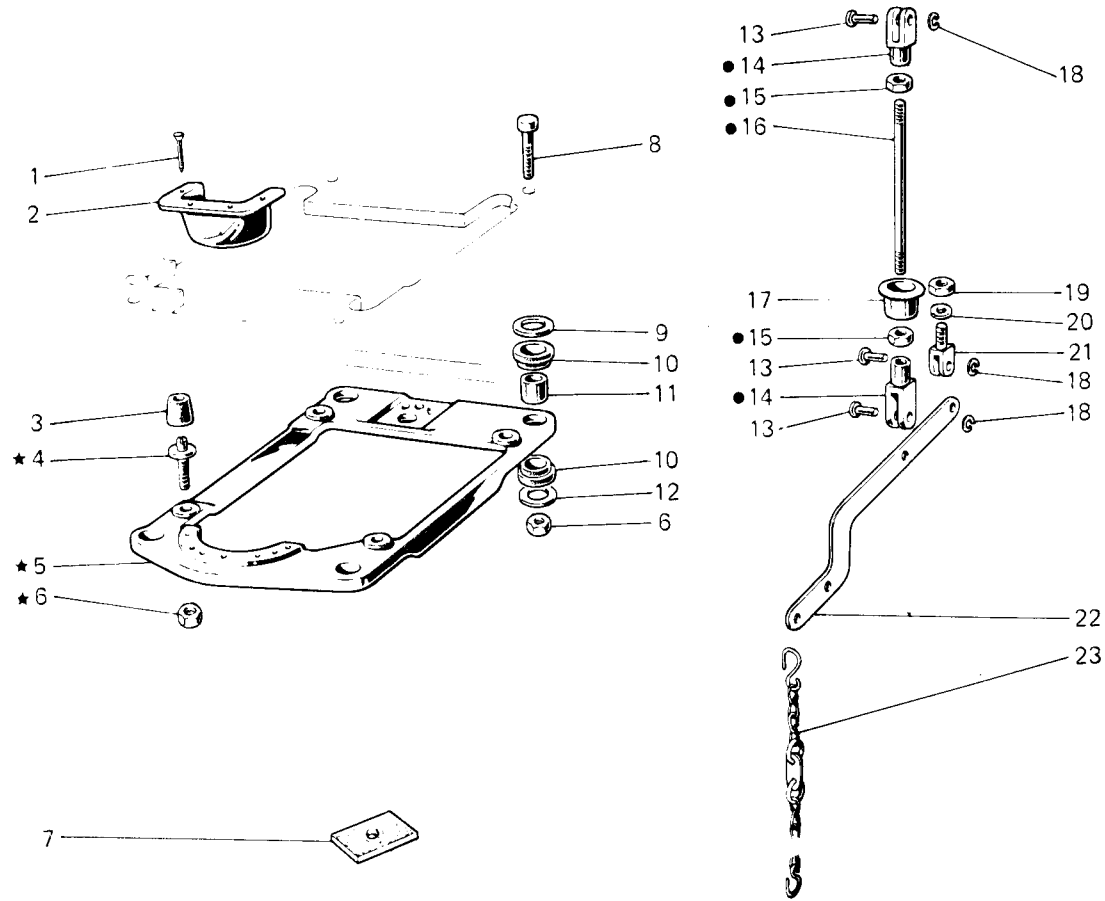

Fig. N. Abb. N.	Part. N. Piece N. Bestell N. Pieza N.	Qt. Anzahl	DESCRIZIONE	DESCRIPTION	DESCRIPTION
★	990987-4-00	1	supporto testa completo	head support assembly	support tête complet
●	990984-4-10	1	tirante alza piedino completo	presser tie-rod assembly	tirant pour soulèv. pied-presseur
1	900201-0-10	4	chiodino	rivet	clou
2	991187-0-00	1	bocchetta	cup	bouche
3	990982-0-00	4	ammortizzatore	shock absorber	amortisseur
4	900694-0-11	4	perno	pin	pivot
5	990981-0-00	1	supporto testa	head support	support tête
6	733008-2-00	8	dado	nut	écrou
7	900203-0-10	4	ammortizzatori per tavola	shock absorber	amortisseur
8	722905-2-00	4	vite	screw	vis
9	704346-2-00	4	rondella	washer	rondelle
10	901101-0-00	8	ammortizzatore	shock absorber	amortisseur
11	901102-0-00	4	distanziale	spacer	entretoise
12	704345-2-00	4	rondella	washer	rondelle
13	990311-0-10	3	perno	pin	pivot
14	990310-0-10	2	giunto	joint	joint
15	746402-2-00	2	dado	nut	écrou
16	990452-0-00	1	tirante	tie-rod	tirant
17	900204-0-10	1	bussola	bush	bague
18	700205-0-00	3	anello elastico	spring ring	anneau ressort
19	746409-2-00	1	dado	nut	écrou
20	704424-2-00	1	rondella	washer	rondelle
21	990314-0-10	1	supportino	support	support
22	990316-0-11	1	leva	lever	levier
23	990179-4-11	1	catenella completa	chain assembly	chaînette complète

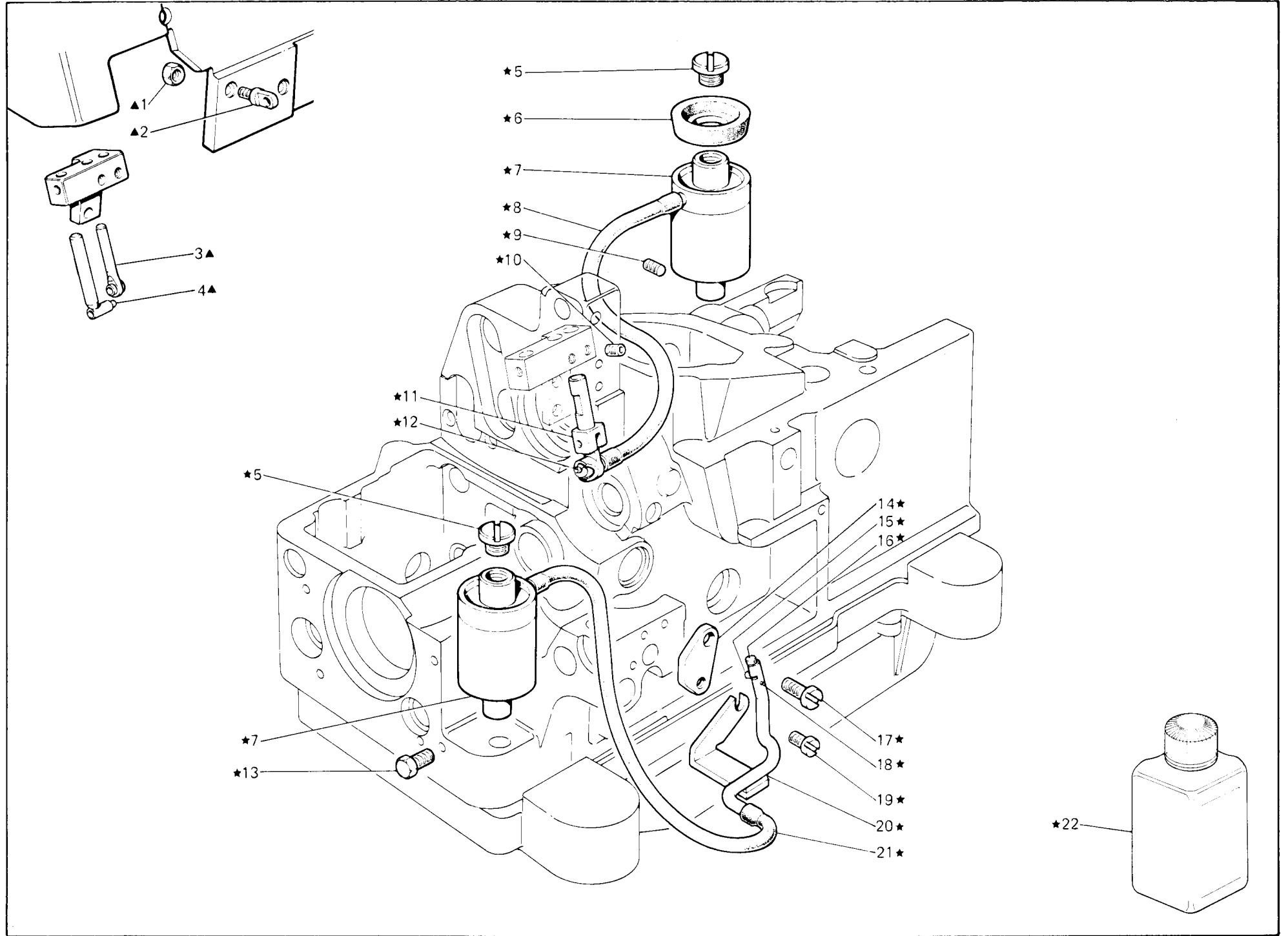

Fig. N. Abb. N.	Part. Piecce Bestell Pieza	N. N. N. N.	Qt. Anzahl	DESCRIZIONE	DESCRIPTION	DESCRIPTION
				A RICHIESTA	ON REQUEST	SUR DEMANDE
★	208350-4-00		1	gruppo lubrificazione al silicone	silicone lubrication assembly	groupe lubrification à silicone
▲	208310-4-00		1	gruppo passafili	thread guide assembly	group passe-fil
1	733503-0-00		3	dado	nut	écrou
2	208204-2-00		3	passafilo	thread guide	passe-fil
3	208179-2-00		1	passafilo	thread guide	passe-fil
4	208196-3-00		1	passafilo	thread guide	passe-fil
5	207969-0-00		2	tappo	plug	bouchon
6	207976-0-00		2	contenitore silicone	container	container
7	740041-2-00		1	vite	screw	vis
8	208219-3-00		1	supporto snodato completo	support assembly	support complet
9	778842-0-00		1	stoppino	wick	mèche
10	208019-0-00		1	guarnizione	gasket	garniture
11	208208-0-00		1	guaina	sheath	gaine
12	729013-2-00		1	vite	screw	vis
13	745800-2-00		1	vite	screw	vis
14	208144-0-00		1	piastra	plate	plaque
15	778837-0-00		1	stoppino	wick	mèche
16	778237-0-00		1	stoppino	wick	mèche
17	722073-2-00		1	vite	screw	vis
18	208209-0-00		1	spina	pin	goupille
19	741634-2-00		1	vite	screw	vis
20	208148-4-00		1	gruppo tubetto	pipe assembly	groupe tube
21	208207-0-00		1	guaina	sheath	gaine
22	990934-0-00		1	barattolo olio silicone	silicone oil tin	cuve d'huile à la silicone

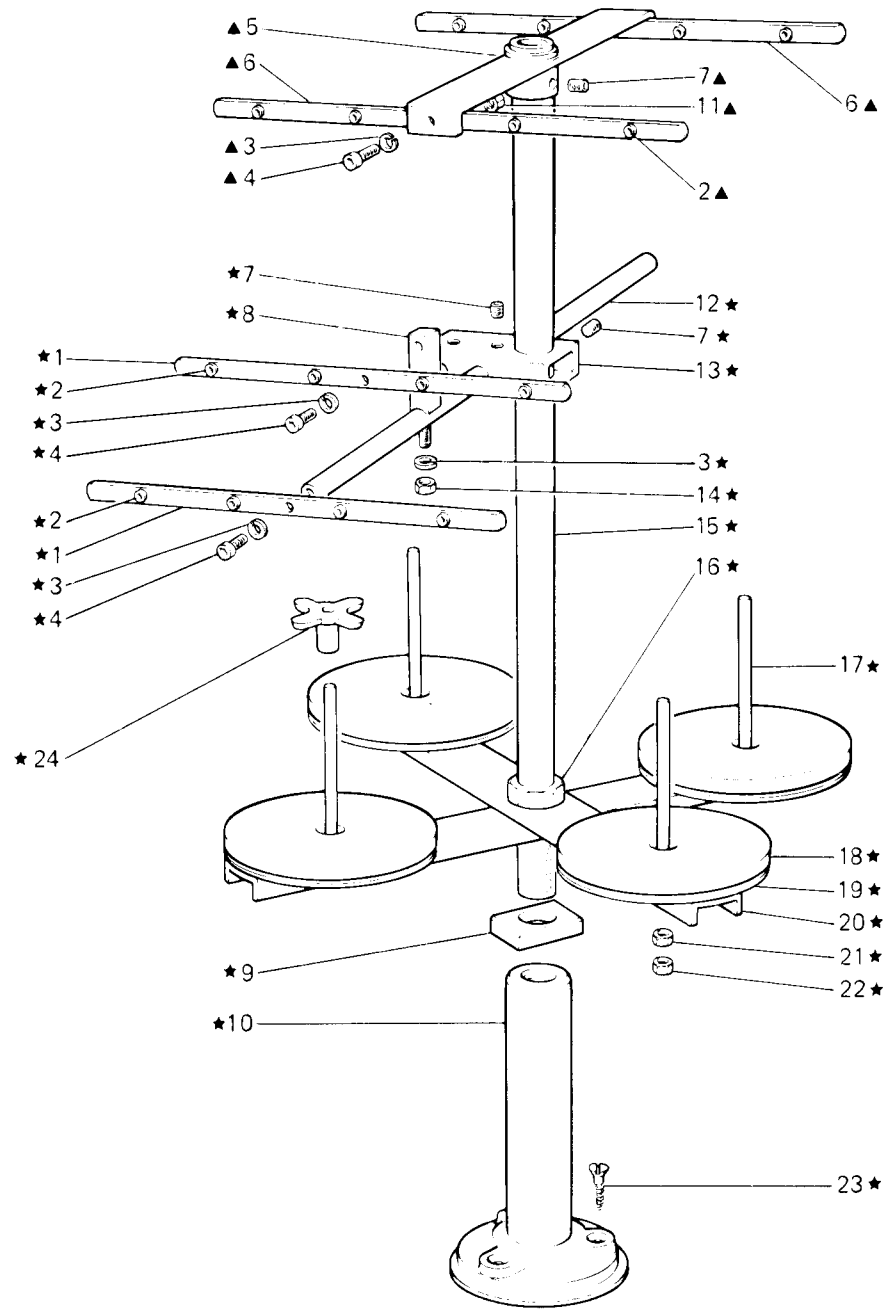

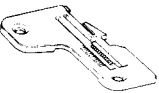

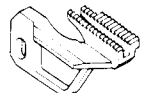





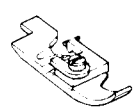











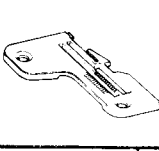
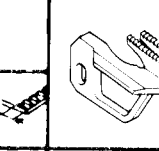
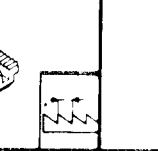
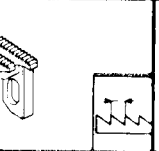
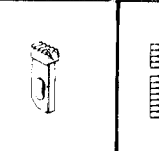
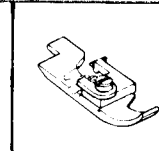

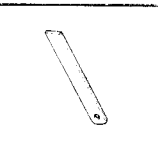

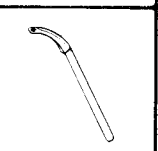



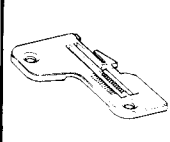
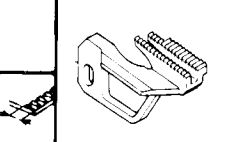
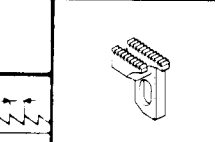
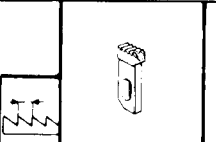
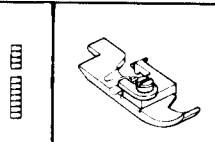
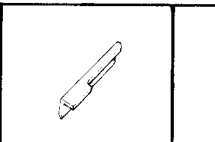
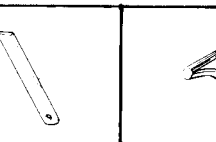
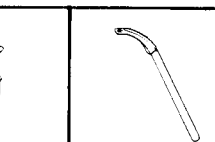

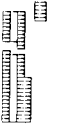
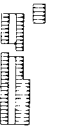



Fig. N. Abb. N.	Part. N. Piece N. Bestell N. Pieza N.	Qt. Anzahl	DESCRIZIONE	DESCRIPTION	DESCRIPTION
▲ ★	991120-5-01	1	porta bobine completo 3-4- fili	bobbin carrier 3-4- threads	porte bobine compl. 3-4- fils
▲	991194-4-00	1	telaio completo	frame assembly	bâti complet
1	991108-2-01	2	piattina	disc	plateau
2	991268-0-00	12	bussolina	bush	bague
3	703005-0-00	6	rondella elastica	spring washer	rondelle élastique
4	722431-2-00	6	vite	screw	vis
5	991247-2-00	1	traversa con mozzo	tie with hub	traverse avec moyeau
6	991126-0-10	2	piattina	disc	plateau
7	729034-2-00	3	vite	screw	vis
8	991269-2-00	1	supporto completo	support assembly	support complet
9	991172-0-00	2	distanziale	spacer	entretoise
10	991174-0-00	1	base	base	base
11	733505-2-00	2	dado	nut	écrou
12	991264-2-00	1	asta	rod	tige
13	991279-2-00	1	blocchetto	block	block
14	733806-2-00	1	dado	nut	écrou
15	991206-0-00	1	tubo	pipe	tube
16	733211-2-00	1	dado	nut	écrou
17	991111-2-00	4	astina con dadi	rod with nut	tige avec écrou
18	991179-0-01	4	disco	disc	disque
19	991112-0-00	4	piatto	disc	plateau
20	991199-0-00	2	traversa	tie	traverse
21	733508-2-00	4	dado	nut	écrou
22	925433-0-00	4	dado	nut	écrou
23	731506-2-00	3	vite da legno	screw	vis
			SOLO A RICHIESTA	ONLY ON REQUEST	SEULEMENT SUR DEMANDE
24	991134-0-00	4	centrabobine	bobbin center	centre bobine

ORGANI DI CUCITURA				SEWING PARTS				ORGANES DE COUTURE													
R = A RICHIESTA G = GRIFFE GOMMATE ● ▲ ★ = ABBINAMENTI OBBLIGATORI				ON REQUEST RUBBERED FEED DOGS FIXED COUPLINGS				SUR DEMANDE GRIFFES CAOUTCHOUEES JUMELAGES OBLIGES													
527.00-1CD-01	202504-0-11 202148-0-11 202506-4-11● 202507-0-11 202508-0-11 202590-0-11	R R R R R	4,1 4,6 4,1 5 5,6 6	202053-0-10 202056-2-11★ 202517-0-00 202757-0-00▲	R R R	G 1 1,5	202057-0-10 202060-2-11★ 202559-0-00 202758-0-00▲	R R R	1,5 G 1 1,5	202061-0-10		202171-3-11 202172-3-11 202173-3-11● 202509-3-11	R R R	202142-0-10 202143-0-10 207000-2-00 207008-2-00	R R R	202146-0-10 207015-2-00	R	202095-0-11 202094-0-11	R	204021-0-10 202092-0-11 204033-0-10	R R
527.00-1CD-02	202707-0-11 202634-0-11 202635-0-11 202636-0-11 202709-0-11 202716-0-11 202738-4-01●	R R R R R R	2 2,5 3,5 1,2 1,5 3 3,5	202605-0-10 202695-0-10	R	1,5 1	202608-0-10 202699-0-10	R	1,5 1	202609-0-10		202642-3-11 202732-3-01●	R	207000-2-00 202142-0-10 202143-0-10 207008-2-00	R R R	207015-2-00 202146-0-10	R	202094-0-11		204033-0-10	
527.00-1CD-07	203214-0-11 203216-4-11● 203217-0-11 203218-0-11 203219-0-11	R R R R	3,3 3,3 4 5 3,8	203199-0-10 202517-0-00 203201-2-11★	R R	1,5 1 G	202057-0-10 202060-2-11★ 202559-0-00	R R	1,5 G 1	202061-0-10		202171-3-11 202172-3-11 202173-3-11● 202509-3-11	R R R	202142-0-10 202143-0-10 207000-2-00 207008-2-00	R R R	202146-0-10 207015-0-10	R	202094-0-11 202095-0-11	R	204033-0-10 204021-0-10	R
527.00-1CD-20	202504-0-11 202148-0-11 202507-0-11 202508-0-11 202590-0-11	R R R R	4,1 4,6 5 5,6 6	207077-0-00		1,5	207079-0-00		1,5	202061-0-10		202171-3-11		202143-0-10 202142-0-10	R	202146-0-10		202095-0-11 202094-0-11	R	206209-0-00 206208-0-00	R
527.00-1CD-21	203035-0-12 203014-0-12 203037-0-12	R R	3,3 7 3,1	203028-0-10 203001-0-10 203030-2-11★ 207027-0-00	R R R	1,5 2 G 1	203031-0-10 203002-0-10 203033-2-11★ 207028-0-00	R R R	1,5 2 G 1	203004-0-10		208365-3-00		207001-2-00 207006-2-00	R	207016-2-00 203012-0-10 207017-2-00	R R	202094-0-11		204033-0-10	
527.00-1CD-25	203047-0-21 203048-0-21	R	3 3,5	203060-0-10 203095-2-00★	R R	1,5 G	203062-0-10 203094-2-00★	R R	1,5 G	202609-0-10		203050-3-11 207100-3-01	R	207006-2-00 203066-0-10	R	207024-2-00 203144-0-10	R	202094-0-11		204033-0-10	

ORGANI DI CUCITURA				SEWING PARTS				ORGANES DE COUTURE					
R = A RICHIESTA G = GRIFFE GOMMATE ● ▲ ★ = ABBINAMENTI OBBLIGATORI				ON REQUEST RUBBERED FEED DOGS FIXED COUPLINGS				SUR DEMANDE GRIFFES CAOUTCHOUTEES JUMELAGES OBLIGES					
													
527-00-1CD-26	207072-0-11	2	203060-0-10 203095-2-00★ R	1,5 G	203062-0-10 203094-2-00★ R	1,5 G	202061-0-10		203077-0-10	203066-0-10 207006-2-00 R	203069-0-10 207017-2-00 R	202094-0-11 202095-0-11 R	203033-0-10 204021-0-10 R
527-00-1CD-29	203813-0-11	5	203060-0-10 203095-2-00★ R	1,5 G	203062-0-10 203094-2-00★ R	1,5 G	202061-0-10		203815-3-11	203812-0-10 207007-2-00 R	203069-0-10 207017-2-00 R	202094-0-11 202095-0-11 R	204033-0-10 204021-0-10 R
527-00-1CD-31	203219-0-11	3,8	203199-0-10 203201-2-11★ R	1,5 G	202057-0-10 202060-2-11★ R	1,5 G	202609-0-10		203162-3-11	207000-2-00 202142-0-10 R 202143-0-10 R 207008-2-00 R	207015-2-00 202146-0-10 R	202094-0-11	204033-0-10
527-01-1CD-01	202504-0-11 202148-0-11 R 202507-0-11 R 202508-0-11 R 202590-0-11 R	4,1 4,6 5 5,6 6	202053-0-10 202056-2-11★ R 202517-0-00 R	1,5 G 1	202057-0-10 202060-2-11★ R 202559-0-00 R	1,5 G 1	202061-0-10		203157-3-11 202172-3-11 R 202059-3-11 R	202142-0-10 202143-0-10 R 207000-2-00 R 207008-2-00 R	202146-0-10 207015-2-00 R	202095-0-11	204021-0-10
527-01-1CD-02	202504-0-11 202148-0-11 R 202507-0-11 R 202508-0-11 R 202590-0-11 R	4,1 4,6 5 5,6 6	202053-0-10 202056-2-11★ R 202517-0-00 R	1,5 G 1	202057-0-10 202060-2-11★ R 202559-0-00 R	1,5 G 1	202061-0-10		202178-3-11	202142-0-10 202143-0-10 R 207000-2-00 R 207008-2-00 R	202146-0-10 207015-2-00 R	202095-0-11	204021-0-10
527-01-1CD-04	203214-0-11 203217-0-11 R 203218-0-11 R 203220-0-11 R	3,3 4 5 2,8	203199-0-10 203201-2-11★ R	1,5 G	202057-0-10 202060-2-11★ R	1,5 G	202061-0-10		202178-3-11	202142-0-10 202143-0-10 R 207000-2-00 R 207008-2-00 R	202146-0-10 207015-2-00 R	202094-0-11	204033-0-10

ORGANI DI CUCITURA		SEWING PARTS						ORGANES DE COUTURE							
R = A RICHIESTA G = GRIFFE GOMMATE ● ▲ ★ = ABBINAMENTI OBBLIGATORI		ON REQUEST RUBBERED FEED DOGS FIXED COUPLINGS						SUR DEMANDE GRIFFES CAOUTCHOUTEES JUMELAGES OBLIGES							
527-01-1CD-05	203219-0-11	3,8	203199-0-10	1,5	202057-0-10	1,5	202609-0-10		202178-3-11	202142-0-10 202143-0-10 207000-2-00 207008-2-00	R R R	202146-0-10 207015-2-00	R	202094-0-11	204033-0-10
527-01-1CD-09	203219-0-11	3,8	203199-0-10 203201-2-11★ R	1,5 G	202057-0-10 202060-2-11★ R	1,5 G	202609-0-10		205892-3-00	207000-2-00 202142-0-10 202143-0-10 207008-2-00	R R R	207015-2-00 202146-0-10	R	202094-0-11	204033-0-10
527-10-1CD-02	202783-0-11 202876-0-11 202877-0-11 206297-0-01	R 3,2 R 3 R 5 R 3,2	202780-0-10	1,5	202782-0-10	1,5	202061-0-10		202786-3-11	202142-0-10 202143-0-10 207000-2-00 207008-2-00	R R R	202146-0-10 207015-2-00	R	202094-0-11 202095-0-11	R 202092-0-11 204033-0-10 204021-0-10
527-10-1CD-06	202783-0-11	3,2	202780-0-10	1,5	202782-0-10	1,5	202061-0-10		202786-3-11 206350-3-00	R 202142-0-10 202143-0-10 207000-2-00 2070008-2-00	R R R	202146-0-10 207015-2-00	R	202094-0-11	202092-0-11 204033-0-10
527-16-1CD-01	202149-0-11	5	202054-0-10	1,5	202058-0-11	1,5	202061-0-10		202177-3-11					202095-0-11	204021-0-10
527-22-1CD-02	203148-0-11	4,5	203140-0-10	1,5	203141-0-10	1,5	202061-0-10		203157-3-11 203765-3-11	R 202142-0-10 202143-0-10 207000-2-00 207008-2-00	R R R	202146-0-10 207015-2-00	R	202094-0-11	204033-0-10

ORGANI DI CUCITURA				SEWING PARTS				ORGANES DE COUTURE							
R = A RICHIESTA G = GRIFFE GOMMATE ● ▲ ★ = ABBINAMENTI OBBLIGATORI				ON REQUEST RUBBERED FEED DOGS FIXED COUPLINGS				SUR DEMANDE GRIFFES CAOUTCHOUTEES JUMELAGES OBLIGES							
															
527-22-1CD-03	203150-0-11	3,5	203140-0-10	1,5	203141-0-10	1,5	202061-0-10		203159-3-11	202142-0-10 202143-0-10 207000-2-00 207008-2-00	R R R	203144-0-10 207024-2-00	R	202094-0-11	204033-0-10
527-22-1CD-04	203280-0-11	2,5	203270-0-10	1	203271-0-11	1	202061-0-10		203157-3-11	202142-0-10 202143-0-10 207000-2-00 207008-2-00	R R R	202146-0-10 207015-2-00	R	202094-0-11	204033-0-10
527-23-1CD-02	203148-0-11 203149-0-11	R 4,5 5	203140-0-10	1,5	203141-0-10	1,5	202061-0-10		203160-3-11	202142-0-10 202143-0-10 207000-2-00 207008-2-00	R R R	202146-0-10 207015-2-00	R	202094-0-11	204033-0-10
527-28-1CD-02	202507-0-11 202148-0-11 202504-0-11 202508-0-11 202590-0-11	R 5 4,6 4,1 5,6 6	202053-0-10 202517-0-00 202757-0-00★	R 1 1,5	202057-0-10 202559-0-00 202758-0-00★	R 1 1,5	202061-0-10		202774-3-11	207000-2-00 202142-0-10 202143-0-10 207008-2-00	R R R	207015-2-00 202146-0-10	R	202095-0-11 202094-0-11	R 202092-0-11 204021-0-10 204033-0-10
527-28-1CD-09	202636-0-11	1,2	202605-0-10 202695-0-10	R 1	202608-0-10 202699-0-10	R 1	202609-0-10		202643-3-11	207000-2-00 202142-0-10 202143-0-10 207008-2-00	R R R	207015-2-00 202146-0-10	R	202094-0-11	204033-0-10
527-29-1CD-01	202504-0-11 202148-0-11 202507-0-11 202508-0-11 202590-0-11	R 4,1 4,6 5 5,6 6	202053-0-10 202056-2-11★ 202517-0-00	R G 1	202057-0-10 202060-2-11★ 202559-0-00	R G 1	202061-0-10		202175-3-11	203066-0-10 207006-2-00	R	202146-0-10 207015-2-00	R	202095-0-11	204021-0-10

ORGANI DI CUCITURA		SEWING PARTS		ORGANES DE COUTURE									
R= A RICHIESTA G= GRIFFE GOMMATE ● ▲ ★ = ABBINAMENTI OBBLIGATORI		ON REQUEST RUBBERED FEED DOGS FIXED COUPLINGS		SUR DEMANDE GRIFFES CAOUTCHOUTEES JUMELAGES OBLIGES									
													
527-29-1CD-02	202504-0-11 202148-0-11 R 202507-0-11 R 202508-0-11 R 202590-0-11 R	4,1 4,6 5 5,6 6	202053-0-10 202056-2-11★ R 202517-0-00 R	1,5 G 1	202057-0-10 202060-2-11★ R 202559-0-00 R	1,5 G 1	202061-0-10		202176-3-11	203066-0-10 207006-2-00 R	202146-0-10 207015-2-00 R	202095-0-11	204021-0-10
527-29-1CD-05	203214-0-11 203217-0-11 R 203218-0-11 R 203220-0-11 R	3,3 4 5 2,8	203199-0-10 203201-2-11★ R	1,5 G	202057-0-10 202060-2-11★ R	1,5 G	202061-0-10		202175-3-11	203066-0-10 207006-2-00 R	202146-0-10 207015-2-00 R	202094-0-11	204033-0-10
527-29-1CD-06	203219-0-11 203217-0-11 R 203218-0-11 R 203220-0-11 R	3,3 4 5 2,8	203199-0-10 203201-2-11★ R	1,5 G	202057-0-10 202060-2-11★ R	1,5 G	202061-0-10		202176-3-11	203066-0-10 207006-2-00 R	202146-0-10 207015-2-00 R	202094-0-11	204033-0-10
527-30-1CD-07	203218-0-11	3,8	205951-0-00 206293-2-00★ R	1,5 G	205952-0-00 206295-2-01★ R	1,5 G	202609-0-10		205954-3-01	207000-2-00 202142-0-10 202143-0-10 207008-2-00 R	207015-2-00 202146-0-10 R	202094-0-11	202090-0-11
527-34-1CD-01	202504-0-11 202148-0-11 R 202507-0-11 R 202508-0-11 R 202590-0-11 R	4,1 4,6 5 5,6 6	202542-0-10	1,5	203265-0-11	1,5	202061-0-10		206140-3-02	202142-0-10 207000-2-00 207008-2-00 R	202146-0-10 207015-2-00 R	202095-0-11	204021-0-10
527-38-1CD-01	203219-0-11	3,8	203199-0-10	1,5	202057-0-10	1,5	202609-0-10		203162-3-11	207000-2-00	207015-2-00	202094-0-11	204033-0-10

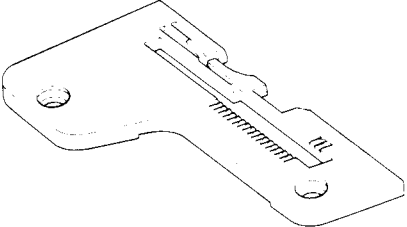
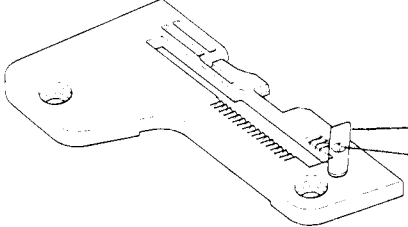
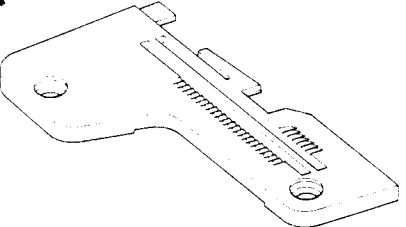
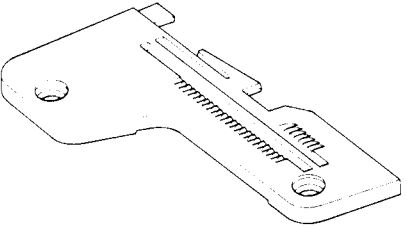
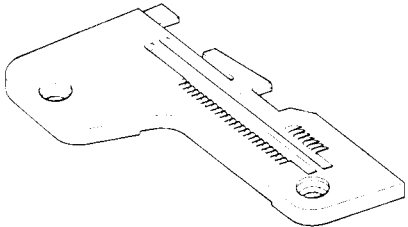
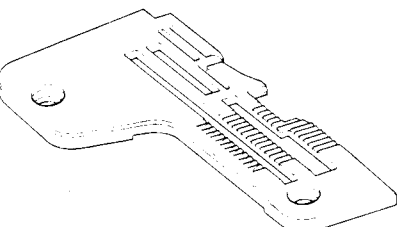
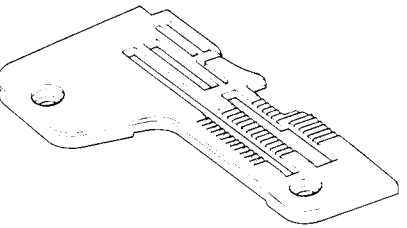
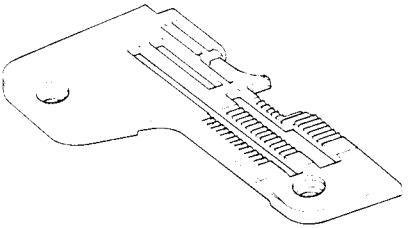
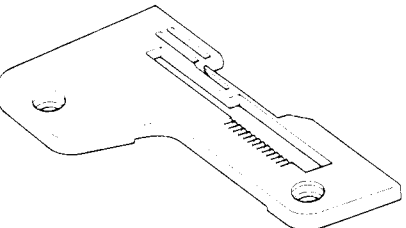
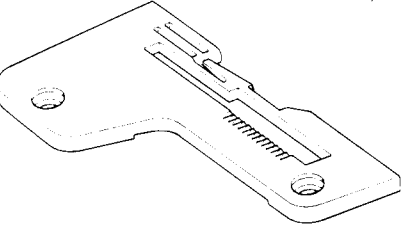
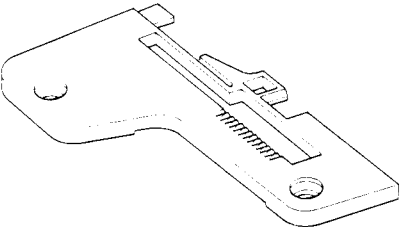
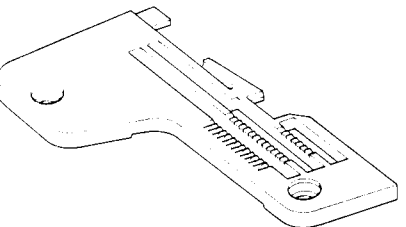
<p>202716-0-11</p> <p>3</p>  <p>527 00-1CD-02</p>	<p>202738-4-01</p> <p>3.5</p>  <p>527 00-1CD-02</p> <p>202302-0-10 744510-0-00</p>	<p>202783-0-11</p> <p>3.2</p>  <p>527 10-1CD-02 527 10-1CD-06</p>
<p>202876-0-11</p> <p>3</p>  <p>527 10-1CD 02</p>	<p>202877 0-11</p> <p>5</p>  <p>527 10-1CD-02</p>	<p>203014-0-12</p> <p>7</p>  <p>527 00-1CD-21</p>
<p>203035-0-11</p> <p>3.3</p>  <p>527 00-1CD-21</p>	<p>203037-0-12</p> <p>3.1</p>  <p>527 00-1CD 21</p>	<p>203047-0-21</p> <p>3</p>  <p>527 00-1CD-25</p>
<p>203048-0-21</p> <p>3.5</p>  <p>527 00-1CD-25</p>	<p>203072-0-11</p> <p>2</p>  <p>527 00-1CD-26</p>	<p>203148-0-11</p> <p>4.5</p>  <p>527 22-1CD-02 527 23-1CD-02</p>

744742-2-00 vite placca ago

needle plate screw

vis plaque aiguille

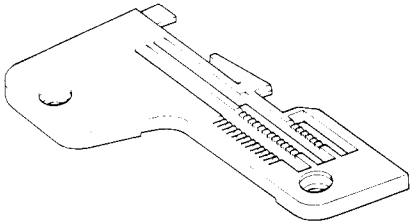
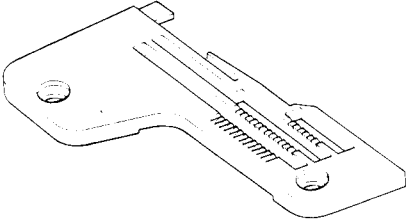
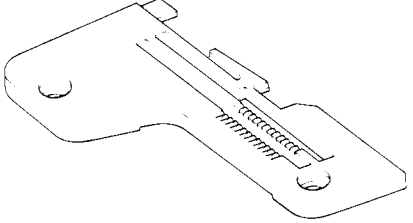
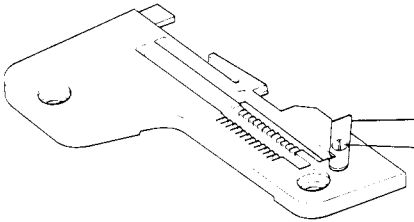
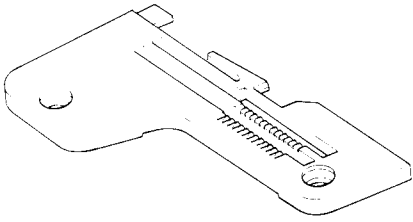
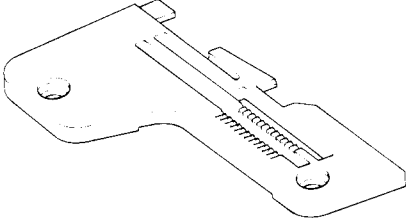
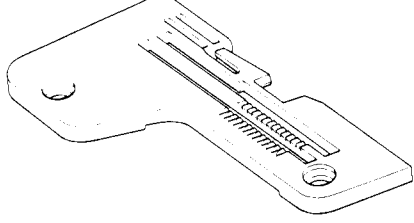
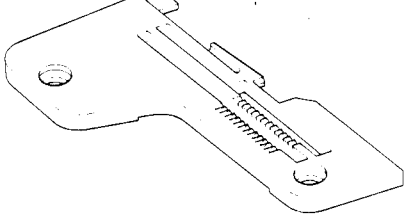
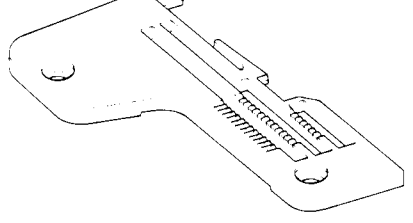
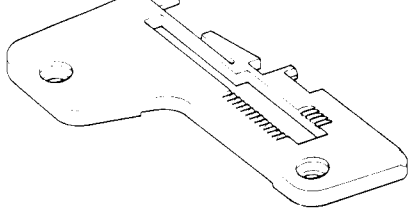
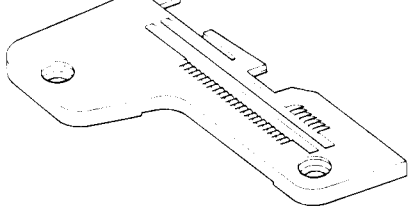
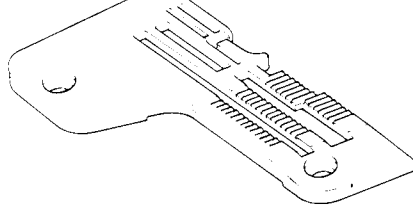
<p>203149-0-11</p>  <p>527-23-1CD-02</p>	<p>203150-0-10</p>  <p>527-22-1CD-03</p>	<p>203214-0-11</p>  <p>527-00-1CD-07 527-01-1CD-04 527-29-1CD-05 527-29-1CD-06</p>
<p>203216-4-11</p>  <p>527-00-1CD-07</p> <p>202302-0-10 744510-0-00</p>	<p>203217-0-11</p>  <p>527-00-1CD-07 527-01-1CD-04 527-29-1CD-05 527-29-1CD-06</p>	<p>203218-0-11</p>  <p>527-00-1CD-07 527-01-1CD-04 527-29-1CD-05 527-29-1CD-06</p>
<p>203219-0-11</p>  <p>527-00-1CD-07 527-00-1CD-31 527-01-1CD-05 527-01-1CD-09 527-30-1CD-07 527-38-1CD-01</p>	<p>203220-0-11</p>  <p>527-01-1CD-04 527-29-1CD-05 527-29-1CD-06</p>	<p>203280-0-11</p>  <p>527-22-1CD-04</p>
<p>203813-0-11</p>  <p>527-00-1CD-29</p>	<p>206297-0-01</p>  <p>527-10-1CD-02</p>	<p>207148-0-01</p>  <p>527-00-1CD-26</p>

744742-2-00

vite placca ago

needle plate screw

vis plaque aiguille

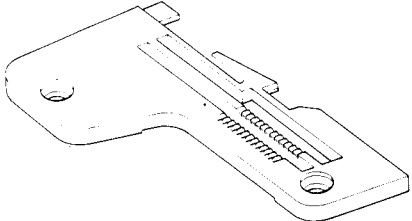
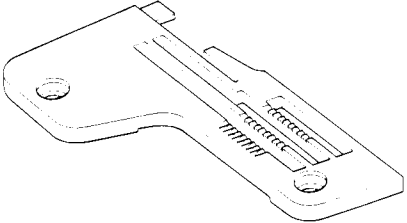
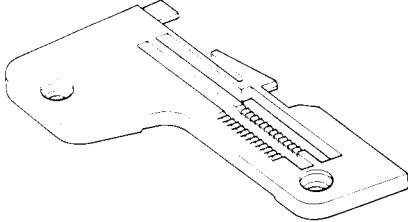
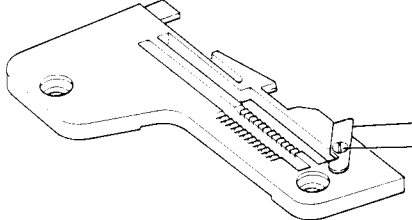
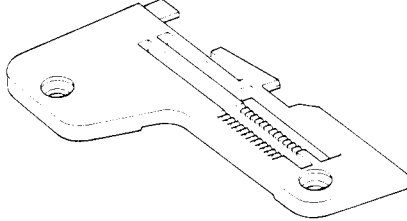
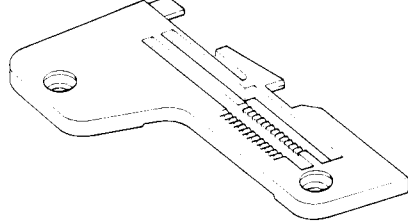
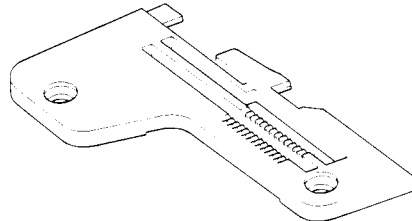
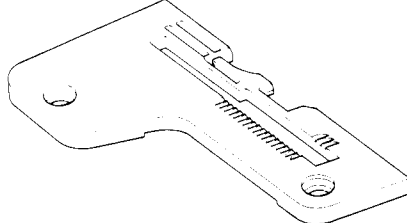
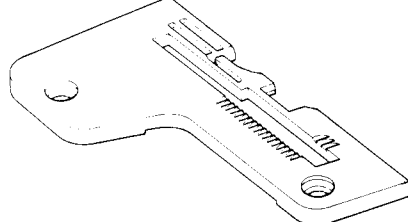
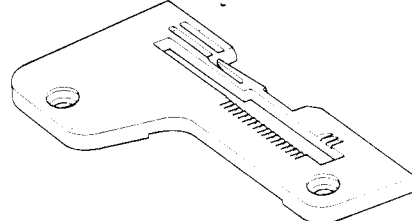
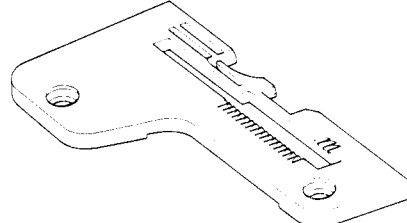
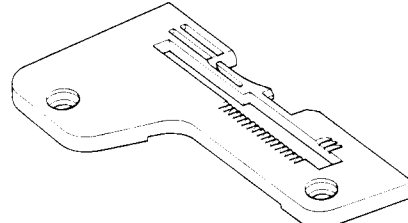
<p>202148-0-11</p> <p>4.6</p>  <p>527-00-1CD-01 527-00-1CD-20 527-01-1CD-01 527-01-1CD-02 527-28-1CD-02 527-29-1CD-01 527-29-1CD-02 527-34-1CD-01</p>	<p>202149-0-11</p> <p>5</p>  <p>527-16-1CD-01</p>	<p>202504-0-11</p> <p>4,1</p>  <p>527-00-1CD-01 527-00-1CD-20 527-01-1CD-01 527-01-1CD-02 527-28-1CD-02 527-29-1CD-01 527-29-1CD-02 527-34-1CD-01</p>
<p>202506-4-11</p> <p>4,1</p>  <p>527-00-1CD-01</p> <p>202302-0-10 744510-0-00</p>	<p>202507-0-11</p> <p>5</p>  <p>527-00-1CD-01 527-00-1CD-20 527-01-1CD-01 527-01-1CD-02 527-28-1CD-02 527-29-1CD-01 527-29-1CD-02 527-34-1CD-01</p>	<p>202508-0-11</p> <p>5,6</p>  <p>527-00-1CD-01 527-00-1CD-20 527-01-1CD-01 527-01-1CD-02 527-28-1CD-02 527-29-1CD-01 527-29-1CD-02 527-34-1CD-01</p>
<p>202590-0-11</p> <p>6</p>  <p>527-00-1CD-01 527-00-1CD-20 527-01-1CD-01 527-01-1CD-02 527-28-1CD-02 527-29-1CD-01 527-29-1CD-02 527-34-1CD-01</p>	<p>202634-0-11</p> <p>2,5</p>  <p>527-00-1CD-02</p>	<p>202635-0-11</p> <p>3,5</p>  <p>527-00-1CD-02</p>
<p>202636-0-11</p> <p>1,2</p>  <p>527-00-1CD-02 527-28-1CD-09</p>	<p>202707-0-11</p> <p>2</p>  <p>527-00-1CD-02</p>	<p>202709-0-11</p> <p>1,5</p>  <p>527-00-1CD-02</p>









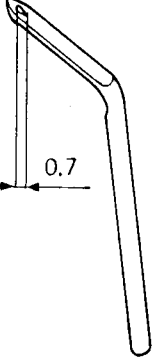
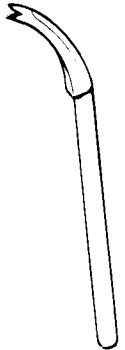
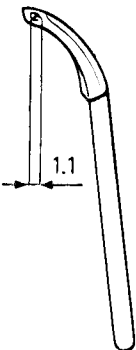
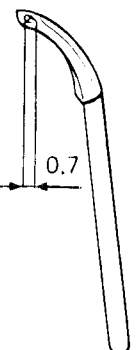
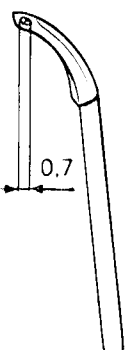
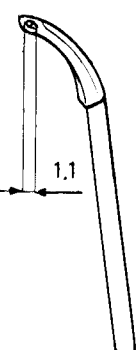
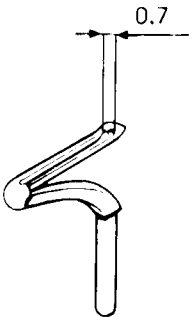
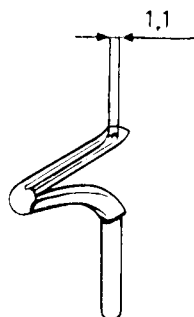

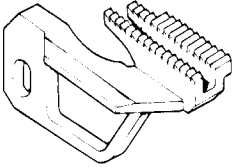

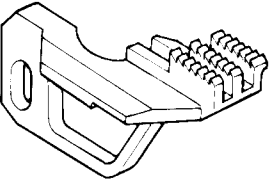
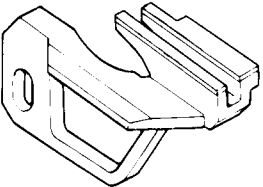

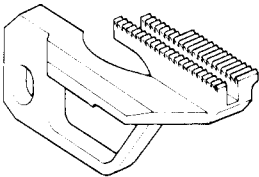

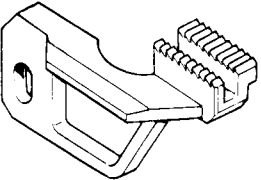

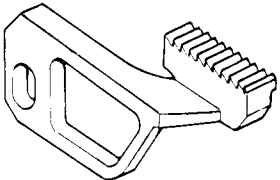

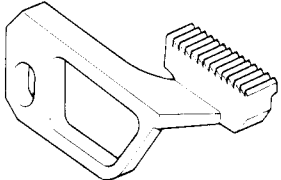

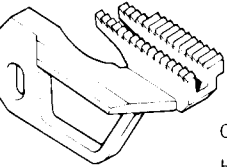

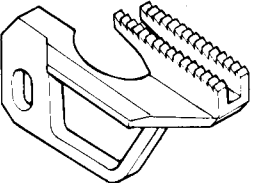
744742-2-00

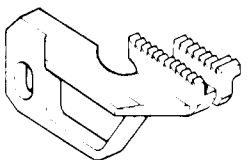

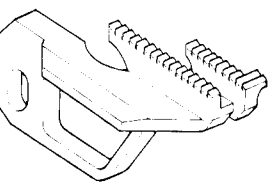
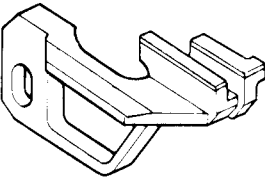

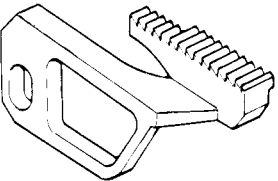
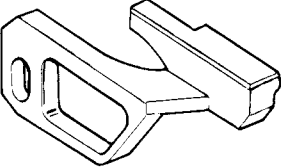

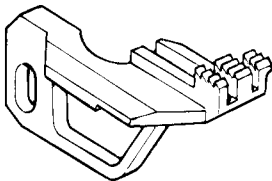

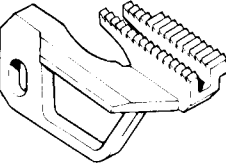
vite placca ago

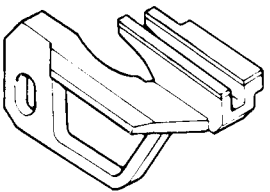
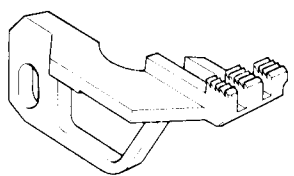

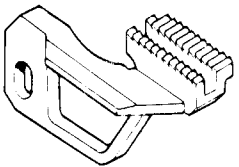

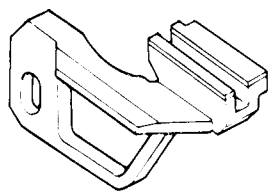
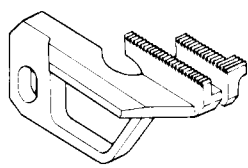

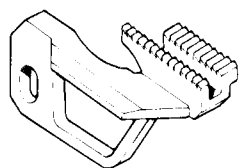



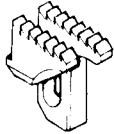

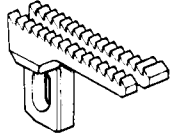
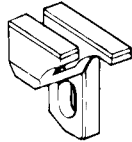

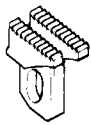

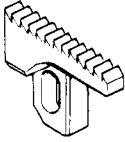

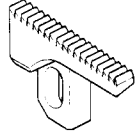

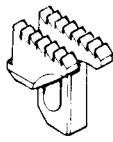

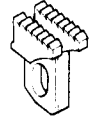

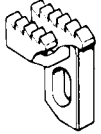
needle plate screw

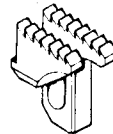
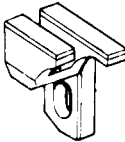

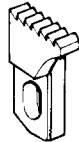
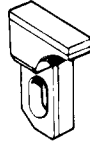

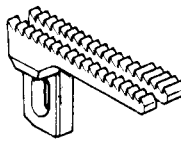

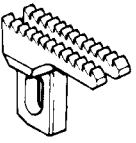

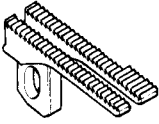

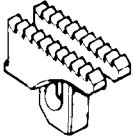
vis plaque aiguille

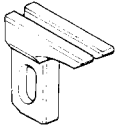
<p>202090-0-11</p>  <p>527-30-1CD-07</p>	<p>202092-0-11</p>  <p>527-00-1CD-01 527-10-1CD-02 527-10-1CD-06 527-28-1CD-02</p>	<p>204021-0-10</p>  <p>527-00-1CD-01 527-00-1CD-07 527-00-1CD-26 527-00-1CD-29 527-01-1CD-01 527-01-1CD-02 527-10-1CD-02 527-16-1CD-01 527-28-1CD-02 527-29-1CD-01 527-29-1CD-02 527-34-1CD-01</p>	<p>204033-0-10</p>  <p>527-00-1CD-01 527-00-1CD-02 527-00-1CD-07 527-00-1CD-21 527-00-1CD-25 527-00-1CD-26 527-00-1CD-29 527-00-1CD-31 527-01-1CD-04 527-01-1CD-05 527-01-1CD-09 527-10-1CD-02 527-10-1CD-06 527-22-1CD-02 527-22-1CD-03 527-22-1CD-04 527-23-1CD-02 527-28-1CD-02 527-28-1CD-09 527-29-1CD-05 527-29-1CD-06 527-38-1CD-01</p>	<p>206208-0-00</p>  <p>527-00-1CD-20</p>	<p>206209-0-00</p>  <p>527-00-1CD-20</p>
<p>202094-0-11</p>  <p>527-00-1CD-01 527-00-1CD-02 527-00-1CD-07 527-00-1CD-20 527-00-1CD-21 527-00-1CD-25 527-00-1CD-26 527-00-1CD-29 527-00-1CD-31 527-01-1CD-04 527-01-1CD-05 527-01-1CD-09 527-10-1CD-02 527-10-1CD-06 527-22-1CD-02 527-22-1CD-03 527-22-1CD-04 527-23-1CD-02 527-28-1CD-02 527-28-1CD-09 527-29-1CD-05 527-29-1CD-06 527-30-1CD-07 527-38-1CD-01</p>	<p>202095-0-11</p>  <p>527-00-1CD-01 527-00-1CD-07 527-00-1CD-20 527-00-1CD-26 527-00-1CD-29 527-01-1CD-01 527-01-1CD-02 527-10-1CD-02 527-16-1CD-01 527-28-1CD-02 527-29-1CD-01 527-29-1CD-02 527-34-1CD-01</p>				

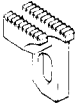
<p>202053-0-10</p>   <p>527-00-1CD-01 527-01-1CD-01 527-01-1CD-02 527-28-1CD-02 527-29-1CD-01 527-29-1CD-02</p>	<p>202054-0-10</p>   <p>527-16-1CD-01</p>	<p>202056-2-11</p>  <p>527-00-1CD-01 527-01-1CD-01 527-01-1CD-02 527-29-1CD-01 527-29-1CD-02</p>	<p>202517-0-00</p>   <p>527-00-1CD-01 527-00-1CD-07 527-01-1CD-01 527-01-1CD-02 527-28-1CD-02 527-29-1CD-01 527-29-1CD-02</p>
<p>202542-0-10</p>   <p>527-34-1CD-01</p>	<p>202605-0-10</p>   <p>527-00-1CD-02 527-28-1CD-09</p>	<p>202695-0-10</p>   <p>527-00-1CD-02 527-28-1CD-09</p>	<p>202757-0-00</p>   <p>527-00-1CD-01 527-28-1CD-02</p> <p>Cromatura dura Hard chromium plating Cromage dur</p>
<p>202780-0-10</p>   <p>527-10-1CD-02 527-10-1CD-06</p>	<p>203001-0-10</p>   <p>527-00-1CD-21</p>	<p>203028-0-10</p>   <p>527-00-1CD-21 527-00-1CD-26</p>	<p>203030-2-11</p>  <p>527-00-1CD-21</p>
<p>203060-0-10</p>   <p>527-00-1CD-25 527-00-1CD-26 527-00-1CD-29</p>	<p>203095-2-00</p>  <p>527-00-1CD-25 527-00-1CD-26 527-00-1CD-29</p>	<p>203140-0-10</p>   <p>527-22-1CD-02 527-22-1CD-03 527-23-1CD-02</p>	<p>203199-0-10</p>   <p>527-00-1CD-07 527-00-1CD-31 527-01-1CD-04 527-01-1CD-05 527-01-1CD-09 527-29-1CD-05 527-29-1CD-06 527-38-1CD-01</p>

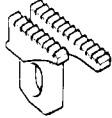
<p>203201-2-11</p>  <p>527-00-1CD-07 527-00-1CD-31 527-01-1CD-04 527-01-1CD-09 527-29-1CD-05 527-29-1CD-06</p>	<p>203270-0-10</p>  <p>1</p>  <p>527-22-1CD-04</p>	<p>205951-0-00</p>  <p>1,5</p>  <p>527-30-1CD-07</p>	<p>206293-2-00</p>  <p>527-30-1CD-07</p>
<p>207027-0-00</p>  <p>1</p>  <p>527-00-1CD-21</p>	<p>207077-0-00</p>  <p>1,5</p>  <p>527-00-1CD-20</p>		

<p>202057-0-10</p>   <p>527-00-1CD-01 527-00-1CD-07 527-00-1CD-31 527-01-1CD-01 527-01-1CD-02 527-01-1CD-04 527-01-1CD-05 527-01-1CD-09 527-28-1CD-02 527-29-1CD-01 527-29-1CD-02 527-29-1CD-05 527-29-1CD-06 527-38-1CD-01</p>	<p>202058-0-11</p>   <p>527-16-1CD-01</p>	<p>202060-2-11</p>  <p>527-00-1CD-01 527-00-1CD-07 527-00-1CD-31 527-01-1CD-01 527-01-1CD-02 527-01-1CD-04 527-01-1CD-09 527-29-1CD-01 527-29-1CD-02 527-29-1CD-05 527-29-1CD-06</p>	<p>202559-0-00</p>   <p>527-00-1CD-01 527-00-1CD-07 527-01-1CD-01 527-01-1CD-02 527-28-1CD-02 527-29-1CD-01 527-29-1CD-02</p>
<p>202608-0-10</p>   <p>527-00-1CD-02 527-28-1CD-09</p>	<p>202699-0-10</p>   <p>527-00-1CD-02 527-28-1CD-09</p>	<p>202758-0-00</p>   <p>527-00-1CD-01 527-28-1CD-02</p> <p>Cromatura dura Hard chromium plating Cromage dur</p>	<p>202782-0-10</p>   <p>527-10-1CD-02 527-10-1CD-06</p>
<p>203002-0-10</p>   <p>527-00-1CD-21</p>	<p>203031-0-10</p>   <p>527-00-1CD-21 527-00-1CD-26</p>	<p>203033-2-11</p>  <p>527-00-1CD-21</p>	<p>203062-0-10</p>   <p>527-00-1CD-25 527-00-1CD-26 527-00-1CD-29</p>
<p>203094-2-00</p>  <p>527-00-1CD-25 527-00-1CD-26 527-00-1CD-29</p>	<p>203141-0-10</p>   <p>527-22-1CD-02 527-22-1CD-03 527-23-1CD-02</p>	<p>203265-0-11</p>   <p>527-34-1CD-01</p>	<p>203271-0-11</p>   <p>527-22-1CD-04</p>

<p>205952-0-00</p>  <p>527-30-1CD-07</p> 	<p>206295-2-01</p>  <p>527-30-1CD-07</p> 	<p>207028-0-00</p>  <p>527-00-1CD-21</p> 	<p>207079-0-00</p>  <p>527-00-1CD-20</p> 
<p>202061-0-10</p>  <p>527-00-1CD-01 527-00-1CD-07 527-00-1CD-20 527-00-1CD-26 527-00-1CD-29 527-01-1CD-01 527-01-1CD-02 527-01-1CD-04 527-10-1CD-02 527-10-1CD-06 527-16-1CD-01 527-22-1CD-02 527-22-1CD-03 527-22-1CD-04 527-23-1CD-02 527-28-1CD-02 527-29-1CD-01 527-29-1CD-02 527-29-1CD-05 527-29-1CD-06 527-34-1CD-01</p>	<p>202609-0-10</p>  <p>527-00-1CD-02 527-00-1CD-25 527-00-1CD-31 527-01-1CD-05 527-01-1CD-09 527-28-1CD-09 527-30-1CD-07 527-38-1CD-01</p>	<p>203004-0-10</p>  <p>527-00-1CD-21 527-00-1CD-26</p>	



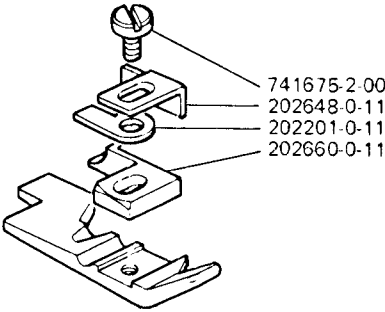
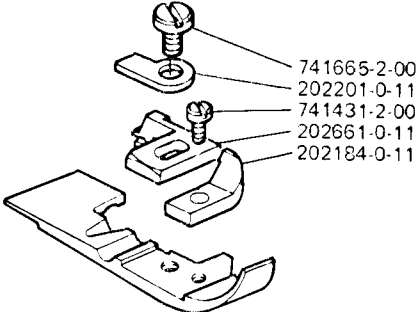
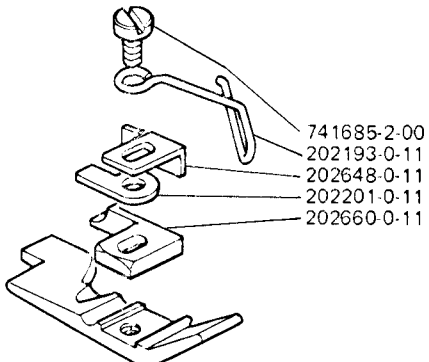
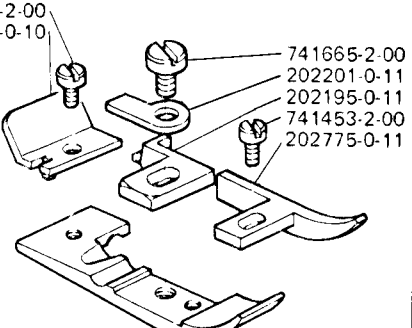
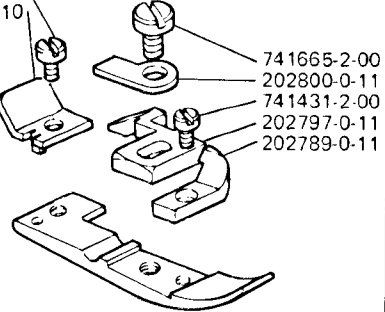
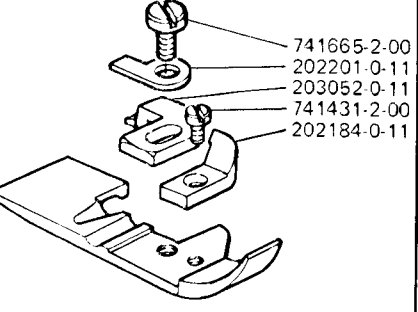
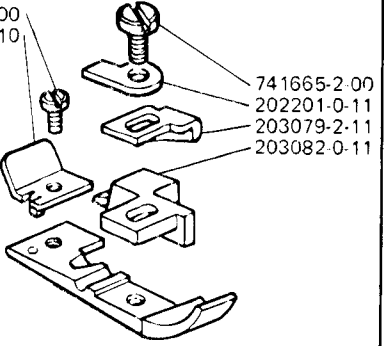
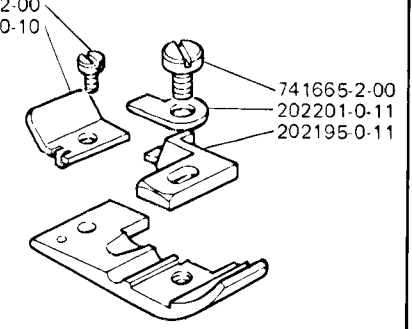

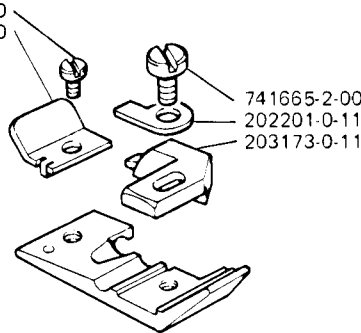
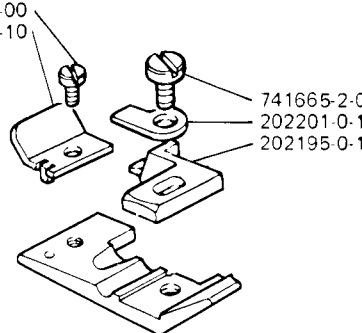
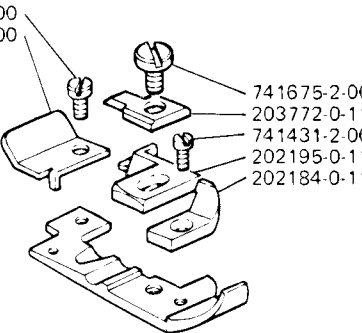
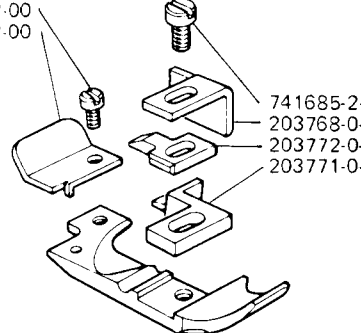
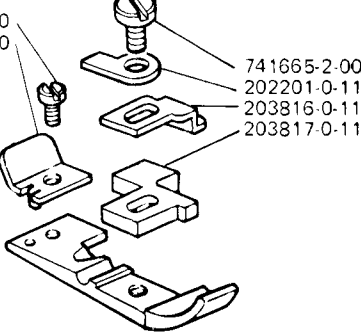
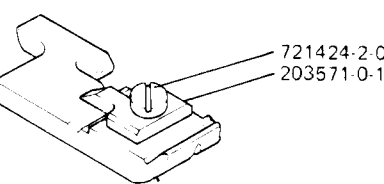
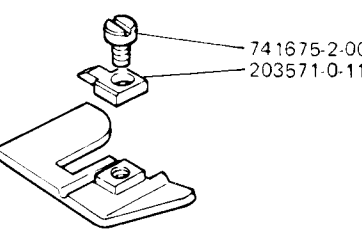
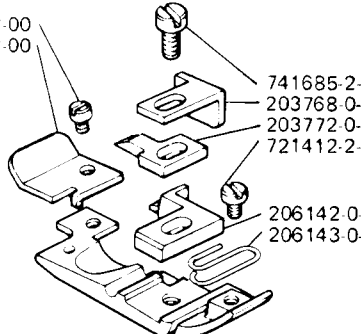
<p style="text-align: center;">202171-3-11</p> <p>527-00-1CD-01 527-00-1CD-07 527-00-1CD-20</p> <p>Assemblaggi tessuti medi Medium weight fabrics assembly Assemblages tissus moyens</p>	<p style="text-align: center;">202172-3-11</p> <p>527-00-1CD-01 527-00-1CD-07 527-01-1CD-01</p> <p>Teflon</p> <p>Assemblaggi tessuti scivolosi Slippery fabrics assembly Assemblages tissus glissants</p>	<p style="text-align: center;">202173-3-11</p> <p>527-00-1CD-01 527-00-1CD-07</p> <p>Assemblaggi tessuti medi, leggeri per evitare il risvolto del tessuto Medium and light weight fabric assembly to avoid fabric turning Assemblages tissus moyens, legers pour éviter le repli du tissu</p>	<p style="text-align: center;">202175-3-11</p> <p>527-29-1CD-01 527-29-1CD-05</p> <p>Surfilatura con inserimento di elastico Ø 1 mm For serging operation with insertion of elastic Ø 1 mm Surfilage avec insertion d'élastique Ø 1 mm</p>
<p style="text-align: center;">202176-3-11</p> <p>527-29-1CD-02 527-29-1CD-06</p> <p>Surfilatura con inserimento di elastico piatto max 4 mm For serging operation with insertion of flat elastic mm 4 max width Surfilage avec insertion d'élastique plat max 4 mm</p>	<p style="text-align: center;">202177-3-11</p> <p>527-16-1CD-01</p> <p>Bordatura con para sgambatura slip For edging the leg openings of slippers inserting a rubber strip Pose laminière enjambure slip</p>	<p style="text-align: center;">202178-3-11</p> <p>527-01-1CD-02 527-01-1CD-04 527-01-1CD-05</p> <p>Assemblaggi con tessuto di rinforzo Assembly with reinforcing fabrics Assemblages avec tissu de renfort</p>	<p style="text-align: center;">202509-3-11</p> <p>527-00-1CD-01 527-00-1CD-07 527-01-1CD-01</p> <p>Assemblaggi tessuti medi e leggeri Medium and light weight fabrics assembly Assemblages tissus moyens et legers</p>

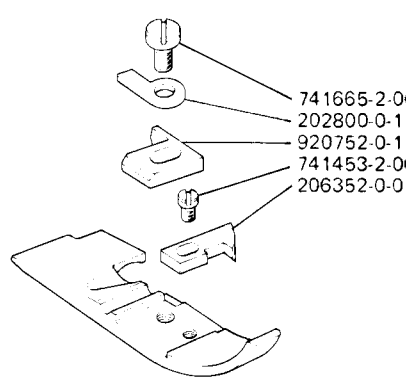
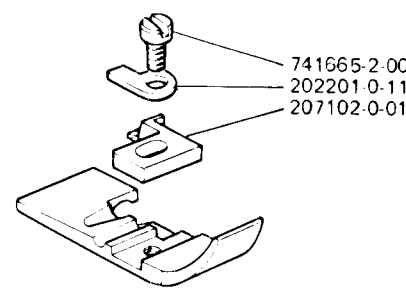
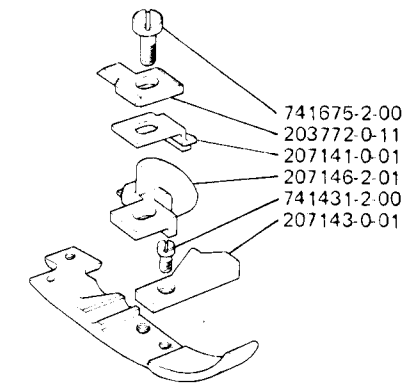
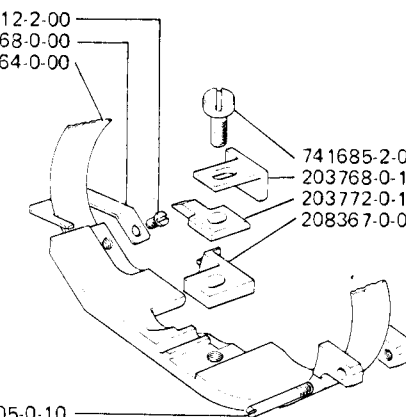
<p>202642-3-11</p> <p>527-00-1CD-02</p>  <p>741675-2-00 202648-0-11 202201-0-11 202660-0-11</p> <p>Assemblaggi tessuti indemagliabili Warp knit fabrics assembly Assemblages tissus indémaillables</p>	<p>202643-3-11</p> <p>527-28-1CD-09</p>  <p>741665-2-00 202201-0-11 741431-2-00 202661-0-11 202184-0-11</p> <p>Surfilatura tovaglie e tovaglioli For serging operation of table cloths and table napkins Surfilage nappes et serviettes</p>	<p>202732-3-01</p> <p>527-00-1CD-02</p>  <p>741685-2-00 202193-0-11 202648-0-11 202201-0-11 202660-0-11</p> <p>Assemblaggi tessuti indemagliabili per evitare il risvolto del tessuto Warp knit assembly to avoid fabric turning Assemblages tissus indémaillable pour éviter le repli du tissu</p>	<p>202774-3-11</p> <p>527-28-1CD-02</p>  <p>741413-2-00 202192-0-10 741665-2-00 202201-0-11 202195-0-11 741453-2-00 202775-0-11</p> <p>Surfilatura in genere For serging operation in generally Surfilage en général</p>
<p>202786-3-11</p> <p>527-10-1CD-02 527-10-1CD-06</p>  <p>741413-2-00 202795-0-10 741665-2-00 202800-0-11 741431-2-00 202797-0-11 202789-0-11</p> <p>Orature punto invisibile su maglieria media e leggera in genere For blind stitch edging of medium and light knit fabrics Ourlets point invisible pour bonneterie moyenne et légère</p>	<p>203050-3-11</p> <p>527-00-1CD-25</p>  <p>741665-2-00 202201-0-11 203052-0-11 741431-2-00 202184-0-11</p> <p>Assemblaggi di tessuti sfilacciabili Assembly of fabrics which fray Assemblages de tissus qui s'effilochent</p>	<p>203077-3-11</p> <p>527-00-1CD-26</p>  <p>741413-2-00 202795-0-10 741665-2-00 202201-0-11 203079-2-11 203082-0-11</p> <p>Per tessuti tipo flanella con bordi sfilacciabili For type flannel fabrics with fraying hems Pour tissus type flanelle avec bords qui s'effilochent</p>	<p>203157-3-11</p> <p>527-01-1CD-01 527-22-1CD-02 527-22-1CD-04</p>  <p>741413-2-00 202192-0-10 741665-2-00 202201-0-11 202195-0-11</p> <p>Per tessuti in trama-ordito leggeri e leggerissimi non sfilacciabili For non-frayed weft and warp light and very light fabrics Pour tissus chaîne et trame légers et très légers qui ne s'effilochent pas</p>

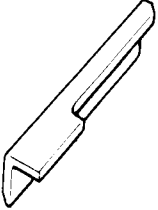
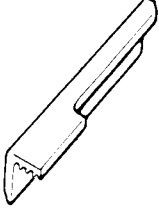
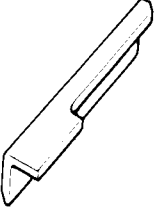
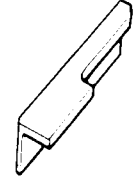
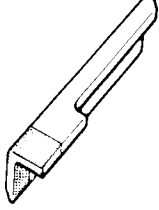
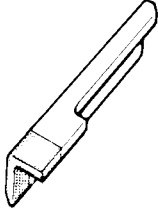
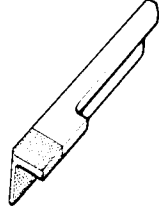
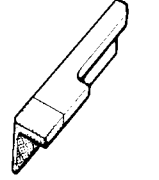
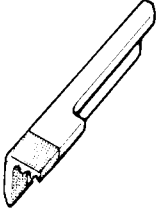
<p>203159-3-11</p> <p>527-22-1CD-03</p>  <p>741413-2-00 202192-0-10</p> <p>741665-2-00 202201-0-11 203173-0-11</p> <p>Assemblaggi con arricciatura di tessuti trama-ordito leggeri sfilacciabili Assembly with gathering of weft and warp light fabrics which fray Assemblages avec fronçage de tissus chaîne et trame légers qui s'effilochent</p>	<p>203160-3-11</p> <p>527-23-1CD-02</p>  <p>741413-2-00 202192-0-10</p> <p>741665-2-00 202201-0-11 202195-0-11</p> <p>Per tessuti trama-ordito medio con inserimento di fettuccia e cordoncino For weft and warp medium weight fabrics with insertion of tape and string Pour tissus chaîne et trame moyens avec insertion d'extra fort et cordon</p>	<p>203162-3-11</p> <p>527-00-1CD-31 527-38-1CD-01</p>  <p>741413-2-00 203025-2-00</p> <p>741675-2-00 203772-0-11 741431-2-00 202195-0-11 202184-0-11</p> <p>Assemblaggi tessuti leggeri in genere applicazione di profili Light weight fabrics assembly in general application of decorative piping Assemblages tissus légers en général pose passepoils</p>	<p>203765-3-11</p> <p>527-22-1CD-02</p>  <p>741413-2-00 203025-2-00</p> <p>741685-2-00 203768-0-11 203772-0-11 203771-0-11</p> <p>Assemblaggi senza arricciatura Assembly without gathering Assemblages sans fronçage</p>
<p>203815-3-11</p> <p>527-00-1CD-29</p>  <p>741413-2-00 202795-0-10</p> <p>741665-2-00 202201-0-11 203816-0-11 203817-0-11</p> <p>Per tessuti tipo spugna For type sponge fabrics Pour tissus type éponge</p>	<p>205892-3-00</p> <p>527-01-1CD-09</p>  <p>721424-2-00 203571-0-11</p> <p>Assemblaggi con profilo Assembly with decorative piping Assemblages avec passepoil</p>	<p>205954-3-01</p> <p>527-30-1CD-07</p>  <p>741675-2-00 203571-0-11</p> <p>Applicazione pizzi rigidi Applications of rigid lace Pour poser de dentelles rigides</p>	<p>206140-3-02</p> <p>527-34-1CD-01</p>  <p>741413-2-00 203025-2-00</p> <p>741685-2-00 203768-0-11 203772-0-11 721412-2-00</p> <p>206142-0-01 206143-0-00</p> <p>Applicazione di elastici su tessuti medi e leggeri Application of elastics on medium and light weight fabrics Pour poser des elastiques sur tissus moyens et légers</p>

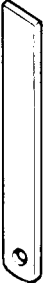
<p>206350-3-00</p> <p>527-10-1CD-06</p>  <p>741665-2-00 202800-0-11 920752-0-11 741453-2-00 206352-0-01</p> <p>Assemblaggi, senza orlatura, di tessuti medi e leggeri Assembly, without hemming, of medium and light weight fabrics Assemblages, sans ourler, de tissus moyens et legers</p>	<p>207100-3-01</p> <p>527-00-1CD-25</p>  <p>741665-2-00 202201-0-11 207102-0-01</p> <p>Assemblaggio teli ombrelli Umbrella panels assembly Assemblages toiles de parapluies</p>	<p>207147-3-01</p> <p>527-00-1CD-26</p>  <p>741675-2-00 203772-0-11 207141-0-01 207146-2-01 741431-2-00 207143-0-01</p> <p>Surfilatura di strofinacci leggeri Serging of light floor-cloths Surfilage de serpilleres legeres</p>	<p>208365-3-00</p> <p>527-00-1CD-21</p>  <p>721412-2-00 208368-0-00 208364-0-00 741685-2-00 203768-0-11 203772-0-11 208367-0-00 303805-0-10</p> <p>Assemblaggi tessuti scivolosi Slippery fabrics assembly Assemblages tissus glissants</p>
---	---	---	--

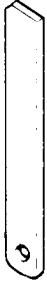
<p>202142-0-10</p>  <p>527-00-1CD-01 527-00-1CD-02 527-00-1CD-07 527-00-1CD-20 527-00-1CD-31 527-01-1CD-01 527-01-1CD-02 527-01-1CD-04 527-01-1CD-05 527-01-1CD-09 527-10-1CD-02 527-10-1CD-06 527-22-1CD-02 527-22-1CD-03 527-22-1CD-04 527-23-1CD-02 527-28-1CD-02 527-28-1CD-09 527-30-1CD-07 527-34-1CD-01</p>	<p>202143-0-10</p>  <p>527-00-1CD-01 527-00-1CD-02 527-00-1CD-07 527-00-1CD-20 527-00-1CD-31 527-01-1CD-01 527-01-1CD-02 527-01-1CD-04 527-01-1CD-05 527-01-1CD-09 527-10-1CD-02 527-10-1CD-06 527-22-1CD-02 527-22-1CD-03 527-22-1CD-04 527-23-1CD-02 527-28-1CD-02 527-28-1CD-09 527-30-1CD-07</p>	<p>203066-0-10</p>  <p>527-00-1CD-25 527-00-1CD-26 527-29-1CD-01 527-29-1CD-02 527-29-1CD-05 527-29-1CD-06</p>	<p>203812-0-10</p>  <p>527-00-1CD-29</p>	<p>207000-2-00</p>  <p>527-00-1CD-01 527-00-1CD-02 527-00-1CD-07 527-00-1CD-31 527-01-1CD-01 527-01-1CD-02 527-01-1CD-04 527-01-1CD-05 527-01-1CD-09 527-10-1CD-02 527-10-1CD-06 527-22-1CD-02 527-22-1CD-03 527-22-1CD-04 527-23-1CD-02 527-28-1CD-02 527-28-1CD-09 527-30-1CD-07 527-34-1CD-01 527-38-1CD-01</p> <p>con placchetta in lega dura with hard alloyed plate avec plaquette en alliage dur</p>
<p>207001-2-00</p>  <p>527-00-1CD-21</p> <p>con placchetta in lega dura with hard alloyed plate avec plaquette en alliage dur</p>	<p>207006-2-00</p>  <p>527-00-1CD-21 527-00-1CD-25 527-00-1CD-26 527-29-1CD-01 527-29-1CD-02 527-29-1CD-05 527-29-1CD-06</p> <p>con placchetta in lega dura with hard alloyed plate avec plaquette en alliage dur</p>	<p>207007-2-00</p>  <p>527-00-1CD-29</p> <p>con placchetta in lega dura with hard alloyed plate avec plaquette en alliage dur</p>	<p>207008-2-00</p>  <p>527-00-1CD-01 527-00-1CD-02 527-00-1CD-07 527-00-1CD-31 527-01-1CD-01 527-01-1CD-02 527-01-1CD-04 527-01-1CD-05 527-01-1CD-09 527-10-1CD-02 527-10-1CD-06 527-22-1CD-02 527-22-1CD-03 527-22-1CD-04 527-23-1CD-02 527-28-1CD-02 527-28-1CD-09 527-30-1CD-07 527-34-1CD-01</p> <p>con placchetta in lega dura with hard alloyed plate avec plaquette en alliage dur</p>	

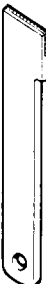
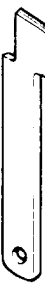
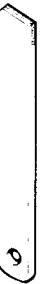
<p>202146-0-10</p>  <p>527-00-1CD-01 527-00-1CD-02 527-00-1CD-07 527-00-1CD-20 527-00-1CD-31 527-01-1CD-01 527-01-1CD-02 527-01-1CD-04 527-01-1CD-05 527-01-1CD-09 527-10-1CD-02 527-10-1CD-06 527-22-1CD-02 527-22-1CD-04 527-23-1CD-02 527-28-1CD-02 527-28-1CD-09 527-29-1CD-01 527-29-1CD-02 527-29-1CD-05 527-29-1CD-06 527-30-1CD-07 527-34-1CD-01</p>	<p>203012-0-10</p>  <p>527-00-1CD-21</p>	<p>203069-0-10</p>  <p>527-00-1CD-26 527-00-1CD-29</p>	<p>203144-0-10</p>  <p>527-00-1CD-25 527-22-1CD-03</p>	<p>207015-2-00</p>  <p>527-00-1CD-01 527-00-1CD-02 527-00-1CD-07 527-00-1CD-31 527-01-1CD-01 527-01-1CD-02 527-01-1CD-04 527-01-1CD-05 527-01-1CD-09 527-10-1CD-02 527-10-1CD-06 527-22-1CD-02 527-22-1CD-04 527-23-1CD-02 527-28-1CD-02 527-28-1CD-09 527-29-1CD-01 527-29-1CD-02 527-29-1CD-05 527-29-1CD-06 527-30-1CD-07 527-34-1CD-01 527-38-1CD-01</p> <p>con placchetta in lega dura with hard alloyed plate avec plaquette en alliage dur</p>
<p>207016-2-00</p>  <p>527-00-1CD-21</p> <p>con placchetta in lega dura with hard alloyed plate avec plaquette en alliage dur</p>	<p>207017-2-00</p>  <p>527-00-1CD-21 527-00-1CD-26 527-00-1CD-29</p> <p>con placchetta in lega dura with hard alloyed plate avec plaquette en alliage dur</p>	<p>207024-2-00</p>  <p>527-00-1CD-25 527-22-1CD-03</p> <p>con placchetta in lega dura with hard alloyed plate avec plaquette en alliage dur</p>		

GUIDE E PORTA ROTOLI			GUIDES AND ROLL CARRIERS				GUIDES ET PORTE ROULEAUX		
R = A RICHIESTA			ON REQUEST				SUR DEMANDE		
TESTA HEAD TETE	GUIDA GUIDE GUIDE	SUPPORTO SUPPORT SUPPORT	BLOCCHETTO BLOCK BLOC	PIASTRINA PLATE PLAQUETTE	SQUADRETTA BRACKET EQUERRE	PIEGHETTATORE FOLDING DEVICE PLISSEUR	LEVA LEVER LEVIER	GINOCCHIELLO KNEE-PRESS GENOUILLERE	PORTA ROTOLO ROLL CARRIER PORTE-ROULEAU
527-00-1CD-01	202300-0-10 202767-4-10	R R							
527-00-1CD-02									
527-00-1CD-07	202300-0-10 202767-4-10	R R							
527-00-1CD-20									
527-00-1CD-21									
527-00-1CD-25									
527-00-1CD-26									
527-00-1CD-29									
527-00-1CD-31	202300-0-10 202767-4-10	R R							
527-01-1CD-01	201311-2-10		203223-4-10	203239-4-10	202303-0-10	203193-2-10			991589-4-00
527-01-1CD-02	991225-4-00								991228-4-10
527-01-1CD-04	991225-4-00								991228-4-10
527-01-1CD-05	991225-4-00								991228-4-10
527-01-1CD-09	205890-2-00 202300-0-10 202767-4-10	R R	203223-4-10	203239-4-10	202303-0-10	203193-2-10			
527-10-1CD-02	202851-4-11								
527-10-1CD-06	203711-4-11		203708-4-11						

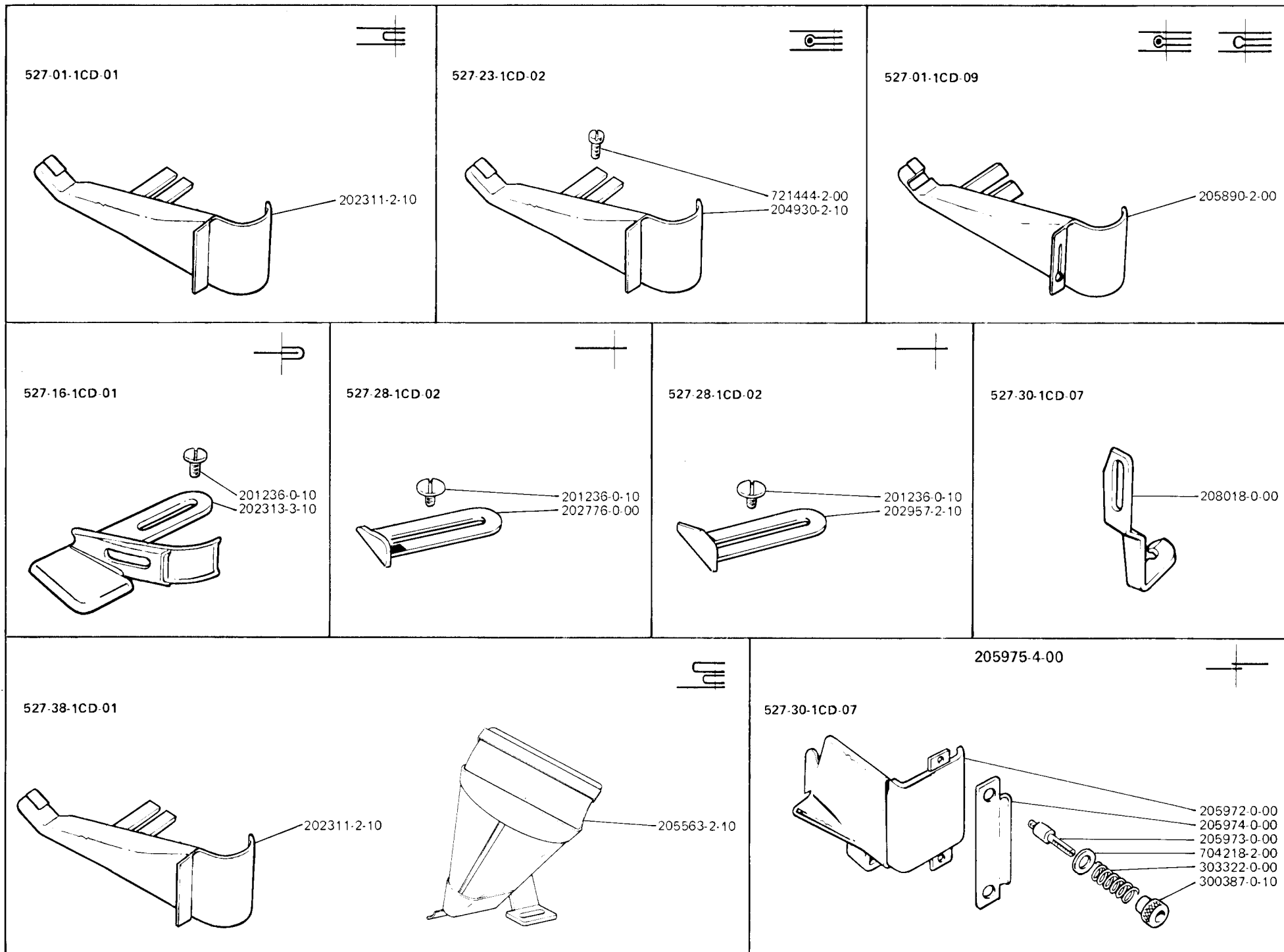

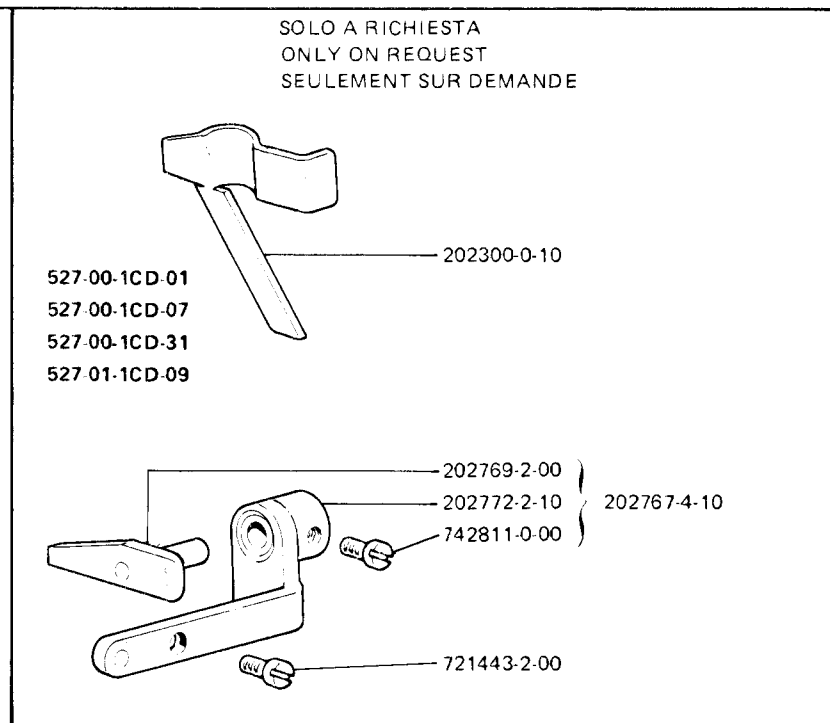
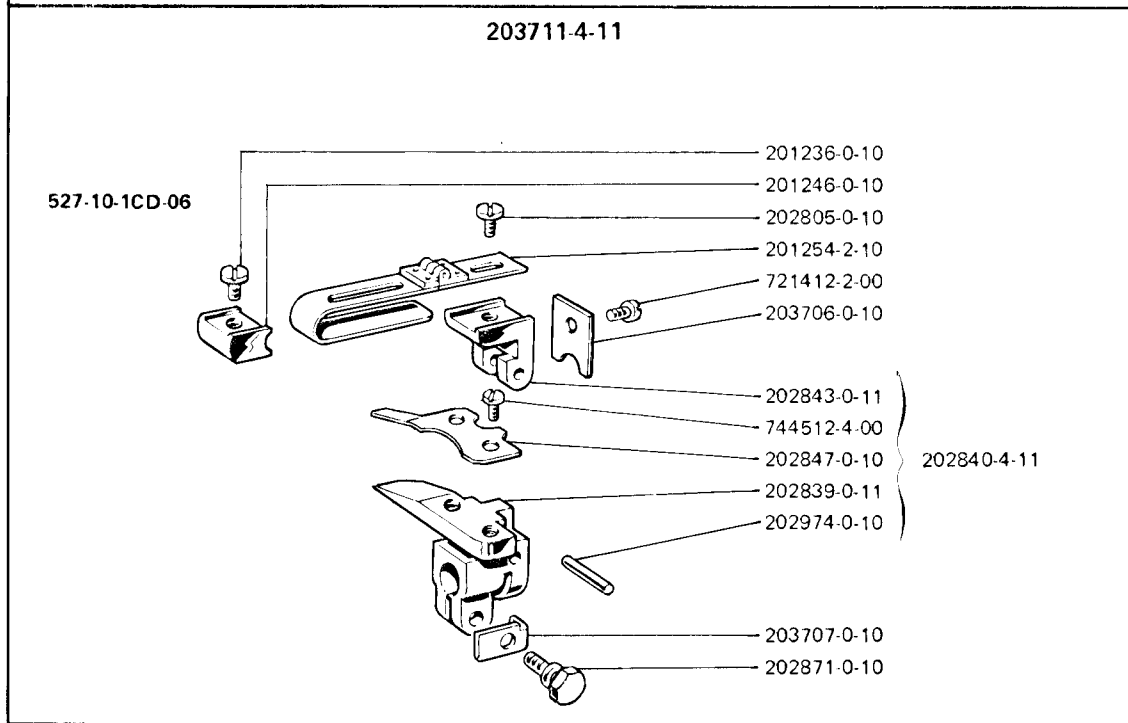
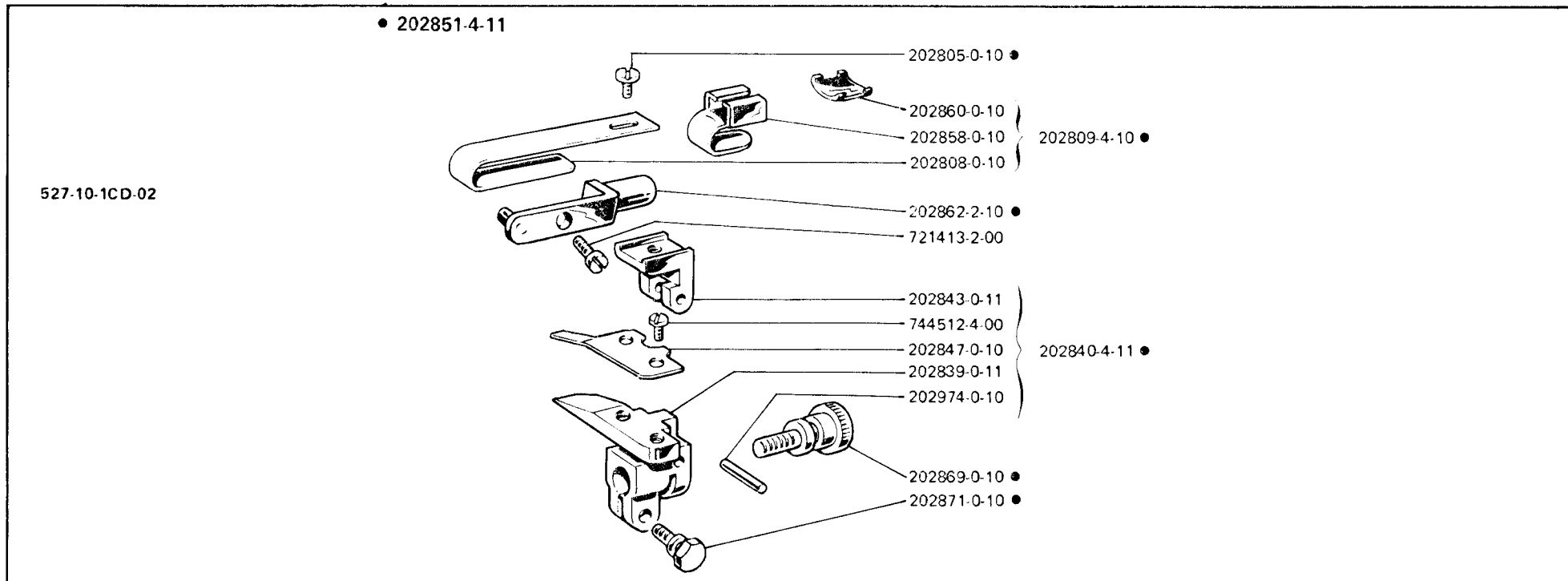

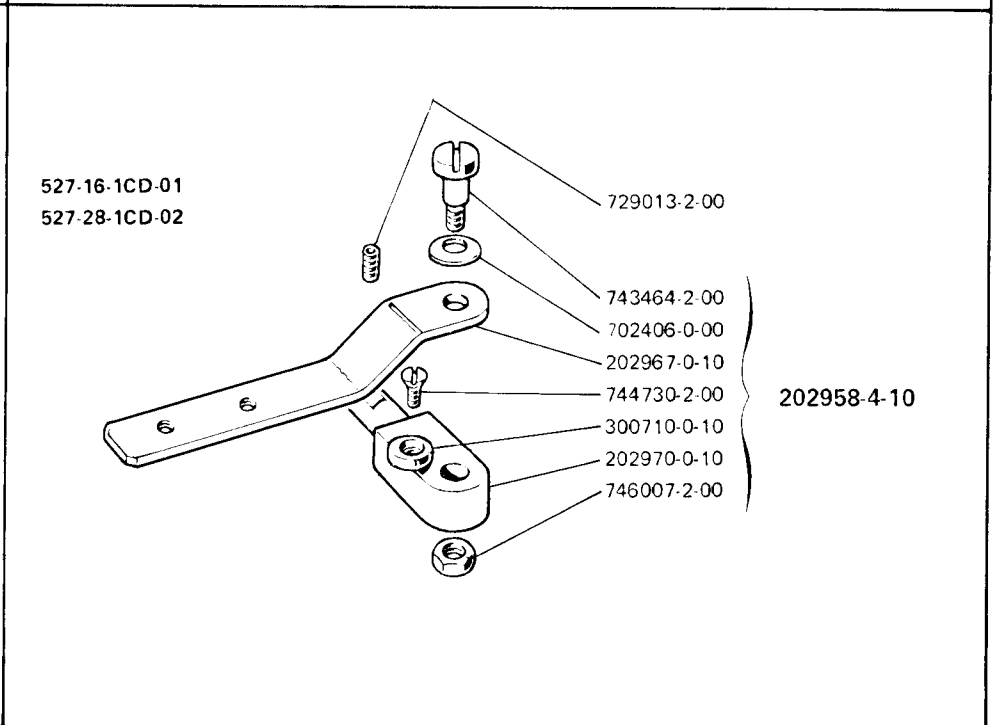
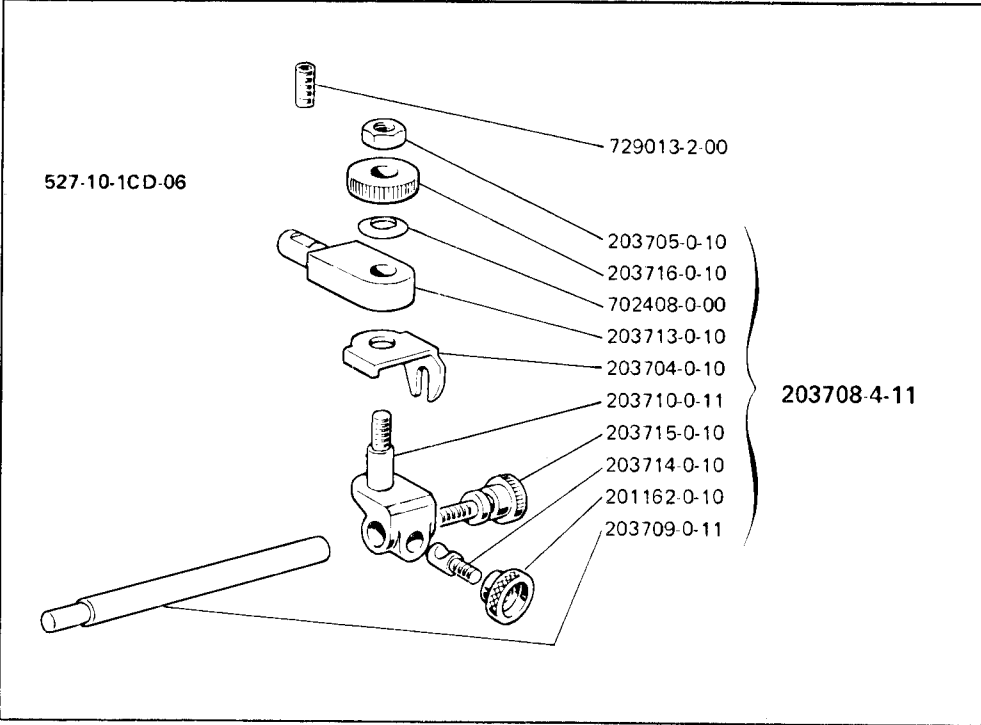
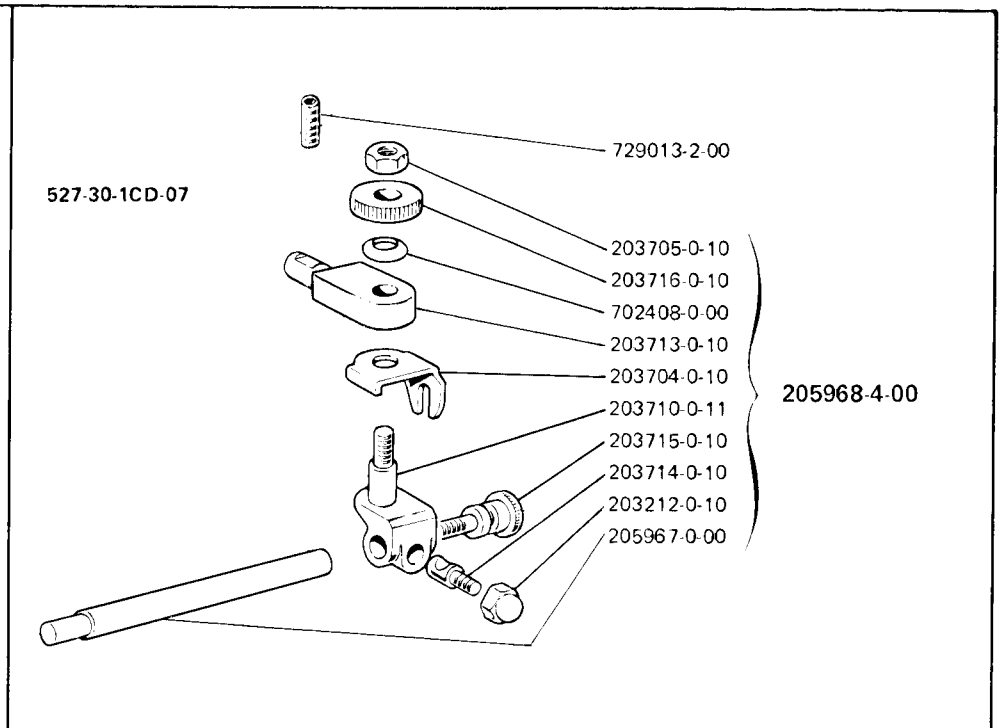
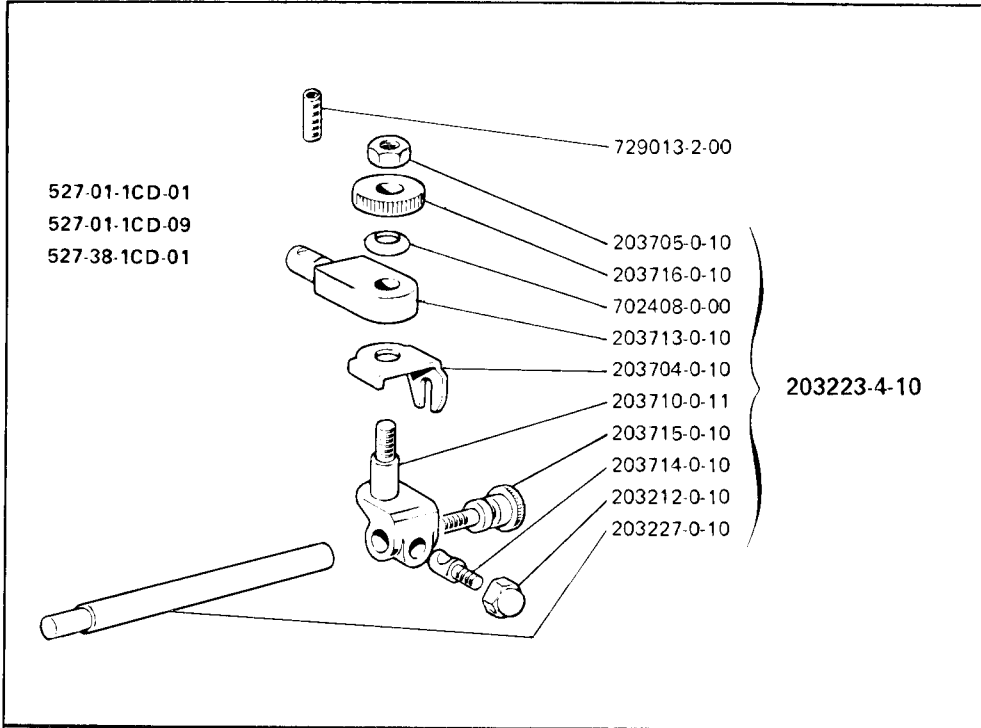

- 527-01-1CD-01
- 527-01-1CD-09
- 527-22-1CD-02
- 527-22-1CD-03
- 527-22-1CD-04
- 527-23-1CD-02
- 527-30-1CD-07
- 527-38-1CD-01

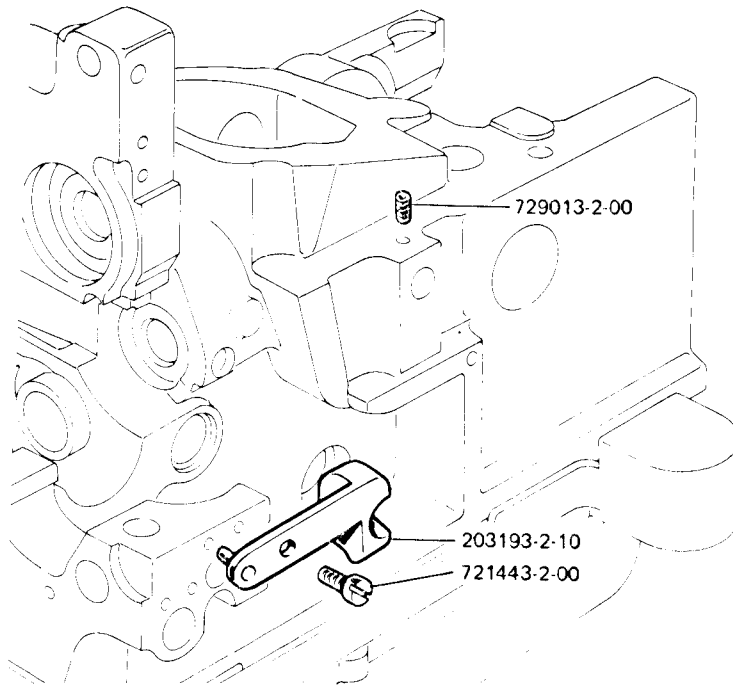

- 527-01-1CD-01
- 527-01-1CD-09

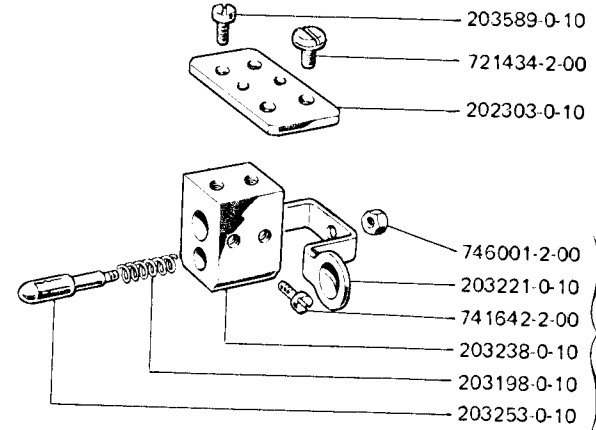

203239-4-10

- 527-38-1CD-01

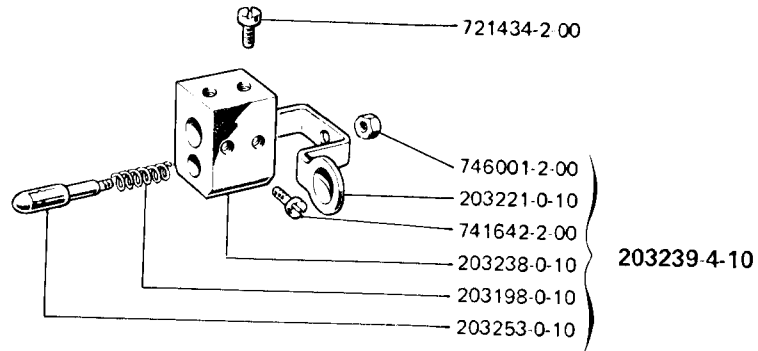

203239-4-10

- 527-30-1CD-07

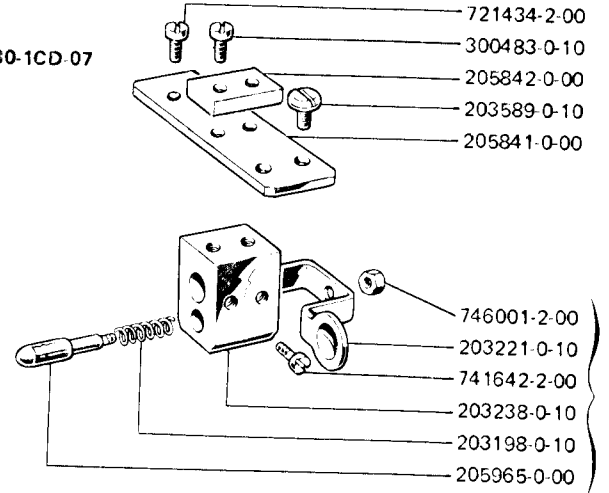

205966-4-00

● 204915-4-13

- 527 22-1CD-02
- 527 22-1CD-03
- 527 22-1CD-04
- 527 23-1CD-02

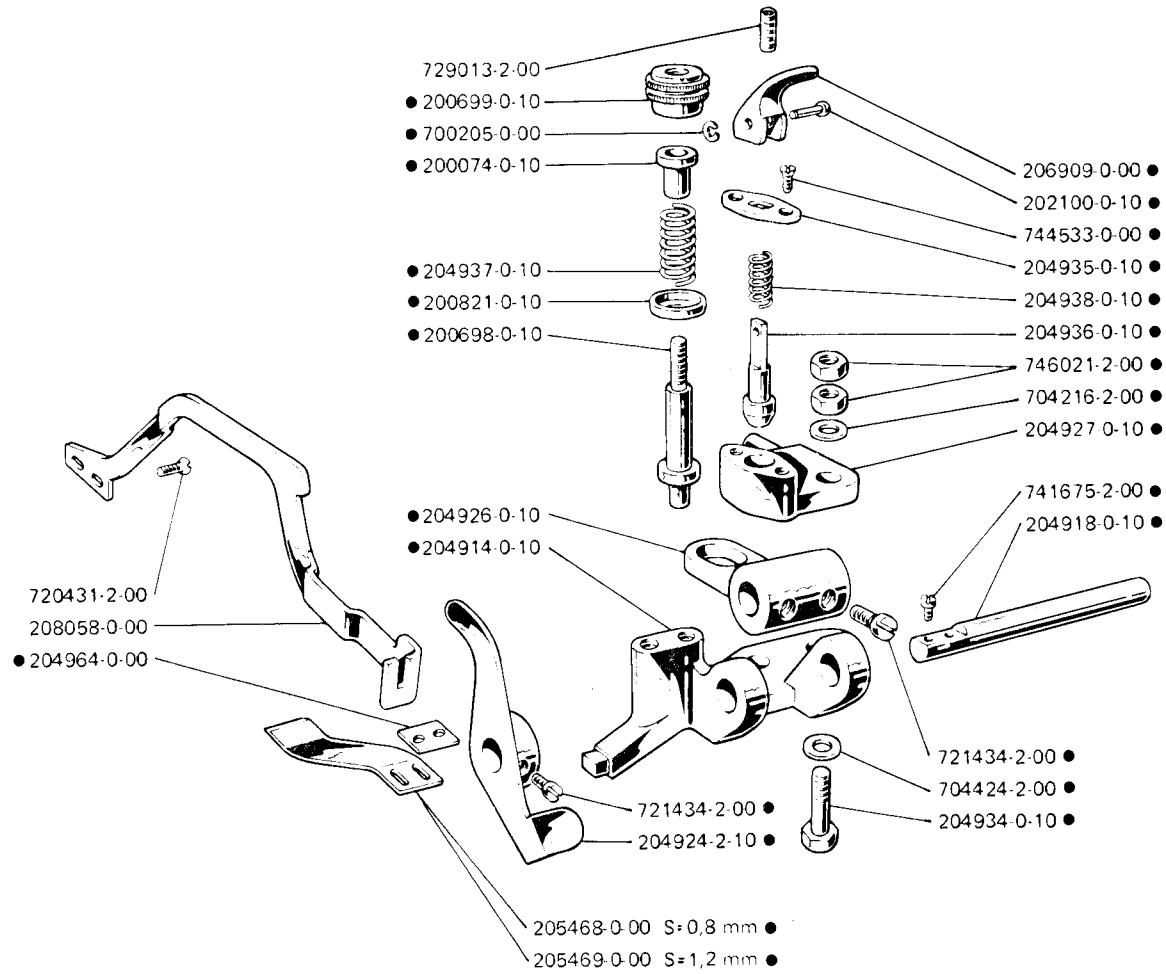

920245-4-02

- 527-22-1CD-02
- 527-22-1CD-03
- 527-22-1CD-04
- 527-23-1CD-02

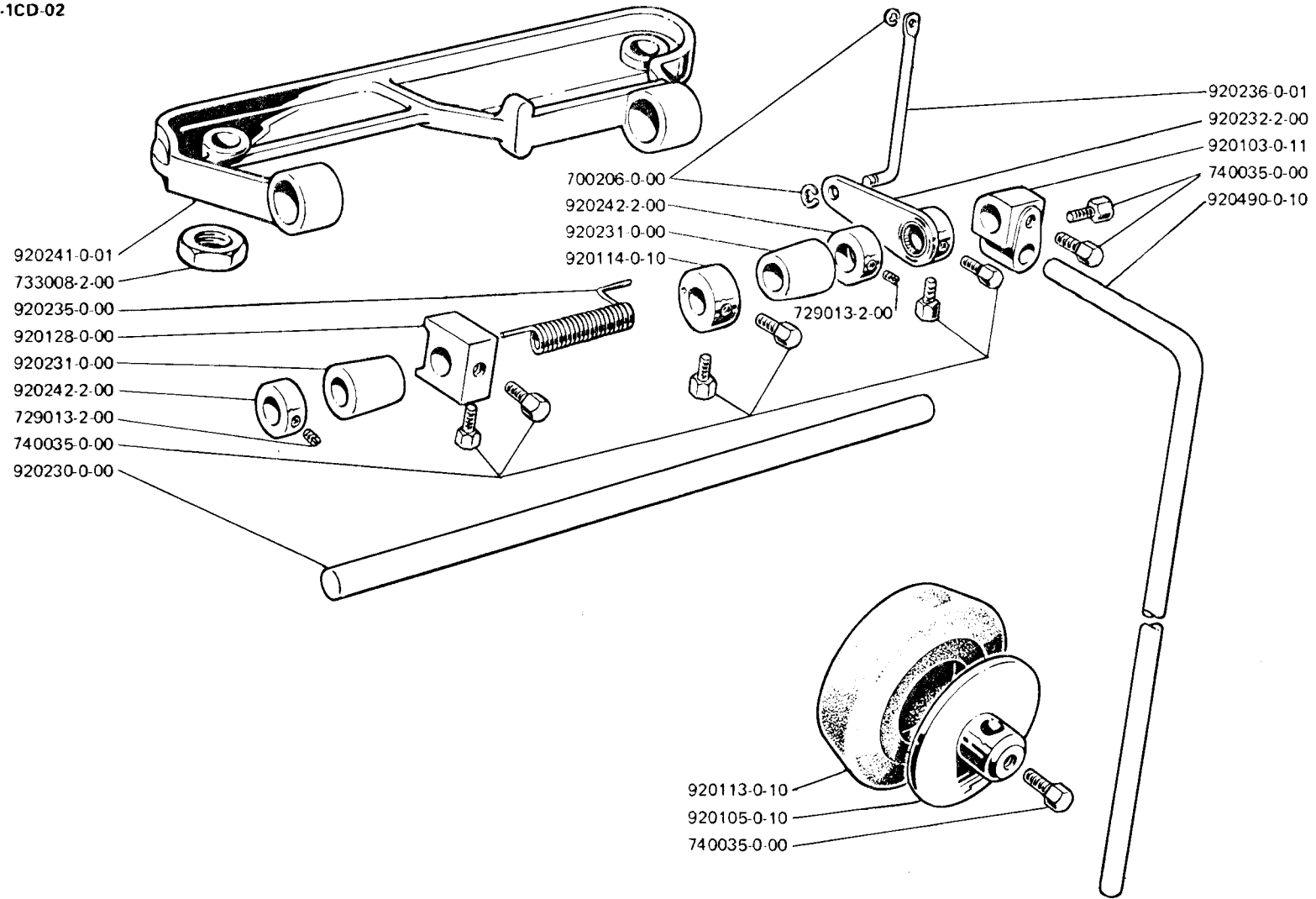

991589-4-00

- 527-01-1CD-01
- 527-01-1CD-09
- 527-16-1CD-01
- 527-23-1CD-02
- 527-38-1CD-01

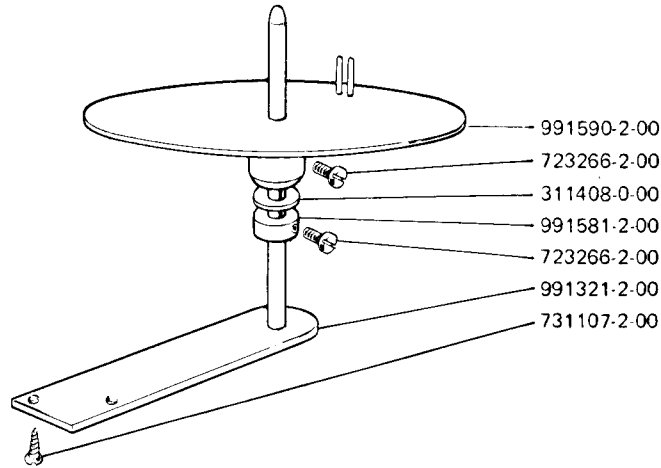

- 991590-2-00
- 723266-2-00
- 311408-0-00
- 991581-2-00
- 723266-2-00
- 991321-2-00
- 731107-2-00

991580-4-00

- 527-30-1CD-07

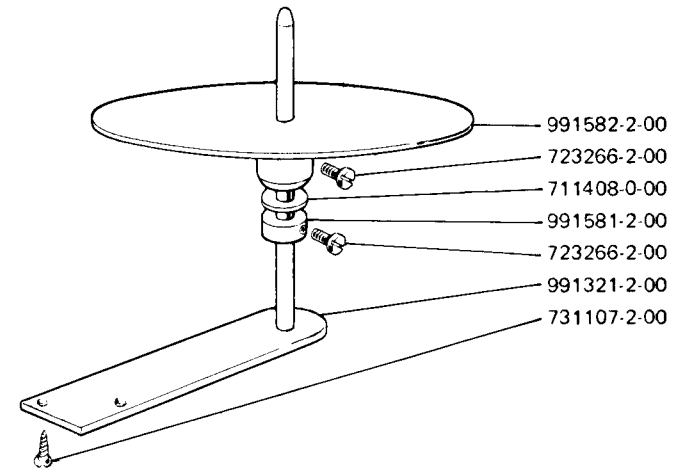

- 991582-2-00
- 723266-2-00
- 711408-0-00
- 991581-2-00
- 723266-2-00
- 991321-2-00
- 731107-2-00

991228-4-10

- 527-01-1CD-02
- 527-01-1CD-04
- 527-01-1CD-05
- 527-29-1CD-01
- 527-29-1CD-02
- 527-29-1CD-05
- 527-29-1CD-06
- 527-34-1CD-01

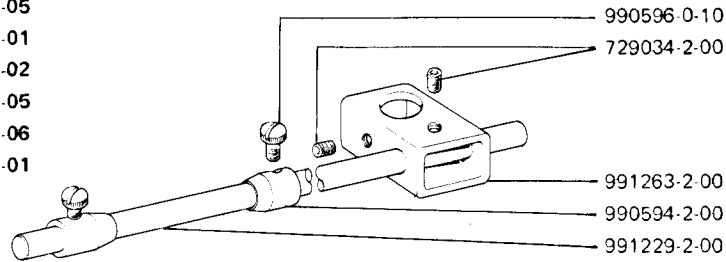

- 990596-0-10
- 729034-2-00
- 991263-2-00
- 990594-2-00
- 991229-2-00

990285-4-00

- 527-38-1CD-01

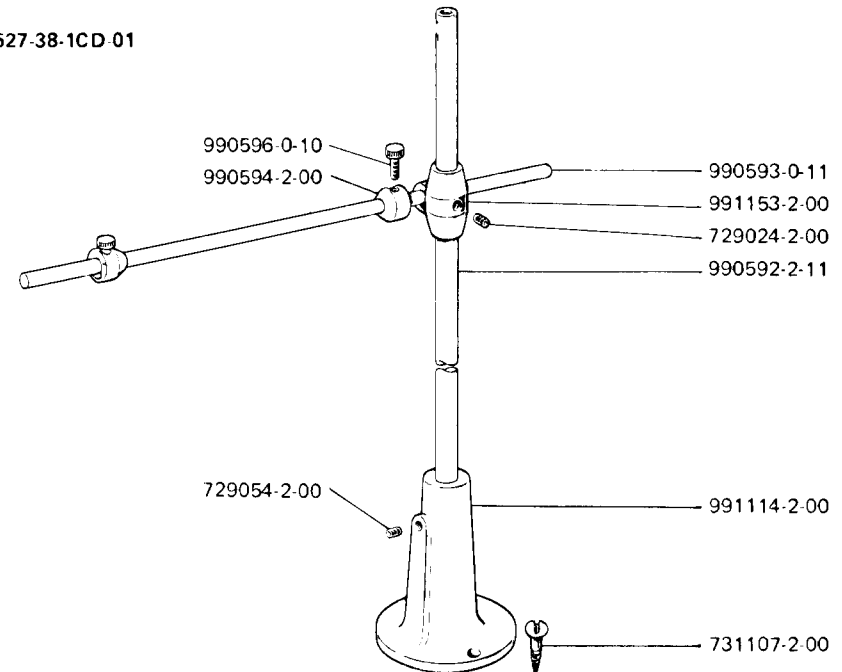

- 990596-0-10
- 990594-2-00
- 990593-0-11
- 991153-2-00
- 729024-2-00
- 990592-2-11
- 729054-2-00
- 991114-2-00
- 731107-2-00

991225-4-00

- 527-01-1CD-02
- 527-01-1CD-04
- 527-01-1CD-05
- 527-29-1CD-01
- 527-29-1CD-02
- 527-29-1CD-05
- 527-29-1CD-06
- 527-34-1CD-01

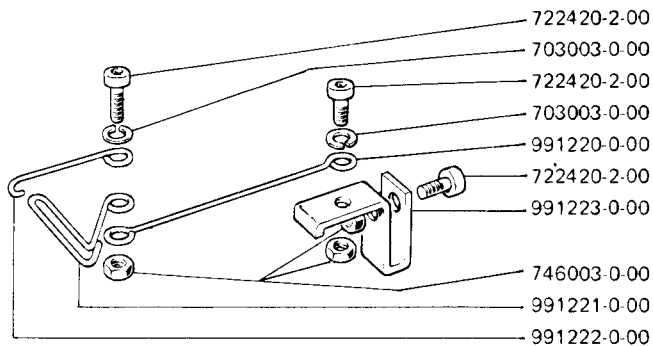

- 722420-2-00
- 703003-0-00
- 722420-2-00
- 703003-0-00
- 991220-0-00
- 722420-2-00
- 991223-0-00
- 746003-0-00
- 991221-0-00
- 991222-0-00

SOLO I PEZZI DI RICAMBIO ORIGINALI RIMOLDI MARCATI **Rim** GARANTISCONO EFFETTIVA INTERCAMBIABILITA' FUNZIONALITA', DURATA.

RIMOLDI ORIGINAL SPARE PARTS MARKED **Rim** ARE THE ONLY ONES WHICH GUARANTEE INTERCHANGEABILITY, FUNCTIONALITY, AND LONG MACHINE LIFE

EXCLUSIVEMENT LES PIECES DE RECHANGE ORIGINALES RIMOLDI MARQUEES **Rim** GARANTISSENT UNE INTERCHANGEABILITE, UN CARACTERE FONCTIONNEL, UNE DUREE EFFECTIFS.

NUR DIE MIT **Rim** MARKIERTEN RIMOLDI-ORIGINALERSATZTEILE GARANTIEREN EINE EFFEKTIVE AUSTAUSCHBARKEIT, ZWECKENTSPRECHENDHEIT, LEBENSDAUER.

SOLO EL EMPLEO EXCLUSIVO DE REPUESTOS RIMOLDI MARCADOS **Rim** ASEGURAN LA CALIDAD DE INTERCAMBIABILIDAD, LA FUNCIONALIDAD Y LA DURACION.

La Rimoldi S.r.l. si riserva il diritto di modificare o variare, per motivi d'ordine tecnico o commerciale, i dati riportati nella presente pubblicazione.

Rimoldi S.r.l. reserves the right to modify or vary, for technical or commercial reasons, the information printed in this brochure.

Rimoldi S.r.l. se réserve le droit de modifier ou changer les données établies sur la présente publication pour tous motifs d'ordre technique ou commercial.

Rimoldi S.r.l. kann jederzeit aus technischen oder kommerziellen Gründen Änderungen an den in diesem Heft beschriebenen Erzeugnissen vornehmen.

Rimoldi S.r.l. se reserva el derecho de modificar o variar, por motivos técnicos o comerciales, los datos aquí publicados.

DIRITTI RISERVATI: Nessuna riproduzione è permessa senza previa autorizzazione scritta della Rimoldi S.r.l.

ALL RIGHTS RESERVED: Reproduction in whole or in part is forbidden unless expressly authorized in writing by Rimoldi S.r.l.

DROIT RESERVES: Toute reproduction est interdite sans autorisation préalable écrite de Rimoldi S.r.l.

DERECHOS RESERVADOS: Se prohíbe la reproducción total o parcial sin previa autorización escrita de Rimoldi S.r.l.

VORBEHALTENE RECHTE: Keinerlei Wiedergabe ist ohne vorausgehender schriftlicher Genehmigung seitens der Rimoldi S.r.l. gestattet.