

CATALOGO PEZZI DI RICAMBIO  
SPARE PARTS CATALOGUE  
CATALOGUE RECHANGES  
ERSATZTEILELISTE

129-00-2CD-02

129-00-2CD-06

129-00-2CD-10

129-00-2CD-12

129-00-2MU-01

129-00-2CD-22

**n.198**

Il presente Catalogo Pezzi di Ricambio è costituito da due parti: la prima, definita come "Catalogo base", comprende i particolari montati sulla testa più significativa (la prima dell'elenco in copertina); la seconda comprende tutti i particolari delle altre teste basi o derivate, che differiscono da quella del Catalogo base.

Le Teste basi sono elencate in copertina con un carattere più grande rispetto a quello delle derivate.

Nella consultazione del Catalogo tenere presente che:

1. Tutti i particolari non fornibili sciolti non vengono richiamati singolarmente, ma soltanto illustrati nel gruppo d'appartenenza.
2. I riferimenti delle figure dei particolari che compongono il gruppo sono di norma raggruppati in una parentesi. In alcuni casi però, dove non è possibile il raggruppamento, i numeri che nelle tavole illustrative richiamano i singoli pezzi sono affiancati dallo stesso segno particolare, con cui è indicato l'intero gruppo.
3. Sulle tavole relative alle altre teste sono elencati tutti i particolari diversi o non montati sulla testa del Catalogo Base. Dette tavole portano in alto a destra il simbolo della testa cui si riferiscono (con indicato fra parentesi - nel caso di derivata - il simbolo della testa da cui deriva).  
I disegni di questo gruppo di tavole illustrano soltanto i pezzi nuovi o sostanzialmente diversi rispetto a quelli montati sulla testa più significativa del Catalogo.  
I particolari richiamati come simbolo, ma non illustrati, conservano lo stesso numero di figura dei corrispondenti raffigurati sul Catalogo base.  
I particolari comuni a tutte le teste comprese nel Catalogo, vengono richiamati soltanto nel primo gruppo di tavole.  
I particolari definiti come "pezzi annullati" si intendono quelli non montati sulla testa a cui la tavola si riferisce. Nel caso di un gruppo annullato, viene indicato soltanto il simbolo del gruppo, ma devono intendersi annullati anche tutti i particolari componenti il gruppo stesso.  
Per ogni testa viene sempre riportata interamente la tavola relativa agli organi di cucitura.

Per facilitare la ricerca viene riportato l'indice numerico di tutti i particolari illustrati sul Catalogo base, con la relativa tavola in cui gli stessi sono richiamati.

#### AGHI

Gli aghi sono contraddistinti dal sistema e dalla finezza, la quale indica il diametro medio espresso in centesimi di millimetro.

Il sistema dell'ago e la finezza sono marcati oltre che sulla busta, anche sull'ago stesso.

Nelle ordinazioni precisare, oltre il simbolo, il sistema e la finezza degli aghi desiderati. In caso di dubbio, allegare, un ago campione o una bustina vuota.

#### AVVERTENZA

Nella richiesta di parti di ricambio citare sempre il relativo numero di matricola della macchina, il simbolo del particolare e la denominazione ufficiale usata sul catalogo.

This spare parts catalogue is made up of two parts: in the first one, called "basic catalogue", all the details of most representative head are listed (the first head listed on the cover); the second one includes the details of the other main heads or derived ones, which are different from that of the basic catalogue.

The main heads are listed on the cover in bigger lettering to distinguish them from the derived heads.

When you consult the catalogue will you please note that:

1. all parts which cannot be supplied by themselves are not indicated alone, but shown together with the group to which they belong;
2. the references of the pictures of the parts making up the group are usually put in brackets.  
In some cases, however, when their grouping is not possible, the numbers of the various parts in the tables are marked with the same particular sign with which the whole group is indicated.
3. In the tables of the other heads there are listed all the parts not fitted on the head in the basic catalogue.  
These tables are marked at the top right-hand corner with the symbol of the head which the table refers to.  
The drawings in this group of tables show only the parts which are new or basically different from those fitted on the most representative head in the catalogue.  
The parts which are represented only by the symbol but not illustrated keep the same figure number as the corresponding parts shown in the basic catalogue.  
The parts which are common to all the heads in the catalogue are listed only in the first group of tables.  
Parts marked "annulled part" are those not fitted on the head which the table refers to.  
When an assembly has been annulled only the assembly symbol is specified, but all the parts forming the assembly must also be considered annulled.  
For each head the table for sewing parts is always repeated completely.

To make it easier to locate the parts, the reference numbers of all of those shown in the basic catalogue are listed together with the number of the table in which they are to be found.

#### NEEDLES

The needles are marked with system and size; the size indicates the average diameter in hundredths of a millimeter.

The system and size of the needle are shown on the packet as well as on the needle itself.

When ordering please state symbol, system and size. If you have doubts, enclose a sample needle or an empty packet with your order.

#### ATTENTION

When ordering spare parts always state the serial number of the machine, the symbol of the part in question and the description given in the catalogue.

Ce catalogue "pièces détachées" est formé de deux parties: la première appelée "catalogue base" comprend toutes les pièces montées sur la tête la plus significative (celle en tête de la liste de couverture), la seconde comprend toutes les pièces montées sur les autres têtes de base ou dérivées qui sont différentes de celle du "catalogue base".

Les têtes de base sont énumérées sur la couverture, en caractères plus grands que les têtes dérivées.

Lorsque l'on consulte le catalogue, se souvenir que:

1. Toutes les pièces qui ne sont pas fournies séparément mais qui font partie d'un groupe, ne sont pas indiquées séparément.
2. Les symboles des pièces qui forment un groupe sont regroupés entre parenthèses. Cependant, lorsque ceci n'a pas été possible, les symboles, qui dans les tables d'illustration correspondent aux pièces, sont suivis du même signe particulier qui indique le groupe tout entier.
3. Dans les tables relatives aux autres têtes, nous avons indiqué toutes les pièces différentes de celles de tête du "catalogue base" ou qui ne sont pas montées sur ces dernières. Ces tables portent, en haut à droite, le symbole des têtes auxquelles elles se réfèrent (pour les dérivées, le symbole de la tête de laquelle elles dérivent est indiqué entre parenthèses).  
Les dessins de ce groupe de tables représentent seulement les nouvelles pièces ou celles qui sont différentes des pièces montées sur la tête la plus significative du catalogue.  
Les pièces indiquées par un symbole, mais qui ne sont pas illustrées, gardent le même numéro de dessin que celles correspondantes, illustrées sur le catalogue base.  
Les pièces communes à toutes les têtes du catalogue, sont indiquées seulement dans le premier groupe de tables.  
Les pièces définies comme "pièces annulées" sont celles qui ne sont pas montées sur la tête à laquelle se réfère la table. Dans le cas de l'annulation d'un groupe, nous indiquons seulement le symbole du groupe, mais toutes les pièces qui forment ce groupe sont annulées.  
Pour chaque tête est toujours indiquée la table se référant aux organes de couture.

Pour faciliter la recherche, le catalogue renferme l'index numérique de toutes les pièces illustrées avec indication de la table dans laquelle elles sont indiquées.

#### AIGUILLES

Les aiguilles se différencient par le système et la grosseur, laquelle indique le diamètre moyen exprimé en centièmes de millimètre.

Le système de l'aiguille et sa grosseur, sont indiqués non seulement sur le sachet mais également sur l'aiguille.

Dans la commande, préciser, en plus du symbole, le système et la grosseur des aiguilles désirées. En cas de doute, joindre une aiguille comme modèle ou un sachet vide.

#### ATTENTION

Dans la commande de pièces détachées, indiquer toujours le numéro de la machine, le symbole de la pièce et la dénomination officielle mentionnée sur le catalogue.



**INDICE NUMERICO      INDEX**

Part. N.	Tav. N.	Part. N.	Tav. N.	Part. N.	Tav. N.	Part. N.	Tav. N.	Part. N.	Tav. N.	Part. N.	Tav. N.	Part. N.	Tav. N.
100620-2-10	5	202408-0-10	6	204691-0-10	12	204863-0-10	14-19	206522-3-02	9-10	206608-0-00	1	206684-0-00	5
200490-0-00	6	202412-0-10	6	204692-0-00	19	204869-0-11	14-19	206525-3-00	9-10	206609-0-00	1	206686-0-00	7
201128-0-10	7	202413-0-11	14-19	204693-0-11	14-19	204878-0-11	14-19	206529-4-01	9-10	206613-0-00	6	206689-0-00	5
201358-0-10	6	202468-0-10	8	204695-0-11	14	204889-0-10	14-19	206530-4-00	9-10	206614-2-01	6	206693-0-00	5
201610-0-01	6	202473-0-11	6	204696-0-10	14	204891-0-11	11	206531-0-00	9-10	206615-4-00	6	206695-0-00	7
202026-0-10	2	202475-0-10	6	204698-0-11	19	204894-0-11	14-19	206532-0-00	6	206617-0-00	6	206702-2-01	5
202027-0-10	3	202478-0-10	6	204699-0-11	12	204895-0-10	14-19	206533-0-00	9-10	206618-0-10	6	206711-0-00	4
202032-0-11	6	202480-0-10	3	204700-0-10	8	204905-0-10	14-19	206534-0-00	2	201619-0-00	6	206713-2-00	4
202033-0-10	6	202487-0-10	8	204704-0-10	4	204911-0-10	4	206535-0-00	4	206620-0-00	11	206714-2-00	4
202047-2-10	6	202488-0-10	6	204706-3-12	19	204912-0-10	14-19	206538-0-00	1	206621-0-00	11	206715-0-00	2
202062-2-10	7	202489-0-10	6	204747-0-10	4	204913-0-10	8	206539-0-00	1	206622-0-00	11	206716-0-00	2
202063-0-10	6	202490-0-10	6	204750-0-10	4	204947-0-10	14-19	206540-2-00	9-10	206623-2-11	11	206722-2-01	2
202065-0-20	1	202492-0-10	5	204755-2-10	8	204950-3-12	14	206543-0-01	5	206625-0-00	11	206723-4-01	2
202071-2-10	7	202529-0-10	11	204756-0-10	4	204998-0-00	14	206544-0-00	5	206626-3-00	11	206725-2-10	2
202086-0-10	7	202556-0-00	4	204757-0-11	5	204999-0-00	14	206546-0-00	6	206628-0-00	1	206726-0-11	2
202092-0-00	14	202558-2-00	4	204759-2-10	4	205021-0-10	11	206549-2-00	5	206629-0-00	1	206730-0-11	3
202092-0-10	19	202609-0-10	14	204760-4-10	4	205065-0-10	19	206564-0-00	13	206630-2-01	11	206733-0-01	3
202110-0-10	11	202681-0-10	4	204761-0-10	4	205536-0-00	14	206565-0-00	13	206632-2-00	11	206734-2-00	3
202128-0-10	12	202683-0-10	4	204762-0-11	8	205537-0-00	14	206566-0-00	13	206633-0-10	11	206735-0-00	3
202129-0-10	12	202720-0-00	7	204764-3-10	8	206340-4-00	4	206567-0-00	13	206634-0-00	11	206740-0-00	1
202130-0-11	12	203135-2-10	4	204768-0-10	1	206341-4-00	4	206568-0-01	13	206635-0-00	11	206744-0-00	2
202131-0-10	12	203187-0-10	11	204769-0-10	8	206342-4-00	4	206569-0-01	13	206636-0-00	11	206746-0-10	4
202154-0-11	9-10	203457-0-10	4	204770-0-10	1	206343-4-00	4	206572-4-00	12	206637-0-00	11	206747-0-01	4
202165-0-10	3	203630-0-10	4	204771-0-10	1	206346-4-00	4	206574-2-00	12	206638-4-00	11	206748-0-00	1
202194-0-10	11	203635-0-10	4	204773-2-10	8	206386-4-00	7	206578-2-00	5	206639-0-00	11	206754-0-00	4
202201-0-11	14	203647-2-12	4	204776-0-10	8	206410-3-00	7	206580-2-00	6	206640-0-10	11	206755-0-00	4
202214-0-10	3-11	203759-0-10	14-19	204778-3-10	8	206415-4-00	7	206582-3-00	6	206641-2-00	14	206757-0-00	12
202225-0-11	4	203783-0-10	14-19	204781-0-10	1	206429-4-01	9	206583-0-00	6	206642-0-00	11	206758-0-00	12
202227-0-10	4	204033-0-10	14-19	204787-0-10	8	206447-4-10	11	206584-2-00	6	206643-0-00	7	206764-0-00	3
202228-0-10	4	204659-0-10	8	204789-0-10	8	206452-4-00	7	206586-0-01	6	206644-2-00	11	206767-0-00	3
202229-0-10	4	204666-0-10	14	204798-0-30	1	206453-4-00	7	206587-0-01	6	206645-4-00	7	206768-0-00	3
202257-0-10	4	204667-0-10	19	204799-0-10	12	206482-3-00	14	206588-0-00	6	206651-0-00	1	206769-0-10	3
202258-0-10	4	204668-0-10	14	204800-0-10	8	206483-0-00	14	206592-3-00	6	206652-2-00	7	206790-2-00	6
202260-0-10	4	204669-0-10	19	204806-2-11	14	206484-0-00	14	206593-0-00	6	206658-2-02	7	206794-0-00	6
202271-0-11	4	204671-2-11	8	204808-2-11	14	206486-0-00	14	206594-0-00	1	206659-2-01	7	206795-0-00	6
202371-0-10	1	204674-3-10	8	204809-0-00	14	206506-0-00	9-10	206595-0-00	1	206662-0-00	13	206796-0-00	6
202385-0-10	6	204676-0-11	14-19	204819-0-10	19	206508-0-00	5	206598-3-00	6	206665-2-00	13	206797-0-00	3
202386-0-10	5	204681-0-10	12	204855-4-10	8	206514-0-00	9-10	206599-0-01	6	206667-0-00	13	206798-0-00	6
202391-0-11	11	204684-2-11	12	204860-4-10	12	206516-0-01	9-10	206603-0-10	6	206679-0-00	5	206799-0-00	6
202393-2-10	2	204687-0-10	12	204861-0-10	14-19	206518-0-00	9-10	206605-0-01	6	206682-0-01	1	206803-2-00	6
202398-0-10	2	204690-0-10	12	204862-4-10	14-19	206521-0-00	9-10	206606-2-00	6-9-10	206683-0-00	5	206804-0-00	6

INDICE NUMERICO INDEX

Part. N.	Tav. N.	Part. N.	Tav. N.	Part. N.	Tav. N.	Part. N.	Tav. N.	Part. N.	Tav. N.	Part. N.	Tav. N.	Part. N.	Tav. N.
206812-0-00	4	207486-0-00	5	704314-2-00	6	722442-2-00	13	741539-0-00	4	746402-2-00	16-17	901102-0-00	16-17
206826-3-00	9	207487-0-00	3	704345-2-00	16-17	722471-2-00	12	741546-2-00	6	746408-2-00	8	901103-0-10	17
206827-4-00	9	207488-0-00	3	704346-2-00	16	722905-2-00	16-17	741559-2-00	4	746409-2-00	16-17	901104-0-00	17
206856-0-00	1	207489-3-01	13	704406-0-00	12	722917-2-00	17	741657-0-00	4	765200-6-80	9-10	901105-0-00	17
206858-0-10	3	207490-4-02	13	704409-0-00	12	724032-0-00	6-9-10	741665-2-00	14	765500-6-80	10	925433-0-00	18
206860-0-00	5	207492-0-00	3	704409-2-00	16-17	724422-2-00	4	741682-0-00	3-4	778202-0-00	7	990075-1-13	15
206866-0-00	19	207499-0-00	13	704424-2-00	16-17	724895-2-00	3	741724-0-00	3	778203-0-00	9-10-11	990176-0-10	15
206867-2-00	3	207501-4-00	10	704536-0-00	17	727021-0-00	10	741745-2-00	6	778206-0-00	10	990179-4-11	16-17
206868-0-01	3	207506-4-00	10	704808-0-00	6	727096-0-00	11	741956-2-00	3-5	778208-0-00	9-10	990180-0-10	15
206871-4-01	6	207514-4-00	10	704813-0-00	8	727203-0-00	5	742068-2-00	16-17	778236-0-00	7	990181-0-10	15
206872-0-00	6	207524-2-00	10	704829-0-00	6	727706-0-00	9-10	742457-2-00	12	778242-0-00	2	990183-0-12	15
206875-0-00	6	207543-0-00	10	704837-0-00	9-10	727884-0-00	6	742758-0-00	12	778400-0-00	9-10	990310-0-10	16-17
206876-0-00	4	207551-4-00	4	704841-0-00	6	729011-2-00	4	743134-0-00	14	778401-0-00	7	990311-0-10	16-17
207880-2-02	3	207562-0-00	4	704845-0-00	7	729012-2-00	10	743243-2-00	7	778403-0-00	7	990314-0-10	16-17
206882-0-00	11	207756-0-00	13	704847-0-00	7	729032-2-00	6	743471-2-00	5	778405-0-00	7	990316-0-10	16-17
206884-2-00	3	207757-0-00	13	705008-0-00	6	729034-2-00	18	743497-2-00	5	778407-0-00	9-10	990324-0-10	15
206886-0-00	9-10	207758-0-00	1	705013-0-00	4-8	729051-2-00	6-11	744332-2-00	6-9-10-11	778408-0-00	8	990325-0-10	15
206966-4-02	3	207759-2-00	13	705029-0-00	9-10-12	729054-2-00	18	744334-2-00	6-9-10-12	778417-0-00	1-6	990335-0-10	13
207091-4-00	6	207762-0-00	13	705201-0-00	6	730011-2-00	6	744530-0-00	8	778421-0-00	8	990474-0-11	15
207095-2-00	7	207765-3-00	4	705208-0-00	6	730023-2-00	3	744573-0-00	12	778451-0-00	5	990577-0-10	15
207096-2-00	7	207773-4-00	4	705230-0-00	6	731107-2-00	18	744621-0-00	6	778509-0-00	9-10	990639-0-10	15
207120-0-00	4	207796-4-00	3	705408-0-00	6	733008-2-00	16-17	744631-2-00	4	778520-0-00	11	990685-0-10	15
207122-0-00	4	300218-0-10	4	705975-0-00	3	733503-0-00	4	744654-2-00	3	778826-0-00	9-10	990693-0-00	11
207123-0-00	4	301586-0-10	9-10-11	705977-0-00	13	733505-2-00	4-11	744742-0-00	2	778828-0-00	9-10	990981-0-00	16-17
207124-4-00	4	700205-0-00	16-17	705982-0-00	2	733507-2-00	16-17	745001-0-00	9-10	778832-0-00	1	990982-0-00	16-17
207140-0-00	5	700207-0-00	6	720431-2-00	4	733508-2-00	18	745002-0-00	4-9-10	778835-0-00	12	990983-0-00	16-17
207167-2-00	5	700208-0-00	8	720464-4-00	16-17	733508-4-00	16-17	745002-2-00	7	778837-0-00	9-10	990984-4-00	16-17
207170-4-01	2	701004-0-00	6	720505-4-00	16-17	733510-4-00	16-17	745114-0-00	11	788300-0-00	4	990985-0-00	15
207171-0-00	2	701006-0-00	1	720545-4-00	16-17	740220-2-00	6	745124-0-00	8	900201-0-10	16	990986-4-00	16-17
207207-4-00	2	701007-0-00	6	720566-2-00	17	740230-2-00	2	745125-2-00	6	900203-0-10	16	991106-2-00	18
207459-2-00	5	701032-0-00	13	721424-2-00	4	741092-0-00	3	745126-2-00	2	900204-0-10	16-17	991107-2-00	18
207471-3-10	1	701113-0-00	7	721435-2-00	3	741400-0-00	4	745168-0-00	7	900694-0-11	16-17	991111-2-00	18
207475-4-00	5	701116-0-00	5	721443-2-00	14-19	741403-0-00	2	745800-2-00	3-7-8-9	900918-0-00	16-17	991112-0-00	18
207478-0-00	1	701133-0-00	5	721464-2-00	11	741405-0-00	4-9-10	745803-2-00	4	900920-0-00	16-17	991113-0-00	18
207479-0-00	1	701151-0-00	13	721475-2-00	17	741413-0-00	6	745810-2-00	10	900925-4-01	16-17	991114-2-00	18
207480-2-00	1	702412-0-00	8	721484-2-00	13	741413-2-00	14-19	745812-2-00	6-7-8-9	900926-0-00	16-17	991128-2-00	18
207481-0-00	5	703005-0-00	18	721494-2-00	11	741415-2-00	10		10-11-13	900927-0-00	16-17	991135-5-00	18
207482-4-01	5	703210-0-00	9-10	721514-0-00	1	741431-0-00	14-19	746007-2-00	2-3-11	900928-0-00	16-17	991137-2-00	18
207483-0-00	5	703405-0-00	3	722031-2-00	2	741433-2-00	14	746008-0-00	6	900929-0-01	16-17	991139-3-00	18
207484-0-01	5	704009-4-00	16-17	722063-2-00	1-5-13	741453-2-00	11-14	746020-2-00	11	900931-0-00	16-17	991144-3-00	18
207485-0-00	5	704207-2-00	4	722431-2-00	18	741520-0-00	12	746208-2-00	3	901101-0-00	16-17	991179-0-00	18
												991186-0-00	16-17
												991187-0-00	16
												991188-0-00	17
												991189-0-00	16-17
												991401-4-00	15
												991415-0-00	15

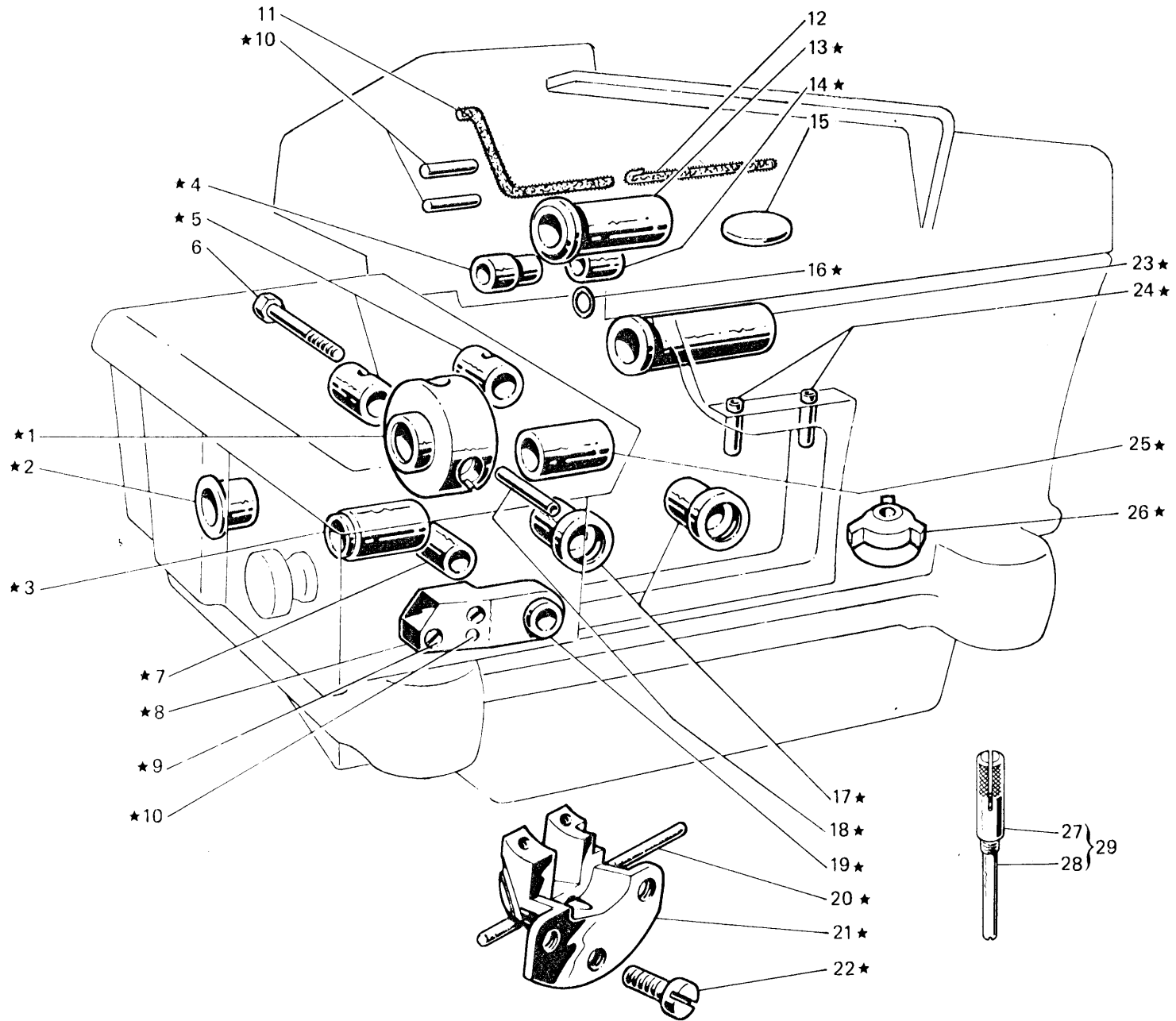

Fig. N. Abb. N.	Part. N. Piecce N. Bestell N. Pieza N.	Qt. Anzahl	DESCRIZIONE	DESCRIPTION	DESCRIPTION	BENENNUNG	DESCRIPCION
★	207471-3-10	1	base con bussole	base with bushes	base avec bagues		
1	206682-0-01	1	bussola intermedia	intermediary bush	bague intermédiaire		
2	206595-0-00	1	bussola sinistra	left bush	bague gauche		
3	204768-0-10	1	bussola	bush	bague		
4	206628-0-00	1	bussola	bush	bague		
5	206651-0-00	2	bussola posteriore	rear bush	bague-arrière		
6	204798-0-30	1	vite	screw	vis		
7	204771-0-10	1	bussola	bush	bague		
8	206856-0-00	1	blocchetto	block	bloc		
9	721514-0-00	2	vite	screw	vis		
10	202371-0-10	3	spina	pin	goupille		
11	778832-0-00	1	stoppino	wick	mèche		
12	778417-0-00	1	stoppino	wick	mèche		
13	206538-0-00	1	bussola	bush	bague		
14	206629-0-00	1	bussola destra	right bush	bague droite		
15	206748-0-00	1	tappo ad espansione	plug	bouchon		
16	701006-0-00	2	anello di tenuta	retainer ring	bague d'étanchéité		
17	202065-0-20	2	bussola anteriore	front bush	bague avant		
18	204781-0-10	1	tubetto	pipe	tube		
19	204770-0-10	1	bussola	bush	bague		
20	206609-0-00	1	guarnizione	gasket	garniture		
21	206608-0-00	1	guida slitta	guide	guide		
22	722063-2-00	3	vite	screw	vis		
23	206539-0-00	1	bussola	bush	bague		
24	206740-0-00	2	passafile	thread guide	passe-fils		
25	206594-0-00	1	bussola	bush	bague		
26	207758-0-00	1	bussola	bush	bague		
27	207479-0-00	1	tassello	small-block	tasseau		
28	207478-0-00	1	perno filettato	pin	pivot		
29	207480-2-00	1	tassello completo	small-block assembly	pivot complet		



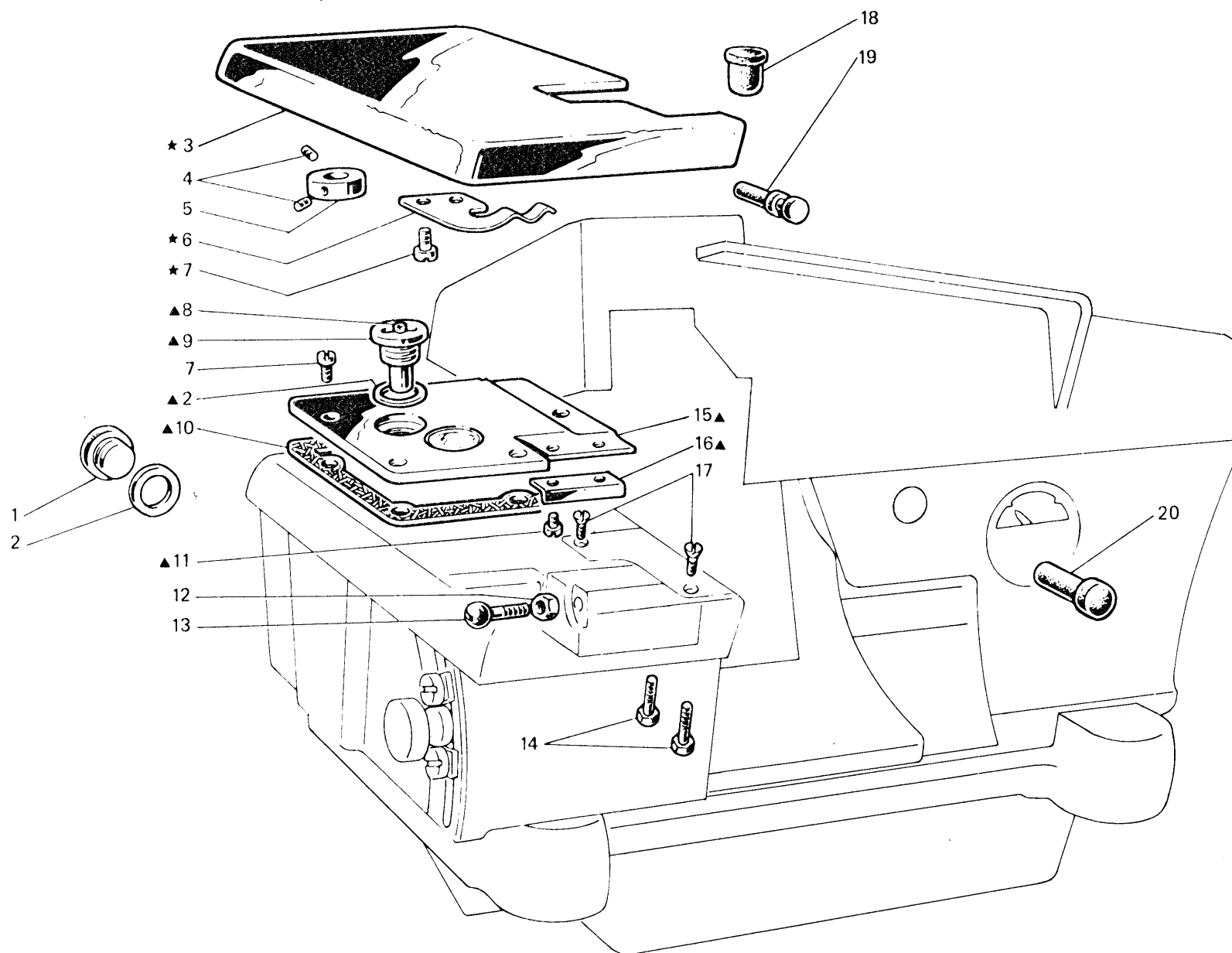

Fig. N. Abb. N.	Part. N. Piece N. Bestell N. Pieza N.	Qt. Anzahl	DESCRIZIONE	DESCRIPTION	DESCRIPTION	BENENNUNG	DESCRIPCION
▲	207170-4-01	1	coperchio cinematismo compl.	cover assembly		couvercle complet	
★	206723-4-01	1	piano di lavoro completo	working plate assembly		plan de travail complet	
1	202026-0-10	1	tappo	plug		bouchon	
2	705982-0-00	2	guarnizione	gasket		garniture	
3	206722-2-01	1	piano di lavoro	working plate		plan de travail	
4	745126-2-00	2	vite	screw		vis	
5	202393-2-10	1	anello con viti	ring with screws		anneau avec vis	
6	206716-0-00	1	molla	spring		ressort	
7	722031-2-00	7	vite	screw		vis	
8	778242-0-00	1	stoppino	wick		mèche	
9	207207-4-00	1	tappo carico olio con stoppino	oil filter plug with wick		bouchon de l'huile avec mèche	
10	206726-0-11	1	guarnizione	gasket		garniture	
11	741403-0-00	2	vite	screw		vis	
12	746007-2-00	1	dado	nut		écrou	
13	206715-0-00	1	vite testa sferica	screw		vis	
14	740230-2-00	2	vite per salva ago e spingi asola	screw for rear and front needle guard		vis pour protège-aiguille et pare-boucle	
15	206725-2-10	1	coperchio cinematismo	cover		couvercle	
16	207171-0-00	1	squadretta	bracket		équerre	
17	744742-0-00	2	vite per placca ago	screw for needle plate		vis pour plaque à aiguille	
18	206744-0-00	1	tampone	pad		tampon	
19	206534-0-00	1	tappo	plug		bouchon	
20	202398-0-10	1	tappo	plug		bouchon	

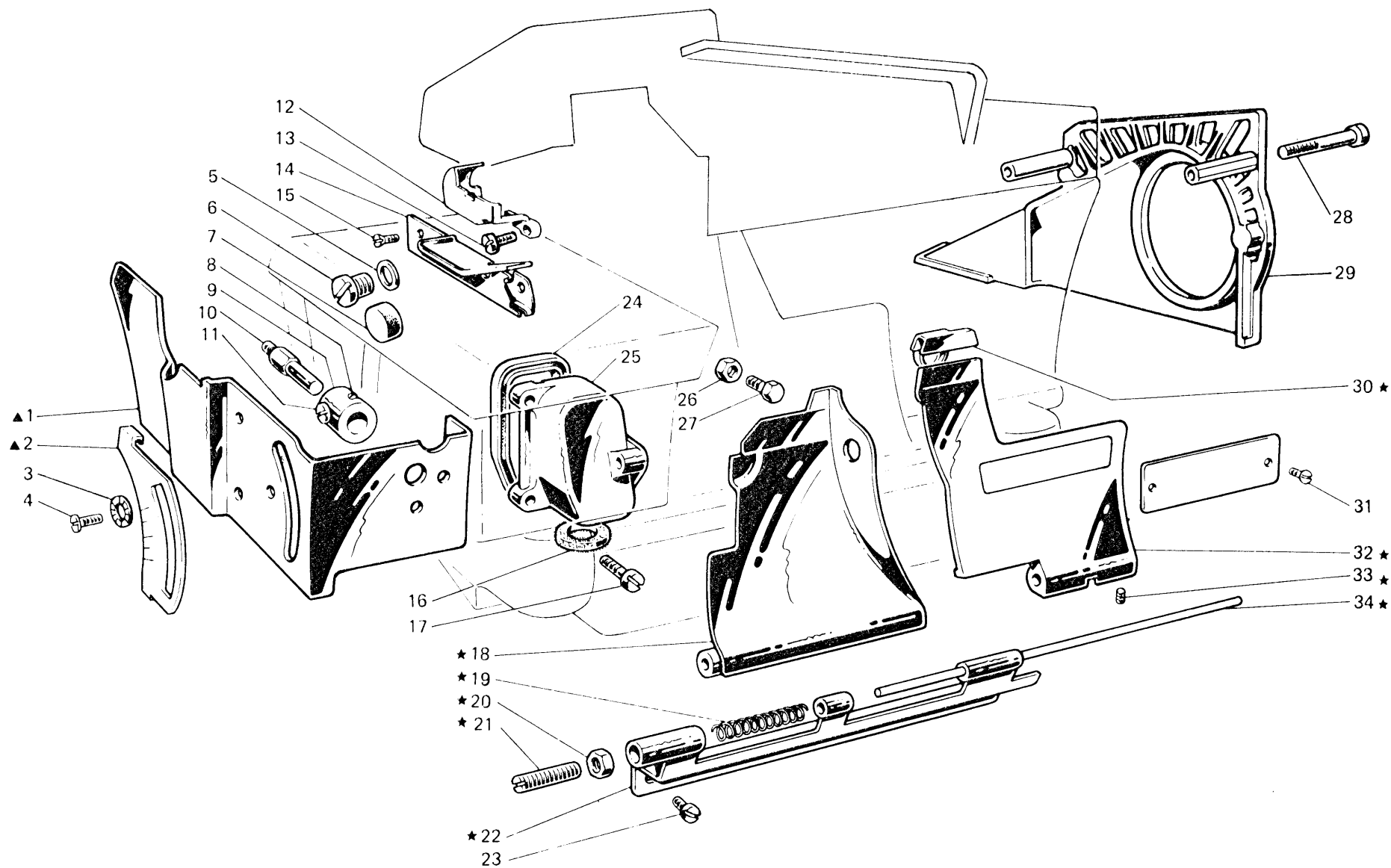

Fig. N. Abb. N.	Part. N. Piecce N. Bestell N. Pieza N.	Qt. Anzahl	DESCRIZIONE	DESCRIPTION	DESCRIPTION	BENENNUNG	DESCRIPCION
▲	206966-4-02	1	carter laterale completo	side cover assembly	carter latéral complet		
★	207796-4-00	1	sportello ant. completo	front cover assembly	carter avant complet		
1	206880-2-02	1	carter laterale	side cover	carter latéral		
2	206797-0-00	1	piastrina	plate	plaque		
3	703405-0-00	4	rondella elastica	spring washer	rondelle élastique		
4	724895-2-00	4	vite	screw	vis		
5	705975-0-00	1	rondella	washer	rondelle		
6	202480-0-10	1	tappo	plug	bouchon		
7	202027-0-10	1	tappo	plug	bouchon		
8	730023-2-00	1	vite	screw	vis		
9	206734-2-00	1	morsetto fiss. carter later.	side cover clamp	collier de serrage fixation carter lat.		
10	206733-0-01	1	vite per carter laterale	screw	vis		
11	721435-2-00	1	vite	screw	vis		
12	206730-0-11	1	vaschetta recupero olio	oil sump	cuvette huile		
13	741956-2-00	1	vite	screw	vis		
14	206735-0-00	1	carterino para olio	oil retainer	carter protection huile		
15	744654-2-00	3	vite	screw	vis		
16	206868-0-01	1	filtro	filter	filtre		
17	741682-0-00	2	vite	screw	vis		
18	206884-2-00	1	sportello scorrevole	sliding cover	carter coulissant		
19	206768-0-00	1	molla	spring	ressort		
20	746208-2-00	1	dado	nut	écrou		
21	206769-0-10	1	vite di regolazione	adjusting screw	vis de réglage		
22	207487-0-00	1	cerniera	hinge	charnière		
23	741724-0-00	4	vite	screw	vis		
24	206858-0-10	1	guarnizione	gasket	garniture		
25	206867-2-00	1	carterino con guarnizione	cover	carter		
26	746007-2-00	1	dado	nut	écrou		
27	202214-0-10	1	vite	screw	vis		
28	741092-0-00	2	vite per coperchio	screw for cover	vis pour couvercle		
29	207492-0-00	1	coperchio per cinghia	cover	couvercle		
30	206764-0-00	1	zoccolo	block	socle		
31	202165-0-10	2	vite	screw	vis		
32	207488-0-00	1	sportello ribaltabile	tipping cover	porte amovible		
33	745800-2-00	1	vite	screw	vis		
34	206767-0-00	1	perno	pin	pivot		

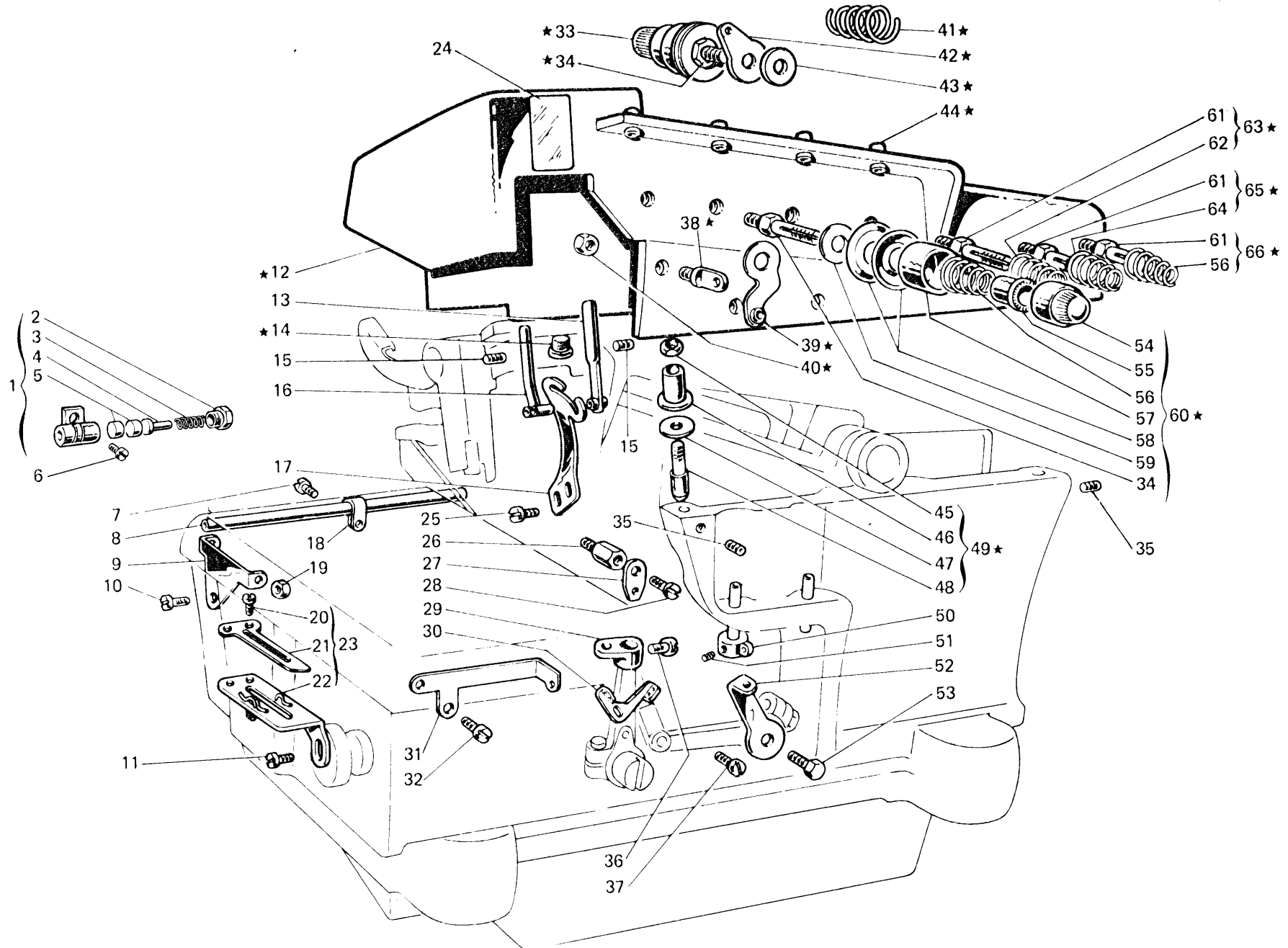

Fig. N. Abb. N.	Part. N. Bestell N. Piece N. Pieza N.	Ct. Anzahl	DESCRIZIONE	DESCRIPTION	DESCRIPTION	BENENNUNG	DESCRIPCION
★	207773-4-00	1	coperchio superiore completo	upper cover assembly	couvercle supérieur complet		
1	207551-4-00	1	pressafilo completo	thread presser assembly	presse-fil complet		
2	202260-0-10	1	tappo	plug	bouchon		
3	202257-0-10	1	molla	spring	ressort		
4	202258-0-10	1	pernetto	pin	pivot		
5	203635-0-10	2	pastiglia	plug	bouchon		
6	207562-0-00	1	vite	screw	vis		
7	741559-2-00	1	vite	screw	vis		
8	204704-0-10	1	tubetto	pipe	tube		
9	204747-0-10	1	passafilo	thread guide	passe-fil		
10	724422-2-00	1	vite	screw	vis		
11	721424-2-00	2	vite	screw	vis		
12	207765-3-00	1	coperchio con passafili	cover	couvercle		
13	206714-2-00	1	passafilo	thread guide	passe-fil		
14	206746-0-10	2	tampone	pad	tampon		
15	729011-2-00	2	vite	screw	vis		
16	203647-2-12	1	passafilo per ago	thread guide	passe-fil		
17	206535-0-00	1	tendifilo per ago	thread take-up	tendeur du fil		
18	204756-0-10	1	fascetta	clamp	bride		
19	733505-2-00	1	dado	nut	écrou		
20	741405-0-00	2	vite	screw	vis		
21	204761-0-10	1	molla	spring	ressort		
22	204759-2-10	1	mensola con spine	bracket with pin	équerre avec goupille		
23	204760-4-10	1	mensola completa	bracket assembly	équerre compl.		
24	788300-0-00	1	decalcomania sist. aghi	needles decalcomania	décalcomanie syst. aiguilles		
25	741539-0-00	2	vite	screw	vis		
26	206755-0-00	1	colonnina per passafilo	thread tube	tube pour passe-fil		
27	206812-0-00	1	passafilo crochet superiore	thread guide for upper looper	passe-fil pour crochet sup.		
28	744631-2-00	1	vite	screw	vis		
29	204750-0-10	1	squadretta	bracket	équerre		
30	204911-0-10	1	passafilo	thread guide	passe-fil		
31	206876-0-00	1	passafilo	thread guide	passe-fil		
32	741682-0-00	1	vite	screw	vis		
33	206340-4-00	1	tensione compl. con fig. 34-41	tension assembly with fig. 34-41	tension compl. avec fig. 34-41		
34	202225-0-11	2	perno per tensione fig. 33-60	pin for tension fig. 33-60	pivot pour tension fig. 33-60		
35	745803-2-00	3	vite	screw	vis		
36	741400-0-00	1	vite	screw	vis		
37	741657-0-00	1	vite	screw	vis		
38	206711-0-00	3	passafilo	thread guide	passe-fil		
39	206713-2-00	1	passafilo	thread guide	passe-fil		
40	733503-0-00	3	dado	nut	écrou		
41	203457-0-10	1	molla per tensione fig. 33	spring for tension fig. 33	ressort pour tension fig. 33		
42	203630-0-10	1	passafilo	thread guide	passe-fil		
43	705013-0-00	1	rondella	washer	rondelle		
44	202271-0-11	4	passafilo	thread guide	passe-fil		
45	207123-0-00	3	dado	nut	écrou		
46	207122-0-00	3	bussola in gomma	bush	bague		
47	704207-2-00	3	rondella	washer	rondelle		
48	207120-0-00	3	spina	pin	goupille		

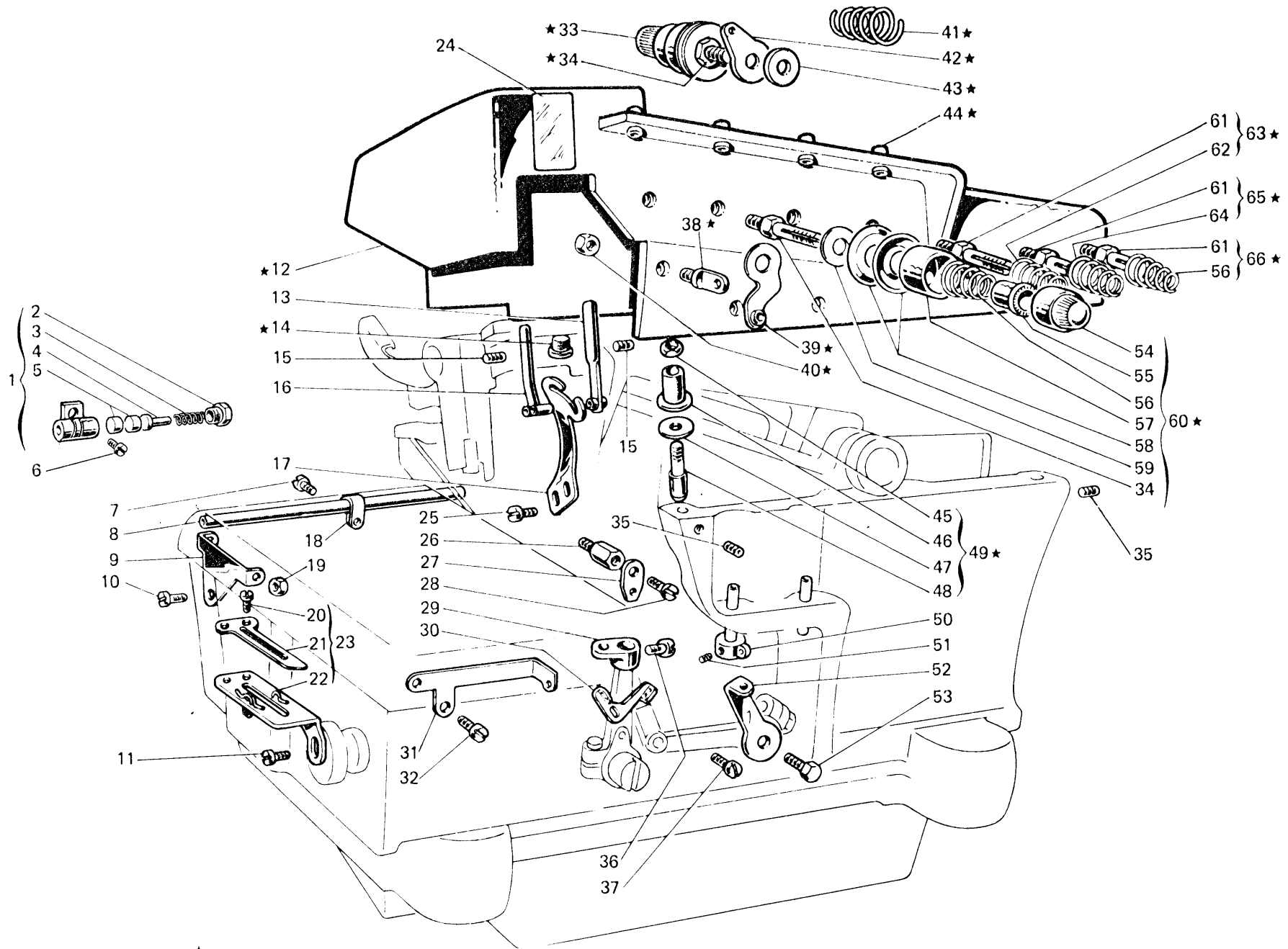

Fig. N. Abb. N.	Part. N. Bestell N. Piece N. Pieza N.	Qt. Anzahl	DESCRIZIONE	DESCRIPTION	DESCRIPTION	BENENNUNG	DESCRIPCION
49	207124-4-00	3	spina per coperchio sup.	pin for upper cover		goupille pour couvercle sup.	
50	203135-2-10	1	passafile	thread guide		passe-fil	
51	745002-0-00	1	vite	screw		vis	
52	202683-0-10	1	tendifilo crochet	thread guide		tendeur du fil	
53	720431-2-00	1	vite	screw		vis	
54	202558-2-00	5	pomolo	knob		pommeau	
55	202229-0-10	5	bussola	bush		bague	
56	202227-0-10	2	molla	spring		ressort	
57	202556-0-00	5	scodellino	cup		cuvette	
58	300218-0-10	10	disco	disc		disque	
59	206754-0-00	5	rondella	washer		rondelle	
60	206346-4-00	1	tensione completa	tension assembly		tension complète	
61	206747-0-01	3	perno per tensione completa	pin for tension assembly		pivot pour tension complète	
62	202228-0-10	1	molla per tensione compl.	spring for tension assembly		ressort pour tension complète	
63	206342-4-00	1	tensione completa	tension assembly		tension complète	
64	202681-0-10	1	molla per tensione completa	spring for tension assembly		ressort pour tension complète	
65	206343-4-00	1	tensione completa	tension assembly		tension complète	
66	206341-4-00	1	tensione completa	tension assembly		tension complète	



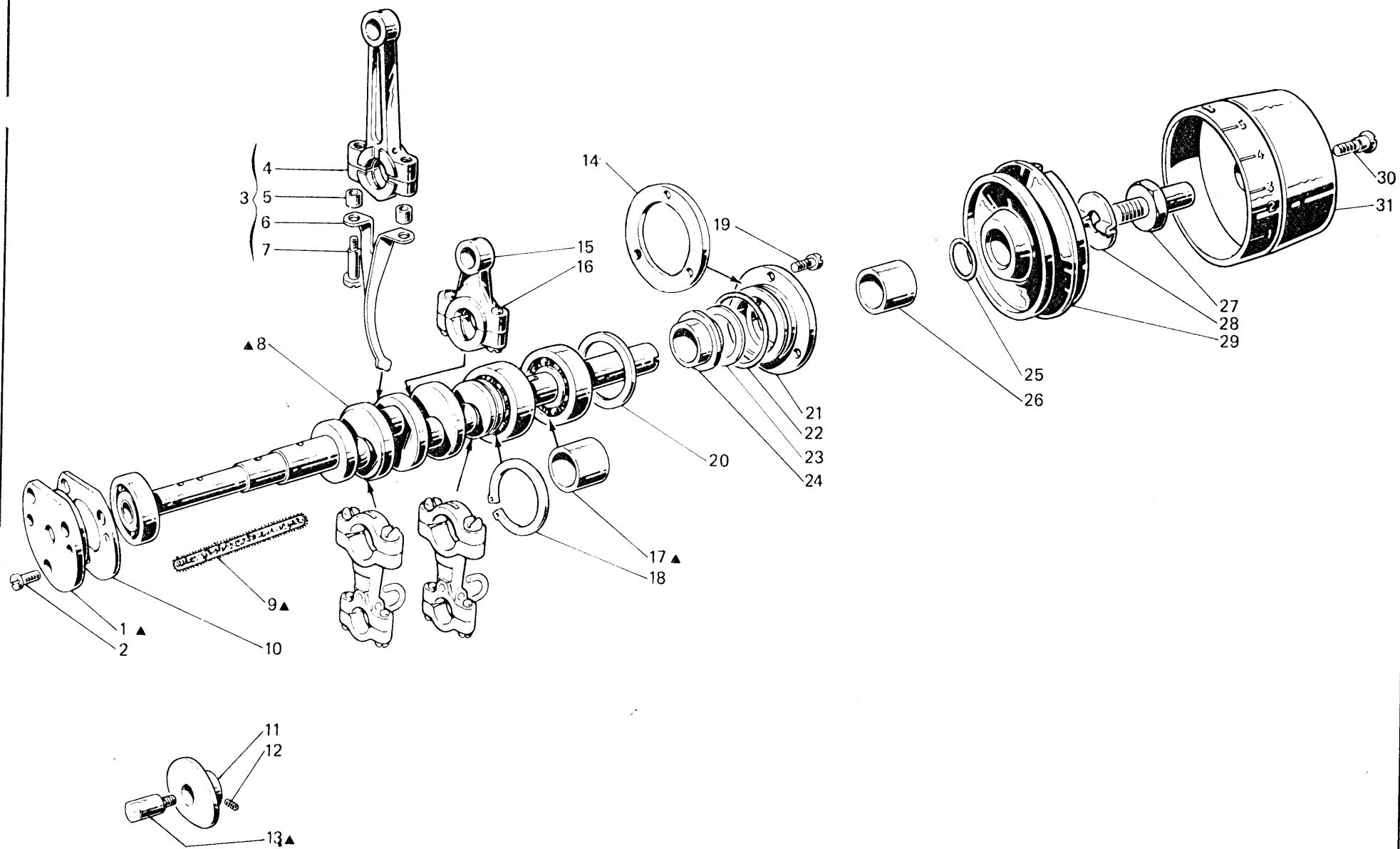

Fig. N. Abb. N.	Part. N. Bestell N. Piece N. Pieza N.	Qt. Anzahl	DESCRIZIONE	DESCRIPTION	DESCRIPTION	BENENNUNG	DESCRIPCION
▲	207475-4-00	1	albero princ.con cuscinetti	main shaft	arbre princip.avec roulements		
1	206860-0-00	1	flangia sinistra	left flange	flasque gauche		
2	741956-2-00	3	vite	screw	vis		
3	207482-4-01	1	biella con paletta completa	connecting rod assembly	bielle complète		
4	206549-2-00	1	biella albero superiore	upper connecting rod	bielle arbre supérieure		
5	207483-0-00	2	distanziale	spacer	entretoise		
6	207484-0-01	1	paletta sbatti olio	oil blade	palette huile		
7	743497-2-00	2	vite	screw	vis		
8	206702-2-01	1	albero principale	main shaft	arbre principal		
9	778451-0-00	1	stoppino	wick	mèche		
10	206543-0-01	1	guarnizione	gasket	garniture		
11	207167-2-00	1	camma tendifilo con viti	cam thread-guide	came tendeur du fil		
12	727203-0-00	2	vite	screw	vis		
13	204757-0-11	1	perno	pin	pivot		
14	206544-0-00	1	guarnizione	gasket	garniture		
15	206578-2-00	1	biella com.alb.colt.super.	connecting rod for upper knife	bielle comm.arbre couteau supérieur		
16	743471-2-00	2	vite	screw	vis		
17	207481-0-00	1	distanziale	spacer	entretoise		
18	202386-0-10	1	anello elastico	spring ring	anneau ressort		
19	722063-2-00	3	vite	screw	vis		
20	206689-0-00	1	anello di compensazione	ring	anneau		
21	207459-2-00	1	flangia con anello	flange	flasque		
22	701133-0-00	1	anello di tenuta	circlip	circlip		
23	206693-0-00	1	rondella	washer	rondelle		
24	207485-0-00	1	distanziale	spacer	entretoise		
25	701116-0-00	1	anello di tenuta	circlip	circlip		
26	207486-0-00	1	distanziale	spacer	entretoise		
27	206683-0-00	1	perno volantino	pin	pivot		
28	206684-0-00	1	chiavetta alb. principale	key	clavette		
29	206508-0-00	1	volantino	pulley	volant		
30	202492-0-10	1	vite	screw	vis		
31	206679-0-00	1	coperchio volantino	pulley cover	couvercle volant		
29	207140-0-00	1	SOLO A RICHIESTA volantino	ONLY ON REQUEST pulley	SEULEMENT SUR DEMANDE volant		

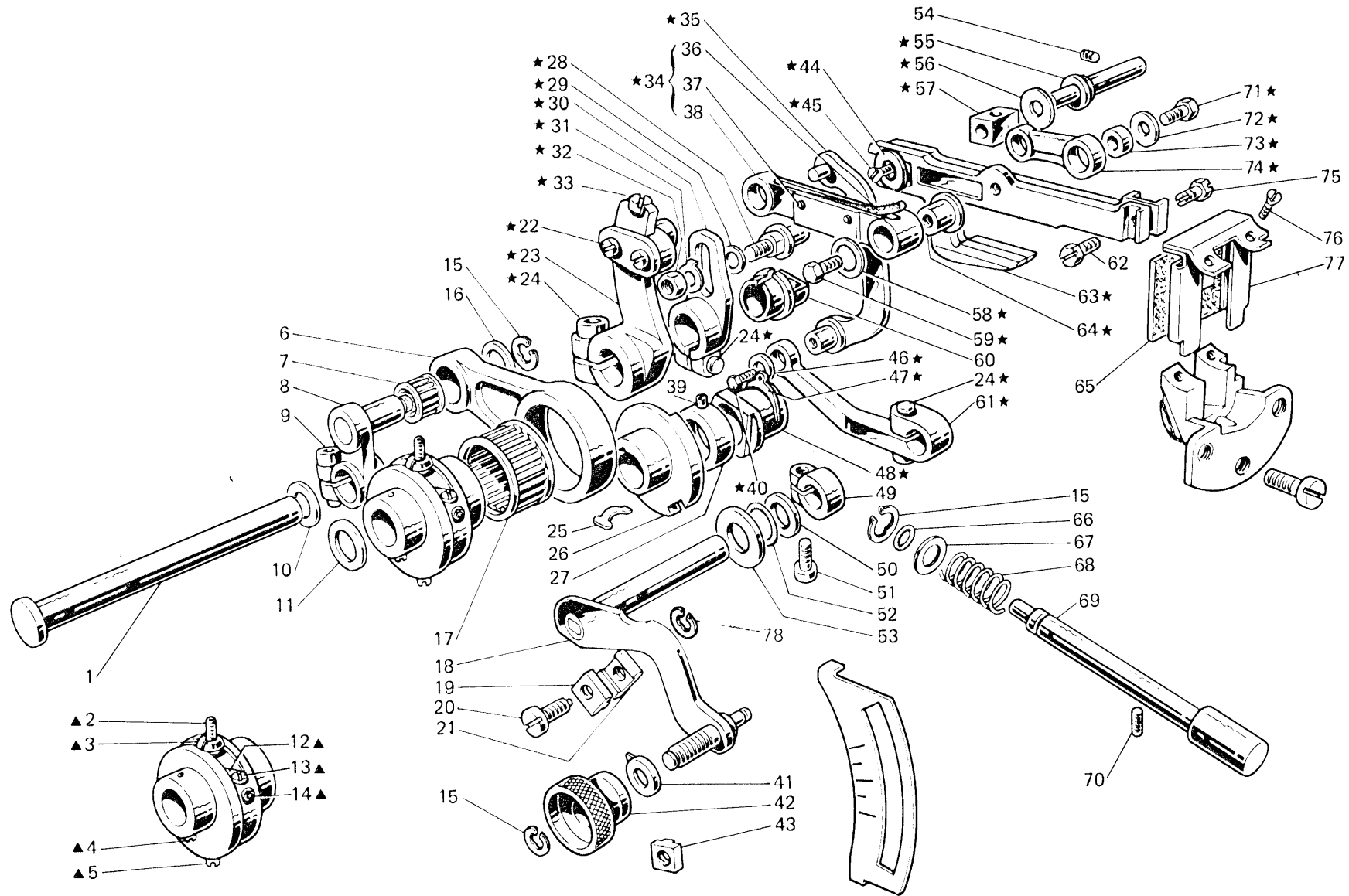

Fig. N. Abb. N.	Part. N. Bestell N. Pieca N. Pieza N.	Qt. Anzahl	DESCRIZIONE	DESCRIPTION	DESCRIPTION	BENENNUNG	DESCRIPCION
★	207091-4-00	1	gruppo comando griffe	feed dog control assembly	groupe commande griffe		
▲	206871-4-01	1	gruppo eccentr,regol,trasporto	eccentric groupe	groupe eccentric		
1	206593-0-00	1	contralbero trasporto	transport countershaft	axe transport		
2	729051-2-00	1	vite	screw	vis		
3	206603-0-10	1	fermo eccentrico	eccentric retainer	pièce blocage excentrique		
4	745125-2-00	1	vite	screw	vis		
5	727884-0-00	1	vite	screw	vis		
6	206599-0-01	1	biella comando trasporto	transport connecting rod control	bielle commande transport		
7	201358-0-10	1	gabbia a rullini	needles cage	cage à aiguilles		
8	206598-3-00	1	braccio a manovella con vite	connecting-rod with screw	bras à manivelle avec vis		
9	744334-2-00	1	vite	screw	vis		
10	704841-0-00	1	rondella	washer	rondelle		
11	206532-0-00	1	rondella	washer	rondelle		
12	202412-0-10	1	lardone	gib	lardon		
13	202473-0-11	2	vite	screw	vis		
14	730011-2-00	2	vite	screw	vis		
15	700207-0-00	3	anello elastico	spring ring	anneau ressort		
16	206546-0-00	1	rondella	washer	rondelle		
17	202385-0-10	1	gabbia a rullini	needles cage	cage à aiguilles		
18	206790-2-00	1	leva comando slitta	lever	levier		
19	206799-0-00	1	arresto regolabile esterno	external retainer	butée réglable externe		
20	206875-0-00	2	vite	screw	vis		
21	206795-0-00	2	arresto regolabile interno	internal retainer	butée réglable interne		
22	741546-2-00	2	vite	screw	vis		
23	206592-3-00	1	manovella trasporto con viti	transport crank with screws	manivelle transport avec vis		
24	744332-2-00	3	vite	screw	vis		
25	206872-0-00	1	molla	spring	ressort		
26	206605-0-01	1	eccentrico	eccentric	excentrique		
27	206606-2-00	1	anello di rasamento	shim	bague		
28	202063-0-10	1	spina	pin	goupille		
29	704808-0-00	1	rondella	washer	rondelle		
30	206584-2-00	1	braccio manovella	connecting rod	bras à manivelle		
31	206580-2-00	1	rondella con spina	washer with pin	rondelle avec pivot		
32	746008-0-00	1	dado	nut	écrou		
33	741413-0-00	1	vite	screw	vis		
34	206615-4-00	1	biellino completo	connecting rod assembly	petite bielle complète		
35	202047-2-10	1	leva	lever	levier		
36	778417-0-00	1	stoppino	wick	mèche		
37	200490-0-00	2	spillo	pin	goupille		
38	206587-0-01	1	biellino	connecting rod	petite bielle		
39	745812-2-00	2	vite	screw	vis		
40	740220-2-00	1	vite	screw	vis		
41	206796-0-00	1	indice rapp. differ.	differential index	indice différentiel		
42	206798-0-00	1	bottono rapporto differenziale	differential button	bouton différentiel		
43	206794-0-00	1	arresto regolabile esterno	external retainer	butée réglable externe		
44	202475-0-10	1	rondella	washer	rondelle		
45	724032-0-00	1	vite	screw	vis		
46	705201-0-00	1	rondella	washer	rondelle		
47	201610-0-01	1	anello elastico	spring ring	anneau ressort		

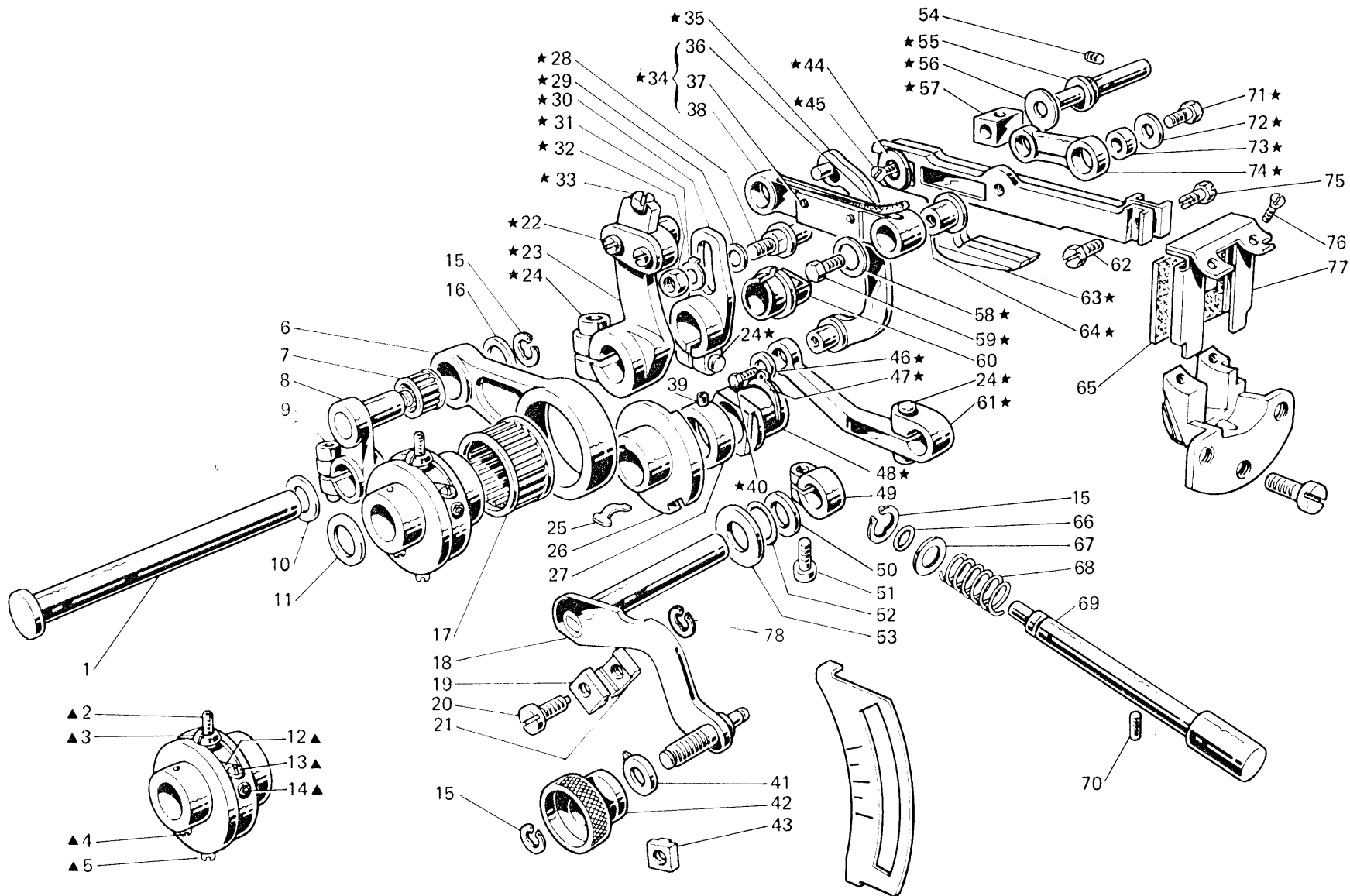

Fig. N. Abb. N.	Part. N. Bestell N. Piece N. Pieza N.	Qt. Anzahl	DESCRIZIONE	DESCRIPTION	DESCRIPTION	BENENNUNG	DESCRIPCION
48	206617-0-00	1	blocchetto	block	bloc		
49	100620-2-10	1	morsetto con vite	clamp with screws	collier de serrage avec vis		
50	704829-0-00	1	rondella	washer	rondelle		
51	741745-2-00	1	vite	screw	vis		
52	701007-0-00	1	anello di tenuta	circlip	circlip		
53	705230-0-00	1	rondella	washer	rondelle		
54	202478-0-10	1	vite	screw	vis		
55	206613-0-00	1	perno eccentrico	eccentric pin	pivot excentrique		
56	705408-0-00	1	rondella	washer	rondelle		
57	202033-0-10	1	blocchetto	block	bloc		
58	705008-0-00	1	rondella	washer	rondelle		
59	206588-0-00	1	vite	screw	vis		
60	206619-0-00	1	vaschetta olio	oil sump	cuvette huile		
61	206614-2-01	1	braccio regol. differenziale	differential arm	bras différentiel		
62	202489-0-10	1	vite	screw	vis		
63	206582-3-00	1	gruppo slitta porta griffe	feed dog slide groupe	groupe support porte-griffe		
64	206586-0-01	1	bussola per biellino	bush	bage		
65	206804-0-00	1	raschia olio	oil scraper	râcheur d'huile		
66	701004-0-00	1	anello	ring	anneau		
67	704314-2-00	1	rondella	washer	rondelle		
68	202408-0-10	1	molla	spring	ressort		
69	206618-0-10	1	pulsante reg. punto	push.button	poussoir réglage point		
70	729032-2-00	1	vite	screw	vis		
71	202490-0-10	1	vite	screw	vis		
72	705208-0-00	1	rondella	washer	rondelle		
73	202032-0-11	1	bussolina	bush	bage		
74	206583-0-00	1	biellino	connecting-rod	petite bielle		
75	202488-0-10	1	vite	screw	vis		
76	744621-0-00	2	vite	screw	vis		
77	206803-2-00	1	telaio raschiaolio	oil scraper frame	râcheur d'huile		
78	700206-0-00	2	anello elastico	spring ring	anneau ressort		

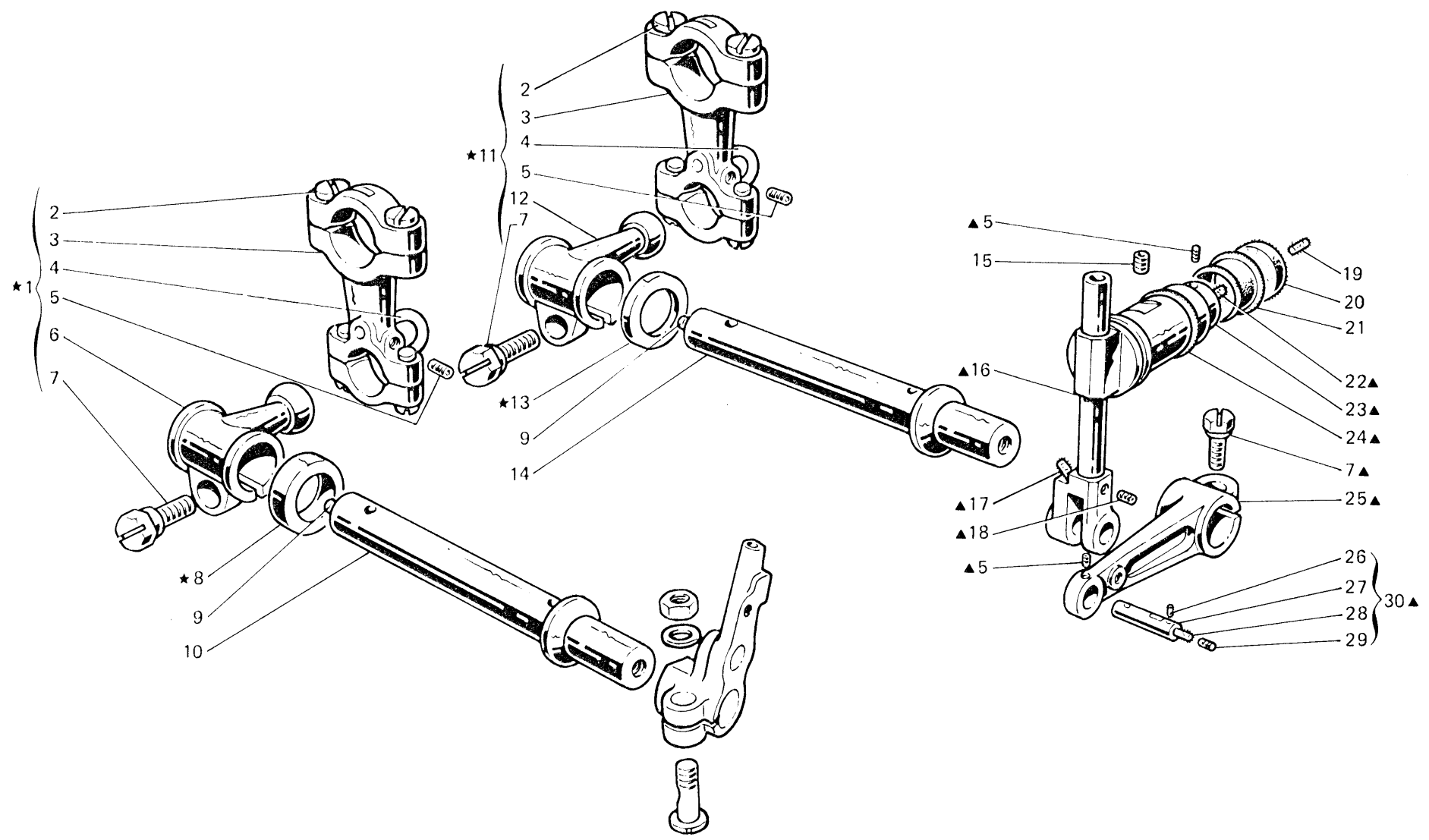

Fig. N. Abb. N.	Part. N. Pecce N. Bestell N. Pieza N.	Qt. Anzahl	DESCRIZIONE	DESCRIPTION	DESCRIPTION	BENENNUNG	DESCRIPCION
★	206386-4-00	1	gruppo manicotti com.crochet	looper control coupling assembly	groupe manchon comm.crochet		
▲	206415-4-00	1	gruppo comando crochet super.	upper looper control	groupe commande crochet sup.		
1	206453-4-00	1	gruppo manicotto con biella	coupling ass.with con-rod	groupe manchon avec bielle		
2	743243-2-00	8	vite per biella	screw	vis		
3	202071-2-10	2	biella con viti	con rod with screws	bielle avec vis		
4	206643-0-00	2	cavallotto	coupling	cavalier		
5	745800-2-00	4	vite	screw	vis		
6	206659-2-01	1	manicotto	coupling	manchon		
7	201128-0-10	3	vite	screw	vis		
8	704847-0-00	1	rondella	washer	rondelle		
9	206695-0-00	2	tappo per albero	plug for shaft	bouchon pour arbre		
10	207096-2-00	1	albero crochet inferiore	shaft lower looper	arbre crochet inférieur		
11	206452-4-00	1	gruppo manicotto con biella	coupling with con-rod ass.	groupe manchon avec bielle		
12	206658-2-02	1	manicotto	coupling	manchon		
13	704845-0-00	1	rondella	washer	rondelle		
14	207095-2-00	1	albero crochet superiore	upper looper shaft	arbre crochet inférieur		
15	745168-0-00	1	vite	screw	vis		
16	206410-3-00	1	guida oscillante	oscillating guide	guide oscillant		
17	778403-0-00	1	stoppino	wick	mèche		
18	745812-2-00	1	vite	screw	vis		
19	778236-0-00	1	stoppino	wick	mèche		
20	206686-0-00	1	disco lubrificazione guida	disc	disque		
21	202720-0-00	1	paraolio	oil retainer	pare-huile		
22	778405-0-00	1	stoppino	wick	mèche		
23	202062-2-10	1	anello con vite	ring with screws	anneau avec vis		
24	701113-0-00	1	anello di tenuta	circlip	circlip		
25	206652-2-00	1	braccio	arm	bras		
26	778202-0-00	4	stoppino	wick	mèche		
27	202086-0-10	1	spina	pin	goupille		
28	778401-0-00	1	stoppino	wick	mèche		
29	745002-2-00	1	vite	screw	vis		
30	206645-4-00	1	spina completa	pin assembly	goupille compl.		



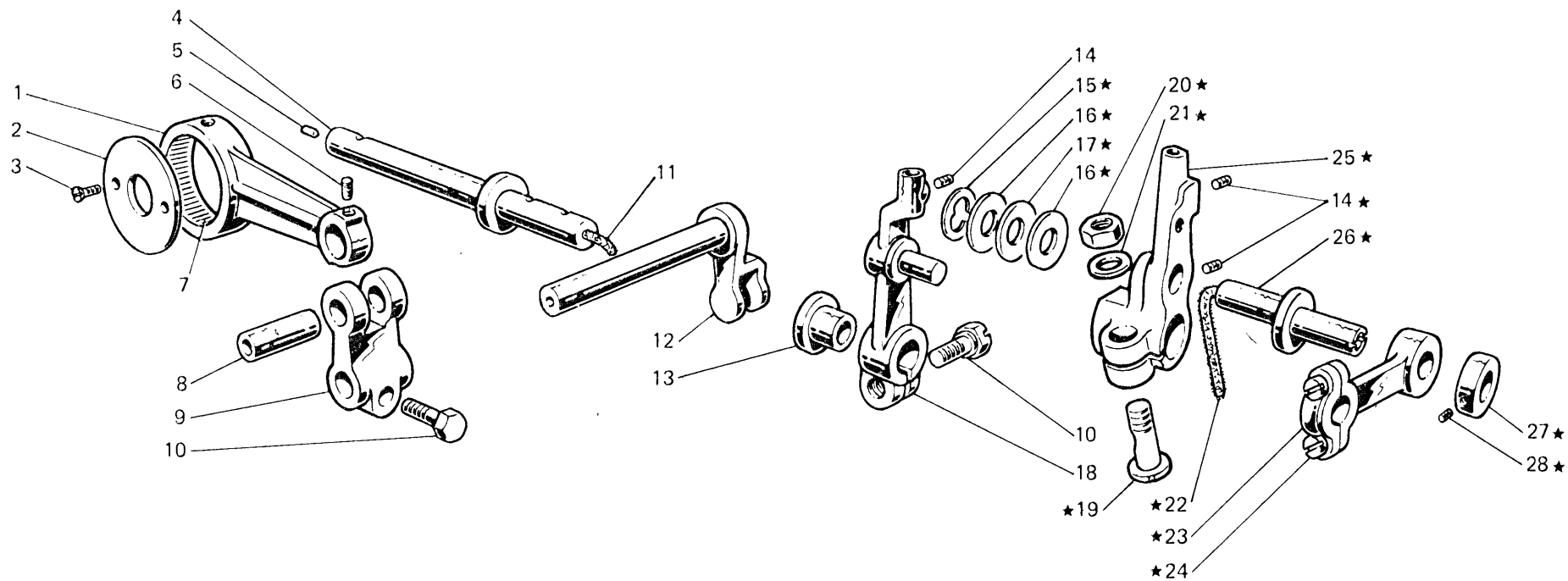

Fig. N. Abb. N.	Part. N. Bestell N. Piece N. Pieza N.	Qt. Anzahl	DESCRIZIONE	DESCRIPTION	DESCRIPTION	BENENNUNG	DESCRIPCION
★	204855-4-10	1	porta crochet infer.compl.	lower looper holder assembly	porte crochet inférieur compl.		
1	204762-0-11	1	biella comando crochet	looper control con-rod	bielle commande crochet		
2	204789-0-10	1	rondella	washer	rondelle		
3	744530-0-00	2	vite	screw	vis		
4	204778-3-10	1	alberino con stopp.e tappo	shaft with wick and plug	arbre avec mèche et bouchon		
5	202468-0-10	1	tappo	plug	bouchon		
6	745124-0-00	1	vite	screw	vis		
7	204787-0-10	1	gabbia a rullini	needle cage	cage à aiguille		
8	204659-0-10	1	spina per attacco a forcella	pin for coupling	goupille pour fourche		
9	204755-2-10	1	attacco a forcella con vite	coupling with screw	raccord à fourche avec vis		
10	202487-0-10	2	vite	screw	vis		
11	778421-0-00	1	stoppino	wick	mèche		
12	204776-0-10	1	perno con forcella	pin with fork	pivot avec fourche		
13	204769-0-10	1	bussola	bush	bague		
14	745812-2-00	3	vite fissaggio crochet	looper screw	vis blocage crochet		
15	700208-0-00	1	anello elastico	circlip	circlip		
16	704813-0-00	2	rondella	washer	rondelle		
17	702412-0-00	1	molla a tazza	cup spring	ressort à tasse		
18	204674-3-10	1	porta crochet con vite	looper holder with screw	porte crochet avec vis		
19	204700-0-10	1	perno a vite	threaded pin	pivot à vis		
20	746408-2-00	1	dado	nut	écrou		
21	705013-0-00	1	rondella	washer	rondelle		
22	778408-0-00	1	stoppino	wick	mèche		
23	204764-3-10	1	biella	con-rod	bielle		
24	204800-0-10	2	vite	screw	vis		
25	204671-2-11	1	porta crochet inferiore	lower looper holder	porte crochet inférieur		
26	204913-0-10	1	spina eccentrica	eccentric pin	pivot excentrique		
27	204773-2-10	1	anello di registro	adjustment ring	anneau de réglage		
28	745800-2-00	2	vite	screw	vis		

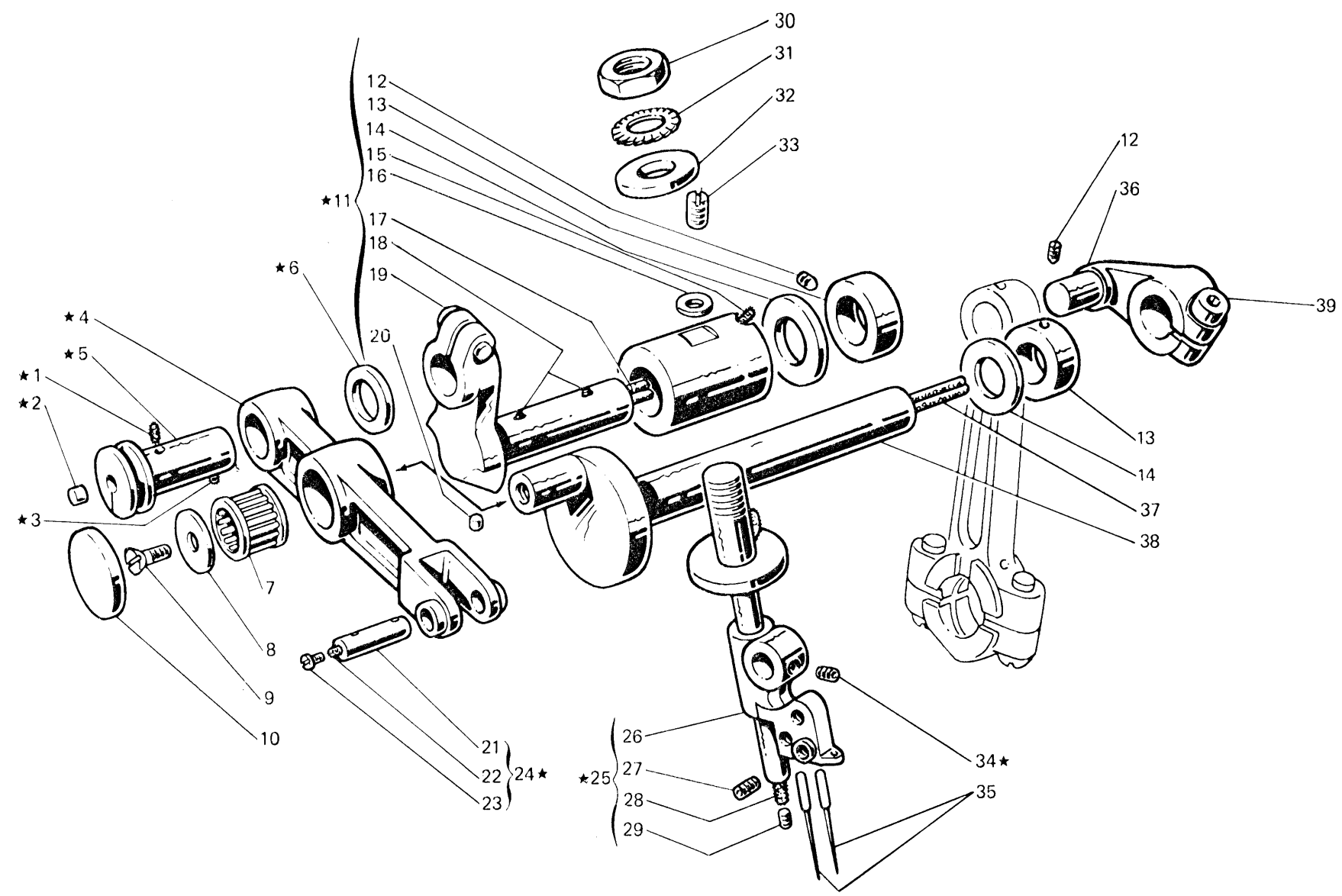

Fig. N. Abb. N.	Part. N. Piece N. Bestell N. Pieza N.	Qt. Anzahl	DESCRIZIONE	DESCRIPTION	DESCRIPTION	BENENNUNG	DESCRIPCION
★	206429-4-01	1	cinematismo comando ago	needle control assembly	cinématisme commande aiguille		
1	778826-0-00	1	stoppino	wick	mèche		
2	206521-0-00	1	tappo	plug	bouchon		
3	778828-0-00	1	stoppino	wick	mèche		
4	206516-0-01	1	leva	lever	levier		
5	206525-3-00	1	perno con stoppini e tappo	pin with wicks and plug	pivot avec mèches et bouchon		
6	704837-0-00	1	rondella	washer	rondelle		
7	206518-0-00	1	gabbia a rullino	needle cage	cage à aiguille		
8	206531-0-00	1	rondella	washer	rondelle		
9	724032-0-00	1	vite	screw	vis		
10	206533-0-00	1	coperchio per leva	cover for lever	couvercle pour levier		
11	206522-3-02	1	albero a manovella con bussole	shaft with bushes	arbre avec bagues		
12	745812-2-00	2	vite	screw	vis		
13	206606-2-00	2	anello	ring	anneau		
14	705029-0-00	2	rondella	washer	rondelle		
15	778509-0-00	1	stoppino	wick	mèche		
16	206886-0-00	1	dischetto	disc	disque		
17	778407-0-00	1	stoppino	wick	mèche		
18	778203-0-00	4	stoppino	wick	mèche		
19	744332-2-00	1	vite	screw	vis		
20	301586-0-10	1	tappo	plug	bouchon		
21	202154-0-11	1	spina	pin	goupille		
22	778208-0-00	1	stoppino	wick	mèche		
23	741405-0-00	1	vite	screw	vis		
24	206529-4-01	1	spina completa	pin assembly	goupille compl.		
25	206827-4-00	1	morsetto con barra compl.	clamp assembly	collier de serrage compl.		
26	206826-3-00	1	morsetto con barra	clamp with bar	collier de serrage avec barre		
27	745800-2-00	2	vite	screw	vis		
28	778400-0-00	1	stoppino	wick	mèche		
29	745001-0-00	1	vite	screw	vis		
30	206506-0-00	1	dado	nut	écrou		
31	703210-0-00	1	rondella	washer	rondelle		
32	206514-0-00	1	rondella	washer	rondelle		
33	727706-0-00	1	vite	screw	vis		
34	745002-0-00	1	vite	screw	vis		
35	765200-6-80	2	ago sist. Rim27 fin.80	needle syst. Rim27 size 80	aiguille syst. Rim27 jauge 80		
36	206540-2-00	1	manovella alb. sup. con vite	con-rod with screw	bras arbre sup. avec vis		
37	778837-0-00	1	stoppino	wick	arbre		
38	206530-4-00	1	albero compl. con stoppino	shaft assembly	arbre complet		
39	744334-2-00	1	vite per manovella	screw	vis		

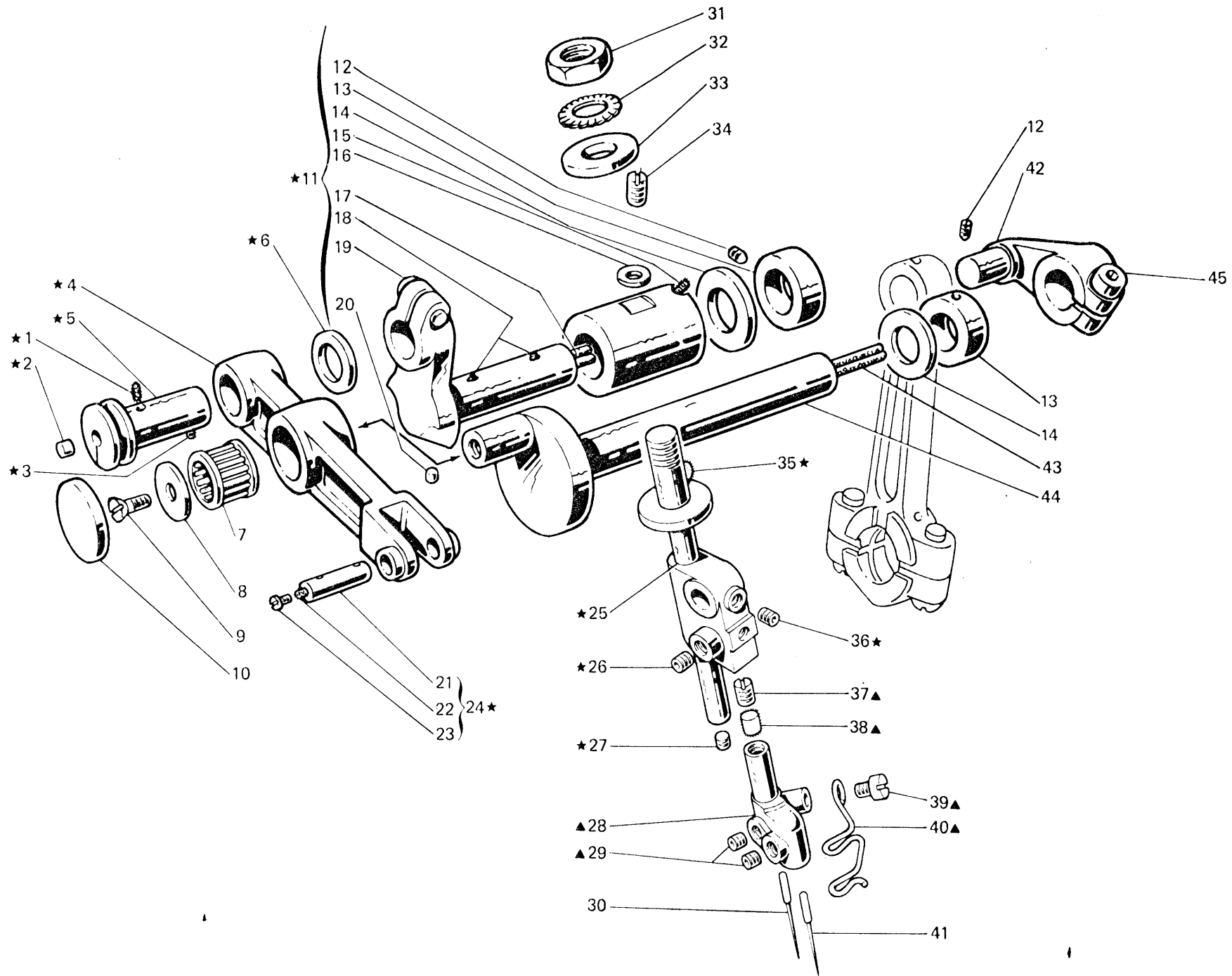

Fig. N. Abb. N.	Part. N. Bestell N. Piece N. Pieza N.	Qt. Anzahl	DESCRIZIONE	DESCRIPTION	DESCRIPTION	BENENNUNG	DESCRIPCION
★	207501-4-00	1	cinematismo comando aghi	needles control assembly	cinématisme comm. aiguilles		
▲	207514-4-00	1	morsetto porta aghi compl.	needles clamp assembly	porte-aiguilles complet		
1	778826-0-00	1	stoppino	wick	mèche		
2	206521-0-00	1	tappo	plug	bouchon		
3	778828-0-00	1	stoppino	wick	mèche		
4	206516-0-01	1	leva	lever	levier		
5	206525-3-00	1	perno con stoppini e tappo	pin with wicks and plug	pivot avec mèches et bouchon		
6	704837-0-00	1	rondella	washer	rondelle		
7	206518-0-00	1	gabbia a rullino	needle cage	cage à aiguille		
8	206531-0-00	1	rondella	washer	rondelle		
9	724032-0-00	1	vite	screw	vis		
10	206533-0-00	1	coperchio per leva	cover for lever	couvercle pour levier		
11	206522-3-02	1	albero a manovella con bussole	shaft with bushes	arbre avec bagues		
12	745812-2-00	2	vite	screw	vis		
13	206606-2-00	2	anello	ring	anneau		
14	705029-0-00	2	rondella	washer	rondelle		
15	778509-0-00	1	stoppino	wick	mèche		
16	206886-0-00	1	dischetto	disc	disque		
17	778407-0-00	1	stoppino	wick	mèche		
18	778203-0-00	4	stoppino	wick	mèche		
19	744332-2-00	1	vite	screw	vis		
20	301586-0-10	1	tappo	plug	bouchon		
21	202154-0-11	1	spina	pin	goupille		
22	778208-0-00	1	stoppino	wick	mèche		
23	741405-0-00	1	vite	screw	vis		
24	206529-4-01	1	spina completa	pin assembly	goupille compl.		
25	207506-4-00	1	slitta con barra compl.	slide with bar assembly	glissière avec barre compl.		
26	729012-2-00	1	vite	screw	vis		
27	745001-0-00	1	vite	screw	vis		
28	207524-2-00	1	morsetto porta aghi	needles clamp assembly	porte-aiguilles complet		
29	745810-2-00	2	vite	screw	vis		
30	765200-6-80	1	ago sist. Rim 27 fin. 80	needle syst. Rim 27 size 80	aiguille syst. Rim 27 jauge 80		
31	206506-0-00	1	dado	nut	écrou		
32	703210-0-00	1	rondella	washer	rondelle		
33	206514-0-00	1	rondella	washer	rondelle		
34	727706-0-00	1	vite	screw	vis		
35	778400-0-00	1	stoppino	wick	mèche		
36	745002-0-00	1	vite	screw	vis		
37	727021-0-00	1	vite	screw	vis		
38	778206-0-00	1	stoppino	wick	mèche		
39	741415-2-00	1	vite	screw	vis		
40	207543-0-00	1	guidafilo	thread guide	guide-fil		
41	765500-6-80	1	ago sist. Rim 29 fin. 80 punta 6	needle syst. Rim 29 size 80	aiguille syst. Rim 29 jauge 80		
42	206540-2-00	1	manovella alb. sup. con vite	con-rod with screw	bras arbre sup. avec vis		
43	778837-0-00	1	stoppino	wick	mèche		
44	206530-4-00	1	albero compl. con stoppino	shaft assembly	arbre complet		
45	744334-2-00	1	vite per manovella	screw	vis		

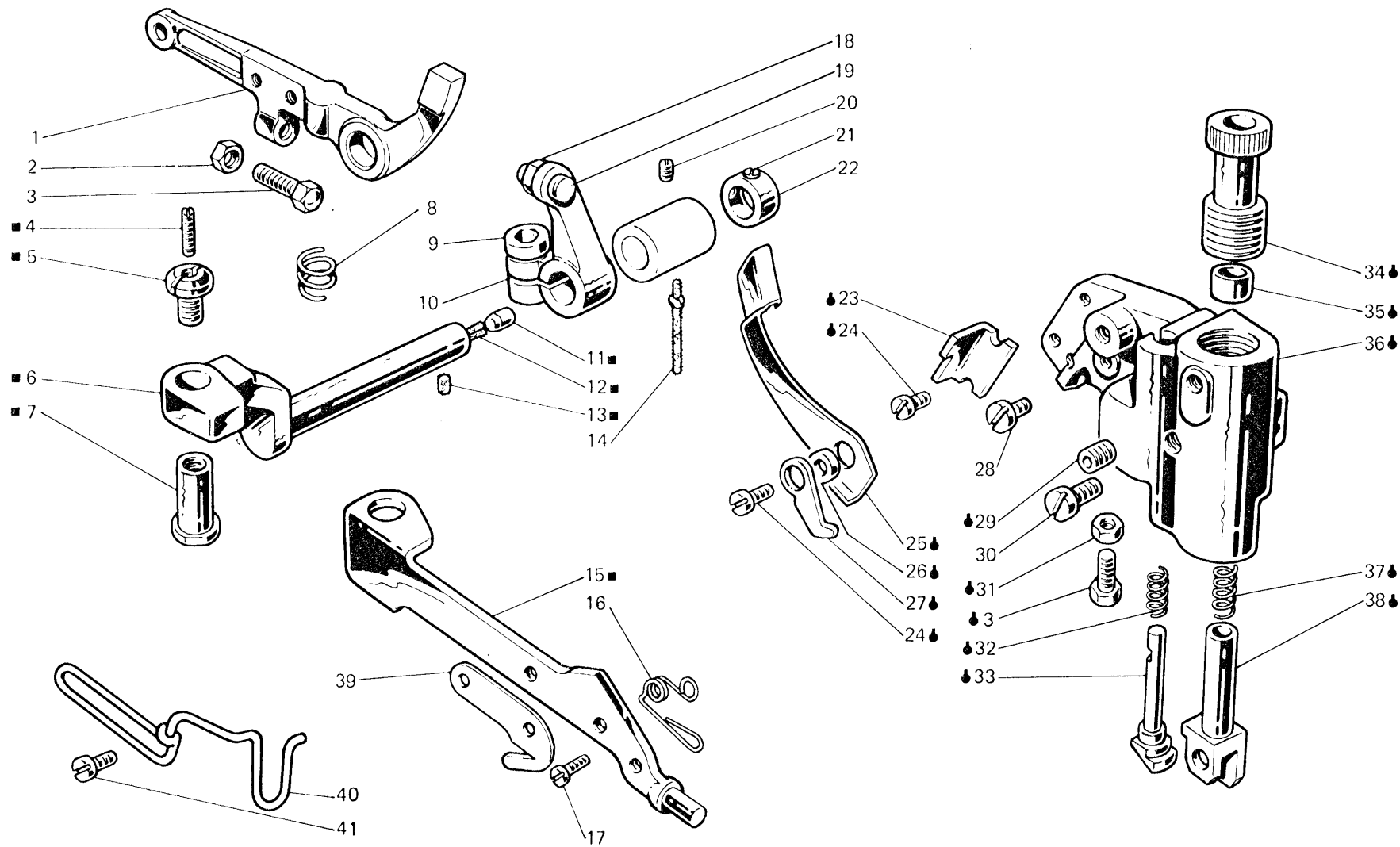

Fig. N. Abb. N.	Part. N. Pieca N. Bestell N. Pieza N.	Qt. Anzahl	DESCRIZIONE	DESCRIPTION	DESCRIPTION	BENENNUNG	DESCRIPCION
◆	206447-4-10	1	gruppo supporto premistoffa	presser support assembly	groupe support pied presseur		
■	206638-4-00	1	leva premistoffa con perno	presser lever	levier du pied presseur		
1	206630-2-01	1	leva alza premistoffa	lever	levier		
2	733505-2-00	1	dado	nut	écrou		
3	202214-0-10	2	vite	screw	vis		
4	729051-2-00	1	vite	screw	vis		
5	202529-0-10	1	perno di fermo	pin	pivot		
6	206626-3-00	1	perno con tappo e stoppini	pin	pivot		
7	206622-0-00	1	spina	pin	goupille		
8	206621-0-00	1	molla rich.leva alza premist.	spring	ressort		
9	744332-2-00	1	vite	screw	vis		
10	206623-2-11	1	leva arresto premist.con viti	lever	levier		
11	301586-0-10	1	pastiglia	plug	bouchon		
12	778520-0-00	1	stoppino	wick	mèche		
13	778203-0-00	1	stoppino	wick	mèche		
14	206620-0-00	1	stoppino buss.perno premistoffa	wick	mèche		
15	206625-0-00	1	leva	lever	levier		
16	204891-0-11	1	molla premi piedino	spring	ressort		
17	203187-0-10	1	vite	screw	vis		
18	746020-2-00	1	dado	nut	écrou		
19	727096-0-00	1	vite	screw	vis		
20	745812-2-00	1	vite	screw	vis		
21	745114-0-00	2	vite	screw	vis		
22	206644-2-00	1	anello con viti	ring	anneau		
23	206639-0-00	1	arresto	stopping	butée		
24	721464-2-00	3	vite	screw	vis		
25	206636-0-00	1	leva	lever	levier		
26	206637-0-00	1	distanziale	spacer	entretoise		
27	206635-0-00	1	nasello	snug	déclic		
28	721494-2-00	1	vite	screw	vis		
29	202391-0-11	1	vite	screw	vis		
30	206642-0-00	1	vite	screw	vis		
31	746007-2-00	1	dado	nut	écrou		
32	202110-0-10	1	molla	spring	ressort		
33	206634-0-00	1	tirante	tie-rod	tirant		
34	206633-0-10	1	vite	screw	vis		
35	206882-0-00	1	distanziale	spacer	entretoise		
36	206640-0-10	1	supporto	support	support		
37	205021-0-10	1	molla	spring	ressort		
38	206632-2-00	1	cannotto	column	fourche		
39	202194-0-10	1	piastrina taglia catenella	chain cutting sheet	plaquette coupe-chainette		
40	990693-0-00	1	salvadita	protection	protection		
41	741453-2-00	2	vite	screw	vis		



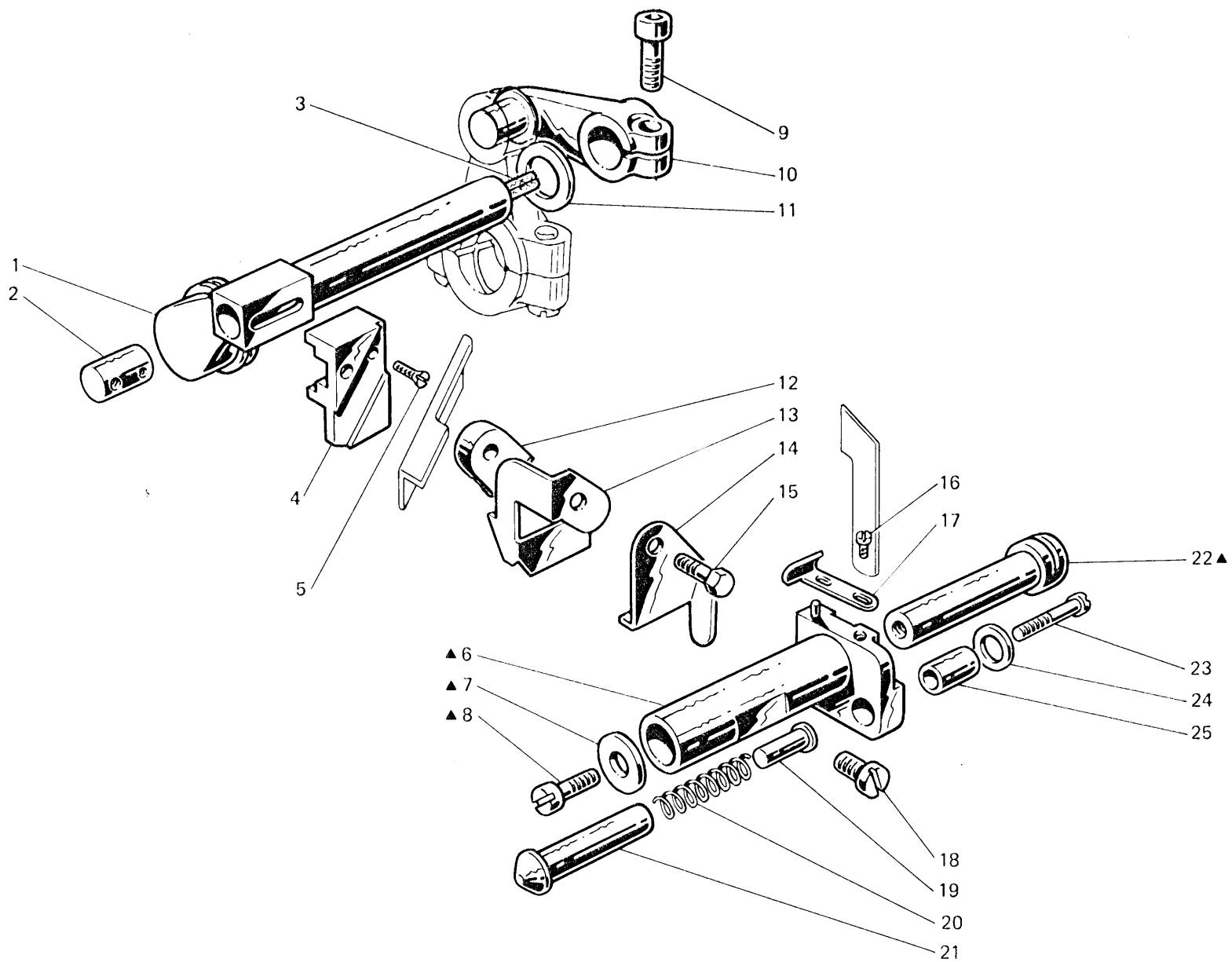

Fig. N. Abb. N.	Part. N. Bestell N. Pieca N. Pieza N.	Qt. Anzahl	DESCRIZIONE	DESCRIPTION	DESCRIPTION	BENENNUNG	DESCRIPCION
▲	204860-4-10	1	gruppo porta coltello inf.	lower knife assembly			groupe porte-couteau inférieur
1	206572-4-00	1	albero colt.sup.con stoppino	upper knife with wick			arbre couteau sup.avec mèche
2	202130-0-11	1	perno	pin			pivot
3	778835-0-00	1	stoppino	wick			mèche
4	204681-0-10	1	placchetta	plate			plaque
5	744573-0-00	1	vite	screw			vis
6	204684-2-11	1	porta coltello inferiore	lower looper holding			porte couteau inférieur
7	704409-0-00	1	rondella	washer			rondelle
8	742457-2-00	1	vite fissa coltello inferiore	screw			vis
9	744334-2-00	1	vite	screw			vis
10	206574-2-00	1	manov.alb.colt.sup.con vite	crank for upper knife shaft			arbre couteau sup.avec vis
11	705029-0-00	1	rondella	washer			rondelle
12	202131-0-10	1	nasello	snug			déclit
13	204699-0-11	1	carterino	cover			carter
14	204691-0-10	1	carterino	cover			carter
15	204799-0-10	1	vite fissa coltello super.	screw			vis
16	741520-0-00	1	vite	screw			vis
17	204690-0-10	1	spingi asola	front needle guard			pare-boucle
18	742758-0-00	1	vite	screw			vis
19	206758-0-00	1	puntalino	pin			pivot
20	202128-0-10	1	molla	spring			ressort
21	206757-0-00	1	bussolina	bush			bague
22	204687-0-10	1	perno	pin			pivot
23	722471-2-00	1	vite	screw			vis
24	704406-0-00	1	rondella	washer			rondelle
25	202129-0-10	1	bussola	bush			bague

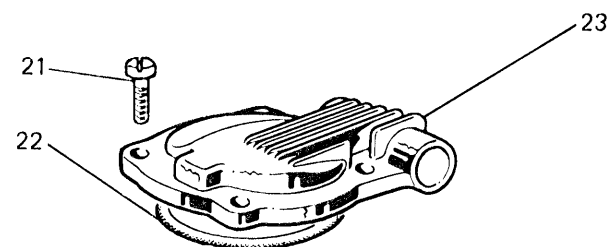
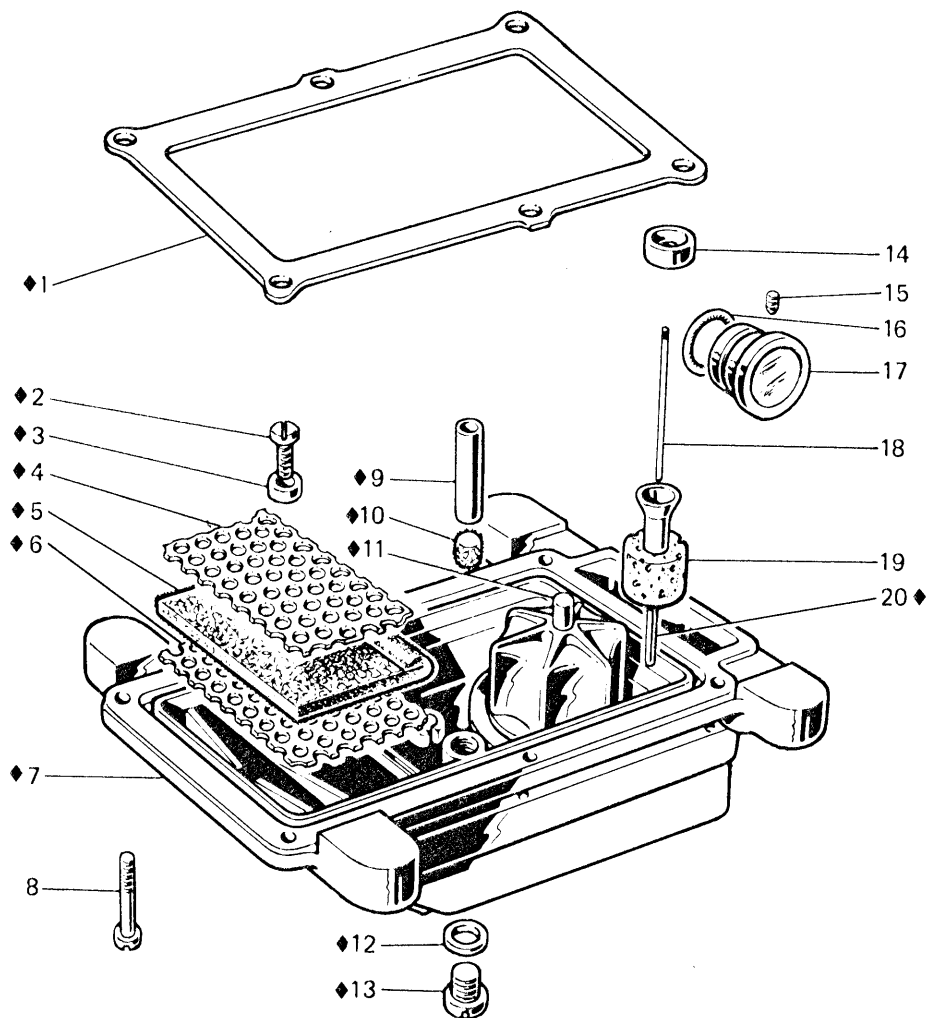

Fig. N. Abb. N.	Part. N. Piece N. Bestell N. Pieza N.	Qt. Anzahl	DESCRIZIONE	DESCRIPTION	DESCRIPTION	BENENNUNG	DESCRIPCION
◆	207490-4-02	1	bacinella olio completa	oil sump assembly	réservoir huile complet		
1	207762-0-00	1	guarnizione bacinella	gasket	garniture		
2	721484-2-00	1	vite	screw	vis		
3	990335-0-10	1	distanziale	spacer	entretoise		
4	206567-0-00	1	lamiera forata superiore	upper sheet	plaque supérieure		
5	206566-0-00	1	filtro	filter	filtre		
6	206565-0-00	1	lamiera forata inferiore	lower sheet	plaque inférieure		
7	207489-3-01	1	bacinella	sump	réservoir		
8	722442-2-00	6	vite	screw	vis		
9	206568-0-01	1	tubetto	tube	tube		
10	206569-0-01	1	filtro	filter	filtre		
11	207499-0-00	1	tappo	plug	bouchon		
12	705977-0-00	1	rondella	washer	rondelle		
13	206564-0-00	1	tappo	plug	bouchon		
14	206667-0-00	1	tappo decompressione	plug	bouchon		
15	745812-2-00	1	vite	screw	vis		
16	701032-0-00	1	anello di tenuta	retainer ring	bague d'étanchéité		
17	207756-0-00	1	indicatore livello olio	oil level gauge	indicateur niveau huile		
18	207757-0-00	1	astina ind. livello olio	stick	tige		
19	206665-2-00	1	galleggiante completo	float assembly	flotteur complet		
20	206662-0-00	1	spina	pin	goupille		
21	722063-2-00	4	vite	screw	vis		
22	701151-0-00	1	anello di tenuta	retainer ring	bague d'étanchéité		
23	207759-2-00	1	coperchio	cover	couvercle		

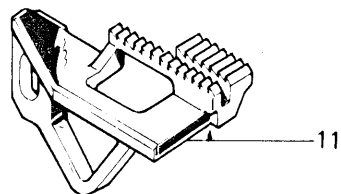
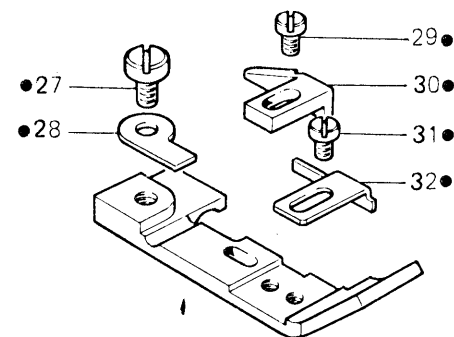
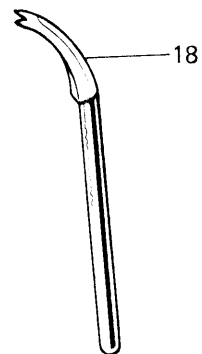
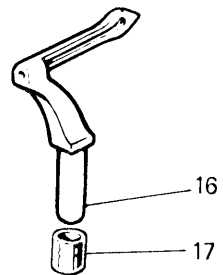
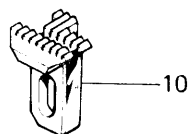
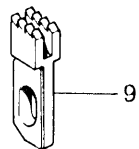
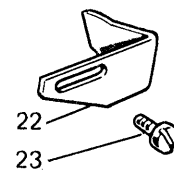
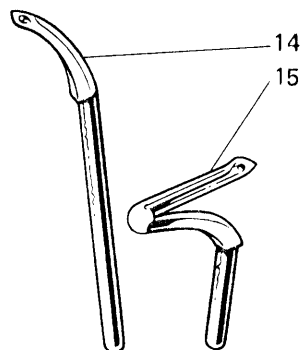
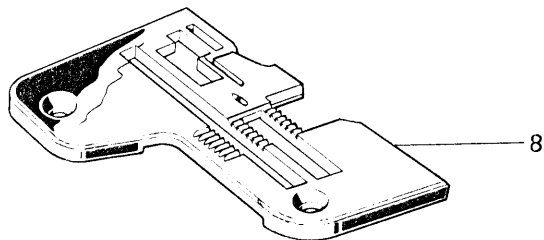
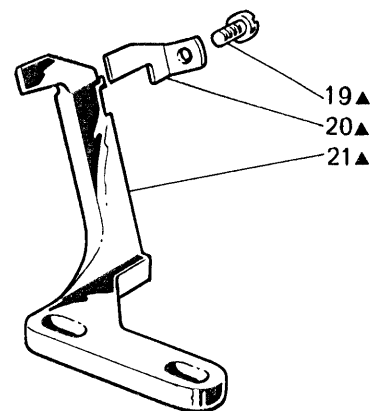
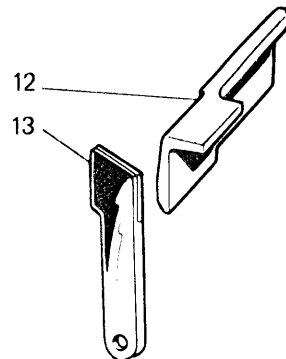
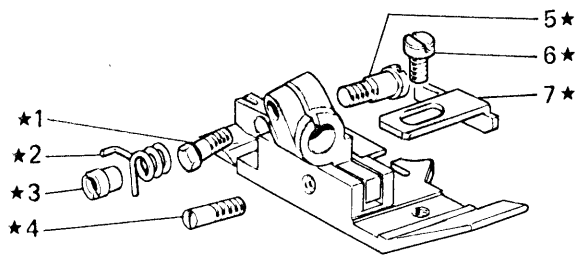

Fig. N. Abb. N.	Part. N. Bestell N. Piece N. Pieza N.	Qt. Anzahl	DESCRIZIONE	DESCRIPTION	DESCRIPTION	BENENNUNG	DESCRIPCION
★	204950-3-12	1	piedino completo	presserfoot assembly	pied-presseur complet		
▲	204862-4-10	1	gruppo spingi asola e salva ago	rear and front needle guard ass.	groupe pare-boucle et protège aiguille		
1	204947-0-10	1	vite	screw	vis		
2	204894-0-11	1	molla	spring	ressort		
3	204895-0-10	1	bussola filettata	bush	bague		
4	204869-0-11	1	spina filettata	pin	goupille		
5	204889-0-10	1	vite	screw	vis		
6	741413-2-00	1	vite	screw	vis		
7	204878-0-11	1	piastrina	plate	plaque		
8	204695-0-11	1	placca ago larg. costa 3,5 mm	needle plate width bight 3.5 mm	plaque à aiguille larg. surjet 3,5 mm		
9	202609-0-10	1	griffino	chaining feed dog	petite griffe		
10	204668-0-10	1	griffa sussidiaria	subsidiary feed dog	griffe subsidiaire		
11	204666-0-10	1	griffa principale	main feed dog	griffe principale		
12	203783-0-10	2	coltello superiore	upper knife	couteau supérieur		
13	204693-0-11	2	coltello inferiore	lower knife	couteau inférieur		
14	204033-0-10	1	crochet superiore	upper looper	crochet supérieur		
15	202413-0-11	1	crochet inferiore	lower looper	crochet inférieur		
16	204676-0-11	1	crochet punto sicurezza	looper safety stitch	crochet point de sûreté		
17	204912-0-10	1	distanziale	spacer	entretoise		
18	202092-0-00	1	crochet superiore cieco	upper blind looper	crochet supérieur aveugle		
19	741431-0-00	1	vite	screw	vis		
20	204863-0-10	1	salva ago	rear needle guard	protège aiguille		
21	204861-0-10	1	spingi asola	front needle guard	pare-boucle		
22	204905-0-10	1	squadretta	bracket	équerre		
23	721443-2-00	1	vite	screw	vis		
			SOLO A RICHIESTA	ONLY ON REQUEST	SEULEMENT SUR DEMANDE		
●	206482-3-00	1	piedino completo	presserfoot assembly	pied-presseur complet		
8	204696-0-10	1	placca ago larg. costa 4,2 mm	needle plate width bight 4.2 mm	plaque à aiguille larg. surjet 4,2 mm		
	204809-0-00	1	placca ago larg. costa 5,5 mm	needle plate width bight 5.5 mm	plaque à aiguille larg. surjet 5,5 mm		
10	204808-2-11	1	griffa sussidiaria	subsidiary feed dog	griffe subsidiaire		
	204999-0-00	1	griffa sussidiaria	subsidiary feed dog	griffe subsidiaire		
	205536-0-00	1	griffa sussidiaria	subsidiary feed dog	griffe subsidiaire		
11	204806-2-11	1	griffa principale	main feed dog	griffe principale		
	204998-0-00	1	griffa principale	main feed dog	griffe principale		
	205537-0-00	1	griffa principale	main feed dog	griffe principale		
12	203759-0-10	1	coltello superiore	upper knife	couteau supérieur		
24	743134-0-00	1	vite	screw	vis		
25	206641-2-00	1	attacco con vite	coupling with screw	raccord avec vis		
26	206486-0-00	1	molla	spring	ressort		
27	741665-2-00	1	vite	screw	vis		
28	202201-0-11	1	staffa	bracket	bride		
29	741453-2-00	1	vite	screw	vis		
30	206483-0-00	1	linguetta	tongue	languette		
31	741433-2-00	1	vite	screw	vis		
32	206484-0-00	1	piastrina	plate	plaque		

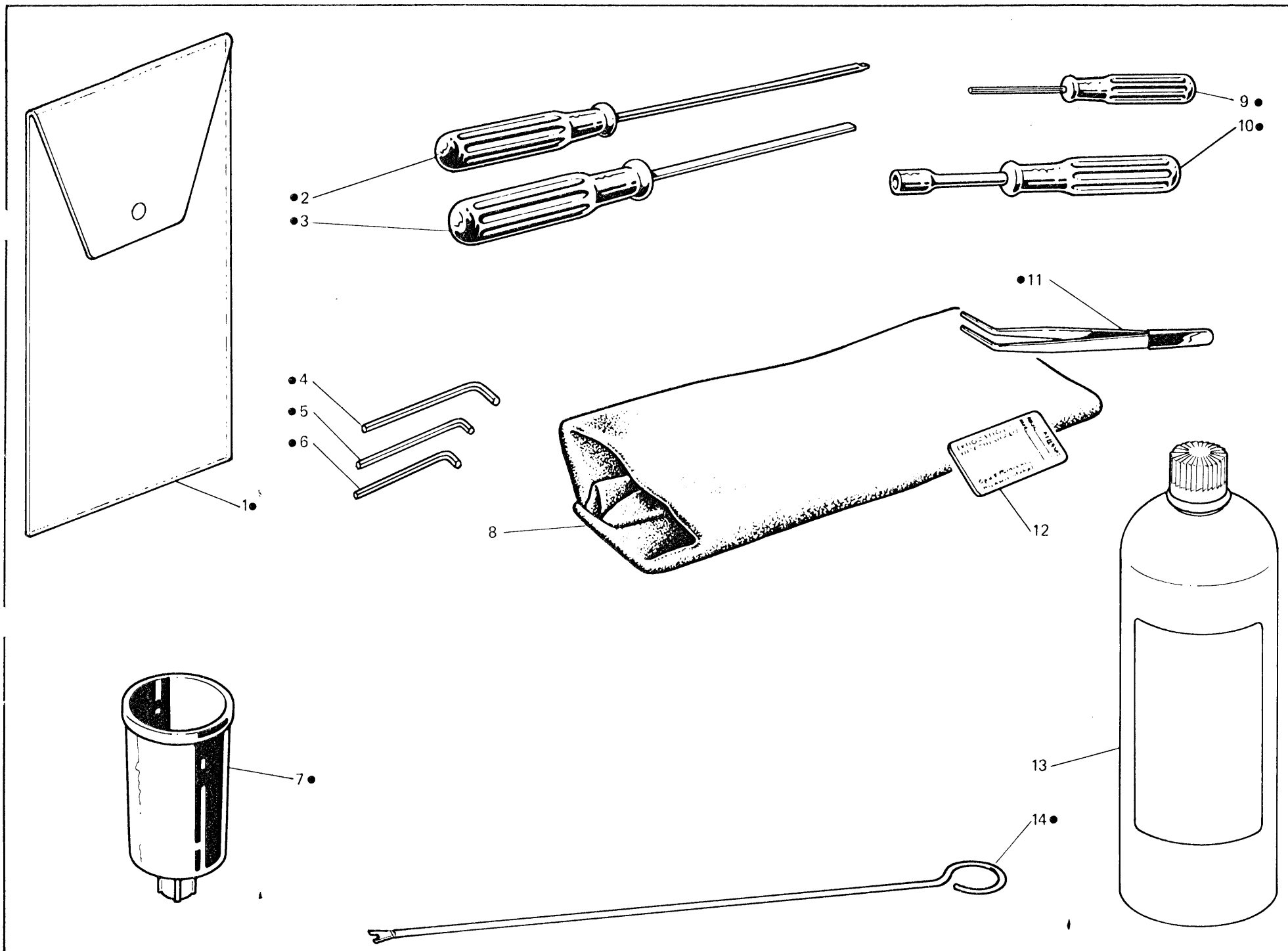

Fig. N. Abb. N.	Part. N. Piec. N. Bestell N. Pieza N.	Qt. Anzahl	DESCRIZIONE	DESCRIPTION	DESCRIPTION	BENENNUNG	DESCRIPCION
●	991401-4-00	1	busta accessori completa	accessories envelope assembly	envelope accessoires complète		
1	991415-0-00	1	busta accessori	accessories envelope	envelope accessoires		
2	990180-0-10	1	cacciavite grande	screw driver	gros tournevis		
3	990181-0-10	1	cacciavite medio	screw driver	tournevis moyen		
4	990639-0-10	1	chiave esagonale da 3 mm.	3 mm hexagonal key	clé hexagonale de 3 mm		
5	990685-0-10	1	chiave esagonale da 2,5 mm.	2,5 mm hexagonal key	clé hexagonale de 2,5 mm.		
6	990325-0-10	1	chiave esagonale da 2 mm.	2 mm hexagonal key	clé hexagonale de 2 mm		
7	990985-0-00	1	imbuto	oil funnel	entenoir		
8	990183-0-12	1	cuffia protezione testa	machine cover	couverture protection tête		
9	990474-0-11	1	chiave esagonale da 1,5 mm	1,5 mm hexagonal key	clé hexagonale de 1,5 mm		
10	990324-0-10	1	chiave a tubo da 7 mm	7 mm key	clé de 7 mm		
11	990176-0-10	1	pinza per infilatura	threading clers	pince pour enfilage		
12	★	1	bustina aghi	needles packet	paquet aiguilles		
13	990075-1-13	1	lattina olio da 1 Kg.	oil container (1 Kg)	bidon huile de 1 Kg		
14	990577-0-10	1	astina per infilatura	threading rod	tige pour enfilage		
			★per l'ordinazione della bustina citare lo stesso simbolo dell'ago montato sulla testa	★to order packet of needles please specify symbol of needle fitted on machine	★pour commander un sachet d'aiguille donner le symbol de l'aiguille montée sur la tête		



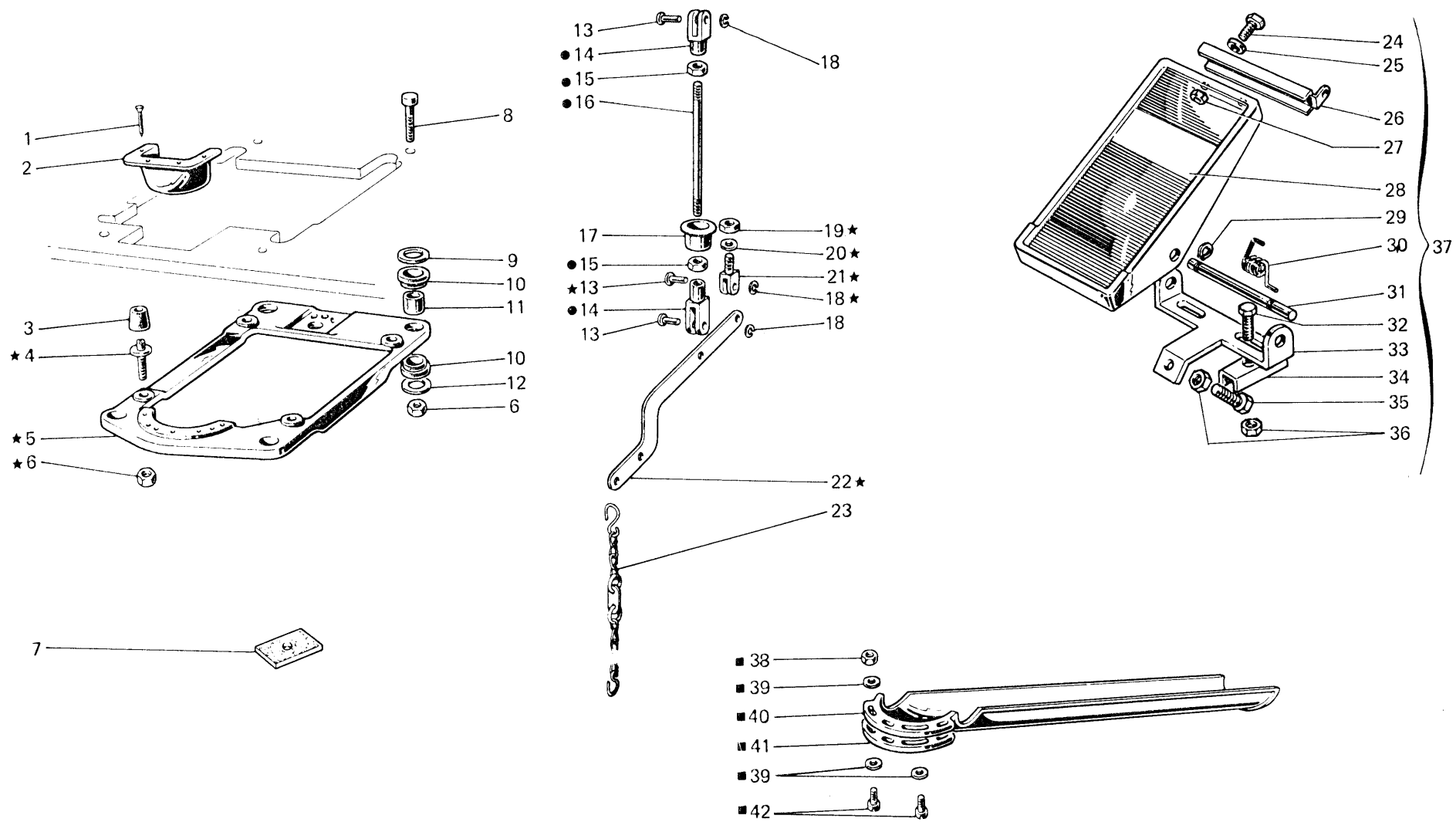

Fig. N. Abb. N.	Part. N. Bestell N. Piece N. Pieza N.	Qt. Anzahl	DESCRIZIONE	DESCRIPTION	DESCRIPTION	BENENNUNG	DESCRIPCION
			<b>PIAZZAMENTO NORMALE</b>	<b>NORMAL SETTING</b>	<b>INSTALLATION NORMAL</b>		
★	990986-4-00	1	supporto testa completo	head support assembly	support tête complet		
●	990984-4-00	1	tirante alza piedino completo	presser tie rod assembly	tirant pour soulèvement pied-presseur		
1	900201-0-10	4	chiodino	rivet	clou		
2	991187-0-00	1	bocchetta	cup	bouche		
3	990982-0-00	4	ammortizzatore	shock absorber	amortisseur		
4	900694-0-11	4	perno	pin	pivot		
5	990981-0-00	1	supporto testa	head support	support tête		
6	733008-2-00	8	dado	nut	écrou		
7	900203-0-10	4	ammortizzatori per tavola	shock absorber	amortisseur		
8	722905-2-00	4	vite	screw	vis		
9	704346-2-00	4	rondella	washer	rondelle		
10	901101-0-00	8	ammortizzatore	shock absorber	amortisseur		
11	901102-0-00	4	distanziale	spacer	entretoise		
12	704345-2-00	4	rondella	washer	rondelle		
13	990311-0-10	3	perno	pin	pivot		
14	990310-0-10	2	giunto	joint	joint		
15	746402-2-00	2	dado	nut	écrou		
16	990983-0-00	1	tirante	tie-rod	tirant		
17	900204-0-10	1	bussola	bush	bague		
18	700205-0-00	3	anello elastico	spring ring	anneau ressort		
19	746409-2-00	1	dado	nut	écrou		
20	704424-2-00	1	rondella	washer	rondelle		
21	990314-0-10	1	supportino	support	support		
22	990316-0-10	1	leva	lever	levier		
23	990179-4-11	1	catenella completa	chain assembly	chainette complète		
24	720464-4-00	2	vite	screw	vis		
25	704009-4-00	2	rondella	washer	rondelle		
26	900926-0-00	1	attacco	coupling	raccord		
27	733508-4-00	2	dado	nut	écrou		
28	900931-0-00	1	copertura	covering	couverture		
29	900918-0-00	2	anello elastico	spring ring	anneau ressort		
30	900927-0-00	1	molla	spring	ressort		
31	900928-0-00	1	perno	pin	pivot		
32	720505-4-00	2	vite	screw	vis		
33	900929-0-01	1	supporto	support	support		
34	900920-0-00	2	piastrina	plate	plaque		
35	720545-4-00	1	vite	screw	vis		
36	733510-4-00	3	dado	nut	écrou		
37	900925-4-01	1	pedalina completa	pedal assembly	pédale complète		
			<b>SOLO A RICHIESTA</b>	<b>ONLY ON REQUEST</b>	<b>SEULEMENT SUR DEMANDE</b>		
■	991186-1-00	1	gruppo canale scarico ritagli	offlet assembly	groupe décharge chutes		
38	733507-2-00	1	dado	nut	écrou		
39	704409-2-00	4	rondella	washer	rondelle		
40	991186-0-00	1	canale scarico ritagli	offlet	décharge chutes		
41	991189-0-00	1	piastra di rinforzo	plate	plaque		
42	742068-2-00	3	vite	screw	vis		

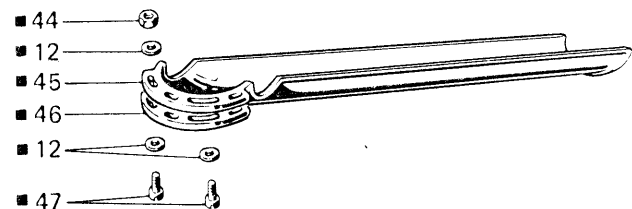
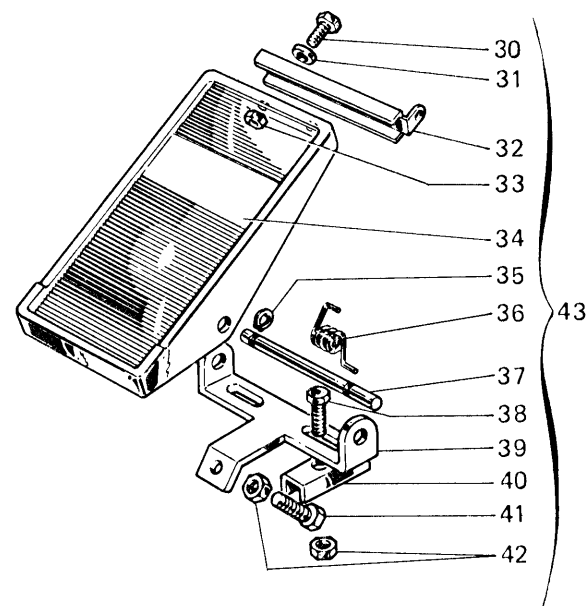
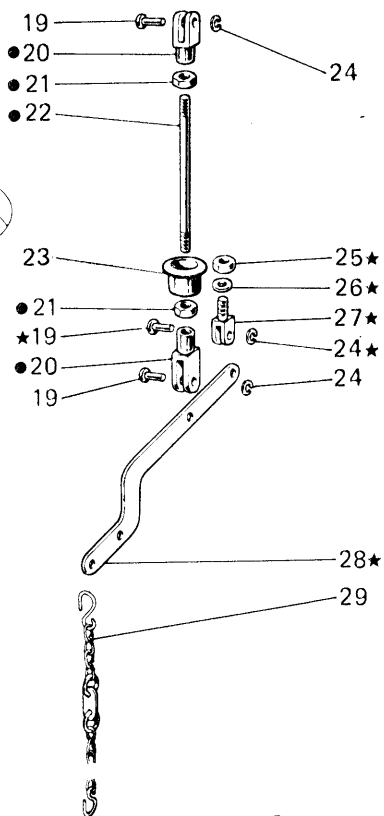
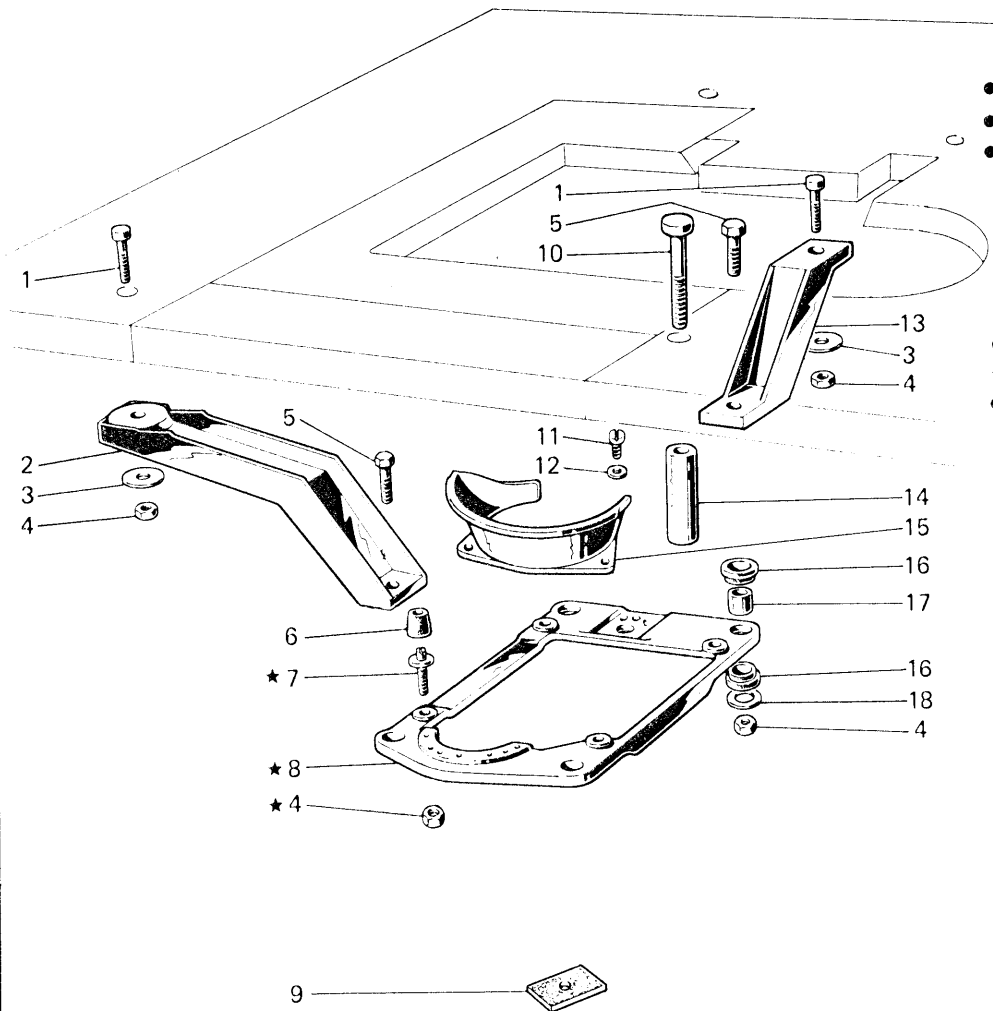

Fig. N. Abb. N.	Part. N. Bestell N. Piece N. Pieza N.	Qt. Anzahl	DESCRIZIONE	DESCRIPTION	DESCRIPTION	BENENNUNG	DESCRIPCION
			<b>PIAZZAMENTO INCASSATO</b>	<b>SUBMERGED SETTING</b>	<b>INSTALLATION ENCASTREE</b>		
★	990986-4-00	1	supporto testa completo	head support assembly	support tête complet		
●	990984-4-00	1	tirante alza piedino completo	presser tie-rod assembly	tirant pour soulèvement pied presseur		
1	722905-2-00	2	vite	screw	vis		
2	901105-0-00	1	staffa laterale	bracket	bride		
3	704536-0-00	2	rondella	washer	rondelle		
4	733008-2-00	6	dado	nut	écrou		
5	720566-2-00	2	vite	screw	vis		
6	990982-0-00	4	ammortizzatore	shock absorber	amortisseur		
7	900694-0-11	4	perno	pin	pivot		
8	990981-0-00	1	supporto testa	head support	support tête		
9	900203-0-10	4	ammortizzatore per tavola	shock absorber	amortisseur		
10	722917-2-00	2	vite	screw	vis		
11	721475-2-00	2	vite	screw	vis		
12	704409-2-00	2	rondella	washer	rondelle		
13	901104-0-00	1	staffa posteriore	bracket	bride		
14	901103-0-10	2	distanziale	spacer	entretoise		
15	991188-0-00	1	bocchetta	cup	bouche		
16	901101-0-00	8	ammortizzatore	shock absorber	amortisseur		
17	901102-0-00	4	distanziale	spacer	entretoise		
18	704345-2-00	4	rondella	washer	rondelle		
19	990311-0-10	3	perno	pin	pivot		
20	990310-0-10	2	giunto	joint	joint		
21	746402-2-00	2	dado	nut	écrou		
22	990983-0-00	1	tirante	tie-rod	tirante		
23	900204-0-10	1	bussola	bush	bague		
24	700205-0-00	3	anello elastico	spring ring	anneau ressort		
25	746409-2-00	1	dado	nut	écrou		
26	704424-2-00	1	rondella	washer	rondelle		
27	990314-0-10	1	supportino	support	support		
28	990316-0-10	1	leva	lever	levier		
29	990179-4-11	1	catenella completa	chain assembly	chaînette complète		
30	720464-4-00	2	vite	screw	vis		
31	704009-4-00	2	rondella	washer	rondelle		
32	900926-0-00	1	attacco	coupling	raccord		
33	733508-4-00	2	dado	nut	écrou		
34	900931-0-00	1	copertura	covering	couverture		
35	900918-0-00	2	anello elastico	spring ring	anneau ressort		
36	900927-0-00	1	molla	spring	ressort		
37	900928-0-00	1	perno	pin	pivot		
38	720505-4-00	2	vite	screw	vis		
39	900929-0-01	1	supporto	support	support		
40	900920-0-00	2	piatrina	plate	plaque		
41	720545-4-00	1	vite	screw	vis		
42	733510-4-00	3	dado	nut	écrou		
43	900925-4-01	1	pedalina completa	pedal assembly	pédale complète		
			<b>SOLO A RICHIESTA</b>	<b>ONLY ON REQUEST</b>	<b>SEULEMENT SUR DEMANDE</b>		
■	991186-1-00	1	gruppo canale scarica ritagli	offlet assembly	groupe décharge chutes		

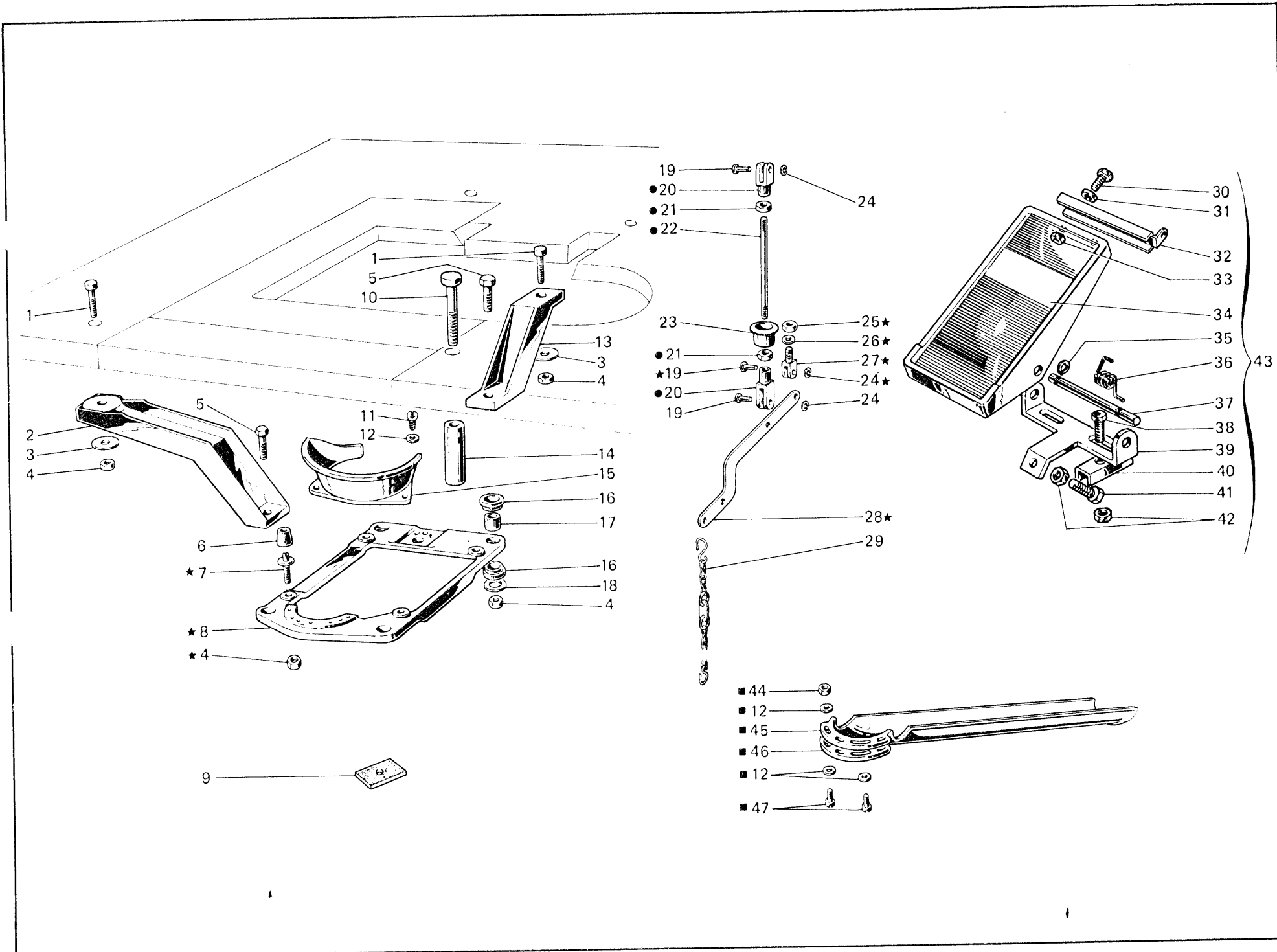

Fig. N. Abb. N.	Part. N. Bestell N. Piece N. Pieza N.	Qt. Anzahl	DESCRIZIONE	DESCRIPTION	DESCRIPTION	BENENNUNG	DESCRIPCION
12	704409-2-00	4	rondella	washer	rondelle		
44	733507-2-00	1	dado	nut	écrou		
45	991186-0-00	1	canale scarico ritagli	offlet	décharge chutes		
46	991189-0-00	1	piastra di rinforzo	plate	plaque		
47	742068-2-00	3	vite	screw	vis		

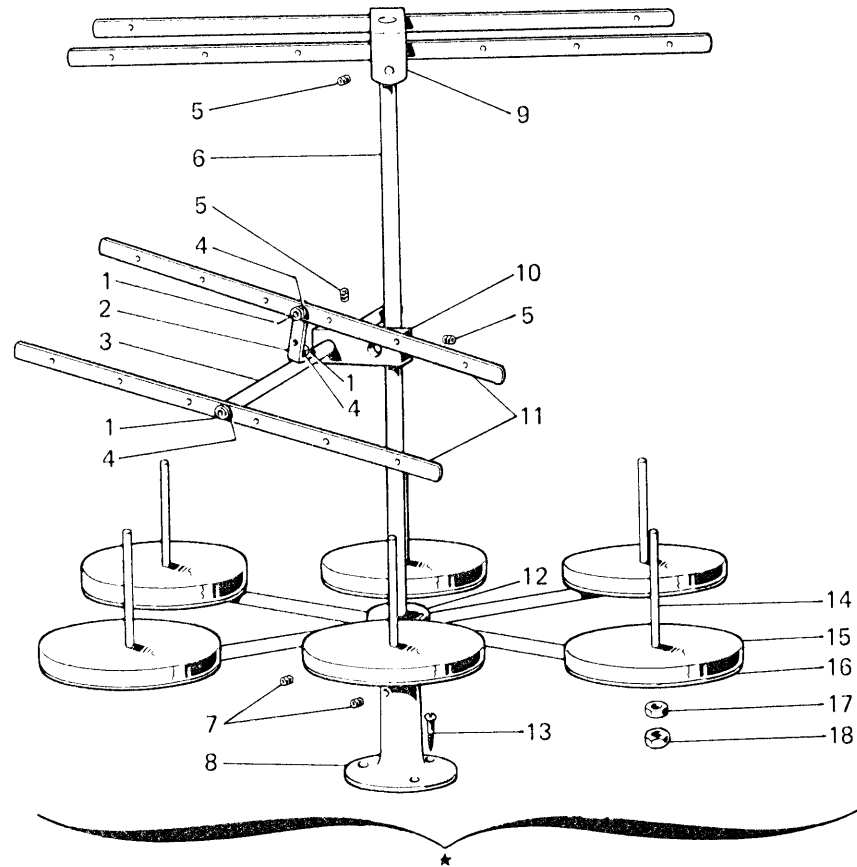

Fig. N. Abb. N.	Part. N. Pezce N. Bestell N. Pieza N.	Qt. Anzahl	DESCRIZIONE	DESCRIPTION	DESCRIPTION	BENENNUNG	DESCRIPCION
★	991135-5-00	1	porta bobine compl. (5-6 fili)	bobbin carrier ass. (5-6 threads)	porte bobine compl. (5-6 fils)		
1	722431-2-00	3	vite	screw	vis		
2	991107-2-00	1	squadretta	bracket	équerre		
3	991106-2-00	1	asta	rod	tige		
4	703005-0-00	3	rondella	washer	rondelle		
5	729034-2-00	3	vite	screw	vis		
6	991113-0-00	1	asta principale	main rod	tige principale		
7	729054-2-00	3	vite	screw	vis		
8	991114-2-00	1	basetta con vite	base with screw	base avec vis		
9	991139-3-00	1	telaio sup.completo	upper frame assembly	bâti supérieur complet		
10	991128-2-00	1	blocchetto	block	bloc		
11	991137-2-00	2	telaio con bussole	frame with bush	bâti avec bague		
12	991144-3-00	1	mozzo con aste	hub with rods	moyeu avec tiges		
13	731107-2-00	3	vite da legno	screw	vis		
14	991111-2-00	6	astina	rod	tige		
15	991179-0-00	6	disco	disc	disque		
16	991112-0-00	6	piatto	disc	plateau		
17	733508-2-00	6	dado	nut	écrou		
18	925433-0-00	6	dado	nut	écrou		



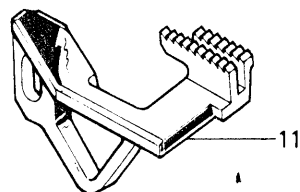
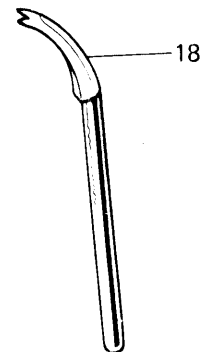
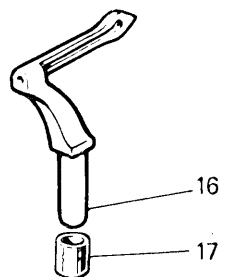
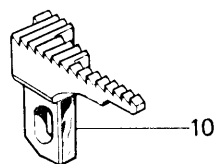
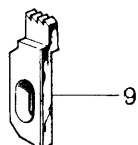
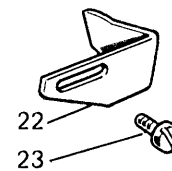
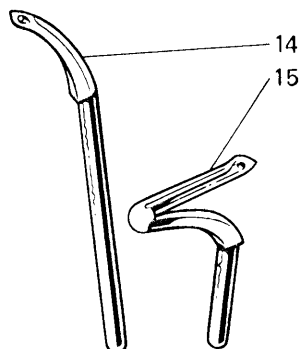
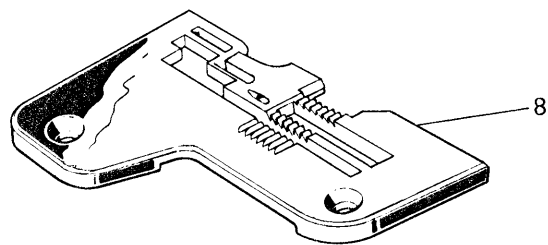
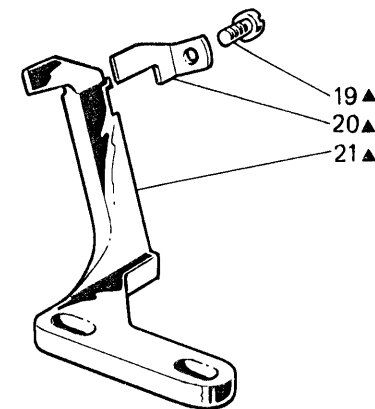
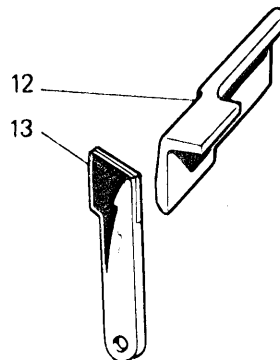
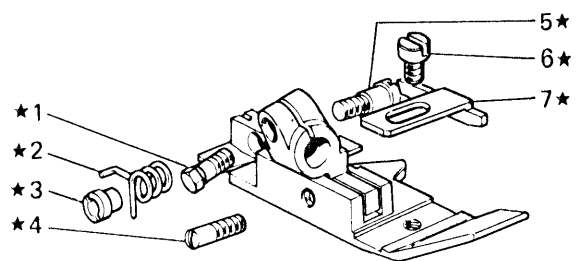

Fig. N. Abb. N.	Part. N. Bestell N. Piecce N. Pieza N.	Qt. Anzahl	DESCRIZIONE	DESCRIPTION	DESCRIPTION	BENENNUNG	DESCRIPCION
★	204706-3-12	1	piedino completo	presserfoot assembly	pied-presseur complet		
▲	204862-4-10	1	gruppo spingi asola e salva ago	rear and front needle guard ass.	groupe pare-boucle et protège aiguille		
1	204947-0-10	1	vite	screw	vis		
2	204894-0-11	1	molla	spring	ressort		
3	204895-0-10	1	bussola filettata	bush	bague		
4	204869-0-11	1	spina filettata	pin	goupille		
5	204889-0-10	1	vite	screw	vis		
6	741413-2-00	1	vite	screw	vis		
7	204878-0-11	1	piastrina	plate	plaque		
8	204698-0-11	1	placca ago larg. costa 3,7 mm	needle plate width bight 3.7 mm	plaque à aiguille larg. surjet 3,7 mm		
9	204819-0-10	1	griffino	chaining feed dog	petite griffe		
10	204669-0-10	1	griffa sussidiaria	subsidiary feed dog	griffe subsidiaire		
11	204667-0-10	1	griffa principale	main feed dog	griffe principale		
12	203783-0-10	2	coltello superiore	upper knife	couteau supérieur		
13	204693-0-11	2	coltello inferiore	lower knife	couteau inférieur		
14	204033-0-10	1	crochet superiore	upper looper	crochet supérieur		
15	202413-0-11	1	crochet inferiore	lower looper	crochet inférieur		
16	204676-0-11	1	crochet punto sicurezza	looper safety stitch	crochet point de sûreté		
17	204912-0-10	1	distanziale	spacer	entretoise		
18	202092-0-10	1	crochet sup. cieco	upper blind looper	crochet sup. aveugle		
19	741431-0-00	1	vite	screw	vis		
20	204863-0-10	1	salva ago	rear needle guard	protège-aiguille		
21	204861-0-10	1	spingi asola	front needle guard	pare-boucle		
22	204905-0-10	1	squadretta	bracket	équerre		
23	721443-2-00	1	vite	screw	vis		
			SOLO A RICHIESTA	ONLY ON REQUEST	SEULEMENT SUR DEMANDE		
8	204692-0-00	1	placca ago larg. costa 4 mm	needle plate width bight 4 mm	plaque à aiguille larg. surjet 4 mm		
	206866-0-00	1	placca ago larg. costa 5 mm	needle plate width bight 5 mm	plaque à aiguille larg. surjet 5 mm		
10	205065-0-10	1	griffa sussidiaria	subsidiary feed dog	griffe subsidiaire		
12	203759-0-10	1	coltello superiore	upper knife	couteau supérieur		

**VARIANTE PER**

**VARIATION FOR**

**VARIANTE POUR**

129-00-2CD-06

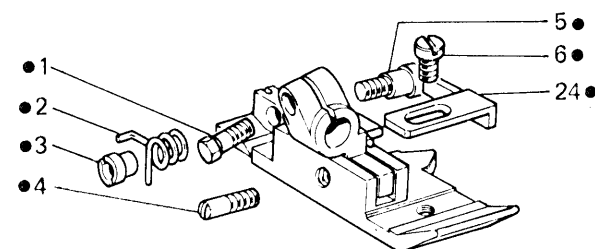
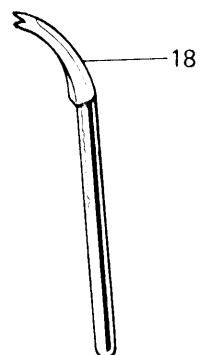
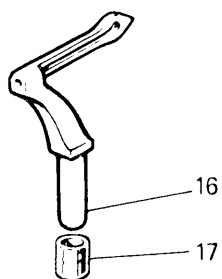
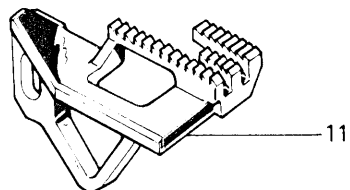
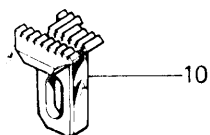
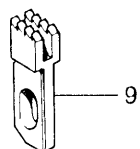
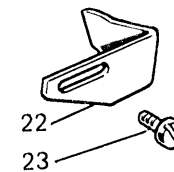
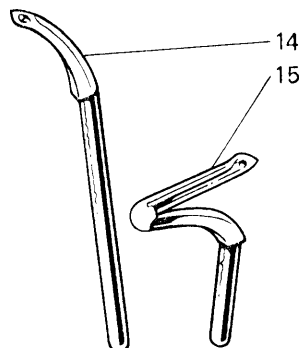
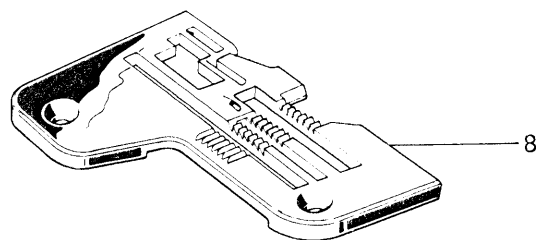
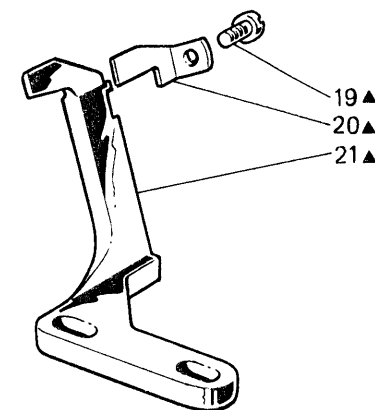
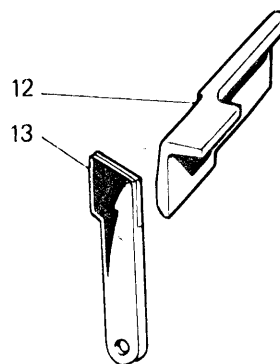
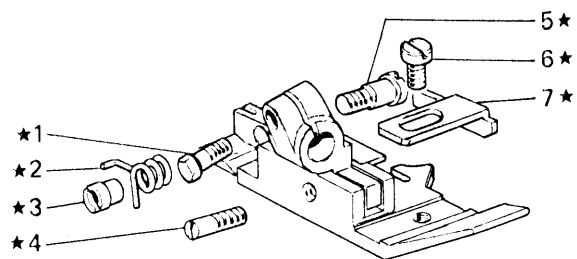

Fig. N. Abb. N.	Part. N. Piecce N. Bestell N. Pieza N.	Qt. Anzahl	DESCRIZIONE	DESCRIPTION	DESCRIPTION	BENENNUNG	DESCRIPCION
★	205070-3-12	1	pedino completo	presserfoot assembly	pied-presseur complet		
▲	204862-4-10	1	gruppo spingi asola e salva ago	rear and front needle guard	groupe pare-boucle et protège aiguille		
1	204947-0-10	1	vite	screw	vis		
2	204894-0-11	1	molla	spring	ressort		
3	204895-0-10	1	bussola filettata	bush	bague		
4	204869-0-11	1	spina filettata	pin	goupille		
5	204889-0-10	1	vite	screw	vis		
6	741413-2-00	1	vite	screw	vis		
7	204878-0-11	1	piastrina	plate	plaque		
8	205025-0-10	1	placca ago larg. costa 5,5 mm	needle plate width bight 5.5 mm	plaque à aiguille larg. surjet 5,5 mm		
9	202609-0-10	1	griffino	chaining feed dog	petite griffe		
10	205011-0-10	1	griffa sussidiaria	subsidiary feed dog	griffe subsidiaire		
11	205007-0-10	1	griffa principale	main feed dog	griffe principale		
12	203783-0-10	2	coltello superiore	upper knife	couteau supérieur		
13	204693-0-11	2	coltello inferiore	lower knife	couteau inférieur		
14	204033-0-10	1	crochet superiore	upper looper	crochet supérieur		
15	202413-0-11	1	crochet inferiore	lower looper	crochet inférieur		
16	204676-0-11	1	crochet punto sicurezza	looper safety stitch	crochet point de sûreté		
17	205125-0-00	1	distanziale	spacer	entretoise		
18	202092-0-10	1	crochet superiore cieco	upper blind looper	crochet supérieur aveugle		
19	741431-0-00	1	vite	screw	vis		
20	204863-0-10	1	salva ago	rear needle guard	protège aiguille		
21	204861-0-10	1	spingi asola	front needle guard	pare-boucle		
22	204905-0-10	1	squadretta	bracket	équerre		
23	721443-2-00	1	vite	screw	vis		
			SOLO A RICHIESTA	ONLY ON REQUEST	SEULEMENT SUR DEMANDE		
●	207055-3-01	1	pedino completo	presserfoot assembly	pied-presseur complet		
8	207051-0-00	1	placca ago larg. costa 2 mm	needle plate width bight 2 mm	plaque à aiguille larg. surjet 2 mm		
10	205013-2-11	1	griffa sussidiaria	subsidiary feed dog	griffe subsidiaire		
	205064-0-10	1	griffa sussidiaria	subsidiary feed dog	griffe subsidiaire		
	205065-0-10	1	griffa sussidiaria	subsidiary feed dog	griffe subsidiaire		
11	205009-2-11	1	griffa principale	main feed dog	griffe principale		
	205059-0-10	1	griffa principale	main feed dog	griffe principale		
	205060-0-10	1	griffa principale	main feed dog	griffe principale		
	207052-0-00	1	griffa principale	main feed dog	griffe principale		
12	203759-0-10	1	coltello superiore	upper knife	couteau supérieur		
24	207053-0-01	1	piastrina	plate	plaque		

Fig. N. Abb. N.	Part. N. Bestell N. Piece N. Pieza N.	Qt. Anzahl	DESCRIZIONE	DESCRIPTION	DESCRIPTION	BENENNUNG	DESCRIPCION
	<u>Tav. 4</u>						
1	207552-4-00	1	pressafilo completo	thread presser assembly	presse-fil complet		
5	203635-0-10	3	pastiglia	plug	bouchon		
16	205052-2-12	1	passafilo per ago	thread guide	passe fil		
	<u>Tav. 10</u>						
★	207500-4-00	1	cinematismo comando aghi	needles control assembly	cinématisme comm. aiguilles		
▲	207516-4-00	1	morsetto porta aghi compl.	needles clamp assembly	porte-aiguilles complet		
4	206515-0-01	1	leva	lever	levier		
28	207526-2-00	1	morsetto porta aghi	needles clamp	porte-aiguilles		
30	765200-6-10	1	ago Rim 27 fin. 100	needle Rim 27 size 100	aiguille Rim 27 jauge 100		
41	765500-6-10	1	ago Rim 29 fin. 100 punta sei	needle Rim 29 size 100	aiguille Rim 29 jauge 100		
	<u>Tav. 11</u>						
16	205042-0-11	1	molla premi piedino	spring	ressort		
	<u>Tav. 12</u>						
17	205024-0-10	1	spingi asola	front needle guard	pare-boucle		

**VARIANTE PER**

**VARIATION FOR**

**VARIANTE POUR**

129-00-2CD-10

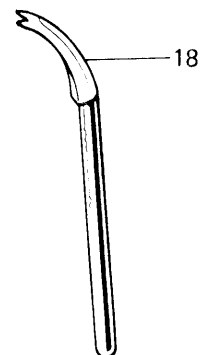
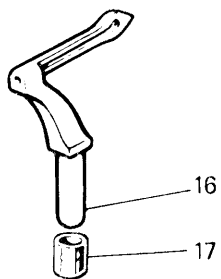
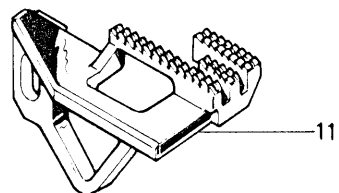
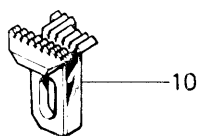
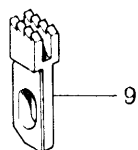
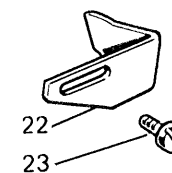
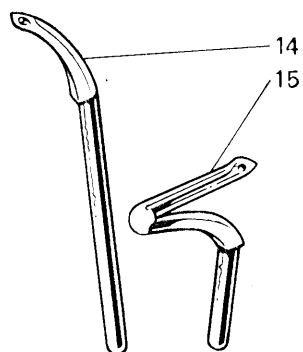
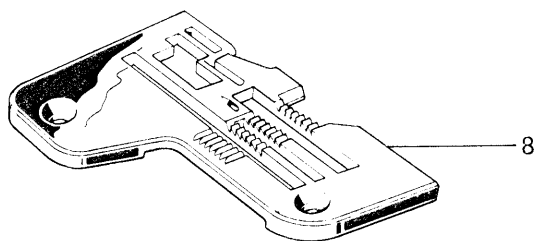
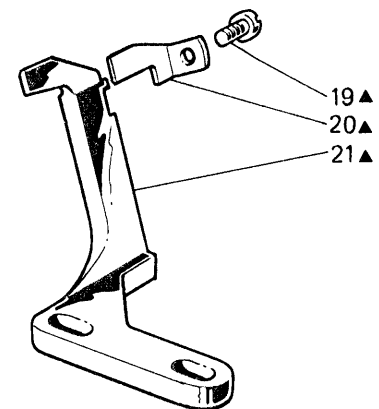
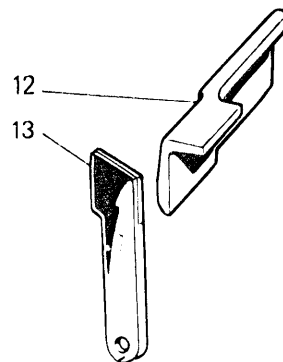
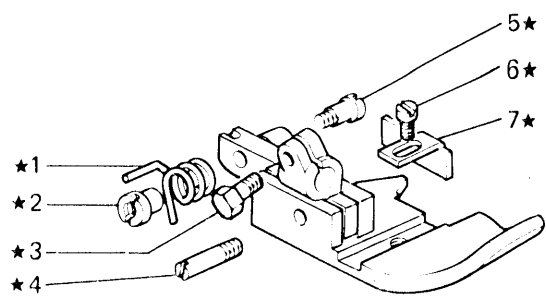



Fig. N. Abb. N.	Part. N. Bestell N. Piece N. Pieza N.	Qt. Anzahl	DESCRIZIONE	DESCRIPTION	DESCRIPTION	BENENNUNG	DESCRIPCION
★	205118-3-12	1	piedino completo	presserfoot assembly	pied-presseur complet		
▲	204862-4-10	1	gruppo spingi asola e salva ago	rear and front needle guard ass.	groupe pare-boucle et protège-aiguille		
1	204894-0-11	1	molla	spring	ressort		
2	204895-0-10	1	bussola filettata	bush	bague		
3	204947-0-10	1	vite	screw	vis		
4	204869-0-11	1	spina filettata	pin	goupille		
5	204889-0-10	1	vite	screw	vis		
6	741413-2-00	1	vite	screw	vis		
7	204878-0-11	1	piastrina	plate	plaque		
8	205025-0-10	1	placca ago larg. costa 5,5 mm	needle plate width bight 5.5 mm	plaque à aiguille larg. surjet 5,5 mm		
9	202609-0-10	1	griffino	chaining feed dog	petite griffe		
10	205065-0-10	1	griffa sussidiaria	subsidiary feed dog	griffe subsidiaire		
11	205060-0-10	1	griffa principale	main feed dog	griffe principale		
12	203759-0-10	2	coltello superiore	upper knife	couteau supérieur		
13	204693-0-11	2	coltello inferiore	lower knife	couteau inférieur		
14	204033-0-10	1	crochet superiore	upper looper	crochet supérieur		
15	202413-0-11	1	crochet inferiore	lower looper	crochet inférieur		
16	204676-0-11	1	crochet punto sicurezza	looper safety stitch	crochet point de sûreté		
17	205125-0-00	1	distanziale	spacer	entretoise		
18	202092-0-10	1	crochet superiore cieco	upper blind looper	crochet supérieur aveugle		
19	741431-0-00	1	vite	screw	vis		
20	204863-0-10	1	salva ago	rear needle guard	protège-aiguille		
21	204861-0-10	1	spingi asola	front needle guard	pare-boucle		
22	204905-0-10	1	squadretta	bracket	équerre		
23	721443-2-00	1	vite	screw	vis		
			SOLO A RICHIESTA	ONLY ON REQUEST	SEULEMENT SUR DEMANDE		
10	205011-0-10	1	griffa sussidiaria	subsidiary feed dog	griffe subsidiaire		
	205013-2-11	1	griffa sussidiaria	subsidiary feed dog	griffe subsidiaire		
	205064-0-10	1	griffa sussidiaria	subsidiary feed dog	griffe subsidiaire		
11	205007-0-10	1	griffa principale	main feed dog	griffe principale		
	205009-2-11	1	griffa principale	main feed dog	griffe principale		
	205059-0-10	1	griffa principale	main feed dog	griffe principale		
12	203783-0-10	1	coltello superiore	upper knife	couteau supérieur		

Fig. N. Abb. N.	Part. N. Bestell N. Pieze N. Pieza N.	Qt. Anzahi	DESCRIZIONE	DESCRIPTION	DESCRIPTION	BENENNUNG	DESCRIPCION
	<u>Tav. 4</u>						
1	207552-4-00	1	pressafilo completo	thread presser assembly	presse-fil complet		
5	203635-0-10	3	pastiglia	plug	bouchon		
16	205052-0-12	1	passafilo per ago	thread guide	passe-fil		
	<u>Tav. 5</u>						
▲	207476-4-00	1	albero princ. con cuscinetti	main shaft	arbre principal		
8	206701-2-01	1	albero principale	main shaft	arbre principal		
	<u>Tav. 10</u>						
★	207500-4-00	1	cinematismo comando aghi	needles control assembly	cinématisme comm. aiguilles		
▲	207516-4-00	1	morsetto porta aghi compl.	needles clamp assembly	porte-aiguilles compl.		
4	206515-0-01	1	leva	lever	levier		
28	207526-2-00	1	morsetto porta aghi	needles clamp	porte-aiguilles		
30	765200-6-11	1	ago sist. Rim 27 fin. 110	needle syst. Rim 27 size 110	aiguille syst. Rim 27 jauge 110		
41	765500-6-11	1	ago sist. Rim 29 fin. 110 punta sei	needle syst. Rim 29 size 110	aiguille syst. Rim 29 jauge 110		
	<u>Tav. 11</u>						
16	205042-0-11	1	molla premi piedino	spring	ressort		
	<u>Tav. 12</u>						
17	205024-0-10	1	spingi asola	front needle guard	pare-boucle		

**VARIANTE PER**

**VARIATION FOR**

**VARIANTE POUR**

129-00-2CD-12

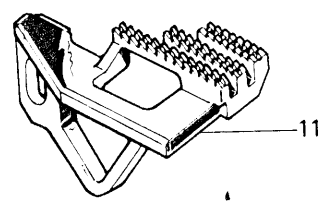
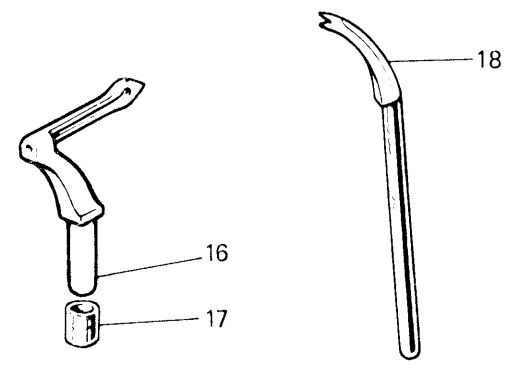
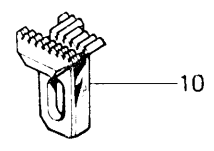
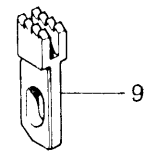
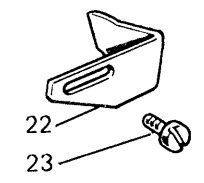
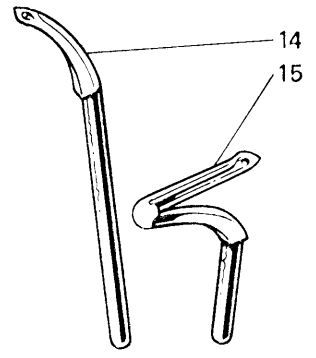
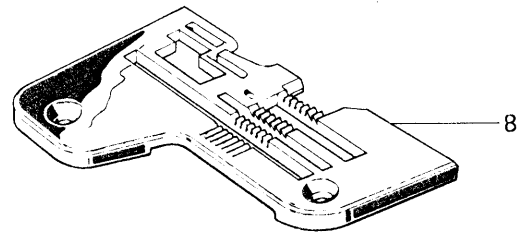
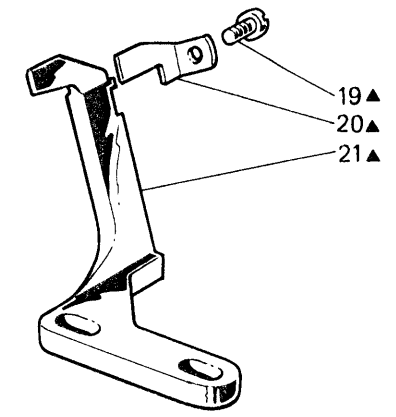
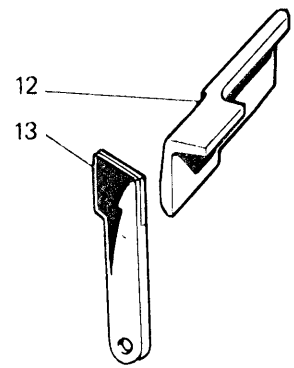
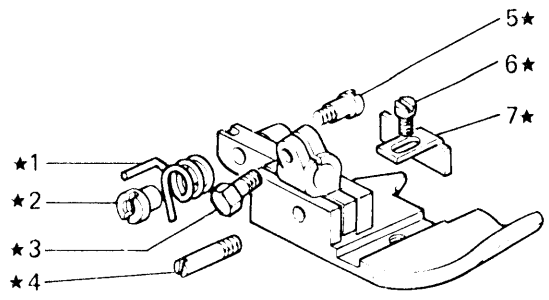

Fig. N. Abb. N.	Part. N. Bestell N. Piece N. Pieza N.	Qt. Anzahl	DESCRIZIONE	DESCRIPTION	DESCRIPTION	BENENNUNG	DESCRIPCION
★	206002-3-02	1	pedino completo	presserfoot assembly	pied-presseur complet		
▲	204862-4-10	1	gruppo spingi asola e salva ago	rear and front needle guard ass.	groupe pare-boucle et protège-aiguille		
1	204894-0-11	1	molla	spring	ressort		
2	204895-0-10	1	bussola filettata	bush	bague		
3	204947-0-10	1	vite	screw	vis		
4	204869-0-11	1	spina filettata	pin	goupille		
5	204889-0-10	1	vite	screw	vis		
6	741413-2-00	1	vite	screw	vis		
7	204878-0-11	1	piastrina	plate	plaque		
8	204864-0-10	1	placca ago larg. costa 5 mm	needle plate width bight 5 mm	plaque à aiguille larg. surjet 5 mm		
9	202609-0-10	1	griffino	chaining feed dog	petite griffe		
10	204943-0-11	1	griffa sussidiaria	subsidiary feed dog	griffe subsidiaire		
11	204941-0-10	1	griffa principale	main feed dog	griffe principale		
12	203759-0-10	2	coltello superiore	upper knife	couteau supérieur		
13	204693-0-11	2	coltello inferiore	lower knife	couteau inférieur		
14	204033-0-10	1	crochet superiore	upper looper	crochet supérieur		
15	202413-0-11	1	crochet inferiore	lower looper	crochet inférieur		
16	204676-0-11	1	crochet punto sicurezza	looper safety stitch	crochet point de sûreté		
17	204912-0-10	1	distanziale	spacer	entretoise		
18	202092-0-10	1	crochet superiore cieco	upper blind looper	crochet supérieur aveugle		
19	741431-0-00	1	vite	screw	vis		
20	204863-0-10	1	salva ago	rear needle guard	protège-aiguille		
21	204861-0-10	1	spingi asola	front needle guard	pare-boucle		
22	204905-0-10	1	squadretta	bracket	équerre		
23	721443-2-00	1	vite	screw	vis		
			SOLO A RICHIESTA	ONLY ON REQUEST	SEULEMENT SUR DEMANDE		
8	204948-0-10	1	placca ago larg. costa 4 mm	needle plate width bight 4 mm	plaque à aiguille larg. surjet 4 mm		
10	204850-0-10	1	griffa sussidiaria	subsidiary feed dog	griffe subsidiaire		
	204851-0-11	1	griffa sussidiaria	subsidiary feed dog	griffe subsidiaire		
	204942-0-10	1	griffa sussidiaria	subsidiary feed dog	griffe subsidiaire		
11	204846-0-10	1	griffa principale	main feed dog	griffe principale		
	204940-0-10	1	griffa principale	main feed dog	griffe principale		
	204997-0-00	1	griffa principale	main feed dog	griffe principale		
12	203783-0-10	1	coltello superiore	upper knife	couteau supérieur		
▲	<u>Tav. 5</u> 207476-4-00	1	albero princ. con cuscinetti	main shaft	arbre principal		
8	206701-2-01	1	albero principale	main shaft	arbre principal		
30	<u>Tav. 10</u> 765200-6-10	1	ago Rim 27 fin. 100	needle Rim 27 size 100	aiguille Rim 27 jauge 100		
41	765500-6-10	1	ago Rim 29 fin. 100 punta sei	needle Rim 29 size 100	aiguille Rim 29 jauge 100		

**VARIANTE PER**

**VARIATION FOR**

**VARIANTE POUR**

129-00-2MU-01

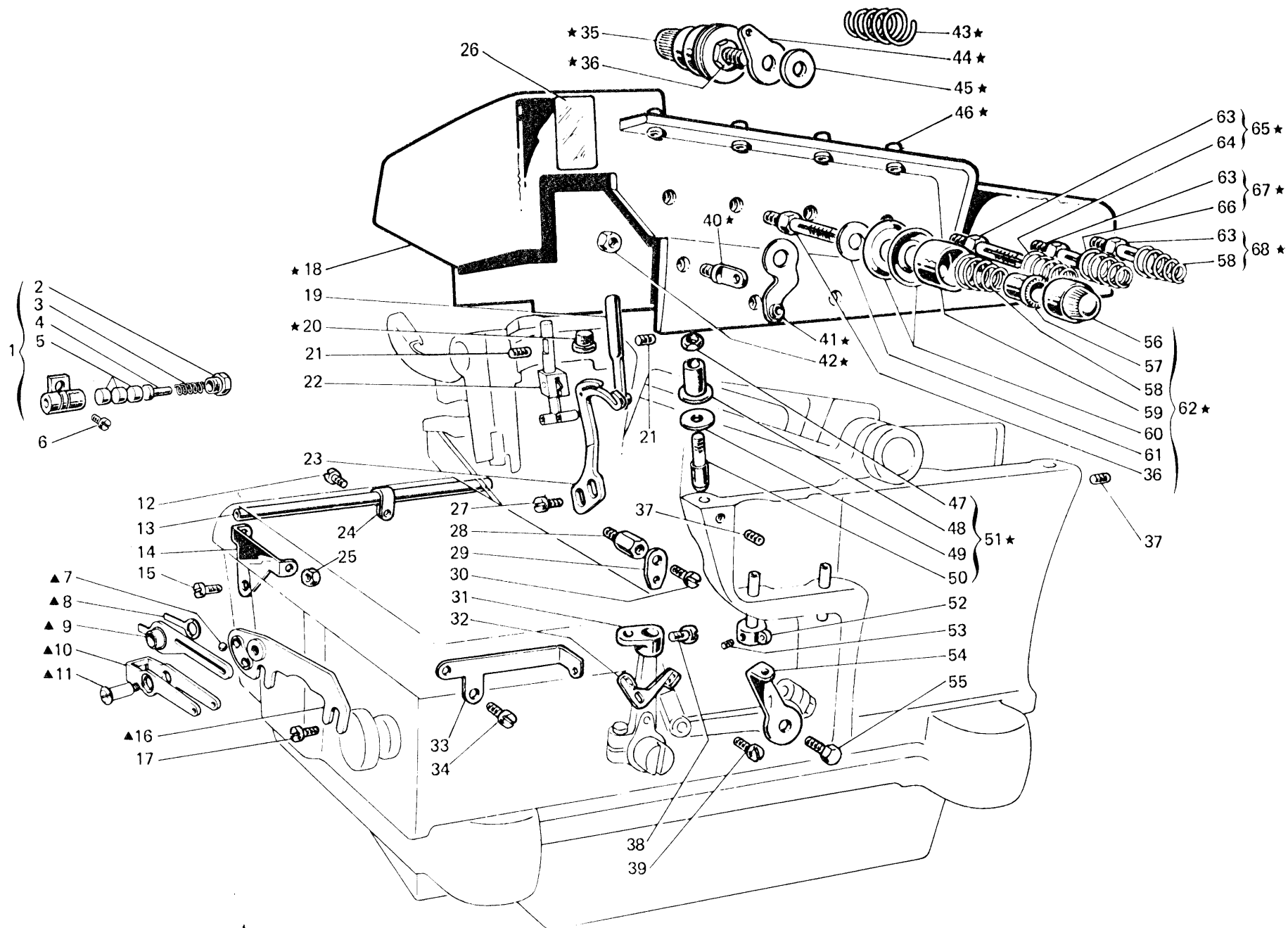

Fig. N. Abb. N.	Part. N. Bestell N. Piece N. Pieza N.	Qt. Anzahl	DESCRIZIONE	DESCRIPTION	DESCRIPTION	BENENNUNG	DESCRIPCION
▲	206091-4-01	1	gruppo passafili per camma	thread guide assembly	groupe passe-fils		
★	207773-4-00	1	coperchio superiore compl.	upper cover assembly	couvercle supérieur compl.		
1	207552-4-00	1	pressafilo completo	thread presser assembly	presse-fil complet		
2	202260-0-10	1	tappo filettato	plug	bouchon		
3	202257-0-10	1	molla	spring	ressort		
4	202258-0-10	1	pernetto	pin	pivot		
5	203635-0-10	3	pastiglia	plug	bouchon		
6	207562-0-00	1	vite	screw	vis		
7	707602-0-00	1	sfera	ball	sphère		
8	207224-0-00	1	molla	spring	ressort		
9	207221-2-00	1	passafilo	thread guide	passe-fil		
10	206090-0-10	1	passafilo laterale	side thread guide	passe-fil latéral		
11	207225-0-10	1	vite	screw	vis		
12	741559-2-00	1	vite	screw	vis		
13	204704-0-10	1	tubetto	pipe	tube		
14	204747-0-10	1	passafilo	thread guide	passe-fil		
15	724422-2-00	1	vite	screw	vis		
16	207219-0-10	1	supporto	support	support		
17	721424-2-00	2	vite	screw	vis		
18	207765-3-00	1	coperchio con passafili	cover with thread guide	couvercle avec passe-fils		
19	206714-2-00	1	passafilo	thread guide	passe-fil		
20	206746-0-10	2	tampone	pad	tampon		
21	729011-2-00	2	vite	screw	vis		
22	206093-3-00	1	passafilo per ago	needle thread guide	passe-fil de l'aiguille		
23	206987-0-01	1	tendifilo per ago	needle thread tension	tendeur du fil aiguille		
24	204756-0-10	1	fascetta	clamp	bride		
25	733505-2-00	1	dado	nut	écrou		
26	788300-0-00	1	decalcomania sist. aghi	needles syst. decalcomania	décalcomanie syst. aiguille		
27	741539-0-00	2	vite	screw	vis		
28	206755-0-00	1	colonnina per passafilo	threaded tube	tube pour passe-fil		
29	206812-0-00	1	passafilo crochet	looper thread guide	passe-fil crochet		
30	744631-2-00	1	vite	screw	vis		
31	204750-0-10	1	squadretta	bracket	équerre		
32	204911-0-10	1	passafilo	thread guide	passe-fil		
33	206876-0-00	1	passafilo	thread guide	passe-fil		
34	741682-0-00	1	vite	screw	vis		
35	206340-4-00	1	tensione compl. con fig. 36-43	tension ass. with fig. 36-43	tension compl. avec fig. 36-43		
36	202225-0-11	2	perno per tensione fig. 35-62	pin for tension fig. 35-62	pivot pour tension fig. 35-62		
37	745803-2-00	3	vite	screw	vis		
38	741400-0-00	1	vite	screw	vis		
39	741657-0-00	1	vite	screw	vis		
40	206711-0-00	3	passafilo	thread guide	passe-fil		
41	206713-2-00	1	passafilo	thread guide	passe-fil		
42	733503-0-00	3	dado	nut	écrou		
43	203457-0-10	1	molla per tensione fig. 35	spring for tension fig. 35	ressort pour tension fig. 35		
44	203630-0-10	1	passafilo	thread guide	passe-fil		
45	705013-0-00	1	rondella	washer	rondelle		
46	202271-0-11	4	passafilo	thread guide	passe-fil		
47	207123-0-00	3	dado	nut	écrou		



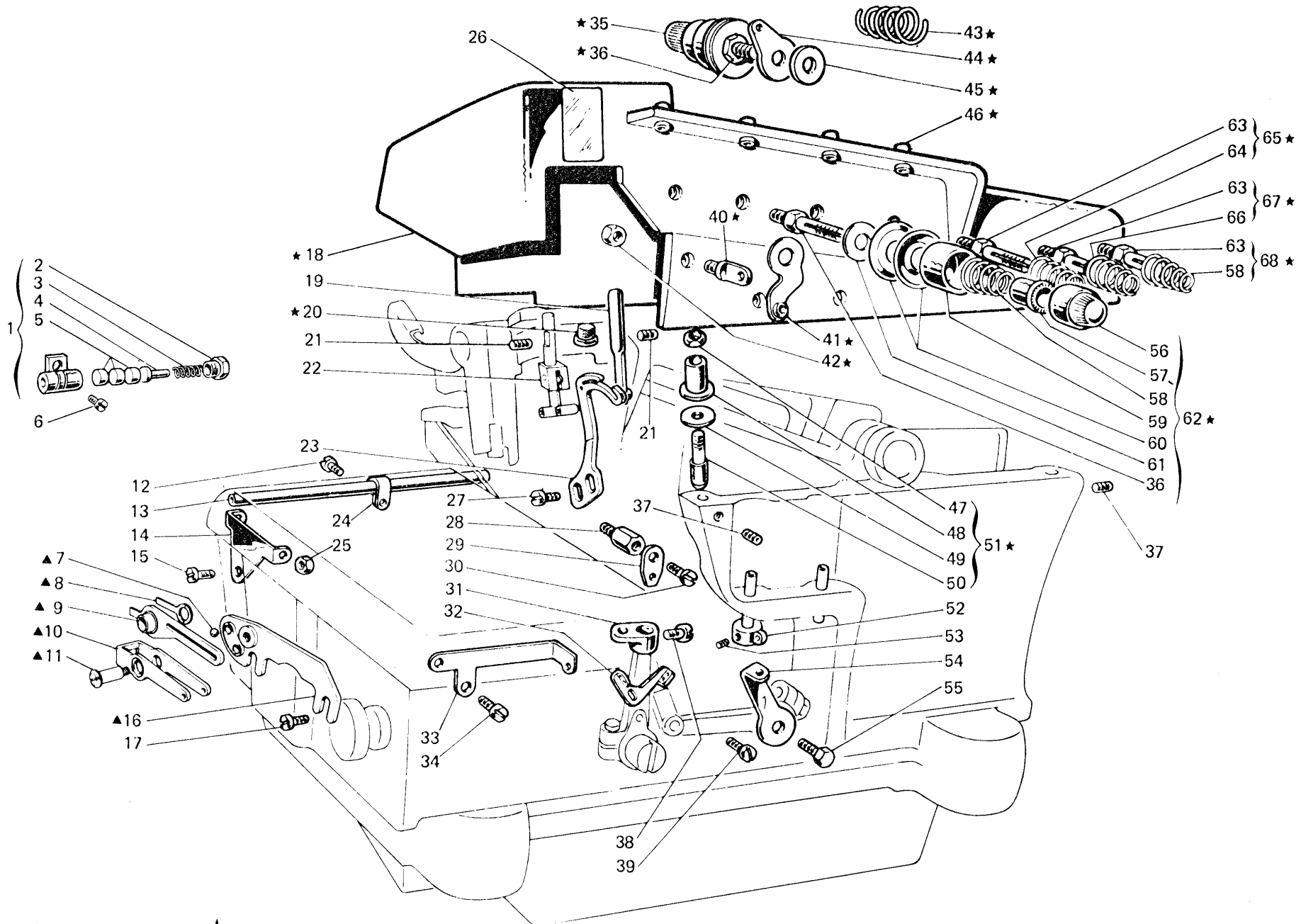

Fig. N. Abb. N.	Part. N. Bestell N. Piece N. Pieza N.	Qt. Anzahl	DESCRIZIONE	DESCRIPTION	DESCRIPTION	BENENNUNG	DESCRIPCION
48	207122-0-00	3	bussola in gomma	bush	bague		
49	704207-2-00	3	rondella	washer	rondelle		
50	207120-0-00	3	spina	pin	goupille		
51	207124-4-00	3	spina per coperchio compl.	pin for cover assembly	goupille pour couvercle compl.		
52	203135-2-10	1	passafile	thread guide	passe-fil		
53	745002-0-00	1	vite	screw	vis		
54	202683-0-10	1	tendifilo crochet	thread take-up	tendeur du fil crochet		
55	720431-2-00	1	vite	screw	vis		
56	202558-2-00	5	pomolo	knob	pommeau		
57	202229-0-10	5	bussola	bush	bague		
58	202227-0-10	2	molla	spring	ressort		
59	202556-0-00	5	scodellino	cup	cuvette		
60	300218-0-10	10	disco per tensione	disc for tension	disque pour tension		
61	206754-0-00	5	rondella	washer	rondelle		
62	206346-4-00	1	tensione completa	tension assembly	tension compl.		
63	206747-0-01	3	perno per tensione compl.	pin for tension ass.	pivot pour tension compl.		
64	202228-0-10	1	molla per tensione compl.	spring for tension ass.	ressort pour tension compl.		
65	206342-4-00	1	tensione completa	tension assembly	tension compl.		
66	202681-0-10	1	molla per tensione compl.	spring for tension ass.	ressort pour tension compl.		
67	206343-4-00	1	tensione completa	tension assembly	tension compl.		
68	206341-4-00	1	tensione completa	tension assembly	tension compl.		

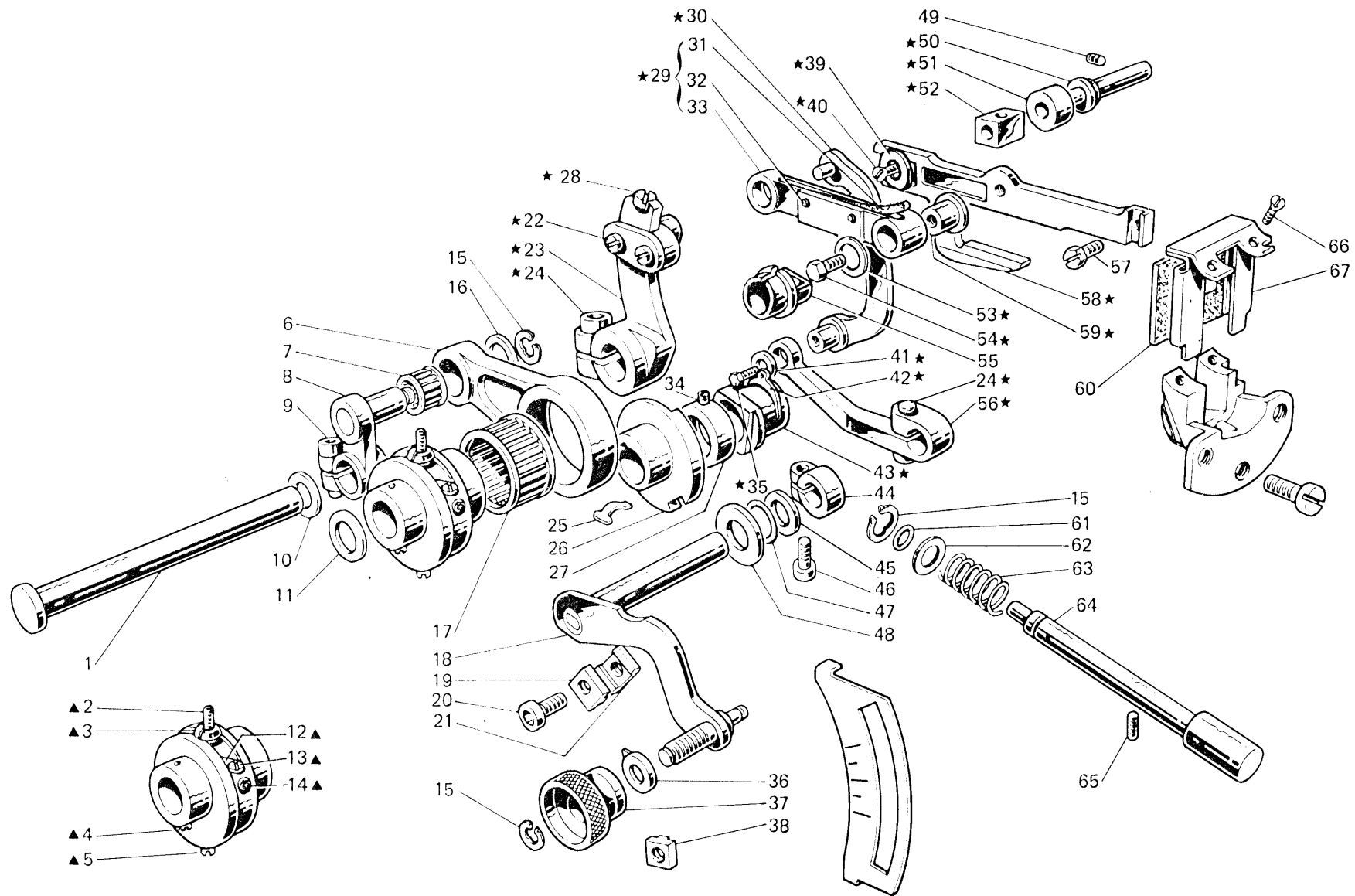

Fig. N. Abb. N.	Part. N. Bestell N. Pieze N. Pieza N.	Qt. Anzahl	DESCRIZIONE	DESCRIPTION	DESCRIPTION	BENENNUNG	DESCRIPCION
★	207090-4-00	1	gruppo comando griffa	feed dog control assembly	groupe commande griffe		
▲	206998-4-00	1	gruppo eccentr. regol. trasp.	eccentric group	groupe excentrique		
1	206593-0-00	1	contralbero trasporto	transport countershaft	axe transport		
2	729051-2-00	1	vite	screw	vis		
3	206603-0-10	1	fermo eccentrico	eccentric retainer	pièce blocage excentrique		
4	745125-2-00	1	vite	screw	vis		
5	727884-0-00	1	vite	screw	vis		
6	206599-0-01	1	biella comando trasporto	transport connecting rod control	bielle commande transport		
7	201358-0-10	1	gabbia a rullini	needles cage	cage à aiguilles		
8	206598-3-00	1	braccio a manovella con vite	con-rod with screw	bras à manivelle avec vis		
9	744334-2-00	1	vite	screw	vis		
10	704841-0-00	1	rondella	washer	rondelle		
11	206532-0-00	1	rondella	washer	rondelle		
12	202412-0-10	1	lardone	gib	lardon		
13	202473-0-11	2	vite	screw	vis		
14	730011-2-00	2	vite	screw	vis		
15	700207-0-00	3	anello elastico	spring ring	anneau ressort		
16	206546-0-00	1	rondella	washer	rondelle		
17	202385-0-10	1	gabbia a rullini	needles cage	cage à aiguilles		
18	206790-2-00	1	leva comando slitta	lever	levier		
19	206799-0-00	1	arresto regolabile esterno	external retainer	butée réglable externe		
20	722433-2-00	2	vite	screw	vis		
21	206795-0-00	2	arresto regolabile interno	internal retainer	butée réglable interne		
22	741546-2-00	2	vite	screw	vis		
23	206592-3-00	1	manovella trasporto con viti	transport crank with screws	manivelle transport avec vis		
24	744332-2-00	2	vite	screw	vis		
25	206872-0-00	1	molla	spring	ressort		
26	206605-0-01	1	eccentrico	eccentric	excentrique		
27	206606-2-00	1	anello di rasamento	shim	bague		
28	741413-0-00	1	vite	screw	vis		
29	206615-4-00	1	biellino completo	con-rod assembly	petite bielle complète		
30	202047-2-10	1	leva	lever	levier		
31	778417-0-00	1	stoppino	wick	mèche		
32	200490-0-00	2	spillo	pin	goupille		
33	206587-0-01	1	biellino	con-rod	petite pielle		
34	745812-2-00	2	vite	screw	vis		
35	740220-2-00	1	vite	screw	vis		
36	206796-0-00	1	indice rapporto differenziale	differential index	indice différentiel		
37	206798-0-00	1	bottono rapp. differenz.	differential button	bouton différentiel		
38	206794-0-00	1	arresto regolabile esterno	external retainer	butée réglable externe		
39	202475-0-10	1	rondella	washer	rondelle		
40	724032-0-00	1	vite	screw	vis		
41	705201-0-00	1	rondella	washer	rondelle		
42	201610-0-01	1	anello elastico	spring ring	anneau ressort		
43	206616-0-00	1	blocchetto	block	bloc		
44	100620-2-10	1	morsetto con vite	clamp with screw	collier de serrage avec vis		
45	704829-0-00	1	rondella	washer	rondelle		
46	741745-2-00	1	vite	screw	vis		
47	701007-0-00	1	anello di tenuta	circlip	circlip		

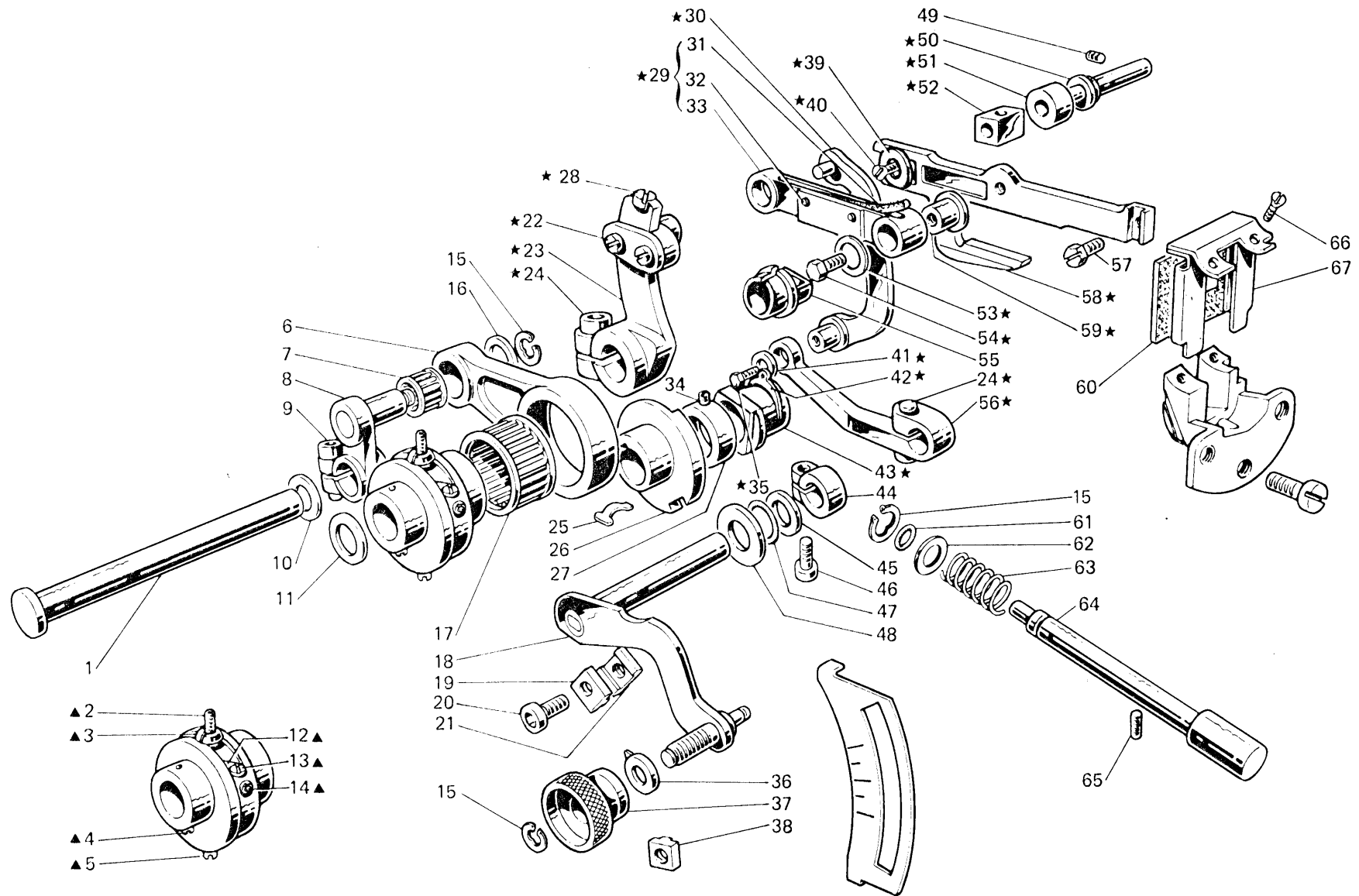

Fig. N. Abb. N.	Part. N. Bestell N. Piece N. Pieza N.	Qt. Anzahl	DESCRIZIONE	DESCRIPTION	DESCRIPTION	BENENNUNG	DESCRIPCION
48	705230-0-00	1	rondella	washer	rondelle		
49	202478-0-10	1	vite	screw	vis		
50	206613-0-00	1	perno eccentrico	eccentric pin	pivot excentrique		
51	202973-0-10	1	distanziale	spacer	entretoise		
52	202922-0-10	1	blocchetto	block	bloc		
53	705008-0-00	1	rondella	washer	rondelle		
54	206588-0-00	1	vite	screw	vis		
55	206619-0-00	1	vaschetta olio	oil sump	cuvette huile		
56	206614-2-01	1	braccio regol. differenz.	differential arm	bras différentiel		
57	202489-0-10	1	vite	screw	vis		
58	206585-0-01	1	gruppo slitta porta griffe	feed dog slide group	groupe support porte-griffe		
59	206586-0-01	1	bussola per biellino	bush	bague		
60	206805-0-00	1	raschia olio	oil scraper	râcheur d'huile		
61	701004-0-00	1	anello	ring	anneau		
62	704314-2-00	1	rondella	washer	rondelle		
63	202408-0-10	1	molla	spring	ressort		
64	206618-0-10	1	pulsante regol. punto	push-button	poussoir réglable point		
65	729032-2-00	1	vite	screw	vis		
66	744621-0-00	2	vite	screw	vis		
67	206607-2-00	1	telaio raschia olio	oil scraper frame	râcheur d'huile		

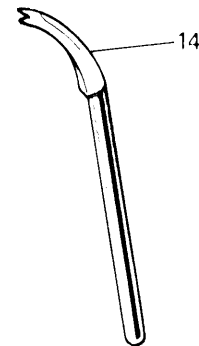
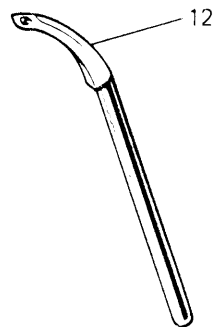
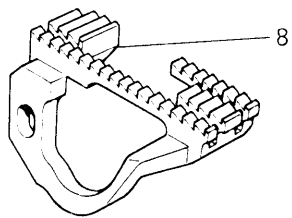
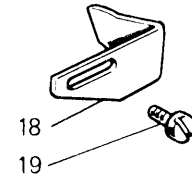
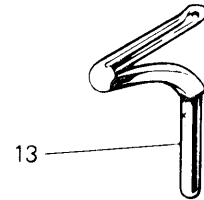
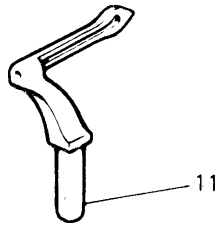
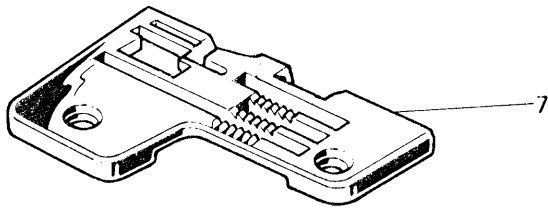
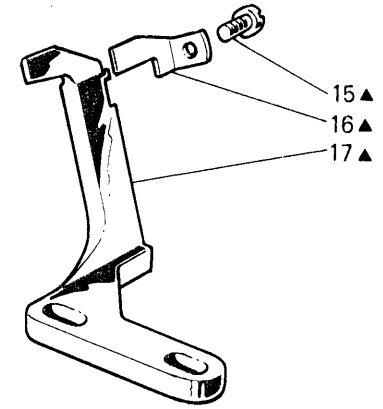
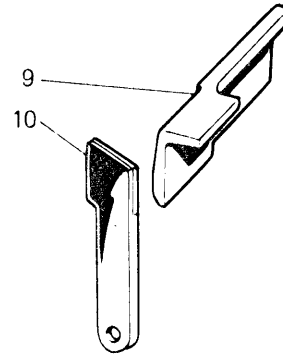
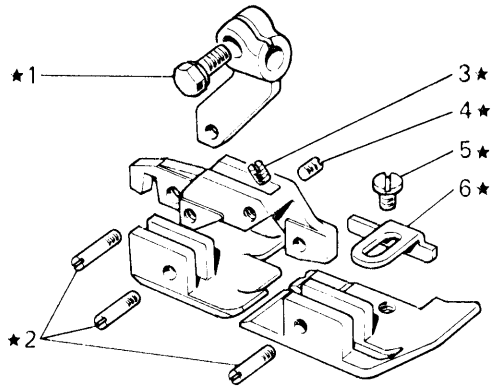

Fig. N. Abb. N.	Part. N. Bestell N. Piece N. Pieza N.	Qt. Anzahl	DESCRIZIONE	DESCRIPTION	DESCRIPTION	BENENNUNG	DESCRIPCION
▲	206051-4-10	1	gruppo spingi asola e salva ago	front and rear needle guard ass.	groupe pare-boucle et protège-aiguille		
★	207133-3-02	1	pedino completo	presserfoot assembly	pied-presseur complet		
1	204947-0-10	1	vite	screw	vis		
2	204869-0-11	3	vite	screw	vis		
3	727021-0-00	1	vite	screw	vis		
4	745001-0-00	1	vite	screw	vis		
5	741413-2-00	1	vite	screw	vis		
6	206982-0-01	1	piastrina	plate	plaque		
7	207234-0-11	1	placca ago larg. costa 5 mm	needle plate width bight 5 mm	plaque à aiguille larg. surjet 5 mm		
8	207233-0-10	1	griffa	feed dog	griffe		
9	203759-0-10	2	coltello superiore	upper knife	couteau supérieur		
10	206062-0-01	2	coltello inferiore	lower knife	couteau inférieur		
11	206048-0-13	1	crochet punto sicurezza	looper	crochet		
12	207208-0-00	1	crochet superiore	upper looper	crochet supérieur		
13	202413-0-11	1	crochet inferiore	lower looper	crochet inférieur		
14	202092-0-10	1	crochet superiore cieco	upper blind looper	crochet supérieur aveugle		
15	741431-0-00	1	vite	screw	vis		
16	204863-0-10	1	salva ago	rear needle guard	protège-aiguille		
17	206050-0-10	1	spingi asola	front needle guard	pare-boucle		
18	204905-0-10	1	squadretta	bracket	équerre		
19	721443-2-00	1	vite	screw	vis		
			SOLO A RICHIESTA	ONLY ON REQUEST	SEULEMENT SUR DEMANDE		
9	203783-0-10	1	coltello superiore	upper knife	couteau supérieur		



Fig. N. Abb. N.	Part. N. Bestell N. Piece N. Pieza N.	Qt. Anzahl	DESCRIZIONE	DESCRIPTION	DESCRIPTION	BENENNUNG	DESCRIPCION
	<u>Tav. 1</u>						
★ 21	207469-3-00 206847-0-00	1 1	base con bussole guida slitta	base and bush slide guide	base avec bagues guide glissière		
	<u>Tav. 3</u>						
▲ 1	207217-4-01 207231-2-01	1 1	carter laterale completo carter laterale	side cover assembly side cover	carter latéral complet carter latéral		
	<u>Tav. 5</u>						
▲ 8 11	207476-4-00 206701-2-01 206994-2-00	1 1 1	albero princ. con cuscinetti albero principale camma tendifilo con viti	main shaft main shaft thread guide with screws	arbre princ. avec roulements arbre princ. came tendeur du fil avec vis		
	<u>Tav. 7</u>						
★ ▲ 8 11 12 16 25	206398-4-00 206420-4-00 704847-0-00 206450-4-00 206648-2-01 206414-3-00 206653-2-00	1 1 2 1 1 1 1	gruppo manicotti com. crochet gruppo comando crochet super. rondella gruppo manicotto con biella manicotto guida oscillante braccio	control looper assembly upper looper control ass. washer coupling ass. with con-rod coupling oscillating guide arm	groupe manchon comm. crochet groupe comm. crochet sup. rondelle groupe manchon avec bielle manchon guide oscillant bras		
			PEZZI ANNULLATI	CANCELLED PARTS	PIECES ANNULEES		
13	704845-0-00	1	rondella	washer	rondelle		
	<u>Tav. 8</u>						
★ 18 26	207213-4-00 206041-3-00 207212-0-00	1 1 1	porta crochet inf. compl. porta crochet con vite spina eccentrica	lower looper holder ass. looper holder with screw eccentric pin	porte crochet inférieur compl. porte crochet avec vis goupille excentrique		
	<u>Tav. 10</u>						
★ ▲ 4 28 30 41 42	207500-4-00 207516-4-00 206515-0-01 207526-2-00 765200-6-12 765500-6-12 206542-2-00	1 1 1 1 1 1 1	cinematismo com. aghi morsetto porta aghi compl. leva morsetto porta aghi ago Rim 27 fin. 120 ago Rim 29 fin. 120 punta sei manovella alb. sup. con vite	needles control assembly needles clamp assembly lever needles clamp needle Rim 27 size 120 needle Rim 29 size 120 con-rod with screw	cinématisme comm. aiguilles porte-aiguilles complet levier porte-aiguilles aiguille Rim 27 jauge 120 aiguille Rim 29 jauge 120 bras arbre sup. avec vis		
	<u>Tav. 11</u>						
■ 15 16 40	206809-4-00 206808-0-00 206985-0-00 990694-0-00	1 1 1 1	leva premistoffa con perno leva molla premi piedino salvadita	presser lever lever spring protection	levier du pied-presseur avec pivot levier ressort protection		

Fig. N. Abb. N.	Part. N. Bestell N. Piece N. Pieza N.	Qt. Anzahl	DESCRIZIONE	DESCRIPTION	DESCRIPTION	BENENNUNG	DESCRIPCION
	<u>Tav. 12</u>						
16	741526-0-00	1	vite	screw	vis		
17	206075-0-02	1	salva ago	rear needle guard	protège-aiguille		
	<u>Tav. 4</u>		PEZZI ANNULLATI ANNULLATA	CANCELLED PARTS CANCELLED	PIECES ANNULEES ANNULEE		
	<u>Tav. 6</u>		ANNULLATA	CANCELLED	ANNULEE		

**VARIANTE PER**

**VARIATION FOR**

**VARIANTE POUR**

129-00-2CD-22

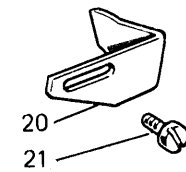
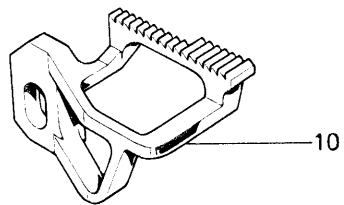
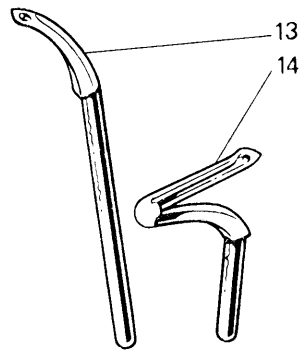
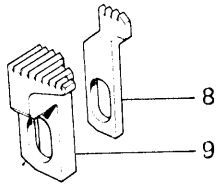
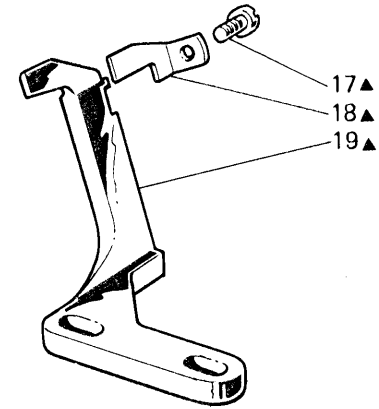
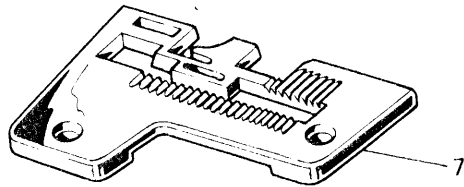
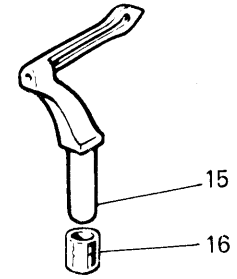
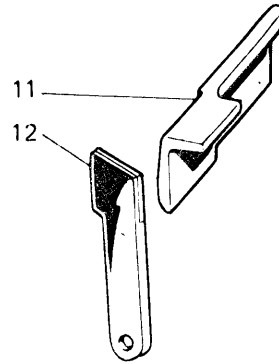
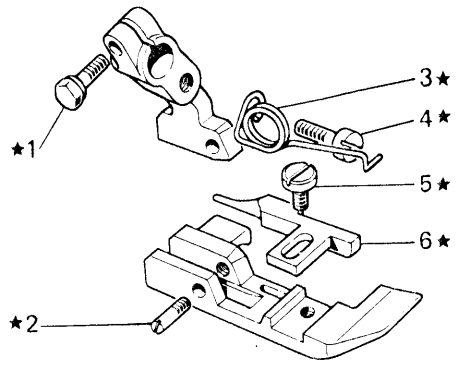

Fig. N. Abb. N.	Part. N. Piecce N. Bestell N. Pieza N.	Qt. Anzahl	DESCRIZIONE	DESCRIPTION	DESCRIPTION	BENENNUNG	DESCRIPCION
★	205824-3-00	1	piedino completo	presserfoot assembly	pied-presseur complet		
▲	204862-4-10	1	gruppo spingi asola e salva ago	front and rear needle guard ass.	groupe protège-aiguille et pare-boucle		
1	204947-0-10	1	vite	screw	vis		
2	204869-0-11	1	spina	pin	goupille		
3	205822-0-00	1	molla	spring	ressort		
4	741654-0-00	1	vite	screw	vis		
5	721411-2-00	1	vite	screw	vis		
6	205620-0-00	1	linguetta	tongue	languette		
7	205816-0-00	1	placca ago larg. costa 3,7 mm.	needle plate width bight 3,7 mm	plaque à aiguille largeur surjet 3,7 mm		
8	205830-0-00	1	griffino	feed dog	petite griffe		
9	205818-0-00	1	griffa sussidiaria	subsidiary feed dog	griffe subsidiaire		
10	205817-0-00	1	griffa principale	main feed dog	griffe principale		
11	203783-0-10	2	coltello superiore	upper knife	couteau supérieur		
12	204693-0-11	2	coltello inferiore	lower knife	couteau inférieur		
13	204033-0-10	1	crochet superiore	upper looper	crochet supérieur		
14	202413-0-11	1	crochet inferiore	lower looper	crochet inférieur		
15	204676-0-11	1	crochet punto sicurezza	safety stitch looper	crochet point de sûreté		
16	204912-0-10	1	distanziale	spacer	entretoise		
17	741431-0-00	1	vite	screw	vis		
18	204863-0-10	1	salva ago	rear needle guard	protège-aiguille		
19	204861-0-10	1	spingi asola	front needle guard	pare-boucle		
20	204905-0-1	1	squadretta	bracket	équerre		
21	721443-2-00	1	vite	screw	vis		
			SOLO A RICHIESTA	ONLY ON REQUEST	SEULEMENT SUR DEMANDE		
11	203759-0-10	1	coltello superiore	upper knife	couteau supérieur		
	<u>Tav. 11</u>						
■	205831-4-00	1	leva premistoffa con perno	presser lever	levier du pied-presseur avec pivot		
15	205823-0-00	1	leva	lever	levier		
			PEZZI ANNULLATI	CANCELLED PARTS	PIECES ANNULEES		
16	204891-0-11	1	molla premi piedino	spring	ressort		
17	203187-0-10	1	vite	screw	vis		