

# Rimoldi

CATALOGO PEZZI DI RICAMBIO  
SPARE PARTS CATALOGUE  
CATALOGUE RECHANGES  
ERSATZTEILELISTE

261-34-2DR-25  
261-34-2DR-26  
261-34-2DR-28  
261-34-2DR-43  
261-34-3DR-18  
261-34-3DR-24  
  
261-34-2DR-15  
261-34-3DR-55

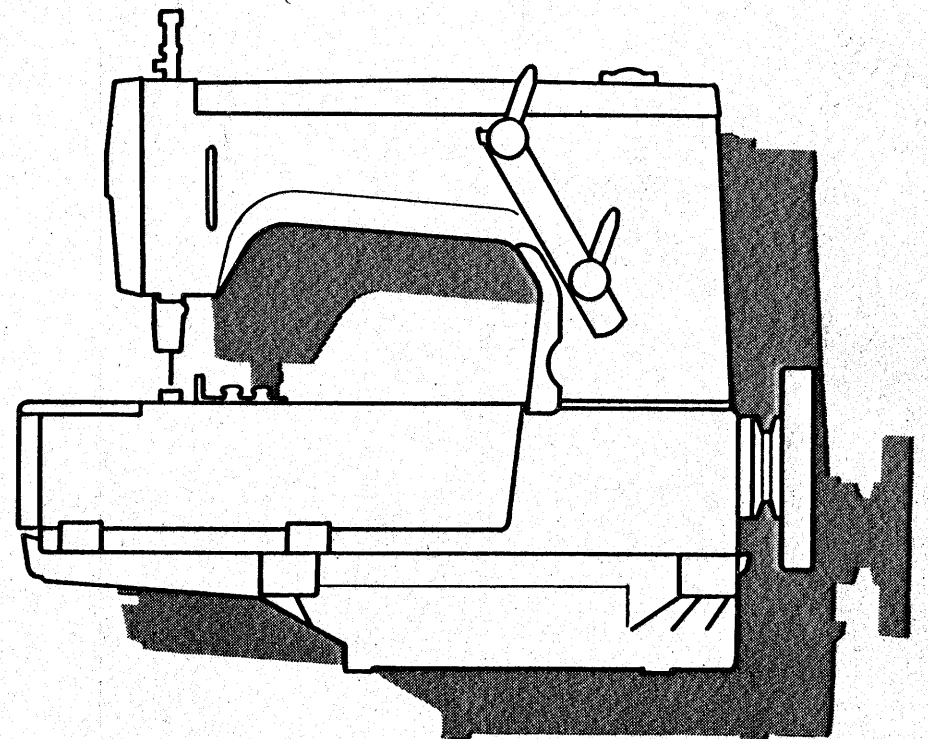

**n. 155**

652691030

UFFICIO CATALOGHI 1/76

Il presente Catalogo Pezzi di Ricambio è costituito da due parti: la prima, definita come "Catalogo base", comprende i particolari montati sulla testa più significativa (la prima dell'elenco in copertina); la seconda comprende tutti i particolari delle altre teste basi o derivate, che differiscono da quella del Catalogo base.

Le Teste basi sono elencate in copertina con un carattere più grande rispetto a quello delle derivate.

Nella consultazione del Catalogo tenere presente che:

1. Tutti i particolari non fornibili sciolti non vengono richiamati singolarmente, ma soltanto illustrati nel gruppo d'appartenenza.
2. I riferimenti delle figure dei particolari che compongono il gruppo sono di norma raggruppati in una parentesi. In alcuni casi però, dove non è possibile il raggruppamento, i numeri che nelle tavole illustrative richiamano i singoli pezzi sono affiancati dallo stesso segno particolare, con cui è indicato l'intero gruppo.
3. Sulle tavole relative alle altre teste sono elencati tutti i particolari diversi o non montati sulla testa del Catalogo Base. Dette tavole portano in alto a destra il simbolo della testa cui si riferiscono (con indicato fra parentesi - nel caso di derivata - il simbolo della testa da cui deriva).  
I disegni di questo gruppo di tavole illustrano soltanto i pezzi nuovi o sostanzialmente diversi rispetto a quelli montati sulla testa più significativa del Catalogo.  
I particolari richiamati come simbolo, ma non illustrati, conservano lo stesso numero di figura dei corrispondenti raffigurati sul Catalogo base.  
I particolari comuni a tutte le teste comprese nel Catalogo, vengono richiamati soltanto nel primo gruppo di tavole.  
I particolari definiti come "pezzi annullati" si intendono quelli non montati sulla testa a cui la tavola si riferisce. Nel caso di un gruppo annullato, viene indicato soltanto il simbolo del gruppo, ma devono intendersi annullati anche tutti i particolari componenti il gruppo stesso.  
Per ogni testa viene sempre riportata interamente la tavola relativa agli organi di cucitura.

Per facilitare la ricerca viene riportato l'indice numerico di tutti i particolari illustrati sul Catalogo base, con la relativa tavola in cui gli stessi sono richiamati.

#### AGHI

Gli aghi sono contraddistinti dal sistema e dalla finezza, la quale indica il diametro medio espresso in centesimi di millimetro.

Il sistema dell'ago e la finezza sono marcati oltre che sulla busta, anche sull'ago stesso.

Nelle ordinazioni precisare, oltre il simbolo, il sistema e la finezza degli aghi desiderati. In caso di dubbio, allegare, un ago campione o una bustina vuota.

#### AVVERTENZA

Nella richiesta di parti di ricambio citare sempre il relativo numero di matricola della macchina, il simbolo del particolare e la denominazione ufficiale usata sul catalogo.

This spare parts catalogue is made up of two parts: in the first one, called "basic catalogue", all the details of most representative head are listed (the first head listed on the cover); the second one includes the details of the other main heads or derived ones, which are different from that of the basic catalogue.

The main heads are listed on the cover in bigger lettering to distinguish them from the derived heads.

When you consult the catalogue will you please note that:

1. all parts which cannot be supplied by themselves are not indicated alone, but shown together with the group to which they belong;

2. the references of the pictures of the parts making up the group are usually put in brackets.

In some cases, however, when their grouping is not possible, the numbers of the various parts in the tables are marked with the same particular sign with which the whole group is indicated.

3. In the tables of the other heads there are listed all the parts not fitted on the head in the basic catalogue.

These tables are marked at the top right-hand corner with the symbol of the head which the table refers to.

The drawings in this group of tables show only the parts which are new or basically different from those fitted on the most representative head in the catalogue.

The parts which are represented only by the symbol but not illustrated keep the same figure number as the corresponding parts shown in the basic catalogue.

The parts which are common to all the heads in the catalogue are listed only in the first group of tables.

Parts marked "annulled part" are those not fitted on the head which the table refers to.

When an assembly has been annulled only the assembly symbol is specified, but all the parts forming the assembly must also be considered annulled.

For each head the table for sewing parts is always repeated completely

To make it easier to locate the parts, the reference numbers of all of those shown in the basic catalogue are listed together with the number of the table in which they are to be found.

#### NEEDLES

The needles are marked with system and size; the size indicates the average diameter in hundredths of a millimeter.

The system and size of the needle are shown on the packet as well as on the needle itself.

When ordering please state symbol, system and size. If you have doubts, enclose a sample needle or an empty packet with your order.

#### ATTENTION

When ordering spare parts always state the serial number of the machine, the symbol of the part in question and the description given in the catalogue.

Ce catalogue "pièces détachées" est formé de deux parties: la première appelée "catalogue base" comprend toutes les pièces montées sur la tête la plus significative (celle en tête de la liste de couverture), la seconde comprend toutes les pièces montées sur les autres têtes de base ou dérivées qui sont différentes de celle du "catalogue base".

Les têtes de base sont énumérées sur la couverture, en caractères plus grands que les têtes dérivées.

Lorsque l'on consulte le catalogue, se souvenir que:

1. Toutes les pièces qui ne sont pas fournies séparément mais qui font partie d'un groupe, ne sont pas indiquées séparément.

2. Les symboles des pièces qui forment un groupe sont regroupés entre parenthèses. Cependant, lorsque ceci n'a pas été possible, les symboles, qui dans les tables d'illustration correspondent aux pièces, sont suivis du même signe particulier qui indique le groupe tout entier.

3. Dans les tables relatives aux autres têtes, nous avons indiqué toutes les pièces différentes de celles de tête du "catalogue base" ou qui ne sont pas montées sur ces dernières.

Ces tables portent, en haut à droite, le symbole des têtes auxquelles elles se réfèrent (pour les dérivées, le symbole de la tête de laquelle elles dérivent est indiqué entre parenthèses).

Les dessins de ce groupe de tables représentent seulement les nouvelles pièces ou celles qui sont différentes des pièces montées sur la tête la plus significative du catalogue.

Les pièces indiquées par un symbole, mais qui ne sont pas illustrées, gardent le même numéro de dessin que celles correspondantes, illustrées sur le catalogue base.

Les pièces communes à toutes les têtes du catalogue, sont indiquées seulement dans le premier groupe de tables.

Les pièces définies comme "pièces annulées" sont celles qui ne sont pas montées sur la tête à laquelle se réfère la table. Dans le cas de l'annulation d'un groupe, nous indiquons seulement le symbole du groupe, mais toutes les pièces qui forment ce groupe sont annulées.

Pour chaque tête est toujours indiquée la table se référant aux organes de couture.

Pour faciliter la recherche, le catalogue renferme l'index numérique de toutes les pièces illustrées avec indication de la table dans laquelle elles sont indiquées.

#### AIGUILLES

Les aiguilles se différencient par le système et la grosseur, laquelle indique le diamètre moyen exprimé en centièmes de millimètre.

Le système de l'aiguille et sa grosseur, sont indiqués non seulement sur le sachet mais également sur l'aiguille.

Dans la commande, préciser, en plus du symbole, le système et la grosseur des aiguilles désirées. En cas de doute, joindre une aiguille comme modèle ou un sachet vide.

#### ATTENTION

Dans la commande de pièces détachées, indiquer toujours le numéro de la machine, le symbole de la pièce et la dénomination officielle mentionnée sur le catalogue.

TAV. N. TAB. N.	DESCRIZIONE	DESCRIPTION	DESCRIPTION
1	BASE E BRACCIO CON BUSSOLE	BASE AND ARM WITH BUSHES	BASE ET BRAS AVEC BAGUES
2	PASSAFILI E TENS. CROCHET INFER.	THREAD GUIDE AND TENSION	PASSE-FILS ET TENSION
3	COPERCHI E PIANO DI LAVORO	COVERS AND WORKING PLATE	CARTERS ET PLAN DE TRAVAIL
4	GRUPPO PORTA GRIFFA	FEED DOG HOLDER ASSEMBLY	GROUPE PORTE-GRIFFE
5	GRUPPO BIELLA	CON-ROD ASSEMBLY	GROUPE BIELLE
6	ECCENTRICO REGOLABILE	ECCENTRIC	EXCENTRIQUE
7	GRUPPO ALBERO INFERIORE	LOWER SHAFT ASSEMBLY	GROUPE ARBRE INFERIEUR
8	GRUPPO CROCHET INFERIORE	LOWER LOOPER ASSEMBLY	GROUPE CROCHET INFERIEUR
9	GRUPPO COMANDO CROCHET INF.	LOWER LOOPER CONTROL ASS.	GROUPE COMMANDE CROCHET INF.
10	ALBERO SUPER. E BARRA AGO	UPPER SHAFT AND NEEDLE BAR	ARBRE SUP. ET BARRE AIGUILLE
11	GRUPPO PREMISTOFFA	PRESSER ASSEMBLY	GROUPE PRESSEUR
12	GRUPPO FRIZIONE	CLUTCH ASSEMBLY	FRICTION COMPLETE
13	GRUPPO PORTA COLTELLI	KNIVES HOLDER ASSEMBLY	GROUPE PORTE-COUTEAUX
14	GRUPPO TENSIONI ANTERIORI	FRONT TENSIONS ASSEMBLY	GROUPE TENSIONS AVANT
15	BACINELLA OLIO	OIL SUMP	RESERVOIR
16	LUBRIFICAZIONE E POMPA OLIO	LUBRICATION AND OIL PUMP	LUBRIFICATION ET POMPE A HUILE
17	ORGANI DI CUCITURA	SEWING PARTS	ORGANES COUTURE
18	ACCESSORI IN DOTAZIONE	AUXILIARY EQUIPMENT	ACCESSOIRES IN DOTATION
19	PIAZZAMENTO NORMALE	NORMAL SETTING	INSTALLATION NORMALE
20	PIAZZAMENTO INCASSATO	SUBMERGED SETTING	INSTALLATION ENCASTREE
21	PORTA BOBINE	BOBBIN CARRIER	PORTE BOBINES
22	TESTA 261-34-2DR-26	261-34-2DR-26 HEAD	TETE 261-34-2DR-26
23	TESTA 261-34-2DR-28	261-34-2DR-28 HEAD	TETE 261-34-2DR-28
24	TESTA 261-34-2DR-43	261-34-2DR-43 HEAD	TETE 261-34-2DR-43
25	TESTA 261-34-3DR-18	261-34-3DR-18 HEAD	TETE 261-34-3DR-18
26	TESTA 261-34-3DR-24	261-34-3DR-24 HEAD	TETE 261-34-3DR-24
27	TESTA 261-34-2DR-15	261-34-2DR-15 HEAD	TETE 261-34-2DR-15
28	TESTA 261-34-3DR-55	261-34-3DR-55 HEAD	TETE 261-34-3DR-55

SIMBOLO SYMBOL SYMBOLE	CARATTERISTICHE TESTE	MACHINE HEAD FEATURES	CARACTERISTIQUES TETES
261-34-2DR-15	Per applicare elastici e pizzi elastici provenienti da rotolo dall'alto ed alimentati, per mantenere la costanza di sviluppo, da rulli dosatori superiori, a mutandine da donna e simili in tessuti leggeri e medi. Dotata di coltelli rifilatori disinnestabili per rifilare il tessuto. Con differenziale. Velocità max. 5200 g/1' - N. punti per poll. 9 ÷ 18	For attaching elastics and elastic lace, coming from a roll placed above and fed from top metering rollers which permit uniform feeding, to ladies' panties and the like in light and medium fabrics. Fitted with disengageable trimming knives to trim fabric edge. With differential feed. Max speed 5200 r.p.m. - Stitch per inch. 9 ÷ 18	Pour appliquer des dentelles élastiques, provenant de rouleau placé en haut et alimentés par des rouleaux doseurs supérieurs sur des culottes pour dames et articles similaires en tissu légers et moyens. Elle est équipée de couteaux raseurs débrayables et de transport différentiel. Vitesse max 5200 t.p.m. - N. point par pouce 9 ÷ 18
261-34-2DR-25	Per applicare elastici e pizzi elastici provenienti da rotolo dall'alto ed alimentati, per mantenere la costanza di sviluppo, da rulli dosatori superiori, a mutandine da donna e simili in tessuti leggeri e medi. Dotata di coltelli rifilatori non disinnestabili per rifilare il tessuto. Con differenziale. Velocità max. 5200 g/1' - N. punti per poll. 9 ÷ 18	For attaching elastics and elastic lace, coming from a roll placed above and fed from top metering rollers which permit uniform feeding, to ladies' panties and the like in light and medium fabrics. Fitted with fixed trimming knives to trim fabric edge. With differential feed. Max speed 5200 r.p.m. - Stitch per inch. 9 ÷ 18	Pour appliquer des dentelles élastiques, provenant de rouleau placé en haut et alimentés par des rouleaux doseurs supérieur sur des culottes pour dames et articles similaires en tissu légers et moyens. Elle est équipée de couteaux raseurs non débrayables et de transport différentiel. Vitesse max 5200 t.p.m. - N. point par pouce 9 ÷ 18
261-34-2DR-26	Come la 261-34-2DR-25 ma con distanza aghi 4,5 mm e per applicare elastici larghi in cintura di slips e mutande in maglia da uomo. Con differenziale. Velocità max. 5200 g/1' - N. punti per poll. 9 ÷ 18	Same as 261-34-2DR-25, but with 4,5 mm needle gauge and for attaching wide elastics at the waist of men's briefs and knit underpants. With differential feed. Max speed 5200 r.p.m. - Stitch per inch. 9 ÷ 18	Comme la 261-34-2DR-25, mais avec écartement aiguilles 4,5 mm et pour appliquer des élastiques larges à la ceinture des slips et des caleçons en tissu à maille pour homme. Avec transport différentiel. Vitesse max 5200 t.p.m. - N. point par pouce 9 ÷ 18
261-34-2DR-28	Come la 261-34-2DR-26 ma con distanza aghi 6 mm. Velocità max. 5200 g/1' - N. punti per poll. 9 ÷ 18	Same as 261-34-2DR-26, but with 6 mm needle gauge. Max speed 5200 r.p.m. - Stitch per inch. 9 ÷ 18	Comme la 261-34-2DR-26, mais avec écartement d'aiguilles 6 mm. Vitesse max 5200 t.p.m. - N. point par pouce 9 ÷ 18
261-34-2DR-43	Come la 261-34-2DR-25 ma con distanza aghi 3 mm. Velocità max. 5200 g/1' - N. punti per poll. 9 ÷ 18	Same as 261-34-2DR-25, but with 3 mm needle gauge. Max speed 5200 r.p.m. - Stitch per inch. 9 ÷ 18	Comme la 261-34-2DR-25, mais avec écartement aiguilles 3 mm. Vitesse max 5200 t.p.m. - N. point par pouce 9 ÷ 18
261-34-3DR-18	Per applicare elastici larghi provenienti da rotolo dall'alto e alimentati, per mantenere la costanza di sviluppo, da rulli dosatori superiori, a slips o mutande in maglia da uomo. Dotata di coltelli rifilatori non disinnestabili per rifilare il tessuto. Con differenziale. Velocità max. 5200 g/1' - N. punti per poll. 9 ÷ 18	For attaching wide elastics, coming from a roll placed above, and fed from top metering rollers, which permit uniform tensioning, at the waist of men's briefs and knit underpants. Fitted with fixed trimming knives to trim fabric edge. With differential feed. Max speed 5200 r.p.m. - Stitch per inch. 9 ÷ 18	Pour appliquer des élastiques larges, provenant de rouleau placé en haut et alimentés par des rouleaux doseurs supérieurs aux slips ou aux caleçons à maille pour homme. Elle est dotée de couteaux raseurs non débrayables pour refiler le bord de tissu et avec transport différentiel. Vitesse max 5200 t.p.m. - N. point par pouce 9 ÷ 18
261-34-3DR-24	Come la 261-34-3DR-18 ma con distanza aghi 5 mm. Velocità max. 5200 g/1' - N. punti per poll. 9 ÷ 18	Same as 261-34-3DR-18 but with 5 mm needle gauge. Max. speed 5200 r.p.m. - Stitch per inch. 9 ÷ 18	Comme la 261-34-3DR-18, mais avec écartement aiguilles 5 mm. Vitesse max 5200 t.p.m. - N. point par pouce 9 ÷ 18
261-34-3DR-55	Per applicare elastici e pizzi elastici a collant su telaio Eppinger in un unico pezzo con un punto chiuso dal telaio stesso e con apertura giro a vita pure prodotta da telaio. Con differenziale e con coltelli rifilatori disinnestabili. Con rulli dosatori superiori e senza rulli trasportatori. Velocità max. 5200 g/1' - N. punti per pollice 9 ÷ 18	For attaching elastics and elastic lace to tights produced in one operation on Eppinger looms, finished with a "non-run" border, with the waist opening already knitted on the loom. With differential feed and with disengageable trimming knives, with top metering rollers, without rear puller feed rollers. Max speed 5200 r.p.m. - Stitch per inch. 9 ÷ 18	Pour appliquer des élastiques et des dentelles élastiques aux collants produits sur métier type Eppinger en une seule pièce terminant avec des points en indémaillable et avec couverture de la taille formée par le métier. Avec rouleaux doseurs supérieurs, sans, rouleaux transporteurs. Avec transport différentiel et couteaux raseurs débrayables. Vitesse max 5200 t.p.m. - N. point par pouce 9 ÷ 18

**INDICE NUMERICO      INDEX**

Part. N.	Tav. N.	Part. N.	Tav. N.	Part. N.	Tav. N.	Part. N.	Tav. N.	Part. N.	Tav. N.	Part. N.	Tav. N.	Part. N.	Tav. N.
200324-0-10	2	300391-0-10	2	302355-0-10	3	303503-0-10	8	304480-0-00	6	308057-0-00	11	308166-0-00	5
200413-2-10	12	300419-0-10	16	302356-0-10	1	303538-0-00	8	304481-4-00	6	308058-0-00	11	308174-3-00	5
200678-0-10	6	300420-0-10	16	302590-4-10	10	303539-0-00	8	304763-0-10	14	308059-0-00	11	308178-4-00	5
200710-0-10	14	300469-2-11	8	302591-0-10	10	303899-0-10	10	304767-2-10	11	308060-4-00	11	308180-2-00	16
200714-0-10	14	300482-0-10	8-9	302708-0-01	13	304073-0-10	12	305170-0-01	4	308061-0-01	11	308184-0-00	16
201143-0-10	4	300483-0-10	2-3	302762-0-10	17	304084-0-10	12	305172-0-00	4	308062-2-00	14	308185-0-00	16
201358-0-10	12	301458-0-10	4	302764-2-10	17	304085-4-10	12	305194-0-00	9	308084-2-00	5	308190-0-00	4
202032-0-11	10	301459-4-10	4	302765-4-10	17	304086-0-10	12	305670-2-00	13	308086-0-10	1	308191-4-00	4
202165-0-10	3	301519-2-11	4	302766-0-10	17	304406-0-11	6	305671-2-00	13	308094-0-00	1	308192-4-01	4
202229-0-10	14	301523-0-10	12	302767-0-10	17	304412-0-10	6	306679-3-00	17	308098-0-00	11	308193-2-00	4
202239-0-10	3	301527-0-10	12	302768-0-10	17	304413-0-10	6	307664-0-00	1	308101-2-00	3	308194-0-01	4
202398-0-10	1	301579-0-10	4	302769-0-10	17	304423-4-21	12	307739-0-00	1	208102-0-00	3	308195-0-00	4
202474-0-10	8	301596-0-11	17	302770-0-10	17	304424-0-10	12	308002-0-00	15	308103-4-10	3	308196-0-10	4
202486-0-10	4	301598-0-11	17	302773-0-11	17	304430-0-10	12	308005-0-00	10	308104-0-00	16	308201-0-01	2
202556-0-00	14	302028-0-12	4	302796-0-10	17	304431-4-11	12	308006-4-00	10	308105-4-01	16	308203-0-01	2
202558-2-00	14	302052-2-21	8	302798-0-10	17	304432-4-10	12	308007-0-00	11	308110-3-01	16	308207-0-00	16
203928-0-10	12	302057-0-11	17	302801-3-11	13	304436-0-10	12	308009-0-00	1	308111-0-00	16	308211-0-00	16
203949-0-10	12	302059-0-10	11	302803-0-10	13	304437-0-10	12	308012-2-01	5	308113-0-00	15	308212-0-00	16
206545-0-00	15	302060-0-11	11	302804-2-10	13	304438-0-10	12	308013-4-01	5	308114-2-01	16	308214-0-00	16
206555-0-01	16	302064-0-10	2	302806-0-10	13	304441-0-10	12	308015-0-00	7	308119-0-00	4	308215-0-00	1
206557-0-00	16	302136-0-12	2	302807-0-10	13	304445-0-11	6	308029-2-00	4	308123-0-00	16	308218-0-00	1
206559-0-00	15	302149-0-11	2	302808-0-10	13	304449-4-20	6	308030-2-00	4	308125-0-00	15	308219-0-00	16
206560-0-10	15	302150-0-10	6	302811-0-10	17	304453-2-10	12	308031-0-00	1	308127-0-00	5	308220-0-00	10
206564-0-00	15	302151-0-10	6	302812-0-10	13	304456-0-11	12	308032-0-00	1	308128-0-00	3	308226-0-02	15
206583-0-00	10	302152-0-10	4	302813-4-10	13	304457-0-10	12	308036-2-00	10	308129-0-00	3	308228-2-00	15
206669-2-02	16	302168-2-10	2	302821-0-10	17	304458-0-10	12	308037-0-00	10	308137-0-00	2	308231-2-01	15
300006-0-11	3	302172-0-10	2	302840-0-10	13	304459-0-10	12	308038-0-10	10	308138-0-11	1	308232-0-00	1
300119-0-11	17	302204-0-10	2	302844-3-10	13	304460-0-10	12	308039-0-01	10	308139-2-01	10	308234-2-00	10
300120-0-10	17	302232-0-10	14	302846-0-10	13	304462-0-20	6	308040-2-00	16	308140-0-00	8	308235-0-00	10
300209-0-10	4	302234-0-10	11	302851-2-10	17	304463-0-10	12	308041-0-00	10	308142-0-00	8	308236-2-01	10
300218-0-10	14	302238-0-10	14	302857-0-10	13	304467-4-11	12	308042-0-00	10	308147-0-00	12	308238-4-00	10
300228-0-10	4	302272-0-10	5	302859-0-10	13	304468-2-20	12	308043-0-00	16	308148-0-00	11	308239-0-00	10
300231-0-20	4	302276-0-10	8	302864-0-10	13	304469-0-11	12	308044-0-00	9	308149-0-01	5	308243-3-00	16
300310-0-10	2	302289-0-10	9	302865-0-10	13	304471-2-10	12	308045-0-01	9	308150-0-10	15	308244-4-00	10
300351-0-11	9	302292-0-10	10	302866-0-10	13	304472-0-10	12	308046-2-01	9	308151-0-00	15	308254-3-00	5
300352-0-10	9	302338-0-10	10	302869-0-10	13	304473-4-10	12	308047-0-00	9	308153-0-00	16	308261-4-00	8
300361-0-11	4	302344-0-10	11	303045-0-10	2	304474-0-10	12	308050-2-00	8	308154-0-00	16	308266-2-01	8
300362-0-11	4	302349-0-10	6	303052-0-00	17	304475-0-10	12	308052-4-00	11	308155-4-01	16	308271-0-01	8
300364-0-10	4	302352-0-10	10	303458-0-12	7	304476-0-11	6	308054-0-01	11	308159-2-01	5	308272-0-00	8
300371-0-10	4	302353-0-10	3	303459-2-11	4	304477-0-01	12	308055-2-00	11	308161-0-00	5	308273-0-00	8
300377-0-10	4	302354-0-10	3	303501-0-10	1	304478-0-00	12	308056-0-01	11	308162-0-00	5	308275-2-00	4

INDICE NUMERICO INDEX

Part. N.	Tav. N.	Part. N.	Tav. N.	Part. N.	Tav. N.	Part. N.	Tav. N.	Part. N.	Tav. N.	Part. N.	Tav. N.	Part. N.	Tav. N.
308276-0-10	4	308532-4-00	14	309372-0-00	3	704240-2-00	14	721444-2-00	1-2-4	730061-2-00	6	742282-2-00	3
308278-0-01	7	308551-0-00	2	309373-2-00	13	704302-4-00	2	721464-2-00	15	731086-0-00	19	742311-2-00	10
308281-0-00	7	308553-2-00	2	309380-4-01	13	704306-0-00	3	721474-2-00	3-17	731107-2-00	17-21	742423-0-00	8
308283-2-00	4	308556-0-00	2	309560-0-00	4	704309-4-00	9	721475-2-00	6-13-20	733504-2-00	17	742811-0-00	4-12
308285-0-00	4	308558-0-00	2	309572-4-01	4	704310-2-00	19-20	721485-2-00	1-8	733507-0-00	16	742813-0-00	4
308286-4-00	4	308577-2-10	15	309712-4-02	7	704316-2-00	19-20	721494-2-00	11-17	733508-2-00	21	743134-2-00	17
308287-0-00	4	308589-4-03	15	309750-2-00	10	704345-2-00	19-20	721514-0-00	16	733508-4-00	19-20	743243-2-00	13
308289-2-00	4	308615-3-10	1	309771-0-00	10	704346-2-00	19-20	722411-2-00	12	733510-4-00	19-20	743482-2-00	6
308292-4-00	8	308715-3-02	7	309803-4-00	10	704347-2-00	4	722422-2-00	10	733813-0-00	19-20	743541-2-00	19-20
308293-0-01	1	308762-2-00	13	309830-2-00	10	704406-0-00	4	722431-2-00	21	740034-2-00	14	744040-2-00	9
308295-0-00	16	308774-2-00	7	309831-2-00	10	704409-0-00	6	722433-2-00	12	740210-2-00	2	744332-2-00	11
308296-0-00	1	308780-2-00	7	309838-2-00	4	704409-2-00	20	722453-2-00	15	740220-2-00	2-12	744334-2-00	10
308297-0-00	1	308783-2-00	3	309839-2-00	4	704805-0-00	4	722454-2-00	13	740226-0-00	8	744553-0-00	12
308298-0-00	1	308802-0-00	5	310040-4-00	17	704813-0-00	16	722483-2-00	12	740240-0-00	15	744587-2-00	14
308301-0-00	6	308851-2-01	10	310043-4-00	17	704814-0-00	7	722905-2-00	19	740243-0-00	4	744636-2-00	3
308310-0-00	5	308852-0-00	1	310353-4-00	5	704828-0-00	10	722907-2-00	20	740257-0-00	4	744656-2-00	3
308320-4-00	14	308853-0-00	1	310500-4-00	16	704841-0-00	12	722920-2-00	20	740444-2-00	11	744676-2-00	9
308321-0-00	14	308855-0-00	5-10	311098-0-00	2	704846-0-00	4-8	724420-2-00	2	740475-2-00	4	744730-0-00	3
308325-3-00	9	308858-0-00	1	311395-0-00	15	704849-0-00	9	724441-0-00	7	740632-2-00	11-14	745001-0-00	10
308326-2-01	9	308859-2-00	1	700205-0-00	11	704869-0-00	5-10	724471-0-00	12	741056-0-00	5	745002-0-00	12
308327-0-00	9	308934-4-00	2	700208-0-00	19-20	705013-0-00	5-10	724908-2-00	6	741082-2-00	16	745114-0-00	13
308330-3-00	9	308967-2-00	4	700210-0-00	13	705201-0-00	2	727014-2-00	12	741088-2-00	3-6	745126-2-00	14
308332-4-00	9	308971-3-00	4	700212-0-00	12	705208-0-00	10	727056-0-00	13	741092-0-00	16	745136-2-00	4
308333-0-01	9	308996-0-01	14	700596-0-00	5	705734-0-00	8	727082-0-00	12	741403-0-00	12	745317-0-00	6
308340-4-00	4	309042-2-00	3	701004-0-00	16	705834-0-00	9	727215-0-00	4	741413-2-00	2-17	745810-2-00	10
308346-5-01	4	309059-4-00	3	701007-0-00	14	705970-0-00	3	727834-2-00	14	741414-2-00	17	745812-2-00	5-10-12
308362-4-01	7	309084-0-00	3	701009-0-00	9	705977-0-00	15	728232-0-00	4	741546-2-00	4	745815-2-00	4-5-8-9
308385-2-01	7	309086-0-01	3	701032-0-00	16	706285-0-00	1	729011-2-00	2-4	741611-2-00	10	745827-2-00	7-11
308406-0-00	1	309088-0-00	3	701051-0-00	15	706434-0-00	4	729013-2-00	4-10-13	741612-0-00	2	746002-2-00	12
308412-2-01	11	309126-3-00	3	702403-0-00	8	706454-0-00	1	729024-2-00	17	741642-2-00	2-13	746008-0-00	10
308496-2-00	14	309139-4-00	3	703003-0-00	15	707240-0-00	11	729032-2-00	1	741658-2-00	3	746021-2-00	17
308501-0-01	14	309155-0-00	3	703005-0-00	10-21	707241-0-00	14	729034-2-00	14-21	741675-2-00	9	746204-0-00	14
308502-0-00	14	309205-3-00	3	703208-0-00	13	720411-2-00	3	729043-2-00	12	741682-0-00	2	746204-2-00	13
308503-0-01	14	309229-0-00	3	703810-0-00	8	720464-0-00	19-20	729044-2-00	6	741721-2-00	6	746404-0-00	4
308504-0-00	14	309249-0-00	3	703825-0-00	13	720505-4-00	19-20	729054-2-00	17-21	741724-0-00	8	746408-2-00	5-10
308505-0-00	14	309302-2-00	3	704009-4-00	19-20	720545-4-00	19-20	729434-2-00	9	741781-2-00	17	746409-2-00	19-20
308506-0-00	14	309323-0-00	3	704210-4-00	2-10	720546-0-00	20	729884-2-00	14	741925-2-00	3	746612-2-00	7
308507-0-00	14	309324-2-10	3	704216-2-00	12	721411-2-00	17	733008-2-00	19-20	741928-0-00	4	766000-6-80	10
308513-0-00	14	309351-0-00	3	704218-2-00	2-4	721412-2-00	12-13	730011-2-00	16	741936-2-00	3	778203-0-00	10
308518-4-00	14	309360-0-00	3	704226-2-00	8	721424-2-00	16	730023-2-00	13	742214-2-00	8	778238-0-00	4
308521-4-00	14	309371-0-00	3	704236-2-00	11	721434-2-00	17-20	730033-2-00	8-10	742222-2-00	5	778240-0-00	16

INDICE NUMERICO INDEX

Part. N.	Tav. N.	Part. N.	Tav. N.	Part. N.	Tav. N.	Part. N.	Tav. N.	Part. N.	Tav. N.	Part. N.	Tav. N.	Part. N.	Tav. N.
778407-0-00	10	990593-0-11	17										
778412-0-00	4	990594-2-00	17										
778461-0-00	15	990596-0-10	17										
778522-0-00	4	990674-0-00	19-20										
778827-0-00	8	990675-0-10	19										
784364-0-20	17	990689-2-00	20										
788020-0-01	3	990694-0-11	19										
790242-0-00	16	990703-0-11	17										
790307-0-00	16	990704-0-11	17										
790315-0-00	16	990705-4-11	17										
790325-0-00	16	990707-2-10	17										
790342-0-00	16	990708-0-10	17										
900201-0-10	19	990709-4-12	17										
900203-0-10	19-20	990808-0-01	17										
900204-0-10	20	990926-0-00	20										
900918-0-00	19-20	990982-0-00	19-20										
900920-0-00	19-20	991106-2-00	21										
900925-4-01	19-20	991107-2-00	21										
900926-0-00	19	991108-2-00	21										
900927-0-00	19-20	991111-2-00	21										
900928-0-00	19-20	991112-0-00	21										
900929-0-01	19-20	991113-0-00	21										
900931-0-00	19-20	991114-2-00	17-21										
901101-0-00	19-20	991120-5-00	21										
901102-0-00	19-20	991121-3-00	21										
901253-0-00	20	991128-2-00	21										
901255-2-00	20	991129-3-00	21										
925433-0-00	21	991153-2-00	17										
930096-0-10	17	991179-0-00	21										
990075-1-13	18	991250-0-00	19-20										
990175-0-10	18	991251-4-00	19										
990176-0-10	18	991252-4-00	20										
990179-4-11	19-20	991253-4-00	19										
990181-0-10	18	991254-4-00	20										
990182-0-10	18	991255-0-00	19-20										
990188-0-10	18	991256-0-00	19-20										
990193-0-00	18	991257-0-00	19-20										
990317-0-10	19	991259-3-00	19-20										
990474-0-11	18	991408-4-00	18										
990578-0-12	18	991415-0-00	18										
990587-0-10	18												



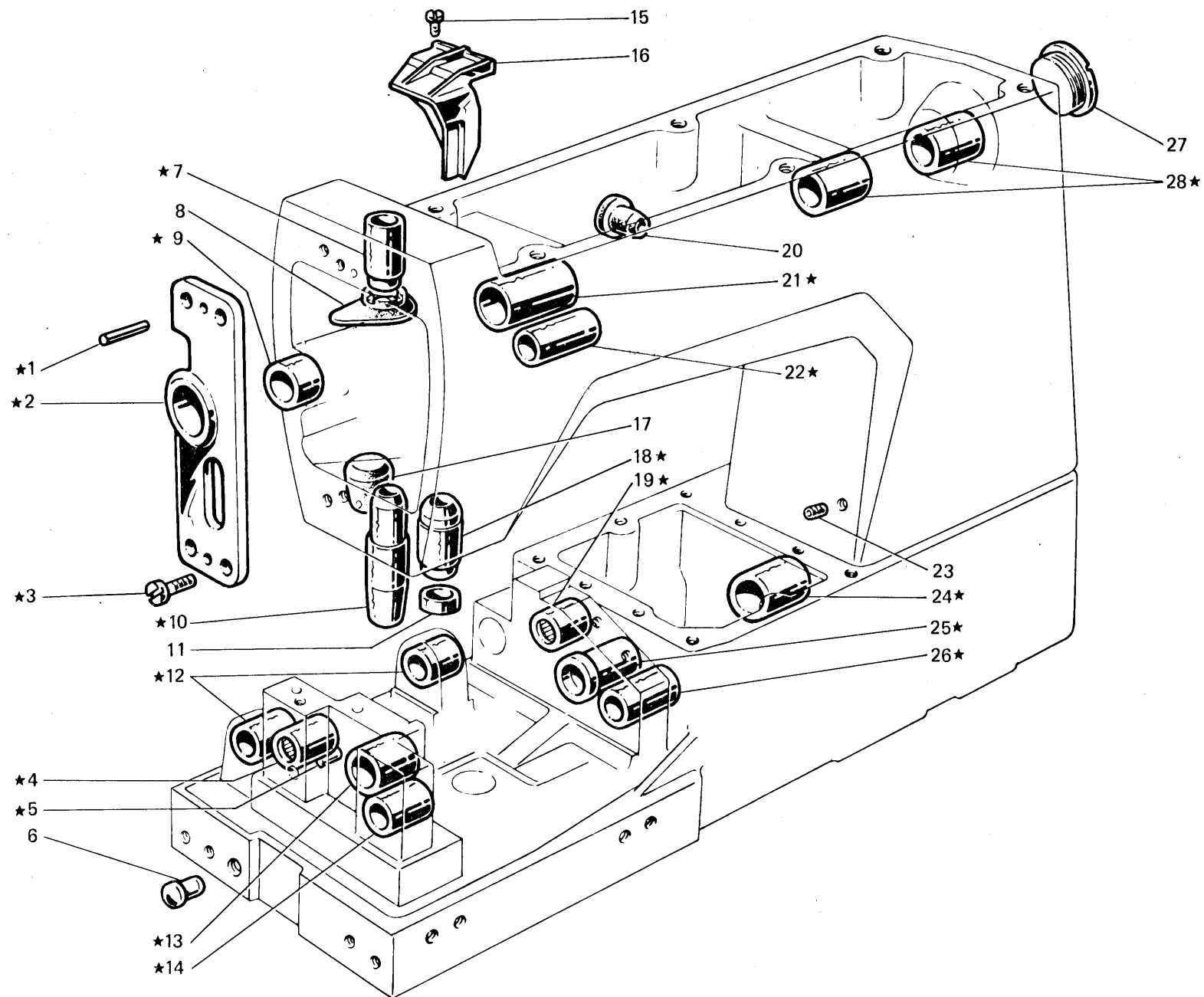

Fig. N. Abb. N.	Part. N. Piece N. Bestell N. Pieza N.	Qt. Anzahl	DESCRIZIONE	DESCRIPTION	DESCRIPTION	BENENNUNG	DESCRIPCION
★	308615-3-10	1	base e braccio con bussola	base and arm with bushes	base et bras avec bague		
1	706454-0-00	2	spina	pin	goupille		
2	308859-2-00	1	supporto con bussola fig. 9	support with bush fig. 9	support avec bague fig. 9		
3	721485-2-00	4	vite	screw	vis		
4	307664-0-00	1	bussola	bush	bague		
5	706285-0-00	1	spina	pin	goupille		
6	202398-0-10	1	tappo	plug	bouchon		
7	308032-0-00	1	bussola	bush	bague		
8	308215-0-00	1	protezione olio	oil protection	protection huile		
9	308858-0-00	1	bussola	bush	bague		
10	308406-0-00	1	bussola	bush	bague		
11	308218-0-00	1	scodellino inferiore	lower cup	cuvette inférieur		
12	308296-0-00	2	bussola	bush	bague		
13	308293-0-01	1	bussola	bush	bague		
14	308297-0-00	1	bussola	bush	bague		
15	721444-2-00	1	vite	screw	vis		
16	308138-0-11	1	carter paraolio	oil retainer cover	carter pare-huile		
17	308094-0-00	1	tappo foro bussola	plug	bouchon		
18	308031-0-00	1	bussola	bush	bague		
19	307739-0-00	1	bussola	bush	bague		
20	303501-0-10	1	tappo per foro tendifilo	plug	bouchon		
21	308852-0-00	1	bussola	bush	bague		
22	308232-0-00	1	bussola	bush	bague		
23	729032-2-00	1	vite	screw	vis		
24	308086-0-10	1	bussola	bush	bague		
25	308009-0-00	1	bussola	bush	bague		
26	308298-0-00	1	bussola	bush	bague		
27	302356-0-10	1	tappo	plug	bouchon		
28	308853-0-00	2	bussola	bush	bague		

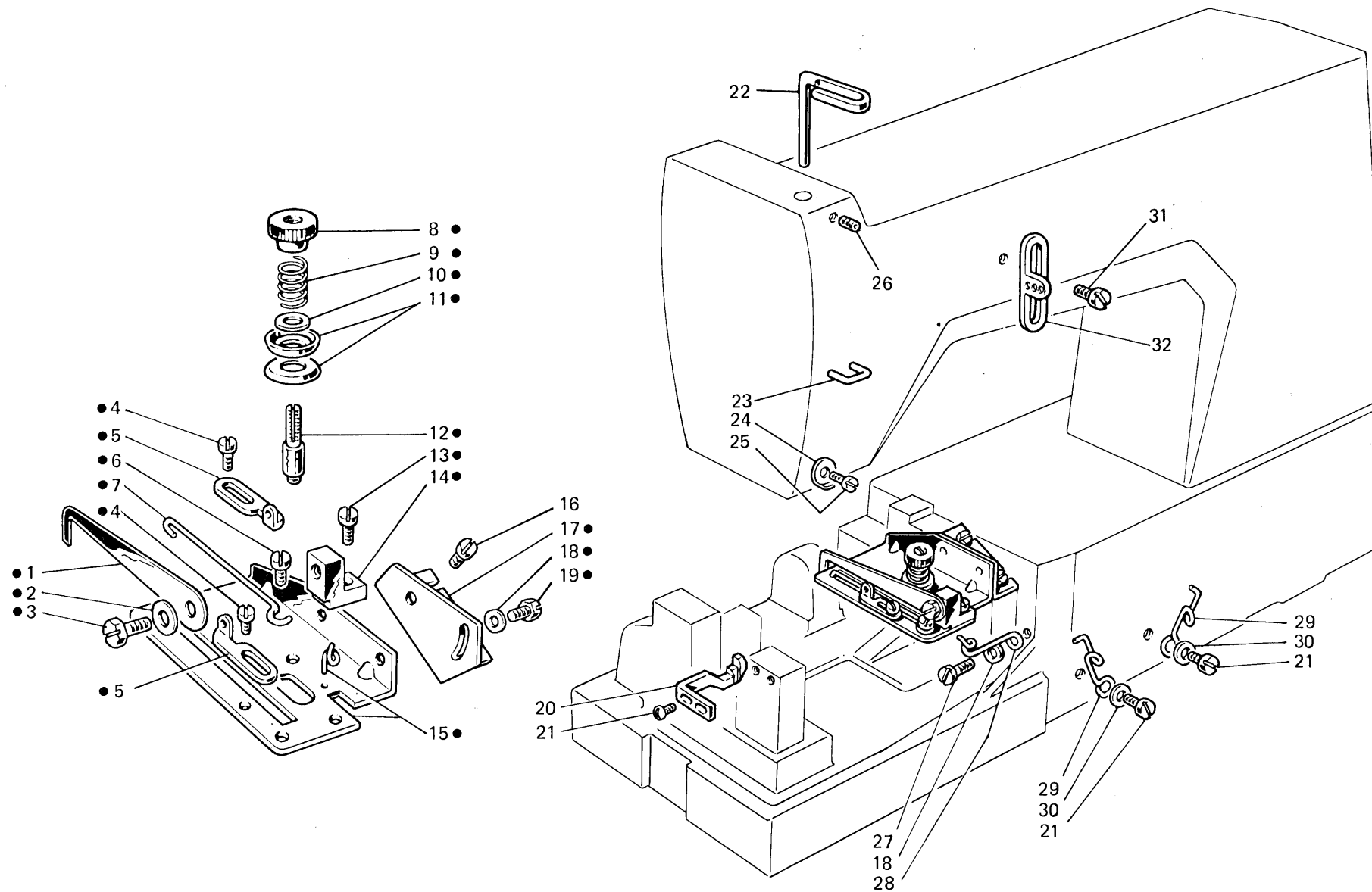

Fig. N. Abb. N.	Part. N. Piec. N. Bestell N. Pieza N.	Qt. Anzahl	DESCRIZIONE	DESCRIPTION	DESCRIPTION	BENENNUNG	DESCRIPCION
●	308934-4-00	1	gruppo tensione crochet infer.	tension assembly for lower looper	groupe tension crochet inférieur		
1	308556-0-00	1	astina	rod	tige		
2	705201-0-00	1	rondella	washer	rondelle		
3	740220-2-00	1	vite	screw	vis		
4	741413-2-00	2	vite	screw	vis		
5	302172-0-10	2	passafilo	thread guide	passe-fil		
6	741612-0-00	1	vite	screw	vis		
7	308558-0-00	1	traversino	tie-rod	traverse		
8	302204-0-10	1	pomolo	knob	pommeau		
9	300310-0-10	1	molla	spring	ressort		
10	704218-2-00	1	rondella	washer	rondelle		
11	200324-0-10	2	disco tensione	tension disc	disque tension		
12	300391-0-10	1	perno a vite	threaded pin	pivot à vis		
13	741642-2-00	1	vite	screw	vis		
14	302168-2-10	1	supporto	support	support		
15	308553-2-00	1	piastra	plate	plaque		
16	721444-2-00	2	vite	screw	vis		
17	308551-0-00	1	squadretta	bracket	équerre		
18	704302-4-00	3	rondella	washer	rondelle		
19	740210-2-00	2	vite	screw	vis		
20	302064-0-10	1	salva ago	needle guard	protège aiguille		
21	300483-0-10	4	vite	screw	vis		
22	302136-0-12	1	passafilo	thread guide	passe-fil		
23	308137-0-00	1	cavallotto	coupling	cavalier		
24	308201-0-01	1	passafilo	thread guide	passe-fil		
25	724420-2-00	1	vite	screw	vis		
26	729011-2-00	1	vite	screw	vis		
27	741682-0-00	1	vite	screw	vis		
28	302149-0-11	1	passafilo	thread guide	passe-fil		
29	311098-0-00	2	passafilo	thread guide	passe-fil		
30	704210-4-00	2	rondella	washer	rondelle		
31	303045-0-10	2	vite	screw	vis		
32	308203-0-01	2	guidafilo	thread guide	guide-fil		

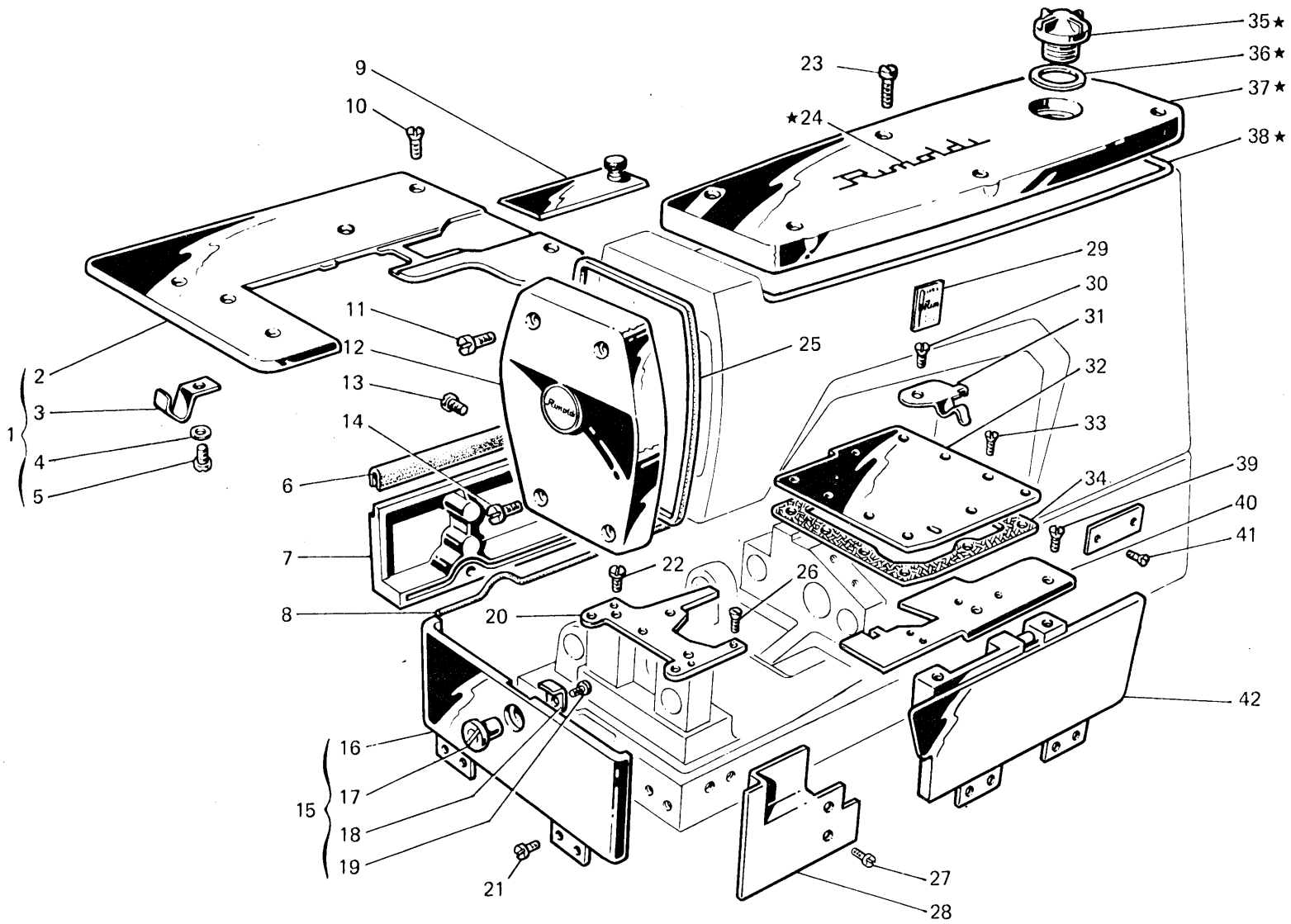

Fig. N. Abb. N.	Part. N. Piece N. Bestell N. Pieza N.	Qt. Anzahl	DESCRIZIONE	DESCRIPTION	DESCRIPTION	BENENNUNG	DESCRIPCION
★	308103-4-10	1	coperchio superiore compl.	upper cover assembly			
1	309059-4-00	1	piano di lavoro compl.	working plate assembly	couvercle supérieur compl.		
2	309042-2-00	1	piano di lavoro	working plate	plan de travail complet		
3	309351-0-00	1	molla	spring	plan de travail		
4	704306-0-00	1	rondella	washer	ressort		
5	720411-2-00	1	vite	screw	rondelle		
6	309088-0-00	1	guarnizione	gasket	vis		
7	309086-0-01	1	carter posteriore	rear cover	garniture		
8	309084-0-00	1	guarnizione	gasket	carter anrière		
9	309302-2-00	1	coperchio scorrevole	sliding cover	gasket		
10	744638-2-00	5	vite	screw	couvercle coulissant		
11	302354-0-10	2	vite superiore	upper screw	vis		
12	308101-2-00	1	coperchio laterale	slide cover	vis supérieure		
13	741088-2-00	3	vite per carter posteriore	screw for rear cover	couvercle latéral		
14	302353-0-10	2	vite inferiore	lower screw	vis pour carter arrière		
15	309139-4-00	1	carter laterale completo	side cover assembly	vis inférieur		
16	309126-3-00	1	carter laterale	side cover	carter latéral complet		
17	309372-0-00	1	perno	pin	carter latéral		
18	309371-0-00	1	chiavistello	key	pivot		
19	741658-2-00	1	vite	screw	clé		
20	308783-2-00	1	piastra porta placca	plate	vis		
21	300483-0-10	8	vite per cerniera	screw for hinge	plaque		
22	302355-0-10	2	vite per piastra	screw for plate	vis pour charnière		
23	742282-2-00	6	vite per coperchio	screw for cover	vis pour plaque		
24	300006-0-11	2	decalcomania	decalcomania	vis pour couvercle		
25	308128-0-00	1	guarnizione coperchio	cover gasket	décalcomanie		
26	744730-0-00	2	vite per placca ago	screw for needle plate	garniture couvercle		
27	741925-2-00	2	vite	screw	vis pour plaque aiguille		
28	309155-0-00	1	semicarter anteriore sinistro	front left cover	vis		
29	788020-0-01	1	decalcomania sistema aghi	needles decalcomania	carter avant gauche		
30	721474-2-00	1	vite	screw	décalcomanie system aiguilles		
31	309360-0-00	1	molla chiusura carter	spring	vis		
32	309324-2-10	1	piastra superiore	upper plate	ressort		
33	741938-2-00	9	vite per piastra	screw for plate	plaque supérieure		
34	309323-0-00	1	guarnizione	gasket	vis pour plaque		
35	202239-0-10	1	cupolina	cup	garniture		
36	705970-0-00	1	guarnizione per cupolina	gasket	coupole		
37	308102-0-00	1	coperchio superiore	upper cover	garniture		
38	308129-0-00	1	guarnizione per coperchio	gasket for cover	couvercle supérieur		
39	744656-2-00	2	vite	screw	garniture pour couvercle		
40	309229-0-00	1	piastra piano di lavoro	working plate	vis		
41	202165-0-10	2	vite per targhetta	screw for plate	plaque plan de travail		
42	309205-3-00	1	carter anteriore	front cover assembly	vis pour plaquette		
40	309249-0-00	1	SOLO A RICHIESTA piastra piano di lavoro	ONLY ON REQUEST plate	SEULEMENT SUR DEMANDE plaque plan de travail		

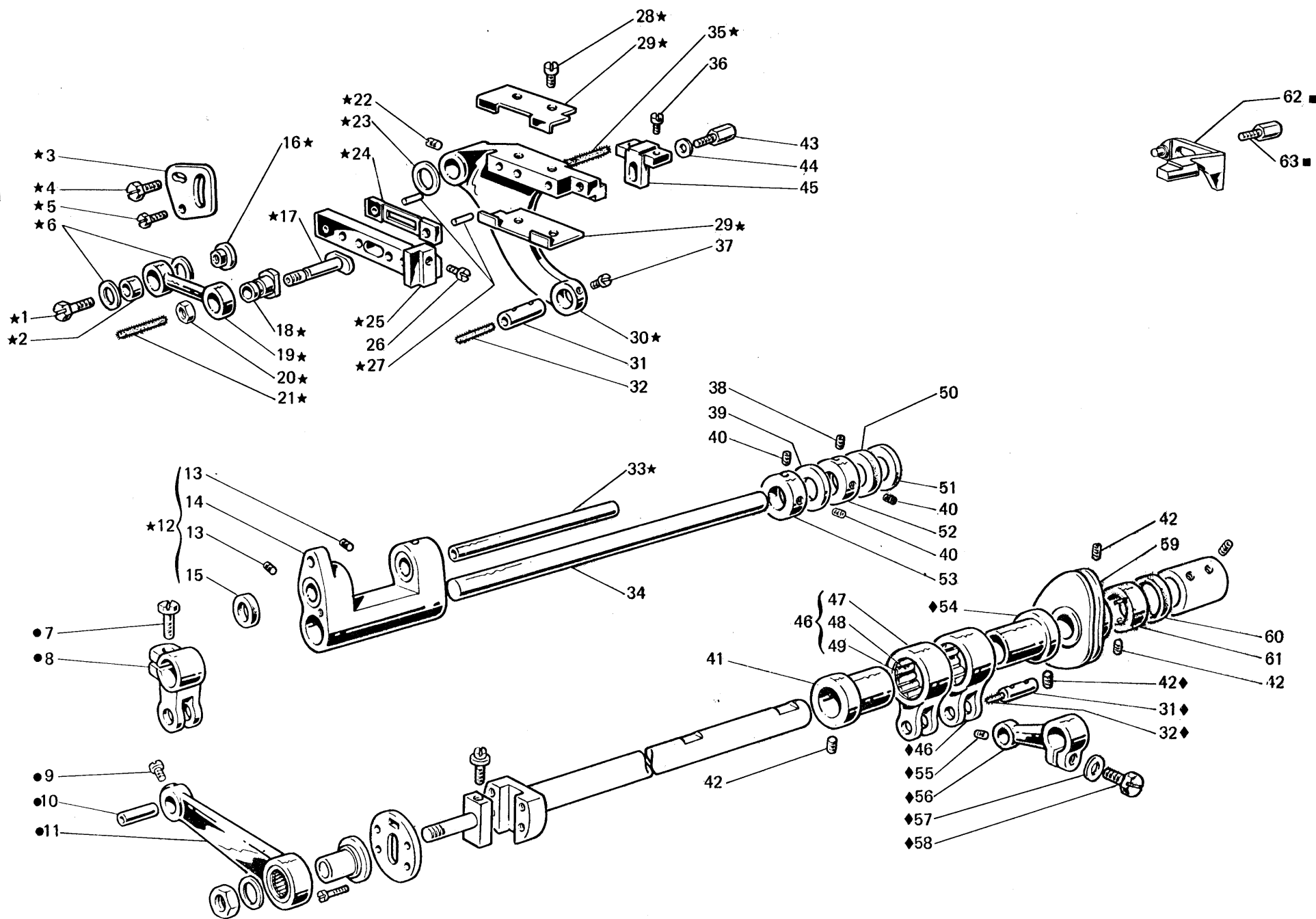

Fig. N. Abb. N.	Part. N. Piec. N. Bestell N. Pieza N.	Qt. Anzahl	DESCRIZIONE	DESCRIPTION	DESCRIPTION	BENENNUNG	DESCRIPCION
—	308346-5-01	1	gruppo porta griffa completa (con★-31-32-37-41-42-46)	feed dog holder assembly (with★-31-32-37-41-42-46)	groupe porte-griffe (avec★-31-32-37-41-42-46)		
★	308192-4-01	1	gruppo porta griffa	feed dog holder assembly	groupe porte-griffe		
●	308286-4-00	1	gruppo leva	lever assembly	groupe levier		
◆	308340-4-00	1	gruppo comando crochet	looper control assembly	groupe commande crochet		
1	740475-2-00	1	vite	screw	vis		
2	300228-0-10	1	bussola	bush	bague		
3	308194-0-01	1	settore	sector	secteur		
4	740257-0-00	1	vite	screw	vis		
5	740243-0-00	1	vite	screw	vis		
6	704805-0-00	2	rondella	washer	rondelle		
7	202486-0-10	1	vite	screw	vis		
8	301519-2-11	1	attacco	clamp	raccord		
9	742813-0-00	1	vite	screw	vis		
10	308285-0-00	1	perno	pin	pivot		
11	308283-2-00	1	leva comando porta griffa	lever	levier		
12	308191-4-00	1	supporto oscillante compl.	oscillating support assembly	support coulissant complet		
13	729013-2-00	2	vite	screw	vis		
14	308193-2-00	1	supporto con viti	support with screws	support avec vis		
15	308190-0-00	2	anello di tenuta	retainer ring	bague d'étanchéité		
16	300362-0-11	1	cursore	slider	courseur		
17	308276-0-10	1	vite	screw	vis		
18	308196-0-10	1	bussola	bush	bague		
19	308275-2-00	1	biella	con-rod	bielle		
20	746404-0-00	1	dado	nut	écrou		
21	778412-0-00	1	stoppino	wick	mèche		
22	745815-2-00	1	vite	screw	vis		
23	309560-0-00	2	rondella	washer	rondelle		
24	300361-0-11	1	piastrina	plate	plaque		
25	300231-0-20	1	slitta porta griffa	feed dog slide	glissière porte griffe		
26	721444-2-00	1	vite fissa griffa	screw	vis		
27	706434-0-00	2	spina	pin	goupille		
28	741928-0-00	4	vite	screw	vis		
29	300371-0-10	2	squadretta	bracket	équerre		
30	302028-0-12	1	braccio porta griffa	feed dog arm	bras porte-griffe		
31	300209-0-10	2	perno	pin	pivot		
32	778238-0-00	2	stoppino	wick	mèche		
33	308195-0-00	1	perno	pin	pivot		
34	308289-2-00	1	perno per supporto oscillante	pin	pivot		
35	778522-0-00	1	stoppino	wick	mèche		
36	741546-2-00	2	vite fissa griffa	screw	vis		
37	742811-0-00	1	vite	screw	vis		
38	728232-0-00	1	vite	screw	vis		
39	704846-0-00	1	rondella	washer	rondelle		
40	745136-2-00	3	vite	screw	vis		
41	308030-2-00	1	eccentrico con viti fig.42	eccentric with screw fig.42	excentrique avec vis fig.42		
42	727215-0-00	7	vite	screw	vis		
43	302152-0-10	1	vite	screw	vis		
44	704406-0-00	1	rondella	washer	rondelle		



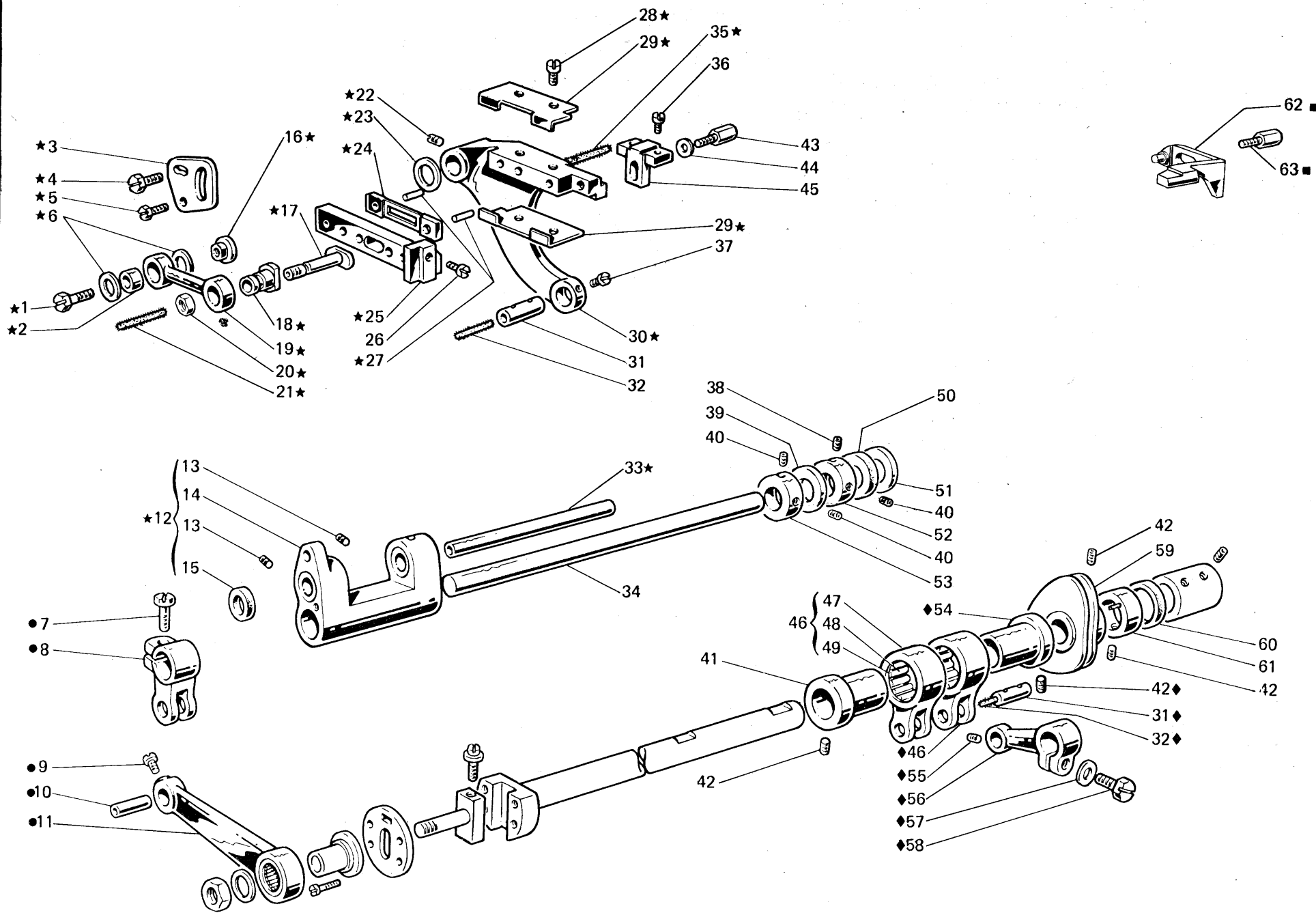

Fig. N. Abb. N.	Part. N. Piece N. Bestell N. Pieza N.	Qt. Anzahl	DESCRIZIONE	DESCRIPTION	DESCRIPTION	BENENNUNG	DESCRIPCION
45	300364-0-10	1	squadretta	bracket	équerre		
46	301459-4-10	2	giunto compl.per eccentrico	joint assembly for eccentric	joint compl.pour excentrique		
47	301458-0-10	2	giunto	joint	joint		
48	301579-0-10	2	gabbia a rullini	needles cage	cage à aiguilles		
49	201143-0-10	4	anello di tenuta	circlip	circlip		
50	308287-0-00	1	anello di tenuta	retainer ring	bague d'étanchéité		
51	704347-2-00	1	rondella	washer	rondelle		
52	309839-2-00	1	anello di registro	adjustment ring	bague de réglage		
53	309838-2-00	1	anello di registro	adjustment ring	bague de réglage		
54	308029-2-00	1	eccentrico con viti fig.42	eccentric with screws fig.42	excentrique avec vis fig.42		
55	729011-2-00	1	vite	screw	vis		
56	303459-2-11	1	braccio	arm	bras		
57	704218-2-00	1	rondella	washer	rondelle		
58	300377-0-10	1	vite	screw	vis		
59	308971-3-00	1	tendifilo a camma con viti	cam thread take-up with screws	tendeur du fil à came avec vis		
60	308119-0-00	1	anello di tenuta	retainer ring	bague d'étanchéité		
61	308967-2-00	1	anello limitatore	limiter ring	bague		
			<b>SOLO A RICHIESTA</b>	<b>ONLY ON REQUEST</b>	<b>SEULEMENT SUR DEMANDE</b>		
■	309572-4-01	1	gruppo salva ago	rear needle guard assembly	groupe protège-aiguille		
62	305170-0-01	1	salva ago	rear needle guard	protège-aiguille		
63	305172-0-00	1	vite	screw	vis		

M.C.C. = 163  
 Base     98.5  
 -----  
 l = 181.5

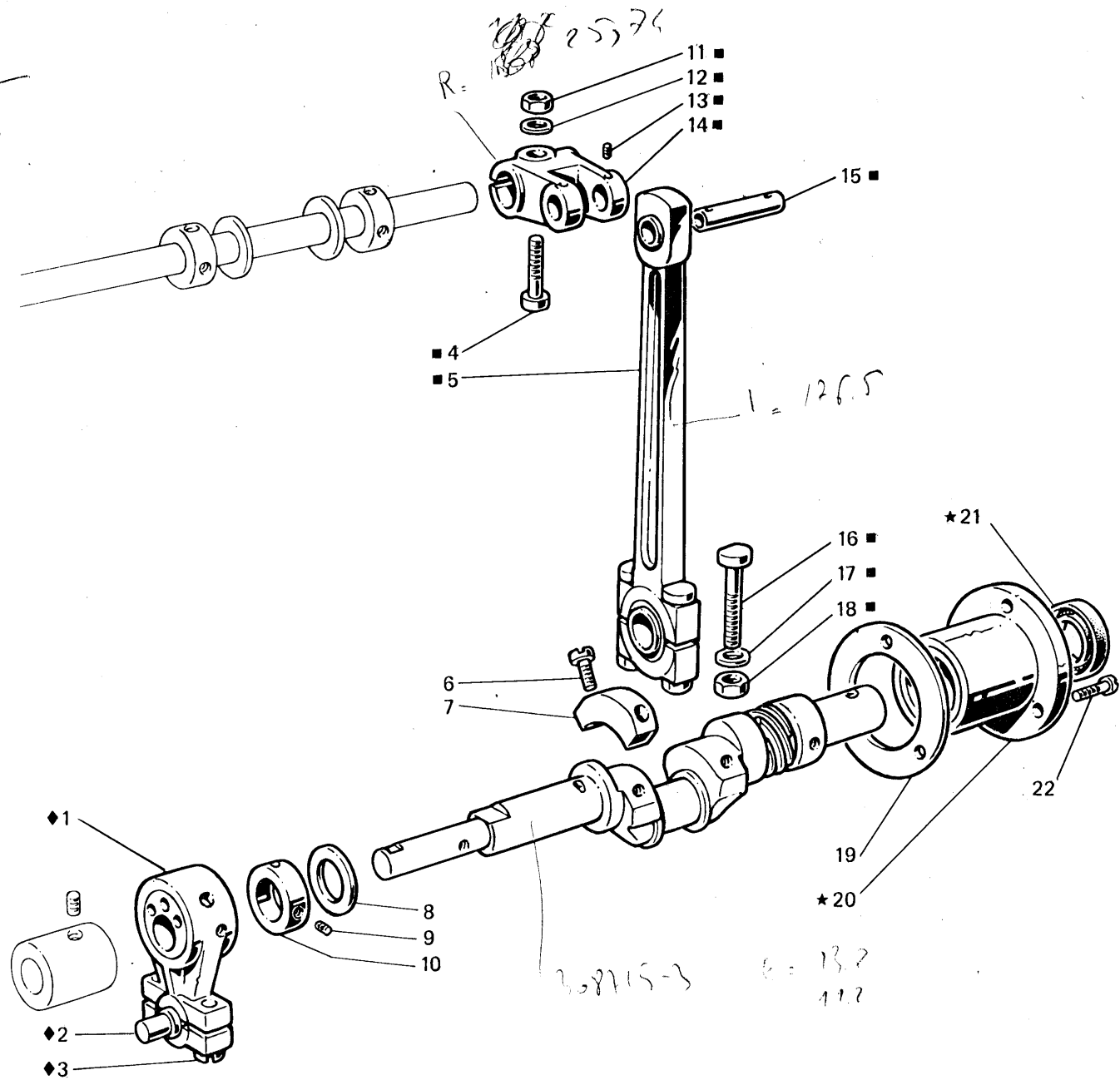

Fig. N. Abb. N.	Part. N. Piece N. Bestell N. Pieza N.	Qt. Anzahl	DESCRIZIONE	DESCRIPTION	DESCRIPTION	BENENNUNG	DESCRIPCION
★	308013-4-01	1	bussola destra completa	right bush assembly		bague droite complète	
■	308178-4-00	1	gruppo biella principale	main con-rod assembly		groupe bielle principale	
◆	310353-4-00	1	gruppo biella con eccentrico e perno	con-rod with eccentric and pin assembly		groupe bielle avec excentrique et pivot	
1	308254-3-00	1	biella con eccentrico e viti	con-rod with eccentric and screws		bielle avec excentrique et vis	
2	308310-0-00	1	perno a sfera	ball joint		pivot à sphere	
3	308802-0-00	2	vite per biella	screw for con-rod		vis pour bielle	
4	308855-0-00	1	vite	screw		vis	
5	308174-3-00	1	biella principale completa	main con-rod assembly		bielle principale complète	
6	741056-0-00	2	vite	screw		vis	
7	302272-0-10	1	settore	sector		secteur	
8	704869-0-00	1	rondella	washer		rondelle	
9	745815-2-00	2	vite	screw		vis	
10	308084-2-00	1	anello di registro con viti	adjustment ring with screws		bague de réglage avec vis	
11	746408-2-00	1	dado	nut		écrou	
12	705013-0-00	1	rondella	washer		rondelle	
13	745812-2-00	2	vite	screw		vis	
14	308159-2-01	1	manovella	crank		manivelle	
15	308166-0-00	1	perno	pin		pivot	
16	308161-0-00	2	vite	screw		vis	
17	308149-0-01	2	rondella	washer		rondelle	
18	308162-0-00	2	dado	nut		écrou	
19	308127-0-00	1	guarnizione	gasket		garniture	
20	308012-2-01	1	bussola	bush		bague	
21	700596-0-00	1	anello di tenuta	retainer ring		bague d'étanchéité	
22	742222-2-00	3	vite	screw		vis	

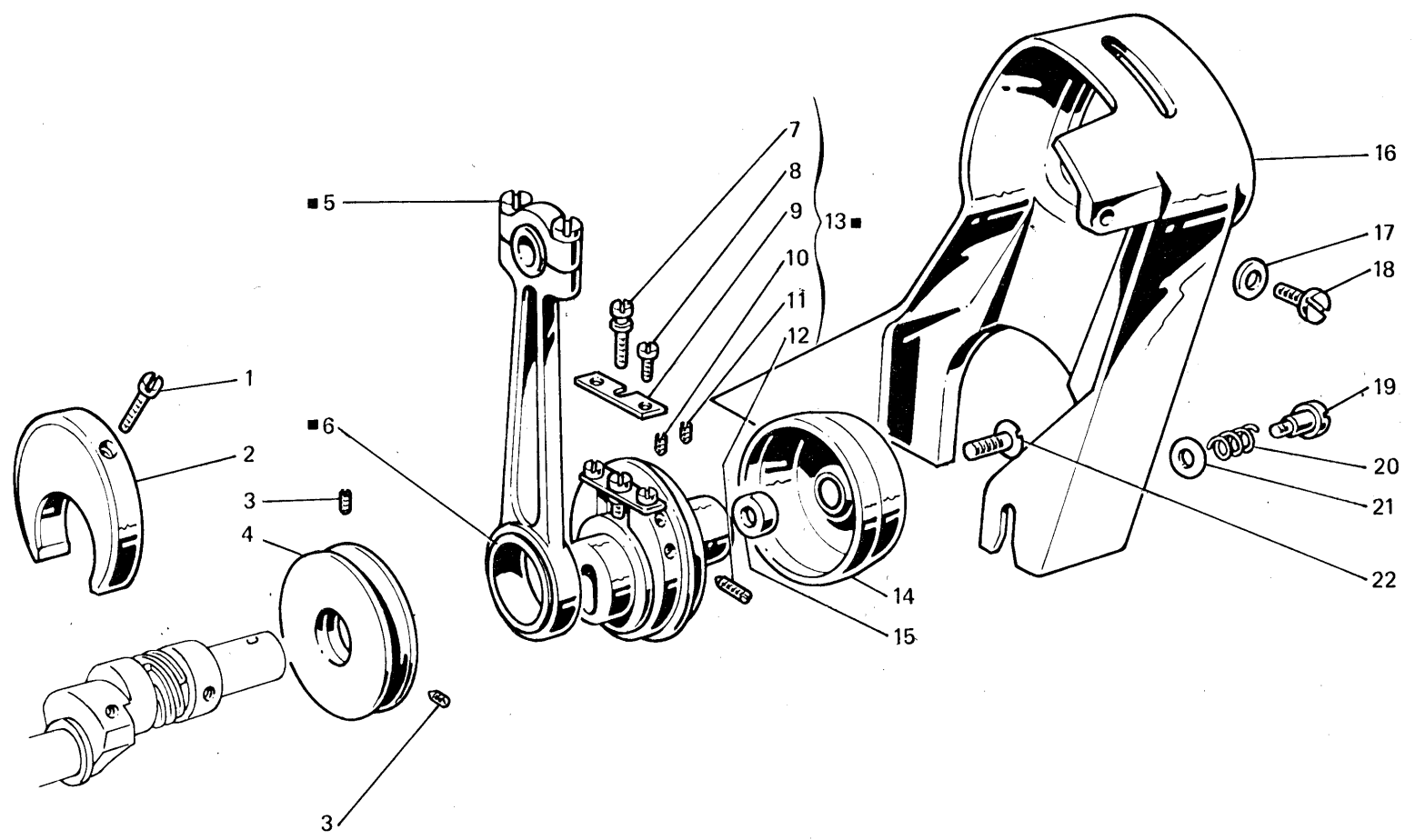
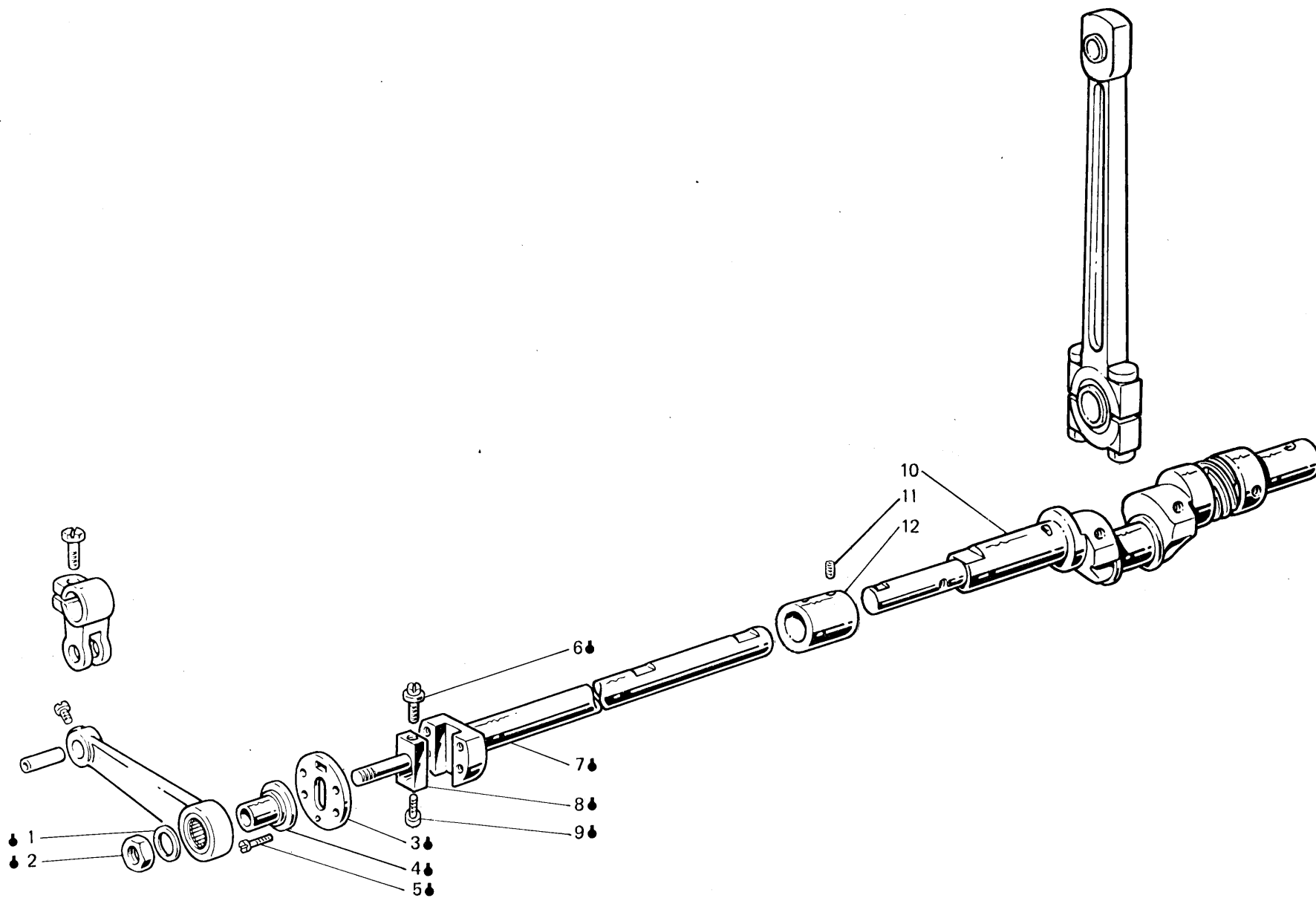

Fig. N. Abb. N.	Part. N. Piec. N. Bestell N. Pieza N.	Qt. Anzahl	DESCRIZIONE	DESCRIPTION	DESCRIPTION	BENENNUNG	DESCRIPCION
■	304481-4-00	1	biella con eccentrico regol.	con-rod with eccentric			
1	741088-2-00	2	vite	screw	bielle avec excentrique		
2	304445-0-11	1	contrappeso destro	right conterweight	vis		
3	729044-2-00	2	vite	screw	contreppoids droit		
4	308301-0-00	1	volantino	handwheel	vis		
5	743482-2-00	2	vite	screw	volant		
6	304480-0-00	1	cuscinetto	pad	vis		
7	304412-0-10	1	vite di registro	adjustment screw	cussin		
8	741721-2-00	2	vite	screw	vis de réglage		
9	304413-0-10	1	piastrina	plate	vis		
10	304462-0-20	2	vite	screw	plaque		
11	745317-0-00	2	vite	screw	vis		
12	730061-2-00	2	vite	screw	vis		
13	304449-4-20	1	eccentrico regol.completo	eccentric assembly	vis		
14	200678-0-10	1	coperchio	cover	excentrique complet		
15	304476-0-11	1	distanziale	spacer	couvercle		
16	304406-0-11	1	carter protezione	protection cover	entretoise		
17	704409-0-00	1	rondella	washer	carter protection		
18	721475-2-00	1	vite	screw	rondelle		
19	302349-0-10	2	vite per scodellino	screw for cup	vis		
20	302150-0-10	2	molla per scodellino	spring for cup	vis pour cuvette		
21	302151-0-10	2	scodellino	cup	ressort pour cuvette		
22	724908-2-00	1	vite	screw	cuvette		
					vis		



301:75-  
02

Fig. N. Abb. N.	Part. N. Piece N. Bestell N. Pieza N.	Ot. Anzahl	DESCRIZIONE	DESCRIPTION	DESCRIPTION	BENENNUNG	DESCRIPCION
—	309712-4-02	1	albero inferiore completo	lower shaft assembly	arbre inférieur complet		
●	308362-4-01	1	semialbero infer.completo	lower half-shaft assembly	semi-arbre inférieur complet		
1	704814-0-00	1	rondella	washer	rondelle		
2	746612-2-00	1	dado	nut	écrou		
3	308774-2-00	1	piastra disco	disc plate	plaque		
4	303458-0-12	1	bussola	bush	bague		
5	724441-0-00	4	vite	screw	vis		
6	308281-0-00	1	vite di registro	adjustment screw	vis de réglage		
7	308385-2-01	1	semialbero inf. sinistro	left lower half-shaft	semi-arbre inférieur gauche		
8	308278-0-01	1	perno	pin	pivot		
9	308780-2-00	1	vite di registro	adjustment screw	vis de réglage		
10	308715-3-02	1	semialbero inferiore destro	right lower half-shaft	semi-arbre inférieur droite		
11	745827-2-00	4	vite per manicotto	screw	vis		
12	308015-0-00	1	manicotto	coupling	manchon		



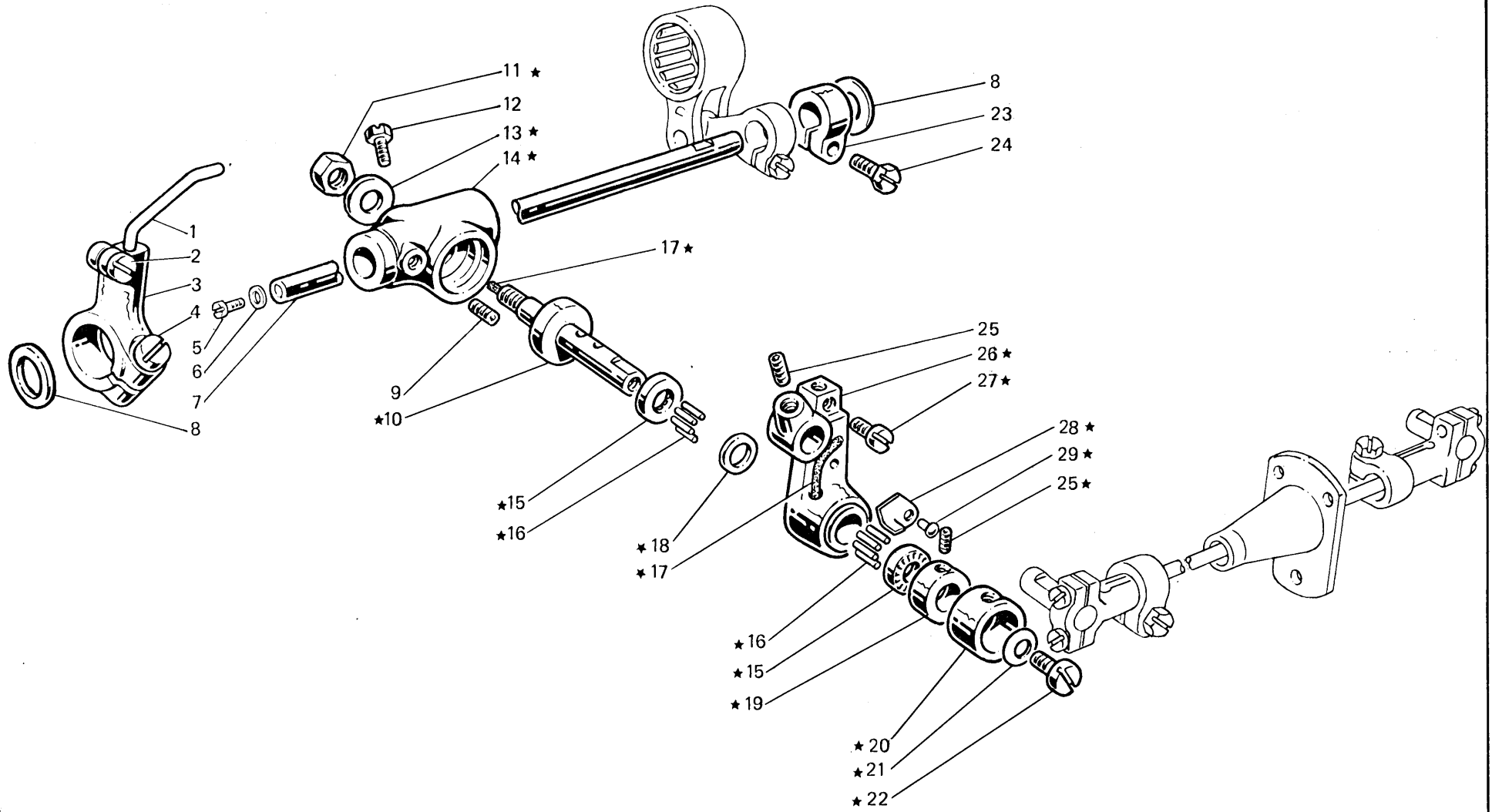

Fig. N. Abb. N.	Part. N. Piec. N. Bestell N. Pieza N.	Qt. Anzahl	DESCRIZIONE	DESCRIPTION	DESCRIPTION	BENENNUNG	DESCRIPCION
★	308261-4-00	1	gruppo porta crochet	looper holder assembly	groupe porte-crochet		
1	308142-0-00	1	spingi asola	front needle guard	pare-boucle		
2	741724-0-00	1	vite	screw	vis		
3	308050-2-00	1	porta spingi asola con viti	needle guard support with screws	porte pare-boucle avec vis		
4	721485-2-00	1	vite	screw	vis		
5	742214-2-00	1	vite	screw	vis		
6	705734-0-00	1	guarnizione	gasket	garniture		
7	308292-4-00	1	contralb.crochet infer.compl.	lower looper countershaft ass.	axe crochet inférieur complet		
8	704846-0-00	2	rondella	washer	rondelle		
9	730033-2-00	1	vite	screw	vis		
10	308271-0-01	1	perno	pin	pivot		
11	202474-0-10	1	dado	nut	écrou		
12	740226-0-00	1	vite per supporto	screw for support	vis pour support		
13	704226-2-00	1	rondella	washer	rondelle		
14	308140-0-00	1	supporto del porta crochet	support for looper holder	support du porte crochet		
15	303539-0-00	2	reggispinta	thrust bearing	butée		
16	302276-0-10	40	rullino	roller	rouleau		
17	778827-0-00	2	stoppino	wick	mèche		
18	703810-0-00	1	distanziale	spacer	entretoise		
19	302052-2-21	1	ghiera con viti	ring with screws	collier avec vis		
20	303538-0-00	1	cappellotto di protezione	protection cap	capouchon de protection		
21	702403-0-00	1	molla a tazza	cup spring	ressort à tasse		
22	742423-0-00	1	vite	screw	vis		
23	300469-2-11	1	fascetta	clamp	bride		
24	300482-0-10	1	vite	screw	vis		
25	745815-2-00	3	vite	screw	vis		
26	308266-2-01	1	porta crochet inferiore	lower looper holder	porte crochet inférieur		
27	303503-0-10	1	vite fissa crochet	looper fixing screw	vis blocage crochet		
28	308272-0-00	1	piastrina	sheet	plaquette		
29	308273-0-00	1	rivetto	rivet	rivet		

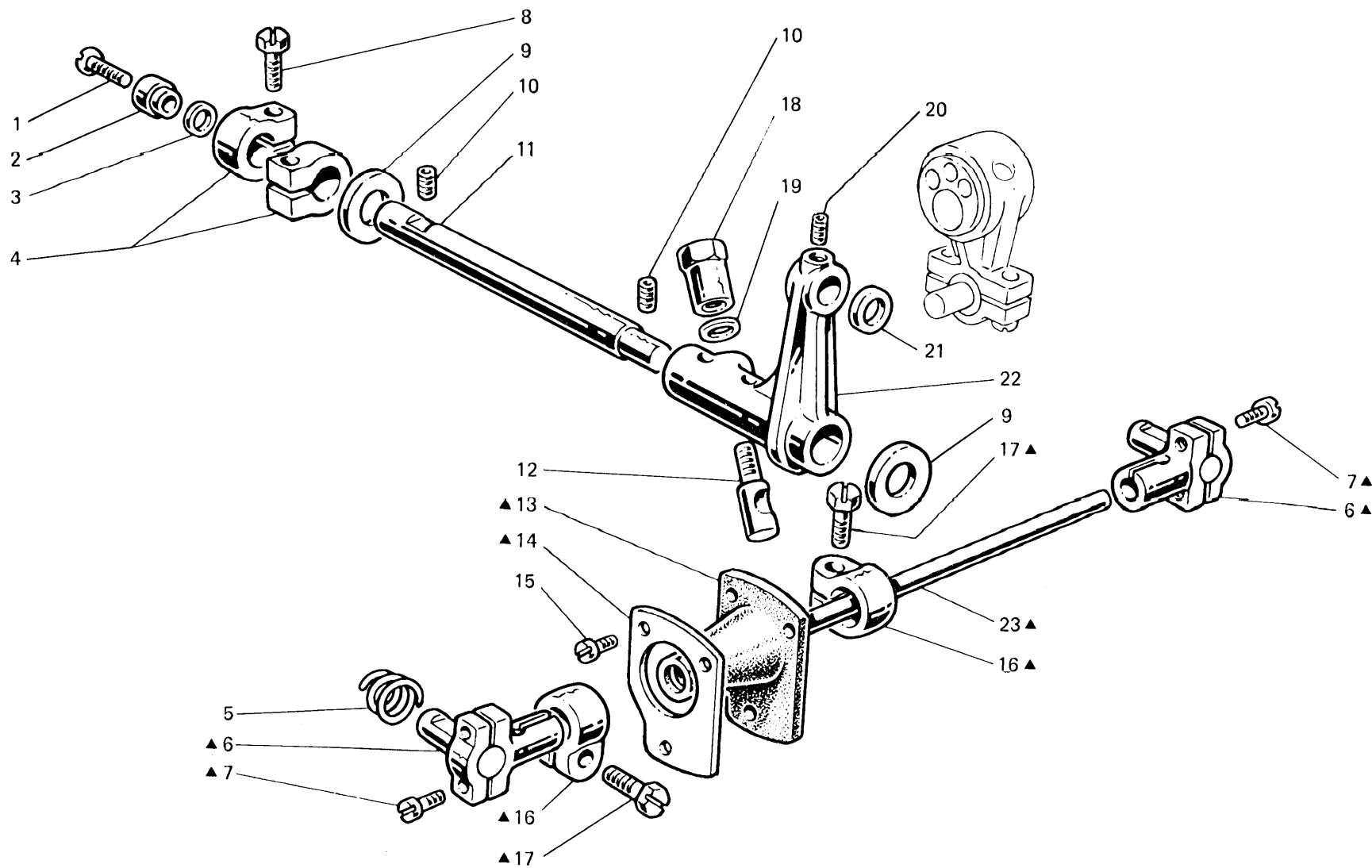

Fig. N. Abb. N.	Part. N. Piece N. Bestell N. Pieza N.	Qt. Anzahl	DESCRIZIONE	DESCRIPTION	DESCRIPTION	BENENNUNG	DESCRIPCION
▲	308332-4-00	1	gruppo comando crochet inf.	lower looper control assembly	groupe com. crochet inférieur		
1	744676-2-00	1	vite	screw	vis		
2	308047-0-00	1	scodellino	cup	cuvette		
3	701009-0-00	1	anello di tenuta	oil ring	bague d'étanchéité		
4	308046-2-01	2	fascetta	clamp	bride		
5	302289-0-10	1	molla	spring	ressort		
6	308325-3-00	2	testa di biella con viti	con-rod big end with screws	tête de bielle avec vis		
7	744040-2-00	4	vite	screw	vis		
8	300482-0-10	2	vite	screw	vis		
9	704849-0-00	2	rondella	washer	rondelle		
10	729434-2-00	2	vite fissa perno	screw	vis		
11	308044-0-00	1	perno per supporto	pin	pivot		
12	300352-0-10	1	spina filettata	pin	goupille		
13	308330-3-00	1	manicotto para olio	oil protection	manchon pare-huile		
14	308327-0-00	1	mascherina per manicotto	flange	flasque		
15	741675-2-00	2	vite	screw	vis		
16	308326-2-01	2	fascetta per biella con vite	clamp with screw	bride avec vis		
17	305194-0-00	2	vite	screw	vis		
18	300351-0-11	1	dado	nut	écrou		
19	704309-4-00	1	rondella	washer	rondelle		
20	745815-2-00	1	vite	screw	vis		
21	705834-0-00	1	rondella in fibra	washer	rondelle		
22	308045-0-01	1	supporto oscillante	support	support		
23	308333-0-01	1	tirante per biella	tie-rod	tirant pour bielle		

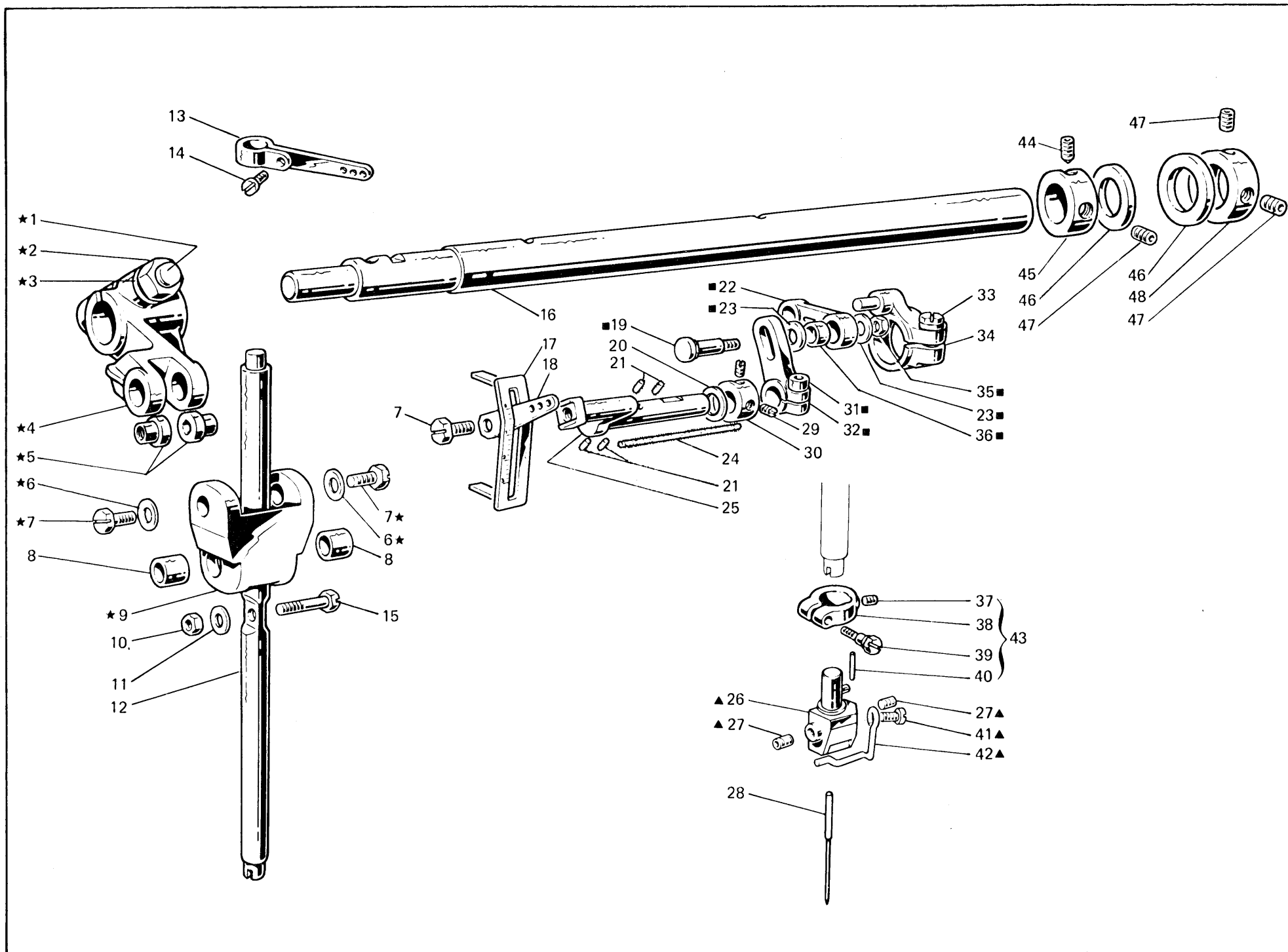

Fig. N. Abb. N.	Part. N. Piece N. Bestell N. Pieza N.	Qt. Anzahl	DESCRIZIONE	DESCRIPTION	DESCRIPTION	BENENNUNG	DESCRIPCION
★	308006-4-00	1	gruppo manov.giunto barra ago	crank and joint assembly			
▲	309803-4-00	1	morsetto porta aghi completo	needles clamp assembly	groupe maniv.joint barre-aiguille		
■	308244-4-00	1	gruppo sett.tendit.articolato	sector assembly	porte-aiguille complet		
1	308855-0-00	1	perno a vite	threaded pin	groupe secteur		
2	746408-2-00	1	dado	nut	pivot à vis		
3	705013-0-00	1	rondella	washer	écrou		
4	308036-2-00	1	manovella completa	crank assembly	rondelle		
5	308037-0-00	2	perno superiore	upper pin	groupe bras manivelle		
6	704210-4-00	2	rondella	washer	pivot supérieur		
7	308039-0-01	3	vite	screw	rondelle		
8	308041-0-00	2	bussola inferiore	lower bush	vis		
9	308038-0-10	1	giunto barra ago	needle bar joint	bague inférieure		
10	302338-0-10	1	dado	nut	joint barre-aiguille		
11	703005-0-00	1	rondella	washer	écrou		
12	308220-0-00	1	barra ago	needle bar	rondelle		
13	308139-2-01	1	tendifilo superiore	upper thread take-up	barre aiguille		
14	742311-2-00	1	vite	screw	tendeur supérieur		
15	308042-0-00	1	perno per barra ago	pin for needle bar	vis		
16	308851-2-01	1	albero superiore	upper shaft	pivot pour barre-aiguille		
17	308005-0-00	1	targhetta	plate	arbre supérieur		
18	308239-0-00	1	tendifilo inferiore	lower thread guide	plaque		
19	308235-0-00	1	perno	pin	tendeur du fil inférieur		
20	704828-0-00	1	rondella	washer	pivot		
21	778203-0-00	4	stoppino	wick	rondelle		
22	206583-0-00	1	biellino	con-rod	mèche		
23	705208-0-00	2	rondella	washer	petite bielle		
24	778407-0-00	1	stoppino	wick	rondelle		
25	308238-4-00	1	braccio con stoppini	arm with wicks	mèche		
26	309750-2-00	1	morsetto porta aghi	needles clamp	arbre avec mèches		
27	745810-2-00	2	vite	screw	porte-aiguilles		
28	766000-6-80	2	ago sist.Rim 63 fin.80	needle syst.Rim 63 size 80	vis		
29	745812-2-00	2	vite	screw	aiguille syst.Rim 63 jauge 80		
30	303899-0-10	1	anello	ring	vis		
31	722422-2-00	1	vite	screw	anneau		
32	308234-2-00	1	settore con vite	sector with screw	vis		
33	744334-2-00	1	vite	screw	secteur avec vis		
34	308236-2-01	1	braccio con vite	arm with screw	vis		
35	746008-0-00	1	dado	nut	bras avec vis		
36	202032-0-11	1	bussolina	bush	écrou		
37	745001-0-00	1	vite	screw	bague		
38	302591-0-10	1	fascetta per barra ago	clamp for needle bar	vis		
39	302352-0-10	1	vite	screw	bride pour barre-aiguille		
40	302292-0-10	1	spinetta	pin	vis		
41	741611-2-00	1	vite	screw	pivot		
42	309771-0-00	1	passafilo	thread guide	vis		
43	302590-4-10	1	fascetta completa	clamp assembly	bride complète		
44	730033-2-00	1	vite	screw	vis		
45	309831-2-00	1	anello di registro con viti	adjustment ting with screws	bague de réglage avec cis		

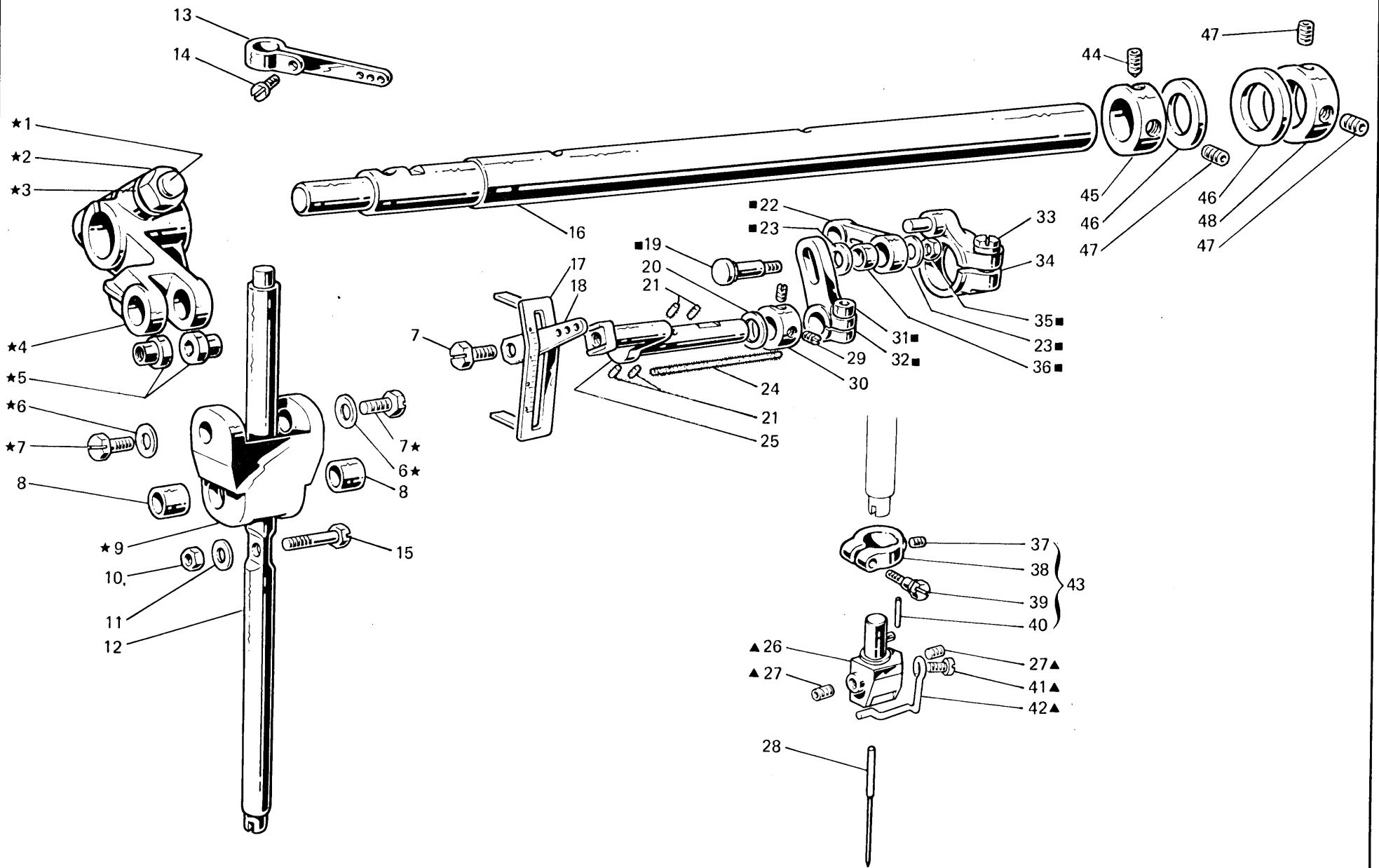

Fig. N. Abb. N.	Part. N. Bestell N. Piece N. Pieza N.	Qt. Anzahl	DESCRIZIONE	DESCRIPTION	DESCRIPTION	BENENNUNG	DESCRIPCION
46	704869-0-00	2	rondella	washer	rondelle		
47	729013-2-00	3	vite	screw	vis		
48	309830-2-00	1	anello di registro con viti	adjustment ring with screws	bague de réglage avec vis		



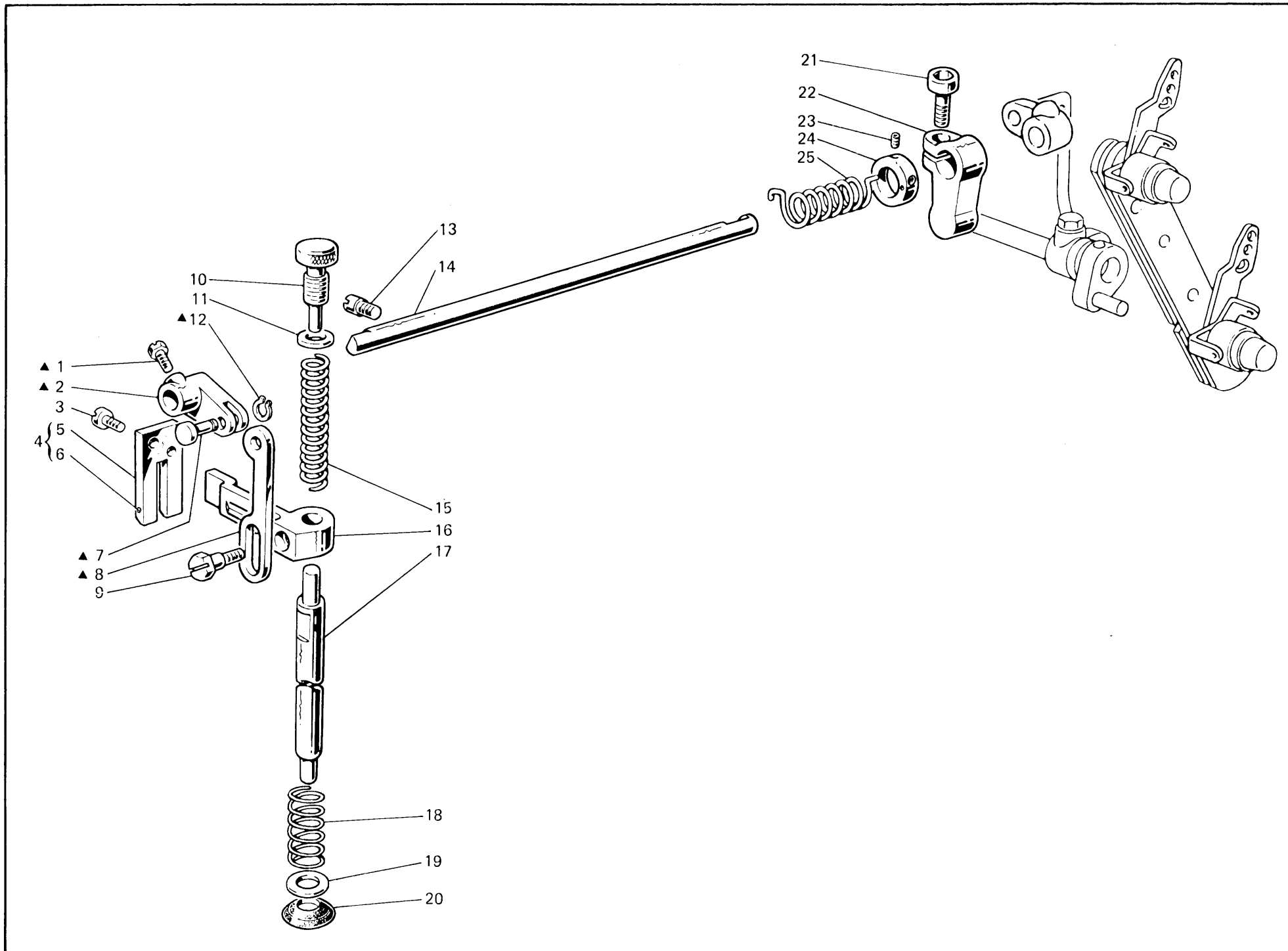

Fig. N. Abb. N.	Part. N. Piecce N. Bestell N. Pieza N.	Qt. Anzahl	DESCRIZIONE	DESCRIPTION	DESCRIPTION	BENENNUNG	DESCRIPCION
▲	308060-4-00	1	gruppo manov.tirante premist.	presser crank assembly	groupe maniv.tirant presseur		
1	740632-2-00	1	vite	screw	vis		
2	308059-0-00	1	manovella	crank	manivelle		
3	721494-2-00	2	vite fissa piastra	plate screw	vis blocage plaque		
4	308052-4-00	1	piastra guida barra compl.	plate assembly	plaque complète		
5	308056-0-01	1	piastra guida barra	plate	plaque		
6	707240-0-00	1	spina elastica	split pin	goupille réglable		
7	308058-0-00	1	spina	pin	goupille		
8	308057-0-00	1	tirante per alza piedino	presserfoot tie-rod	tirant soulèvement pied-presseur		
9	740444-2-00	1	vite fissa slitta	screw	vis		
10	302060-0-11	1	pomolo di regolazione	adjustment knob	pommeau de réglage		
11	302344-0-10	1	rondella	washer	rondelle		
12	700205-0-00	1	anello elastico	spring ring	anneau ressort		
13	308007-0-00	1	perno filettato	threaded pin	pivot fileté		
14	302234-0-10	1	albero	shaft	arbre		
15	302059-0-10	1	molla premi piedino	spring	ressort		
16	308055-2-00	1	guida a forcella	forket guide	guide à fourchette		
17	308061-0-01	1	barra porta piedino	presserfoot bar	barre porte pied-presseur		
18	308148-0-00	1	molla	spring	ressort		
19	704236-2-00	1	rondella	washer	rondelle		
20	308054-0-01	1	paraolio	oil retainer	pare-huile		
21	744332-2-00	1	vite	screw	vis		
22	308412-2-02	1	fascetta di fermo con vite	clamp with screw	bride de fixation avec vis		
23	745827-2-00	2	vite	screw	vis		
24	304767-2-10	1	anello per molla	ring	bague		
25	308098-0-00	1	molla di torsione	spring	ressort de torsion		

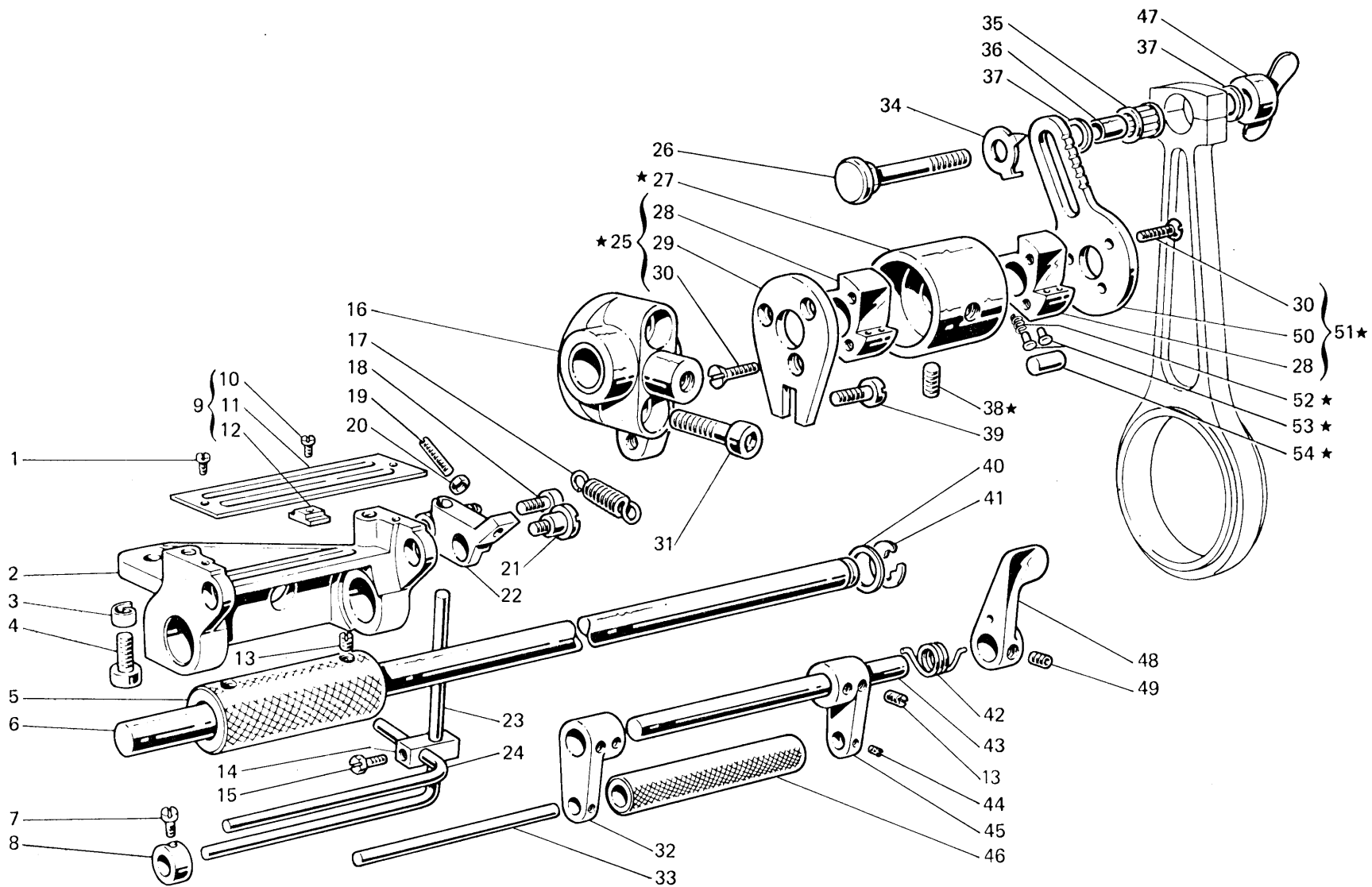

Fig. N. Abb. N.	Part. N. Bestell N. Piece N. Pieza N.	Qt. Anzahl	DESCRIZIONE	DESCRIPTION	DESCRIPTION	BENENNUNG	DESCRIPCION
★	304431-4-11	1	frizione completa	clutch assembly	friction complète		
1	721412-2-00	2	vite	screw	vis		
2	304467-4-11	1	supporto frizione con bussole e stoppini	clutch support with bushes and wicks	support friction avec bagues et mèches		
3	308147-0-00	2	nastro	strap	bande		
4	722433-2-00	2	vite	screw	vis		
5	304468-2-20	1	rullo con viti	roller	rouleau		
6	304469-0-11	1	albero	shaft	arbre		
7	742811-0-00	4	vite	screw	vis		
8	304458-0-10	4	anello	ring	anneau		
9	304473-4-10	1	piastrina completa	plate assembly	plaque complète		
10	741403-0-00	4	vite	screw	vis		
11	304472-0-10	1	piastrina	plate	plaque		
12	203949-0-10	4	cursore	slider	curseur		
13	727014-2-00	6	vite	screw	vis		
14	304460-0-10	1	blocchetto	block	bloc		
15	740220-2-00	2	vite	screw	vis		
16	304423-4-21	1	supporto con spina e fig.39	support with pin and fig.39	support avec pivot et fig.39		
17	304457-0-10	1	molla	spring	ressort		
18	722411-2-00	1	vite	screw	vis		
19	727082-0-00	1	vite	screw	vis		
20	746002-2-00	1	dado	nut	écrou		
21	304463-0-10	1	vite	screw	vis		
22	304453-2-10	1	attacco e spina	coupling and pin	raccord et goupille		
23	304456-0-11	1	asta	rod	tige		
24	304459-0-10	1	asta	rod	tige		
25	304432-4-10	1	settore con flangia destra	sector with right flange	secteur avec flasque droit		
26	304086-0-10	1	perno	pin	pivot		
27	304430-0-10	1	corpo frizione	clutch case	crops friction		
28	301523-0-10	2	settore	sector	secteur		
29	203928-0-10	1	flangia	flange	flasque		
30	724471-0-00	6	vite	screw	vis		
31	722483-2-00	2	vite	screw	vis		
32	304438-0-10	1	spalla sinistra	left support	support gauche		
33	304474-0-10	1	perno	pin	pivot		
34	304073-0-10	1	indice	index	indice		
35	201358-0-10	1	gabbia a rulli	needles cage	cage à aiguilles		
36	304436-0-10	1	anello	ring	anneau		
37	704216-2-00	2	rondella	washer	rondelle		
38	729043-2-00	2	vite	screw	vis		
39	744553-0-00	1	vite	screw	vis		
40	704841-0-00	1	rondella	washer	rondelle		
41	700212-0-00	1	anello elastico	spring ring	anneau ressort		
42	304441-0-10	1	molla	spring	ressort		
43	304475-0-10	1	asta	rod	tige		
44	745002-0-00	2	vite	screw	vis		
45	304437-0-10	1	spalla destra	right support	support droit		
46	304471-2-10	1	rullo	roller	rouleau		
47	200413-2-10	1	pomolo con alette	knob with flyer	pommeau avec ailette		

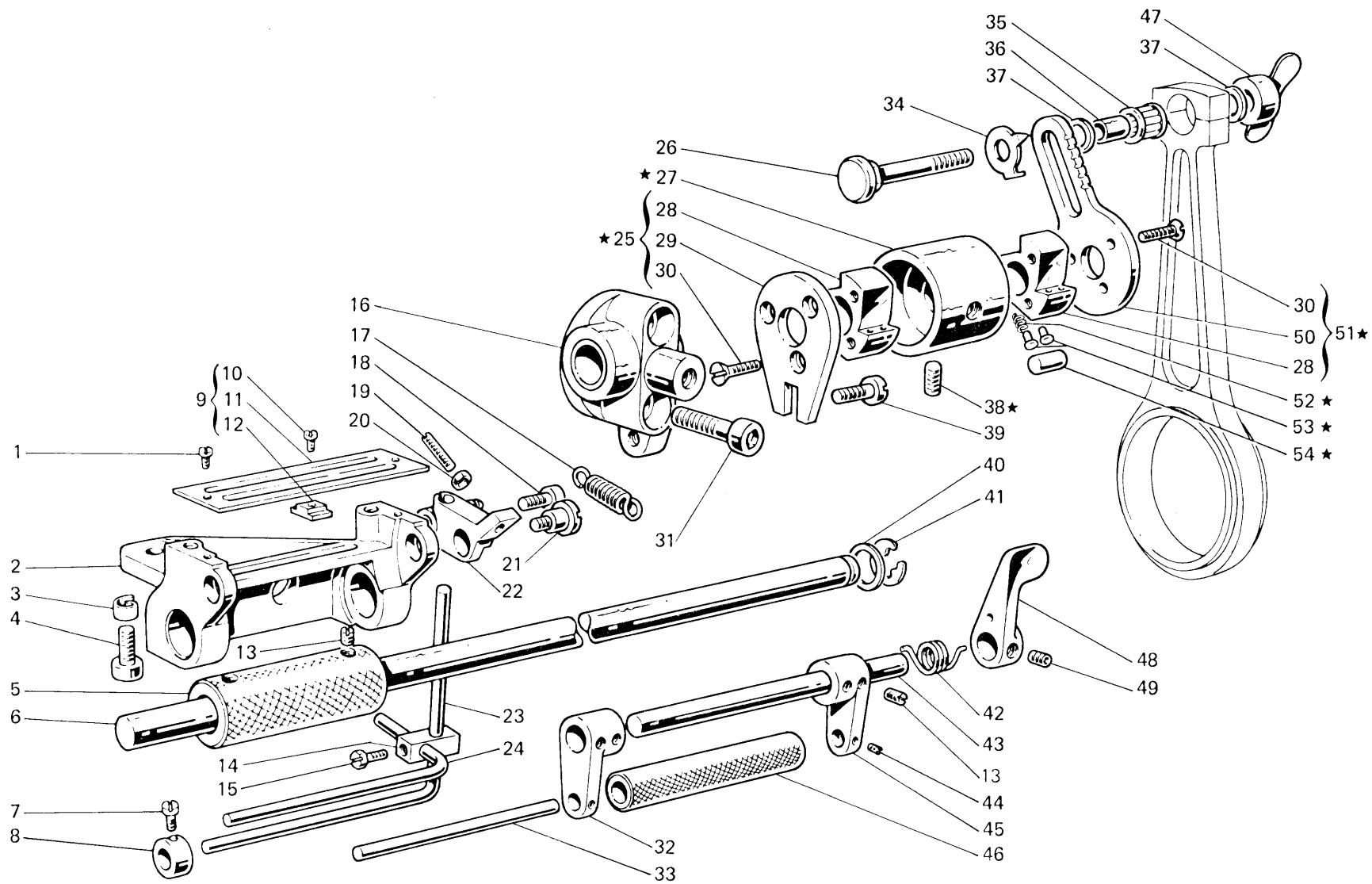

Fig. N. Abb. N.	Part. N. Piecce N. Bestell N. Pieza N.	Qt. Anzahl	DESCRIZIONE	DESCRIPTION	DESCRIPTION	BENENNUNG	DESCRIPCION
48	304424-0-10	1	leva	lever	levier		
49	745812-2-00	2	vite	screw	vis		
50	304084-0-10	1	flangia	flange	flasque		
51	304085-4-10	1	settore con flangia sinistra	sector with left flange	secteur avec flasque gauche		
52	304477-0-01	12	molla	spring	ressort		
53	304478-0-00	12	pernetto	pin	pivot		
54	301527-0-10	6	rullino	roller	rouleau		

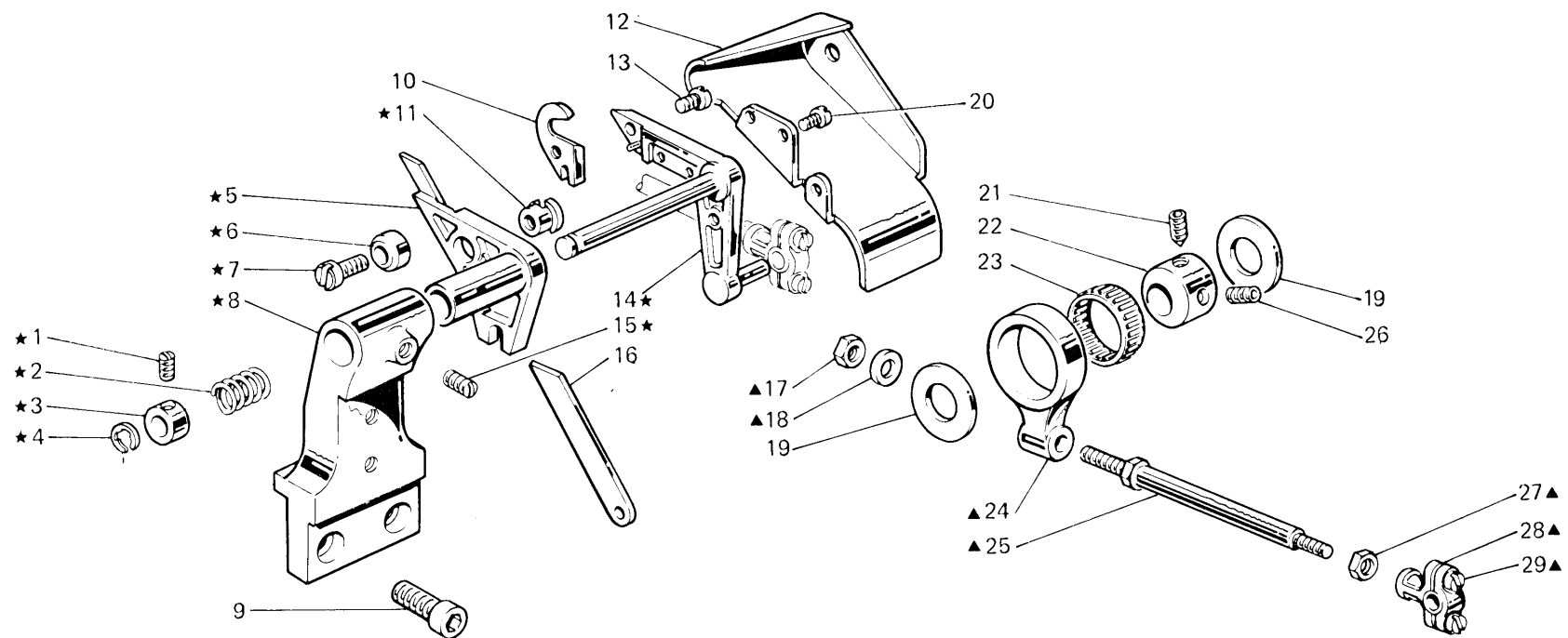

Fig. N. Abb. N.	Part. N. Piece N. Bestell N. Pieza N.	Qt. Anzahl	DESCRIZIONE	DESCRIPTION	DESCRIPTION	BENENNUNG	DESCRIPCION
★	309380-4-01	1	porta coltello completo	knife holder assembly	porte-couteau complet		
▲	302813-4-10	1	biella comando coltelli compl.	knives con-rod assembly	bielle com.couteaux compl.		
1	745114-0-00	2	vite	screw	vis		
2	302803-0-10	1	molla	spring	ressort		
3	302859-0-10	1	anello	ring	anneau		
4	700210-0-00	1	anello elastico	spring ring	anneau ressort		
5	302804-2-10	1	porta coltello inferiore	lower knife holding	porte couteaux inférieur		
6	302864-0-10	1	scodellino	cup	cuvette		
7	721475-2-00	1	vite	screw	vis		
8	309373-2-00	1	supporto	support	support		
9	722454-2-00	2	vite	screw	vis		
10	302807-0-10	1	coltello superiore	upper knife	couteau supérieur		
11	302806-0-10	1	anello	ring	anneau		
12	302840-0-10	1	carterino	cover	carter		
13	741642-2-00	1	vite	screw	vis		
14	302801-3-11	1	porta coltello superiore	upper knife holding	porte couteau supérieur		
15	727056-0-00	1	vite	screw	vis		
16	302808-0-10	1	coltello inferiore	lower knife	couteau inférieur		
17	746204-2-00	1	dado	nut	écrou		
18	703208-0-00	1	rondella elastica	spring washer	rondella élastique		
19	703825-0-00	2	rondella	washer	rondelle		
20	721412-2-00	3	vite	screw	vis		
21	730023-2-00	1	vite	screw	vis		
22	308762-2-00	1	eccentrico compl.con viti	eccentric ass.with screws	excentrique complet avec cis		
23	302857-0-10	1	gabbia a rullini	needles cage	cage à aiguilles		
24	302812-0-10	1	giunto	joint	joint		
25	302846-0-10	1	tirante	tie-rod	tirant		
26	729013-2-00	1	vite	screw	vis		
27	302708-0-01	1	dado	nut	écrou		
28	302844-3-10	1	testa di biella	con-rod big end	tête de bielle		
29	743243-2-00	2	vite	screw	vis		
			SOLO A RICHIESTA	ONLY ON REQUEST	SEULEMENT SUR DEMANDE		
10	302865-0-10	1	coltello superiore	upper knife	couteau supérieur		
	305671-2-00	1	coltello superiore	upper knife	couteau supérieur		
	302866-0-10	1	coltello superiore	upper knife	couteau supérieur		
12	302869-0-10	1	carterino	cover	carter		
16	305670-2-00	1	coltello inferiore	lower knife	couteau inférieur		



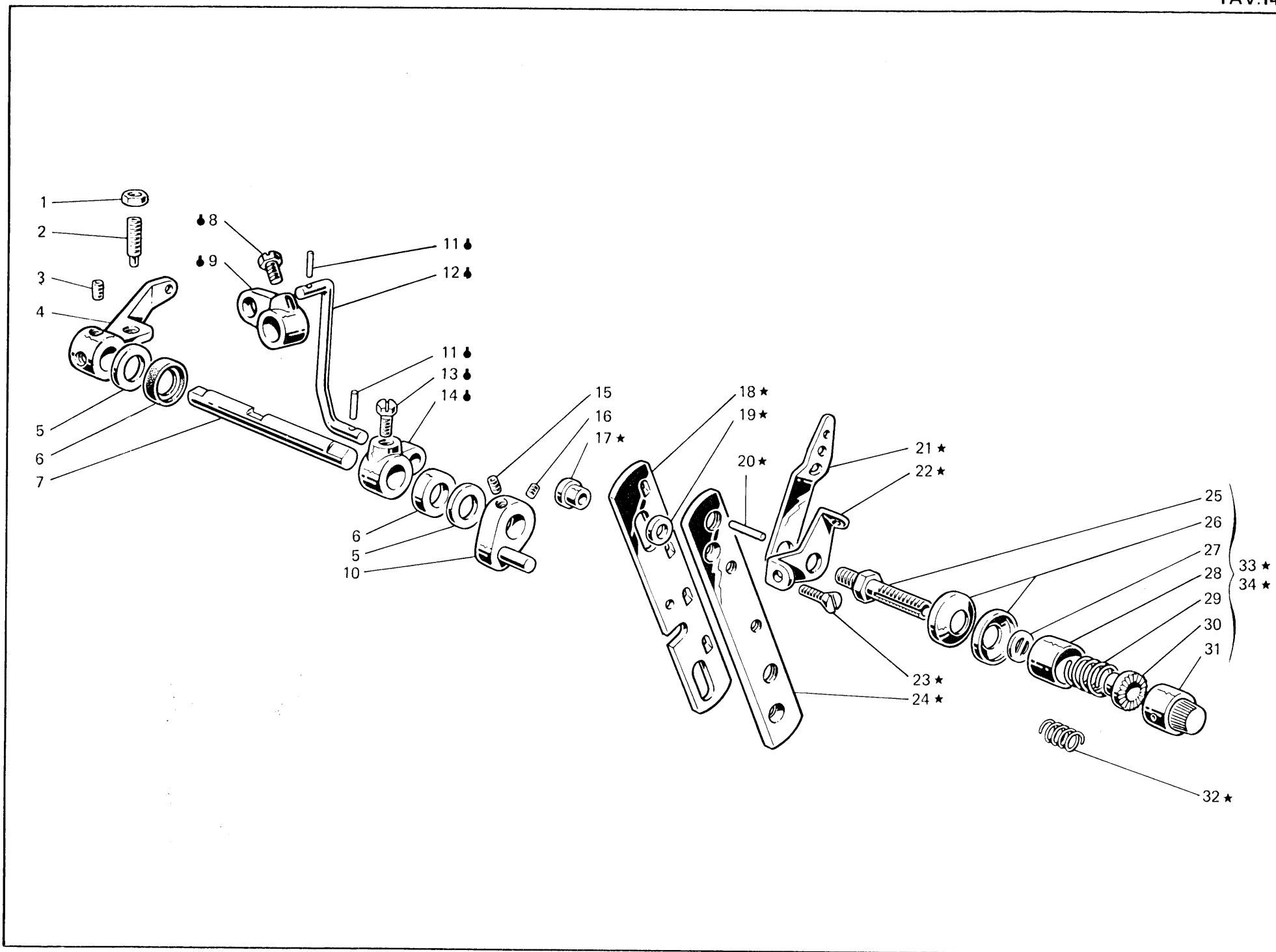

Fig. N. Abb. N.	Part. N. Piec. N. Bestell N. Pieza N.	Qt. Anzahl	DESCRIZIONE	DESCRIPTION	DESCRIPTION	BENENNUNG	DESCRIPCION
★	308532-4-00	1	gruppo tensioni	tension assembly	groupe tension		
●	308320-4-00	1	tirante con leva	tie-rod with lever	tirant avec levier		
1	746204-0-00	1	dado	nut	écrou		
2	729884-2-00	1	vite	screw	vis		
3	729034-2-00	2	vite per leva	screw for lever	vis pour levier		
4	308062-2-00	1	leva comando alza piedino	presserfoot control lever	levier soulèv. pied presseur		
5	704240-2-00	2	rondella	washer	rondelle		
6	304763-0-10	2	anello di tenuta	retainer ring	bague d'étanchéité		
7	308996-0-01	1	albero comando alza piedino	shaft	arbre		
8	740632-2-00	1	vite	screw	vis		
9	302232-0-10	1	leva superiore	upper lever	levier supérieur		
10	308496-2-00	1	leva sblocca tensione	lever	levier		
11	707241-0-00	2	spina elastica	split pin	goupille réglable		
12	308321-0-00	1	tirante	tie-rod	tirant		
13	740034-2-00	1	vite per leva	screw for lever	vis pour levier		
14	302238-0-10	1	leva per tirante	tie-rod lever	levier pour tirant		
15	745126-2-00	1	vite	screw	vis		
16	727834-2-00	1	vite	screw	vis		
17	308513-0-00	2	distanziale	spacer	entretoise		
18	308502-0-00	1	slitta per tensione	slide for tension	glissière pour tension		
19	701007-0-00	2	anello	ring	anneau		
20	308506-0-00	3	pernetto	pin	pivot		
21	308501-0-01	3	passafilo	thread guide	passe-fil		
22	308503-0-01	3	guidafilo	thread guide	guide-fil		
23	744587-2-00	2	vite	screw	vis		
24	308504-0-00	1	supporto	support	support		
25	308505-0-00	3	perno a vite	threaded pin	pivot à vis		
26	300218-0-10	6	disco tensione	tension disc	disque tension		
27	308507-0-00	3	rondella	washer	rondelle		
28	202556-0-00	3	scodellino	cup	cuvette		
29	200710-0-10	2	molla	spring	ressort		
30	202229-0-10	3	bussola superiore	upper bush	bague supérieure		
31	202558-2-00	3	pomolo	knob	pommeau		
32	200714-0-10	1	molla	spring	ressort		
33	308518-4-00	2	tensione sup.con molla fig.29	upper tension with spring fig.29	tension sup.avec ressort fig.29		
34	308521-4-00	1	tensione inf.con molla fig.32	lower tension with spring fig.32	tension inf.avec ressort fig.32		

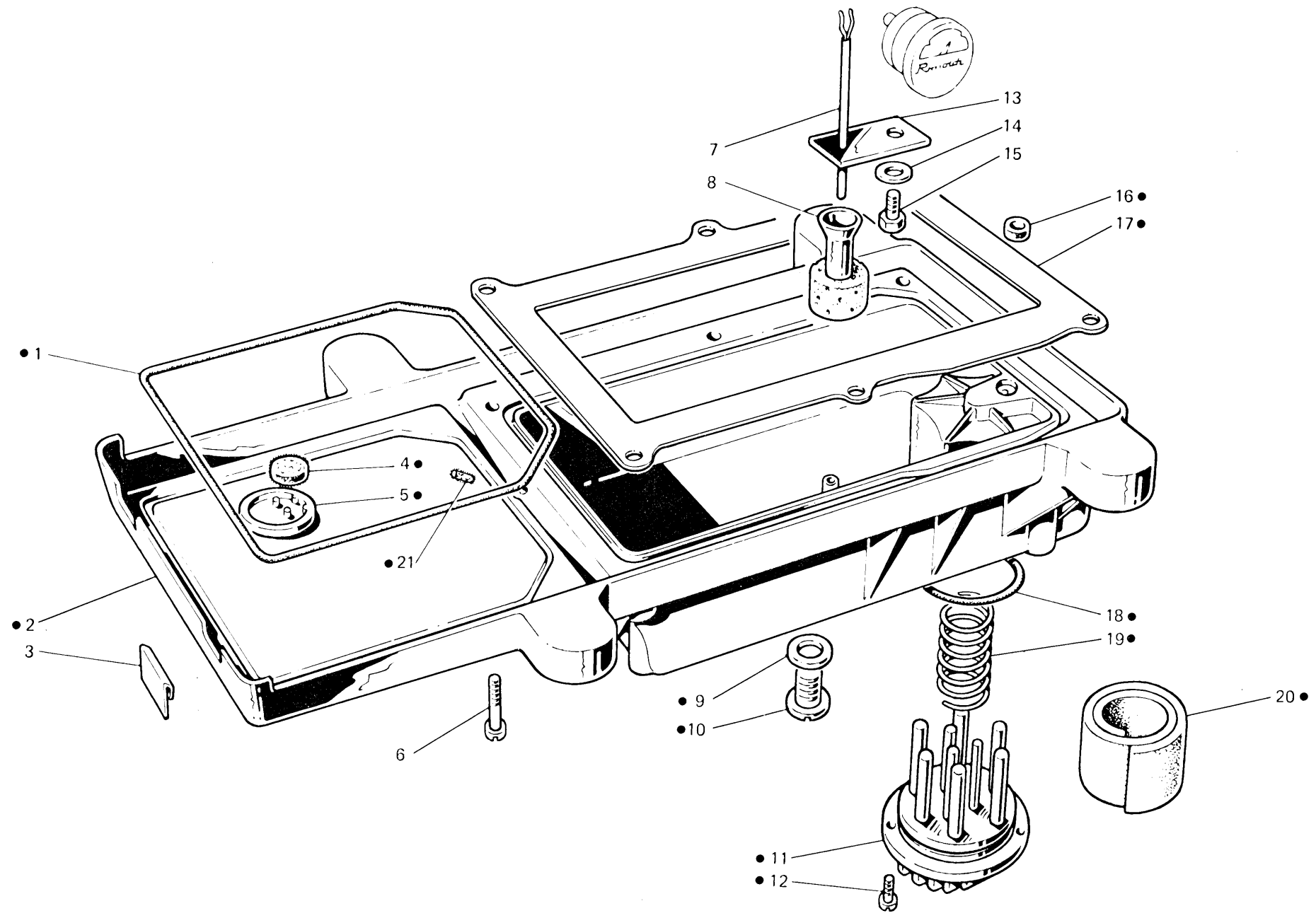

Fig. N. Abb. N.	Part. N. Bestell N. Piece N. Pieza N.	Qt. Anzahl	DESCRIZIONE	DESCRIPTION	DESCRIPTION	BENENNUNG	DESCRIPCION
●	308589-4-03	1	bacinella olio completa	oil sump assembly	reservoir huile complet		
1	308125-0-00	1	guarnizione	gasket	garniture		
2	308577-2-10	1	bacinella	sump	reservoir		
3	308002-0-00	2	piastrina per bacinella	sheet for sump	plaquette pour reservoir		
4	308151-0-00	1	filtro	filter	filtre		
5	308150-0-10	1	scodellino recupero olio	cup	cuvette		
6	722453-2-00	6	vite per fiss.bacinella	sump fixing screw	vis blocage reservoir		
7	308231-2-01	1	astina livello olio	stick	jauge niveau huile		
8	308228-2-00	1	galleggiante	float	flotteur		
9	705977-0-00	1	rondella	washer	rondelle		
10	206564-0-00	1	tappo	plug	bouchon		
11	206560-0-10	1	coperchio	cover	couvercle		
12	721464-2-00	2	vite	screw	vis		
13	308226-0-02	1	guida astina	guide for stick	guide barre		
14	703003-0-00	1	rondella elastica	spring washer	rondelle élastique		
15	740240-0-00	1	vite	screw	vis		
16	308113-0-00	1	anello	oil ring	bague d'étanchéité		
17	311395-0-00	1	guarnizione	gasket	garniture		
18	701051-0-00	1	guarnizione	gasket	garniture		
19	206545-0-00	1	molla a spirale	spring	ressort		
20	206559-0-00	1	filtro	filter	filtre		
21	778461-0-00	1	stoppino	wick	mèche		

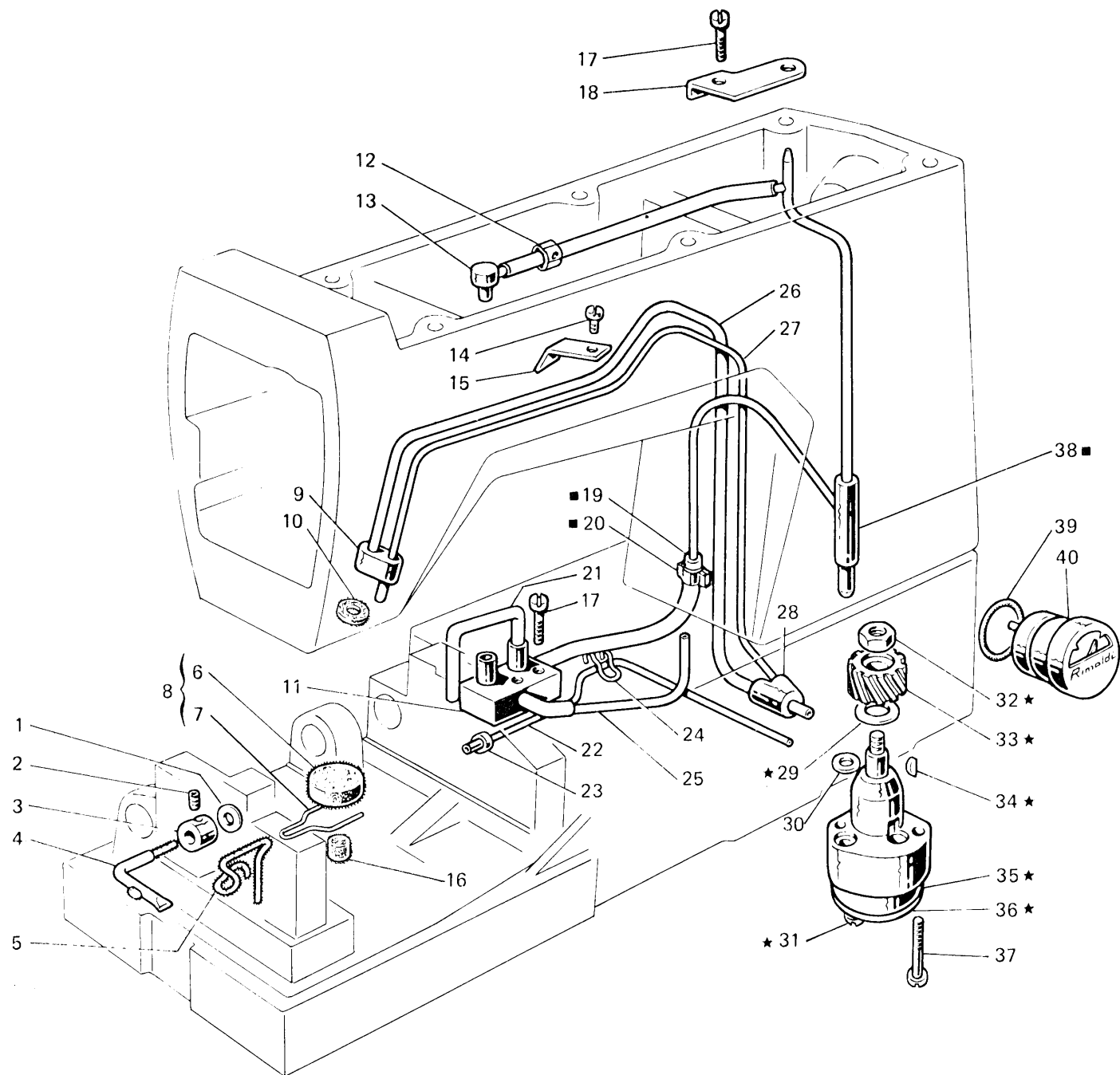

Fig. N. Abb. N.	Part. N. Piec. N. Bestell N. Pieza N.	Qt. Anzahl	DESCRIZIONE	DESCRIPTION	DESCRIPTION	BENENNUNG	DESCRIPCION
■	310500-4-00	1	raccordo mandata olio compl.	pipe connection assembly	raccord envoi huile compl.		
★	308105-4-01	1	pompa olio completa	oil pump assembly	pumpe huile complète		
1	300420-0-10	1	rondella	washer	rondelle		
2	730011-2-00	1	vite	screw	vis		
3	300419-0-10	1	raccordo	raccord	raccord		
4	308243-3-00	1	tubetto e stoppino	pipe and wick	tube et mèche		
5	778240-0-00	1	stoppino	wick	mèche		
6	308153-0-00	1	filtro	filter	filtre		
7	308154-0-00	1	molletta	spring	ressort		
8	308155-4-01	1	gruppo molletta con filtro	spring with filter assembly	groupe ressort avec filtre		
9	308123-0-00	1	raccordo superiore	upper pipe union	raccord supérieur		
10	308219-0-00	1	feltro	felt	feutre		
11	308114-2-01	1	distributore	distributor	distributeur		
12	308040-2-00	1	tubetto	pipe	tube		
13	308214-0-00	1	raccordo mandata olio	pipe union	raccord		
14	721424-2-00	1	vite	screw	vis		
15	308184-0-00	1	fascetta	clamp	bride		
16	308295-0-00	1	filtro	filter	filtre		
17	721514-0-00	3	vite	screw	vis		
18	308104-0-00	1	piastrina	plate	plaquette		
19	308207-0-00	1	tubetto	pipe	tube		
20	308043-0-00	1	fascetta	clamp	bride		
21	790307-0-00	1	tubetto	pipe	tube		
22	790325-0-00	1	tubetto	pipe	tube		
23	308212-0-00	1	bussolina olio	bush	bague		
24	308211-0-00	2	clip	clip	clip		
25	790315-0-00	1	tubetto	pipe	tube		
26	790342-0-00	1	tubetto recupero olio	pipe	tube		
27	790242-0-00	1	tubetto recupero olio	pipe	tube		
28	308185-0-00	1	raccordo inferiore	lower pipe union	raccord inférieur		
29	704813-0-00	1	rondella	washer	rondelle		
30	701004-0-00	1	anello di tenuta	oil ring	bague d'étanchéité		
31	741082-2-00	2	vite	screw	vis		
32	733507-0-00	1	dado	nut	écrou		
33	206555-0-01	1	ingranaggio	gear	engrenage		
34	206557-0-00	1	chiavetta	key	clavette		
35	308110-3-01	1	corpo pompa aspirante	suction pump body	corps pompe admission		
36	308111-0-00	1	coperchio pompa	pump cover	couvercle pompe		
37	741092-0-00	2	vite fissaggio pompa	pump fixing screw	vis fixation pompe		
38	308180-2-00	1	raccordo mandata olio	pipe union	raccord		
39	701032-0-00	1	anello di tenuta	oil ring	bague d'étanchéité		
40	206669-2-02	1	indicatore livello olio	oil level gauge	indicateur niveau huile		

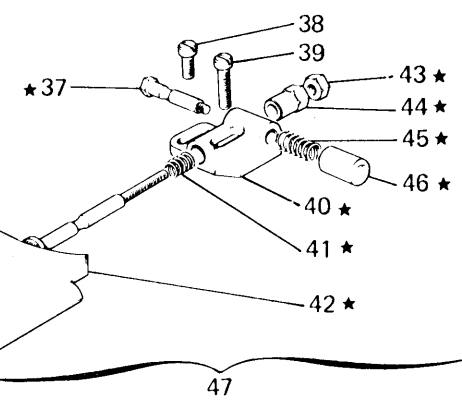
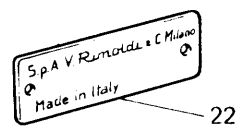
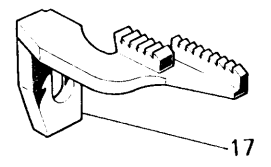
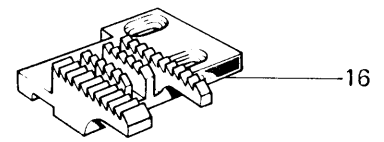
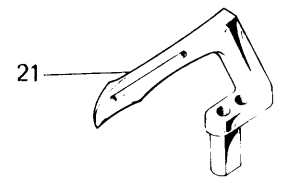
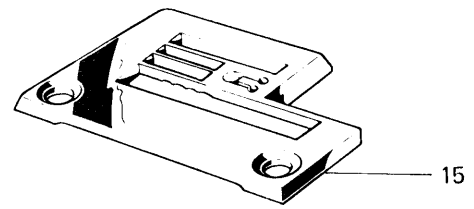
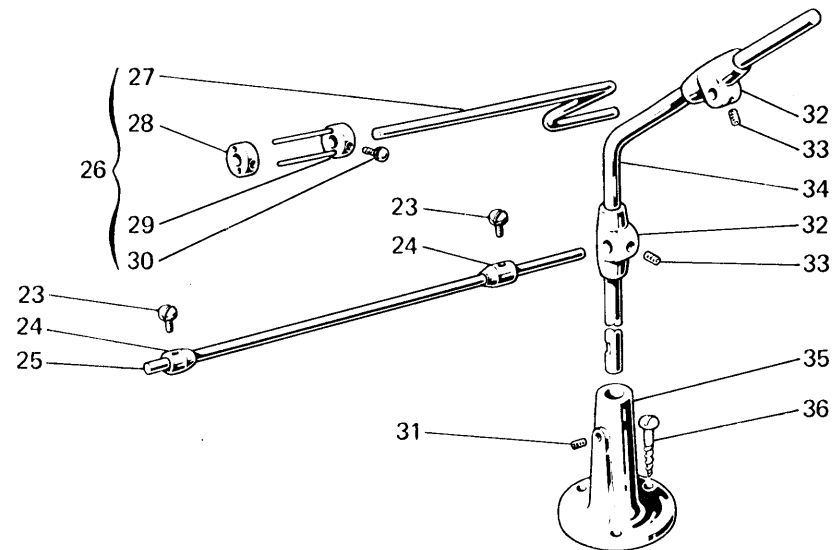
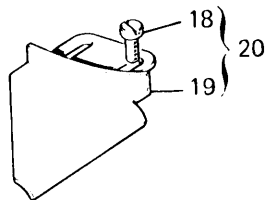
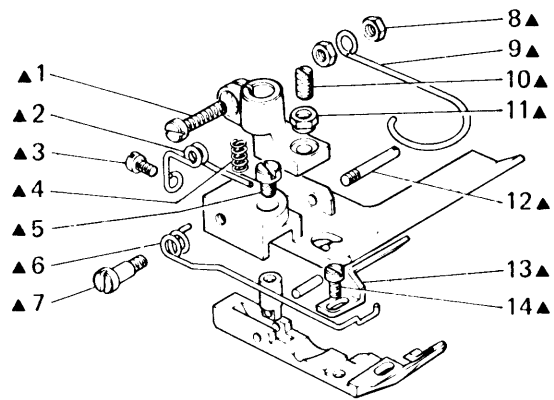

Fig. N. Abb. N.	Part. N. Bestell N. Pieze N. Pieza N.	Qt. Anzahl	DESCRIZIONE	DESCRIPTION	DESCRIPTION	BENENNUNG	DESCRIPCION
▲	306679-3-00	1	piedino completo	presserfoot assembly	pied-presseur complet		
●	990709-4-12	1	porta rotolo completo	roll carrier assembly	porte-rouleau complet		
1	741781-2-00	1	vite	screw	vis		
2	300119-0-11	1	molla	spring	ressort		
3	721411-2-00	1	vite	screw	vis		
4	303052-0-00	1	molla	spring	ressort		
5	741414-2-00	1	vite	screw	vis		
6	302821-0-10	1	molla	spring	ressort		
7	743134-2-00	1	vite	screw	vis		
8	733504-2-00	2	dado	nut	écrou		
9	990808-0-01	1	salvadita	protection	protection		
10	301596-0-11	1	vite	screw	vis		
11	301598-0-11	1	dado	nut	écrou		
12	300120-0-10	1	spina	pin	goupille		
13	302773-0-11	1	guida	guide	guide		
14	741413-2-00	1	vite	screw	vis		
15	302811-0-10	1	placca ago	needle plate	plaque aiguille		
16	302796-0-10	1	griffa principale	main feed dog	griffe principale		
17	302798-0-10	1	griffa differenziale	differential feed dog	griffe différentielle		
18	721434-2-00	2	vite	screw	vis		
19	302851-2-10	1	guida	guide	guide		
20	310040-4-00	1	guida con viti	guide with screws	guide avec vis		
21	302057-0-11	1	crochet inferiore	lower looper	crochet inférieur		
22	784364-0-20	1	targhetta classe testa	head class plate	plaque classe tête		
23	990596-0-10	2	pomolo	knob	pommeau		
24	990594-2-00	2	anello di registro con pomolo	adjustment ring with knob	anneau de réglage avec pommeau		
25	990593-0-11	1	spina	pin	goupille		
26	990705-4-11	1	passa nastro	strap guide	guide pour bande		
27	990704-0-11	1	spina	pin	goupille		
28	990708-0-10	1	morsetto	clamp	bride		
29	990707-2-10	1	morsetto con spine	clamp with pins	bride avec goupilles		
30	930096-0-10	2	pomolo	knob	pommeau		
31	729054-2-00	1	vite	screw	vis		
32	991153-2-00	2	supporto con viti	support with screws	support avec vis		
33	729024-2-00	4	vite	screw	vis		
34	990703-0-11	1	asta	rod	tige		
35	991114-2-00	1	basetta con vite	base with screw	base avec vis		
36	731107-2-00	3	vite da legno	screw	vis		
			SOLO A RICHIESTA	ONLY ON REQUEST	SEULEMENT SUR DEMANDE		
★	302765-4-10	1	guida regolabile	control guide	guide réglable		
37	302762-0-10	1	perno	pin	pivot		
38	721474-2-00	1	vite	screw	vis		
39	721494-2-00	1	vite	screw	vis		
40	302768-0-10	1	blocchetto	block	bloc		
41	302766-0-10	1	molla	spring	ressort		
42	302764-2-10	1	guida	guide	guide		
43	746021-2-00	1	dado	nut	écrou		
44	302769-0-10	1	pomolo	knob	pommeau		



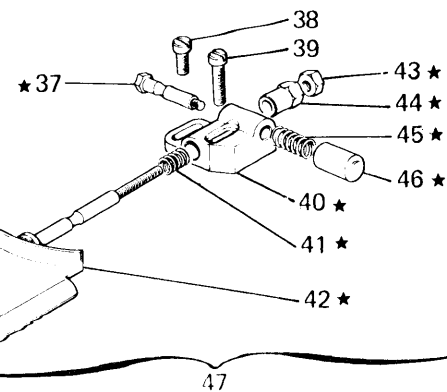
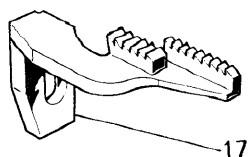
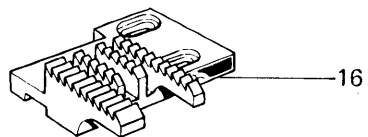
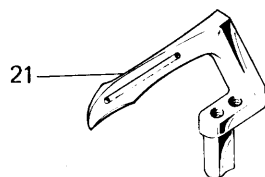
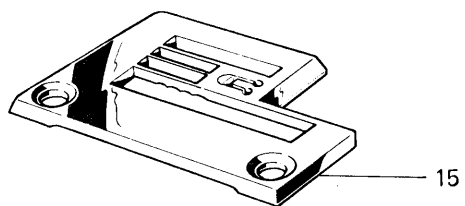
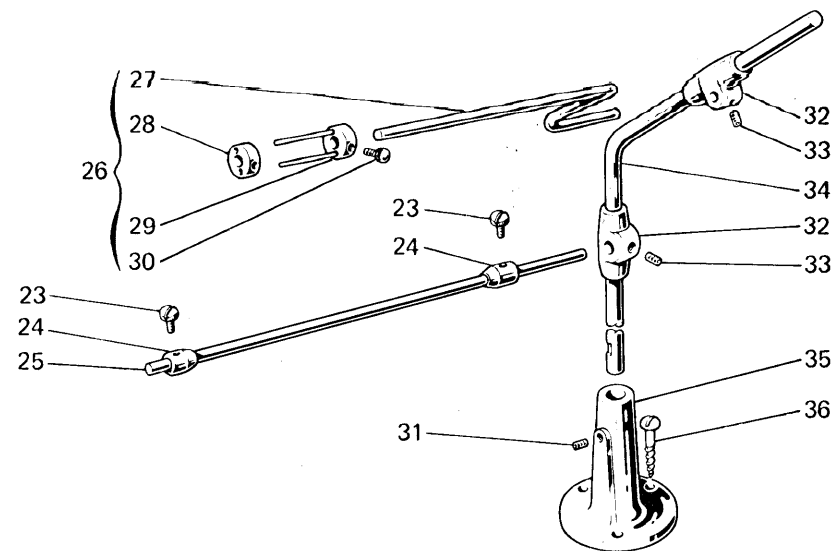
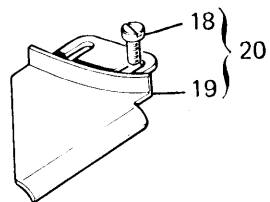
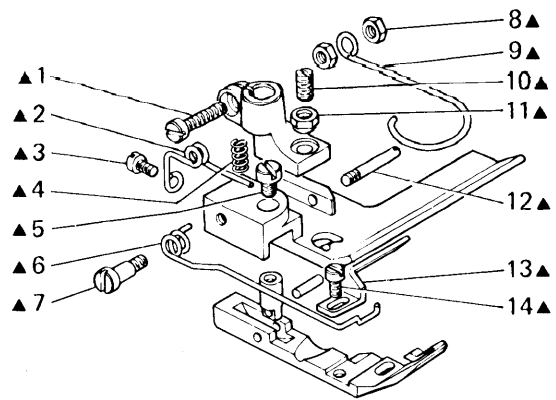

Fig. N. Abb. N.	Part. N. Piece N. Bestell N. Pieza N.	Qt. Anzahl	DESCRIZIONE	DESCRIPTION	DESCRIPTION	BENENNUNG	DESCRIPCION
45	302767-0-10	1	molla	spring	ressort		
46	302770-0-10	1	pomolo	knob	pommeau		
47	310043-4-00	1	guida regolabile completa	control guide assembly	guide réglable complet		

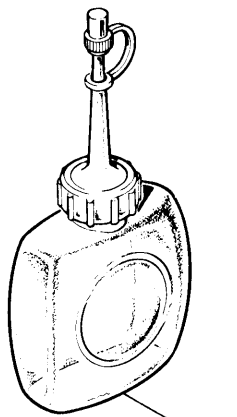
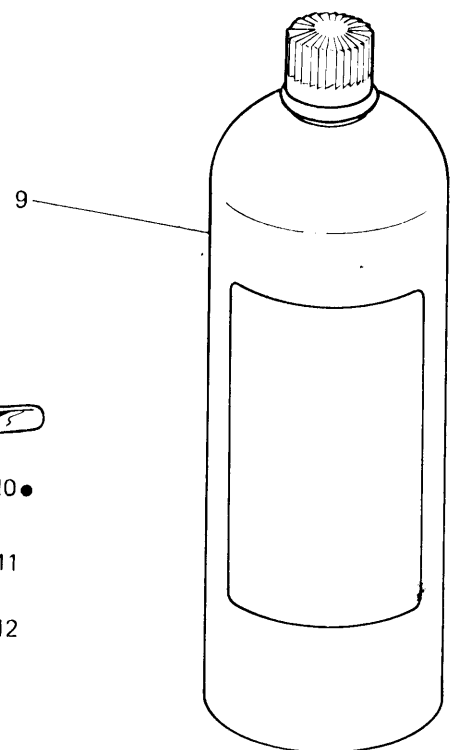
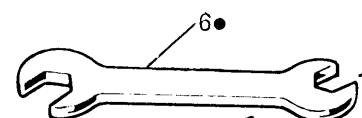
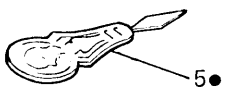
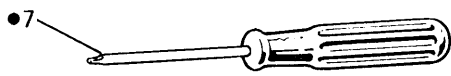
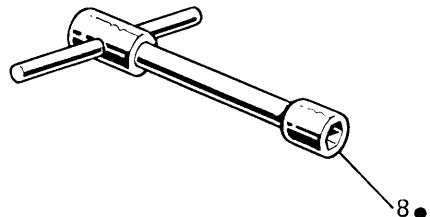
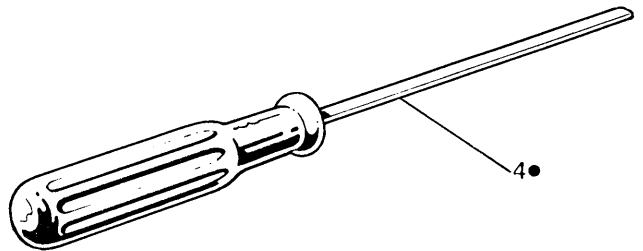
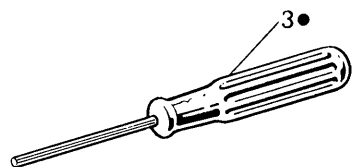
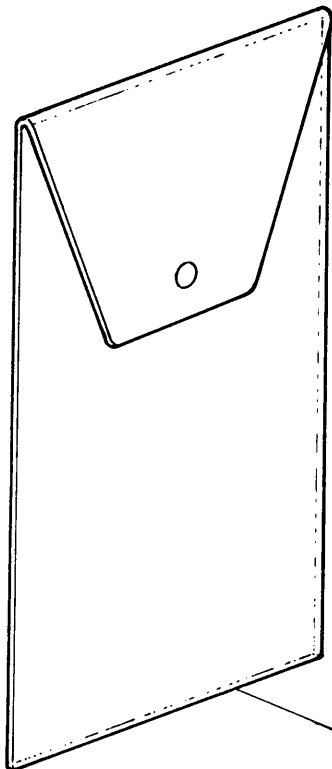

Fig. N. Abb. N.	Part. N. Piec. N. Bestell N. Pieza N.	Qt. Anzahl	DESCRIZIONE	DESCRIPTION	DESCRIPTION	BENENNUNG	DESCRIPCION
●	991408-4-00	1	busta accessori completa	accessories envelope assembly	envelope accessoires complète		
1	991415-0-00	1	busta accessori	accessories envelope	envelope accessoires		
2	990175-0-10	1	oliatore	oiler	graisseur		
3	990474-0-11	1	chiave esagonale da 1,5 mm	1,5 mm hexagonal key	clé hexagonale da 1,5 mm		
4	990181-0-10	1	cacciavite medio	screw-driver	tournevis moyen		
5	990188-0-10	1	infila aghi	needle threading	enfiles aiguilles		
6	990193-0-00	1	chiave da 5-7 mm	5-7 mm key	clé da 5-7 mm		
7	990182-0-10	1	cacciavite piccolo	screw driver	petite tournevis		
8	990587-0-10	1	chiave a tubo da 9 mm	9 mm key	clé à tube de 9 mm		
9	990075-1-13	1	lattina olio kg.1	oil container (1kg.)	bidon huile de 1 kg.		
10	990176-0-10	1	pinza per infilatura	threading tweezers	pince pour infilage		
11	990578-0-12	1	cuffia protez.macchina	machine cover	couverture protection machine		
12	★	1	bustina aghi	needle packet	paquette aiguille		
			★per l'ordinazione della bustina citare lo stesso simbolo dell'ago montato sulla testa	★to order packet of needles please specify symbol of needle fitted on machine	★pour commander un sachet d'aiguilles donner le symbol de l'aiguille montée sur la tête		

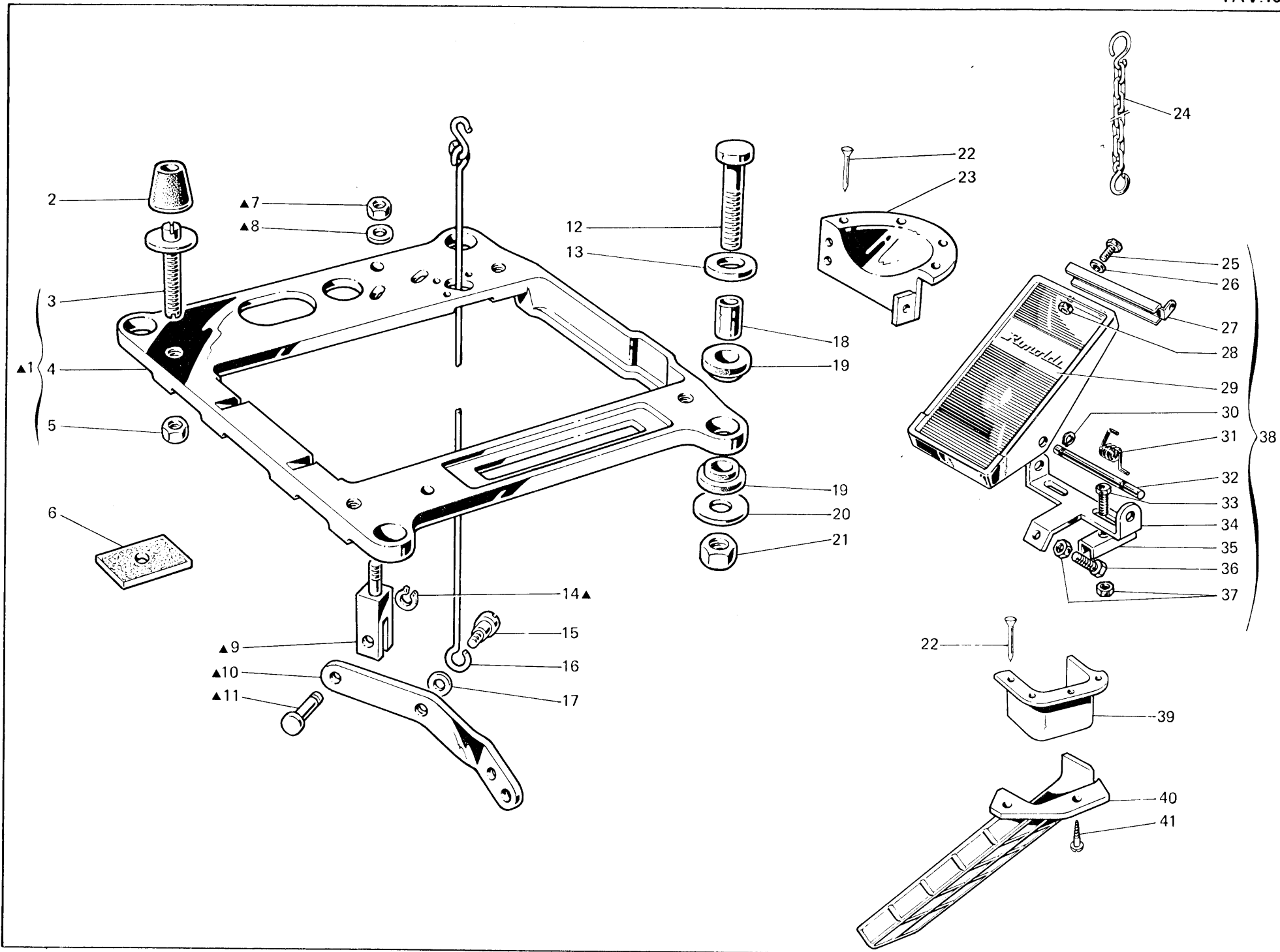

Fig. N. Abb. N.	Part. N. Bestell N. Piece N. Pieza N.	Qt. Anzahl	DESCRIZIONE	DESCRIPTION	DESCRIPTION	BENENNUNG	DESCRIPCION
▲	991253-4-00	1	PIAZZAMENTO NORMALE	NORMAL SETTING	INSTALLATION NORMAL		
1	991251-4-00	1	supporto testa completo	head support assembly	support tête complet		
2	990982-0-00	4	supporto testa con perno	head support with pin	support tête avec pivot		
3	990694-0-11	4	ammortizzatore	shock absorber	amortisseur		
4	991250-0-00	1	perno	pin	pivot		
5	733008-2-00	4	supporto testa	head support	support tête		
6	900203-0-10	4	dado	nut	écrou		
7	746409-2-00	4	ammortizzatore per tavola	shock absorber	amortisseur pour table		
8	704316-2-00	1	dado	nut	écrou		
9	704316-2-00	1	rondella	washer	rondelle		
10	991256-0-00	1	supportino per leva	support for lever	support pour levier		
11	991255-0-00	1	leva	lever	levier		
12	991257-0-00	1	perno	pin	pivot		
13	722905-2-00	4	vite	screw	vis		
14	704346-2-00	4	rondella	washer	rondelle		
15	700208-0-00	1	anello elastico	spring ring	anneau ressort		
16	743541-2-00	1	vite	screw	vis		
17	991259-3-00	1	tirante	tie-rod	tirant		
18	704310-2-00	1	rondella	washer	rondelle		
19	901102-0-00	4	distanziale	spacer	entretoise		
20	901101-0-00	8	ammortizzatore	shock absorber	amortisseur		
21	704345-2-00	4	rondella	washer	rondelle		
22	733813-0-00	4	dado	nut	écrou		
23	900201-0-10	13	chiodini	rivets	clous		
24	990317-0-10	1	protezione volante	handwheel protection	protection volant		
25	990179-4-11	1	catenella	chain	chainette		
26	720464-0-00	2	vite	screw	vis		
27	704009-4-00	2	rondella	washer	rondelle		
28	900926-0-00	1	attacco	coupling	raccord		
29	733508-4-00	2	dado	nut	écrou		
30	900931-0-00	1	copertura	covering	couverture		
31	900918-0-00	2	anello elastico	spring ring	anneau ressort		
32	900927-0-00	1	molla	spring	ressort		
33	900928-0-00	1	perno	pin	pivot		
34	720505-4-00	2	vite	screw	vis		
35	900929-0-01	1	supporto	support	support		
36	900920-0-00	2	piatrina	plate	plaquette		
37	720545-4-00	1	vite	screw	vis		
38	733510-4-00	3	dado	nut	écrou		
39	900925-4-01	1	pedalina completa	pedal assembly	pédale complète		
40	990675-0-10	1	bocchetta	cup	bouche		
41	990674-0-00	1	canale scarica ritagli	offlet	canal décharge-chutes		
42	731086-0-00	2	vite da legno	screw	vis		

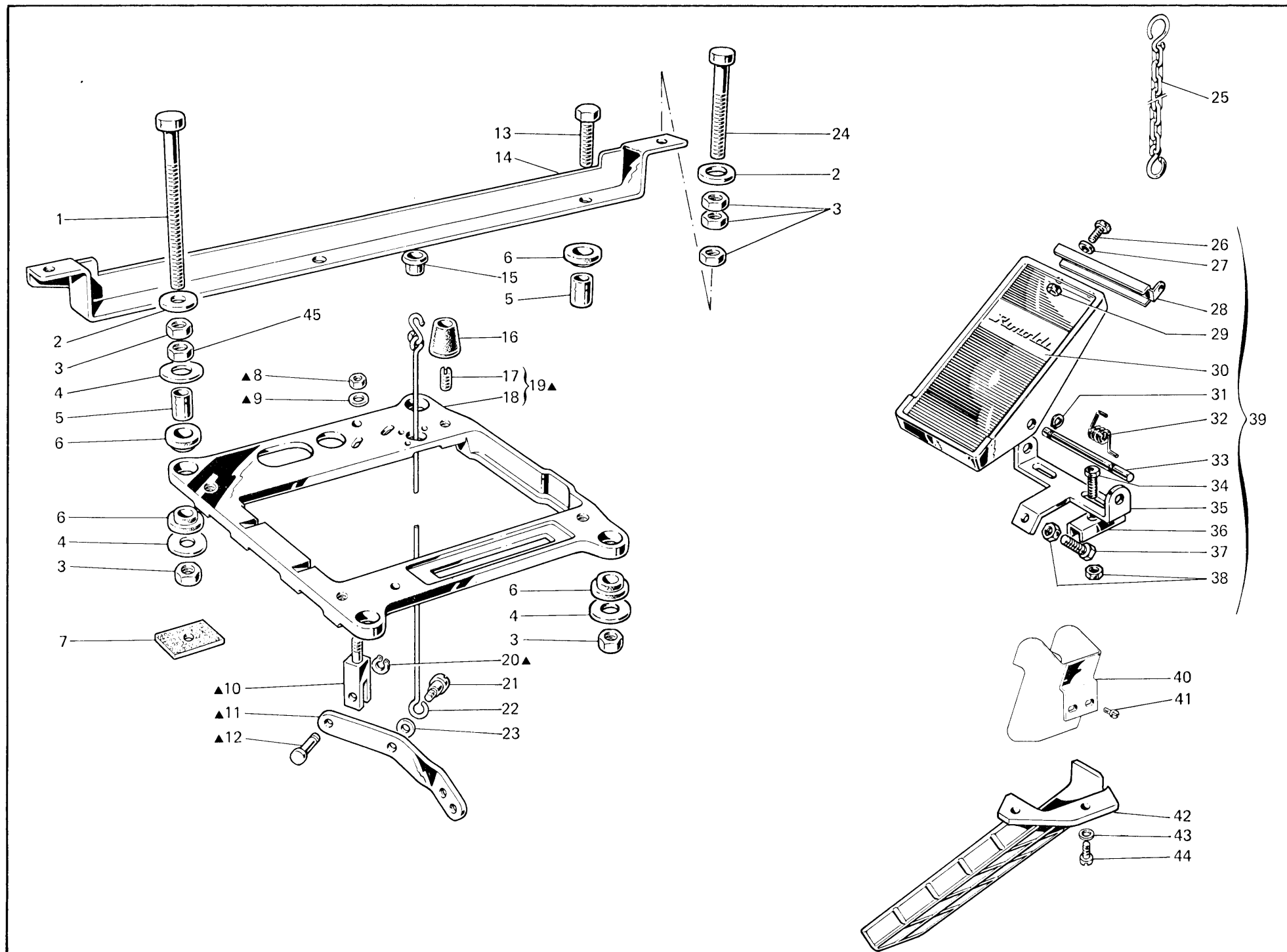

Fig. N. Abb. N.	Part. N. Piecce N. Bestell N. Pieza N.	Qt. Anzahl	DESCRIZIONE	DESCRIPTION	DESCRIPTION	BENENNUNG	DESCRIPCION
			PIAZZAMENTO INCASSATO	SUBMERGED SETTING	INSTALLATION ENCASTREE		
▲	991254-4-00	1	supporto testa completo	head support assembly	support tête complet		
1	722920-2-00	2	vite	screw	vis		
2	704346-2-00	4	rondella	washer	rondelle		
3	733813-0-00	10	dado	nut	écrou		
4	704345-2-00	6	rondella	washer	rondelle		
5	901102-0-00	4	distanziale	spacer	entretoise		
6	901101-0-00	8	ammortizzatore	shock absorber	amortisseur		
7	900203-0-10	4	ammortizzatore per tavola	shock absorber	amortisseur pour table		
8	746409-2-00	1	dado	nut	écrou		
9	704316-2-00	1	rondella	washer	rondelle		
10	991256-0-00	1	supportino per leva	support for lever	support pour levier		
11	991255-0-00	1	leva	lever	levier		
12	991257-0-00	1	perno	pin	pivot		
13	720546-0-00	2	vite	screw	vis		
14	901255-2-00	1	staffa	bracket	bride		
15	900204-0-10	1	bussola	bush	bague		
16	990982-0-00	4	ammortizzatore	shock absorber	amortisseur		
17	901253-0-00	4	vite	screw	vis		
18	991250-0-00	1	supporto testa	head support	support tête		
19	991252-4-00	1	supporto testa con viti	head support with screws	support tête avec vis		
20	700208-0-00	1	anello elastico	spring ring	anneau ressort		
21	743541-2-00	1	vite	screw	vis		
22	991259-3-00	1	tirante	tie-rod	tirant		
23	704310-2-00	1	rondella	washer	rondelle		
24	722907-2-00	2	vite	screw	vis		
25	990179-4-11	1	catenella	chain	chainette		
26	720464-0-00	2	vite	screw	vis		
27	704009-4-00	2	rondella	washer	rondelle		
28	990926-0-00	1	attacco	coupling	raccord		
29	733508-4-00	2	dado	nut	écrou		
30	900931-0-00	1	copertura	covering	couverture		
31	900918-0-00	2	anello elastico	spring ring	anneau ressort		
32	900927-0-00	1	molla	spring	ressort		
33	900928-0-00	1	perno	pin	pivot		
34	720505-4-00	2	vite	screw	vis		
35	900929-0-01	1	supporto	support	support		
36	900920-0-00	2	piastrina	plate	plaque		
37	720545-4-00	1	vite	screw	vis		
38	733510-4-00	3	dado	nut	écrou		
39	900925-4-01	1	pedalina completa	pedal assembly	pédale complète		
40	990689-2-00	1	convogliatore	conveyor	conveyeur		
41	721434-2-00	2	vite	screw	vis		
42	990674-0-00	1	canale scarico ritagli	offlet	canal décharge-chutes		
43	704409-2-00	2	rondella	washer	rondelle		
44	721475-2-00	2	vite	screw	vis		
45	733008-2-00	4	dado	nut	écrou		



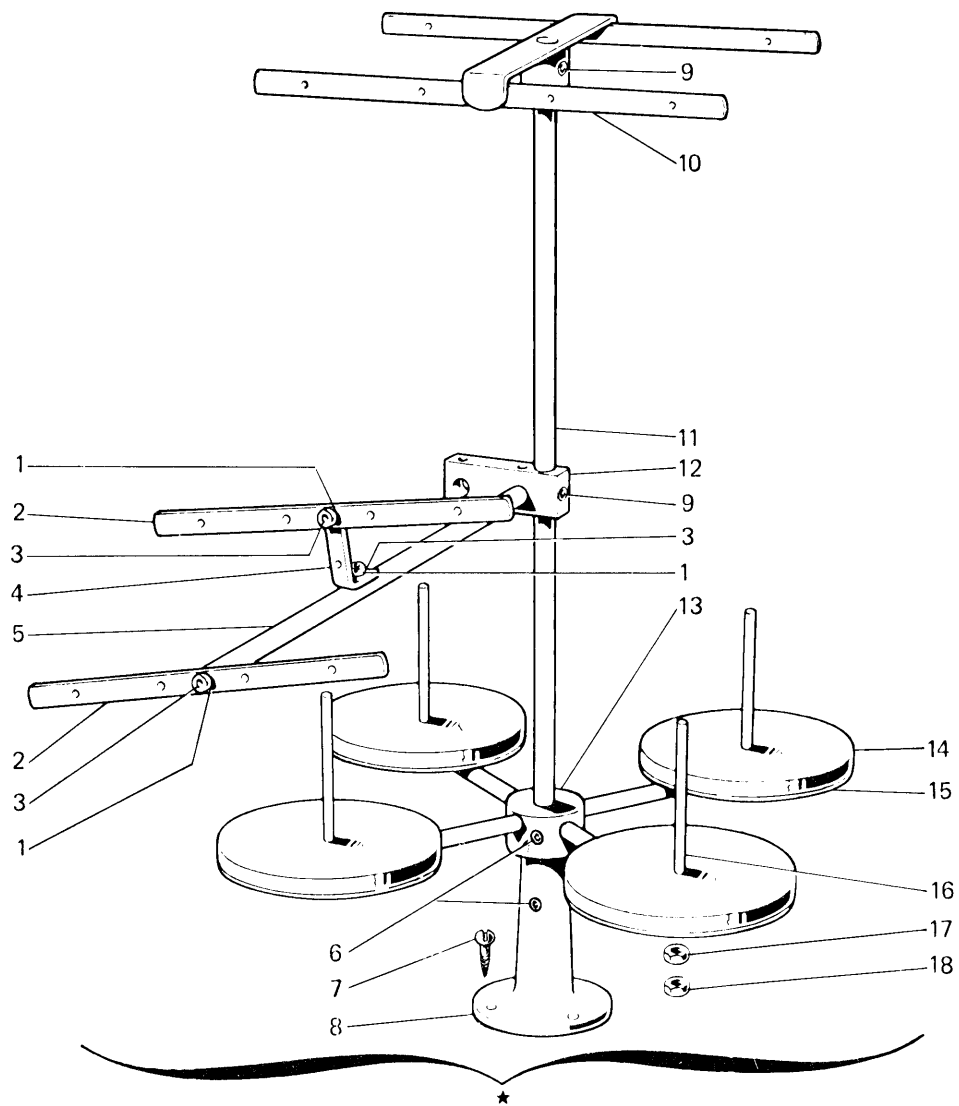
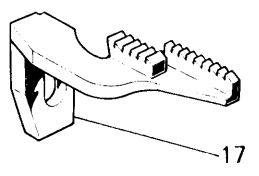
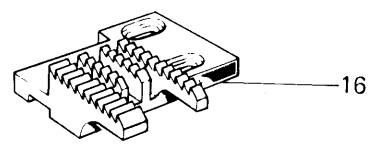
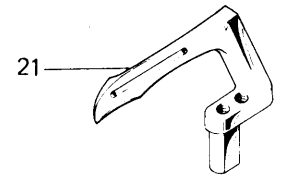
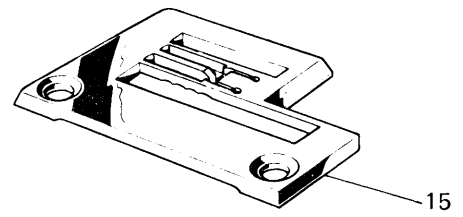
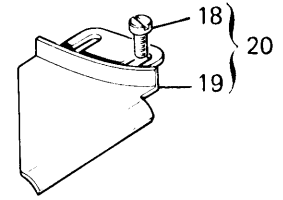
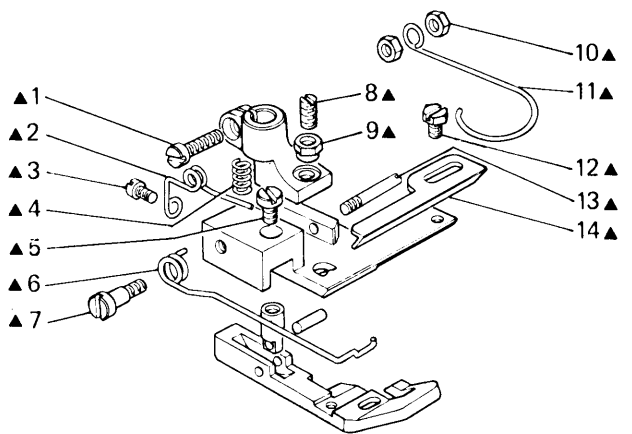
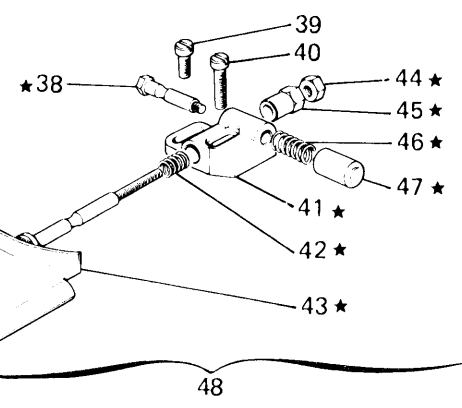
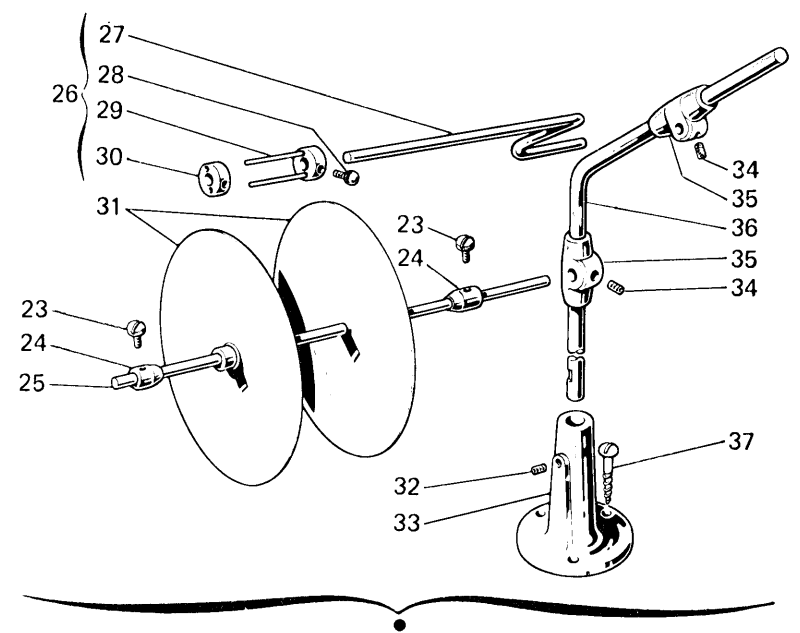

Fig. N. Abb. N.	Part. N. Piece N. Bestell N. Pieza N.	Qt. Anzahl	DESCRIZIONE	DESCRIPTION	DESCRIPTION	BENENNUNG	DESCRIPCION
★	991120-5-00	1	porta bobine compl.(4-3 fili)	bobbin carrier ass.(3-4 threads)	porte bobine compl. (4-3 fils)		
1	703005-0-00	3	rondella	washer	rondelle		
2	991108-2-00	2	tubetto con bussole	frame with bushes	bâti avec bagues		
3	722431-2-00	3	vite	screw	vis		
4	991107-2-00	1	squadretta con viti e rondelle	bracket with screws and washers	équerre avec vis et rondelles		
5	991106-2-00	1	asta con rondelle e viti	rod with washers and screws	tige avec rondelles et vis		
6	729054-2-00	3	vite	screw	vis		
7	731107-2-00	3	vite	screw	vis		
8	991114-2-00	1	basetta	base	base		
9	729034-2-00	3	vite	screw	vis		
10	991121-3-00	1	telaietto superiore	upper frame	bâti supérieur		
11	991113-0-00	1	asta principale	main rod	tige principale		
12	991128-2-00	1	blocchetto con viti	block with screws	bloc avec vis		
13	991129-3-00	1	mozzo con aste e viti	hub with rod and screws	moyeu avec tiges et vis		
14	991179-0-00	4	disco	disc	disque		
15	991112-0-00	4	piatto	disc	plateau		
16	991111-2-00	4	astina con dadi	rod with nuts	tige avec écrous		
17	733508-2-00	4	dado	nut	écrou		
18	925433-0-00	4	dado	nut	écrou		



SpA V. Remoide - C. Milano  
Made in Italy

22



48

Fig. N. Abb. N.	Part. N. Bestell N. Piecce N. Pieza N.	Qt. Anzahl	DESCRIZIONE	DESCRIPTION	DESCRIPTION	BENENNUNG	DESCRIPCION
▲	306681-3-00	1	piedino completo	presserfoot assembly			
●	991325-4-00	1	porta rotolo completo	roll carrier assembly			
1	741781-2-00	1	vite	screw			
2	300119-0-11	1	molla	spring			
3	721411-2-00	1	vite	screw			
4	303052-0-00	1	molla	spring			
5	741414-2-00	1	vite	screw			
6	302821-0-10	1	molla	spring			
7	743134-2-00	1	vite	screw			
8	301596-0-11	1	vite	screw			
9	301598-0-11	1	dado	nut			
10	733504-2-00	2	dado	nut			
11	990808-0-01	1	salvadita	protection			
12	203658-0-10	1	vite	screw			
13	300120-0-10	1	spina filettata	pin			
14	304411-0-11	1	guida	guide			
15	302810-0-10	1	placca ago	needle plate			
16	302795-0-10	1	griffa principale	main feed dog			
17	302797-0-10	1	griffa differenziale	gdifferential feed dog			
18	721434-2-00	2	vite	screw			
19	302851-2-10	1	guida	guide			
20	310040-4-00	1	guida con viti	guide with screws			
21	302057-0-11	1	crochet inferiore	lower looper			
22	784300-0-20	1	targhetta classe testa	head class plate			
23	990596-0-10	2	pomolo	knob			
24	990594-2-00	2	anello di registro con pomolo	adjustment ring with knob			
25	990593-0-11	1	spina	pin			
26	990705-4-11	1	passa nastro	strap guide			
27	990704-0-11	1	spina	pin			
28	990708-0-10	1	morsetto	clamp			
29	990707-2-10	1	morsetto con spine	clamp with pins			
30	930096-0-10	2	pomolo	knob			
31	990612-2-10	2	disco	disc			
32	729054-2-00	1	vite	screw			
33	991114-2-00	1	basetta con vite	base with screw			
34	729024-2-00	4	vite	screw			
35	991153-2-00	2	supporto con viti	support with screws			
36	990703-0-11	1	asta	rod			
37	731107-2-00	3	vite da legno	screw			
			SOLO A RICHIESTA	ONLY ON REQUEST			SEULEMENT SUR DEMANDE
★	302765-4-10	1	guida regolabile	control guide			guide réglable
38	302762-0-10	1	perno	pin			pivot
39	721474-2-00	1	vite	screw			vis
40	721494-2-00	1	vite	screw			vis
41	302768-0-10	1	blocchetto	block			bloc
42	302766-0-10	1	molla	spring			ressort
43	302764-2-10	1	guida	guide			guide
44	746021-2-00	1	dado	nut			écrou

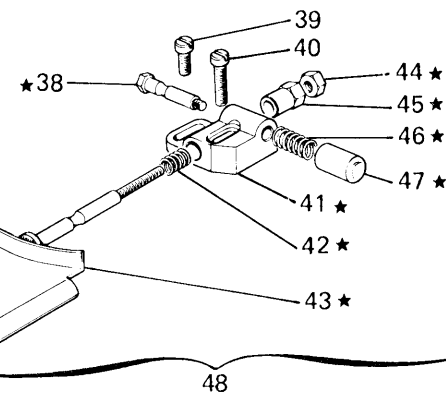
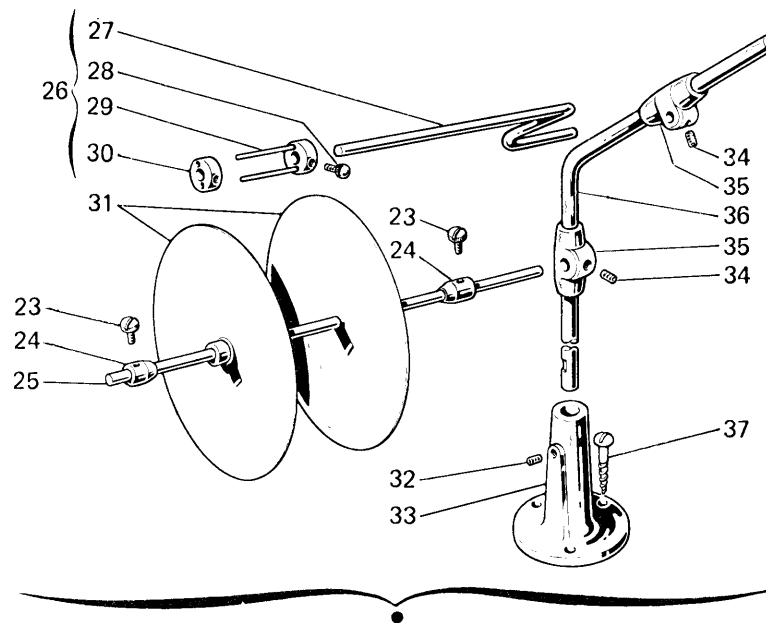
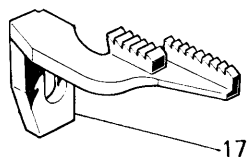
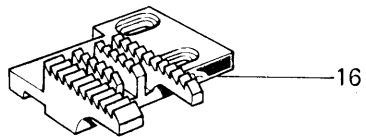
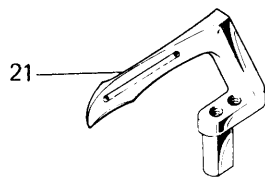
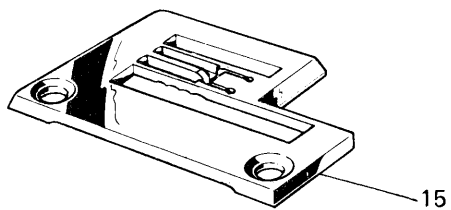
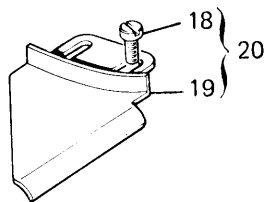
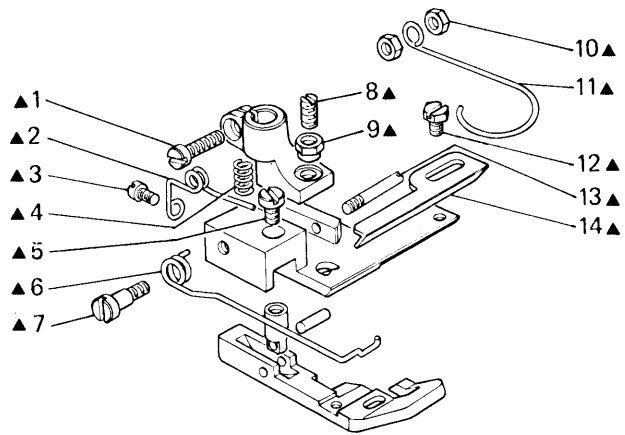
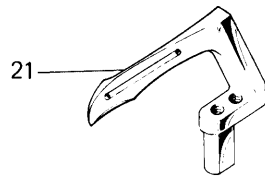
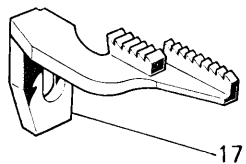
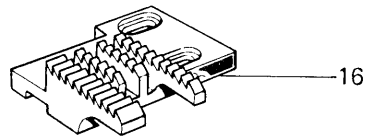
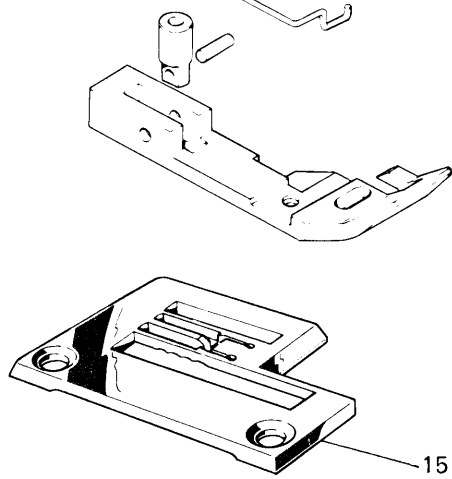
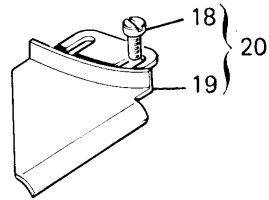
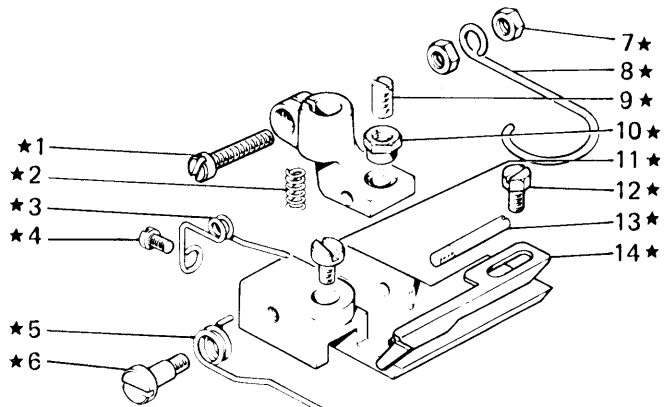

Fig. N. Abb. N.	Part. N. Bestell N. Piece N. Pieza N.	Qt. Anzahl	DESCRIZIONE	DESCRIPTION	DESCRIPTION	BENENNUNG	DESCRIPCION
45	302769-0-10	1	pomolo	knob			
46	302767-0-10	1	molla	spring			
47	302770-0-10	1	pomolo	knob			
48	310043-4-00	1	guida regolabile completa	control guide assembly			
					pommeau		
					ressort		
					pommeau		
					guide réglable complet		
45	<u>Tav. 4</u> 302842-0-10	1	squadretta	bracket			
					équerre		
▲	<u>Tav. 10</u> 309806-4-00	1	morsetto porta aghi compl.	needles clamp assembly			
26	309756-2-00	1	morsetto porta aghi	needles clamp			
42	309770-0-00	1	passafilo	thread guide			
					porte-aiguilles complet		
					porte-aiguilles		
					passe-fil		



SpA V. Remotola e C. Milano  
Made in Italy

22

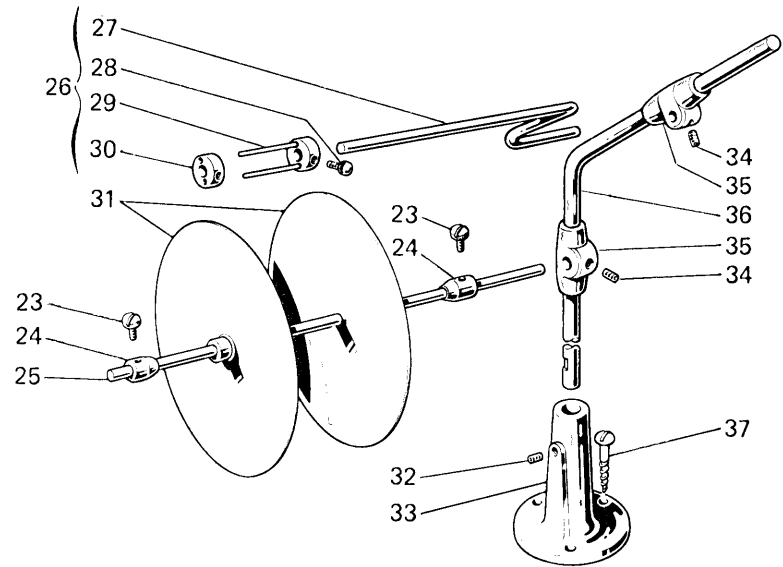

Fig. N. Abb. N.	Part. N. Bestell N. Piece N. Pieza N.	Qt. Anzahl	DESCRIZIONE	DESCRIPTION	DESCRIPTION	BENENNUNG	DESCRIPCION
★	306678-3-00	1	piedino completo	presserfoot assembly	pied-presseur complet		
●	991325-4-00	1	porta rotolo	roll carrier	porte-rouleau		
1	741781-2-00	1	vite	screw	vis		
2	303052-0-00	1	molla	spring	ressort		
3	300119-0-11	1	molla	spring	ressort		
4	721411-2-00	1	vite	screw	vis		
5	302821-0-10	1	molla	spring	ressort		
6	743134-2-00	1	vite	screw	vis		
7	733504-2-00	2	dado	nut	écrou		
8	990808-0-01	1	salvadita	protection	protection		
9	301596-0-11	1	vite	screw	vis		
10	301598-0-11	1	dado	nut	écrou		
11	741414-2-00	1	vite	screw	vis		
12	203658-0-10	1	vite	screw	vis		
13	300120-0-10	1	spina filettata	pin	goupille		
14	304411-0-11	1	guida	guide	guide		
15	302880-0-10	1	placca ago	needle plate	plaque aiguille		
16	302795-0-10	1	griffa principale	main feed dog	griffe principale		
17	302797-0-10	1	griffa differenziale	differential feed dog	griffe différentielle		
18	721434-2-00	2	vite	screw	vis		
19	302851-2-10	1	guida	guide	guide		
20	310040-4-00	1	guida con viti	guide with screws	guide avec vis		
21	302057-0-11	1	crochet inferiore	lower looper	crochet inférieur		
22	784300-0-20	1	targhetta classe testa	head class plate	plaque classe tête		
23	990596-0-10	2	pomolo	knob	pommeau		
24	990594-2-00	2	anello di registro con pomolo	adjustment ring with knob	anneau de réglage avec pommeau		
25	990593-0-11	1	spina	pin	goupille		
26	990705-4-11	1	passa nastro	strap guide	guide pour bande		
27	990704-0-11	1	spina	pin	goupille		
28	990708-0-10	1	morsetto	clamp	bride		
29	990707-2-10	1	morsetto con spine	clamp with pins	bride avec goupilles		
30	930096-0-10	2	pomolo	knob	pommeau		
31	990612-2-10	2	disco	disc	disque		
32	729054-2-00	1	vite	screw	vis		
33	991114-2-00	1	basetta con vite	base with screw	base avec vis		
34	729024-2-00	4	vite	screw	vis		
35	991153-2-00	2	supporto con viti	supporto with screws	support avec vis		
36	990703-0-11	1	asta	rod	tige		
37	731107-2-00	3	vite da legno	screw	vis		



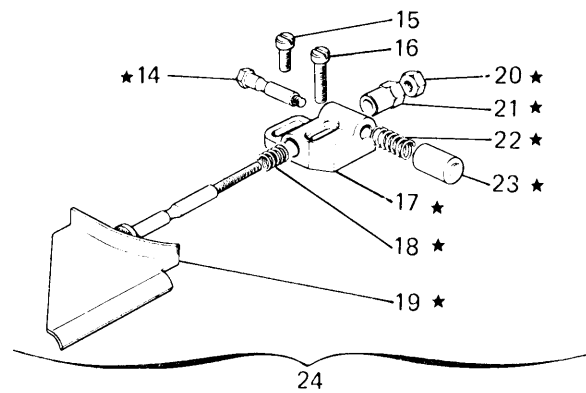
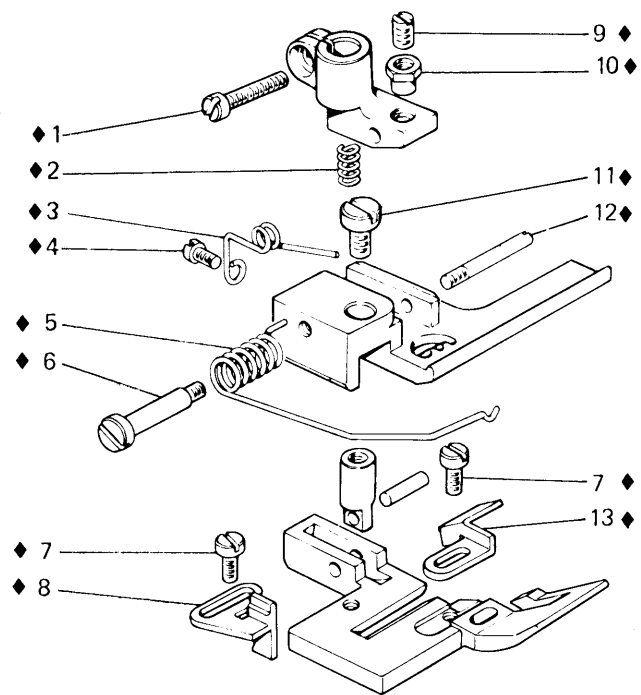

Fig. N. Abb. N.	Part. N. Bestell N. Piece N. Pieza N.	Qt. Anzahl	DESCRIZIONE	DESCRIPTION	DESCRIPTION	BENENNUNG	DESCRIPCION
			SOLO A RICHIESTA	ONLY ON REQUEST	SEULEMENT SUR DEMANDE		
◆	302882-3-02	1	piedino completo	presserfoot assembly	pie-dresseur complet		
★	302765-4-10	1	guida regolabile	control guide	guide réglable		
1	741721-2-00	1	vite	screw	vis		
2	303052-0-00	1	molla	spring	ressort		
3	300119-0-11	1	molla	spring	ressort		
4	721411-2-00	1	vite	screw	vis		
5	302872-0-10	1	molla	spring	ressort		
6	302870-0-10	1	vite	screw	vis		
7	741413-2-00	2	vite	screw	vis		
8	302883-0-00	1	guida pizzo	guide	guide		
9	301596-0-11	1	vite	screw	vis		
10	301598-0-11	1	dado	nut	écrou		
11	741414-2-00	1	vite	screw	vis		
12	300120-0-10	1	spina filettata	pin	goupille		
13	302877-0-00	1	guida elastico	guide	guide		
14	302762-0-10	1	perno	pin	pivot		
15	721474-2-00	1	vite	screw	vis		
16	721494-2-00	1	vite	screw	vis		
17	302768-0-10	1	blocchetto	block	bloc		
18	302766-0-10	1	molla	spring	ressort		
19	302764-2-10	1	guida	guide	guide		
20	746021-2-00	1	dado	nut	écrou		
21	302769-0-10	1	pomolo	knob	pommeau		
22	302767-0-10	1	molla	spring	ressort		
23	302770-0-10	1	pomolo	knob	pommeau		
24	310043-4-00	1	guida regolabile completa	control guide assembly	guide réglable complet		
45	<u>Tav. 4</u> 302842-0-10	1	squadretta	bracket	équerre		
▲	<u>Tav. 10</u> 309807-4-00	1	morsetto porta aghi completo	needles clamp assembly	porte-aiguilles complet		
26	309757-2-00	1	morsetto porta aghi	needles clamp	porte-aiguilles		
28	766000-6-90	2	ago sist.Rim 63 fin.90	needle syst.Rim 63 size 90	aiguille syst.Rim 63 jauge 90		
42	309770-0-00	1	passafilo	thread guide	passe-fil		

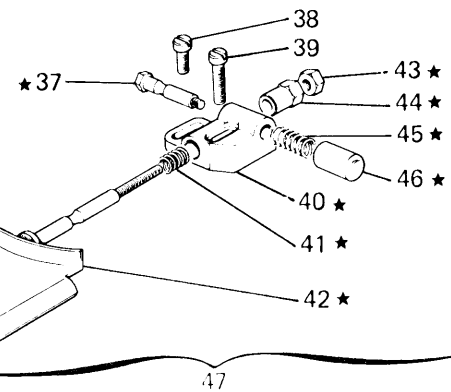
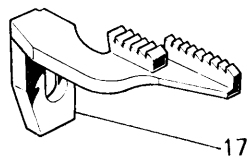
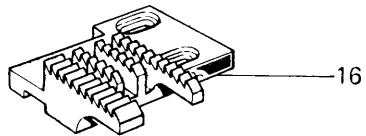
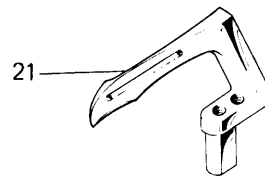
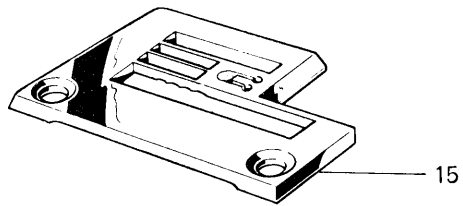
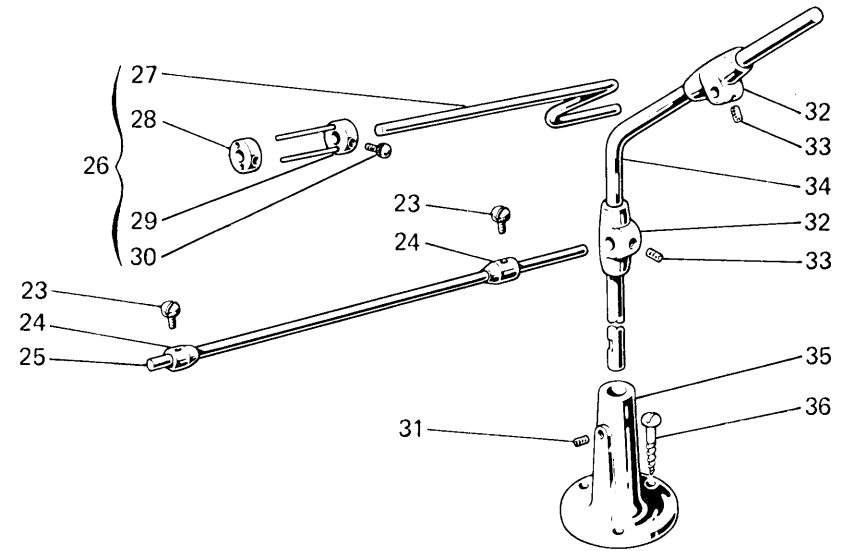
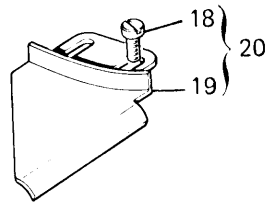
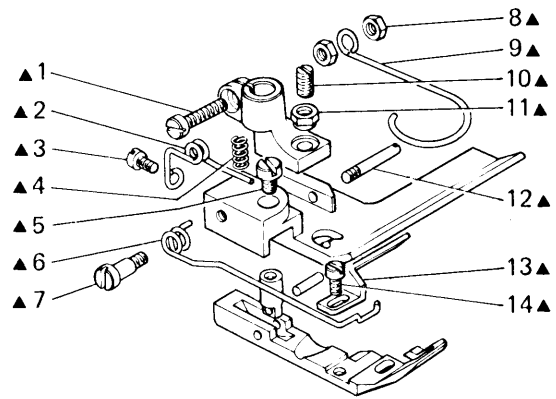

Fig. N. Abb. N.	Part. N. Bestell N. Piece N. Pieza N.	Qt. Anzahl	DESCRIZIONE	DESCRIPTION	DESCRIPTION	BENENNUNG	DESCRIPCION
▲	306679-3-00	1	pieдино completo	presserfoot assembly	pieд presseur complet		
●	990709-4-12	1	porta rotolo completo	roll carrier assembly	porte-rouleau complet		
1	741781-2-00	1	vite	screw	vis		
2	300119-0-11	1	molla	spring	ressort		
3	721411-2-00	1	vite	screw	vis		
4	303052-0-00	1	molla	spring	ressort		
5	741414-2-00	1	vite	screw	vis		
6	302821-0-10	1	molla	spring	ressort		
7	743134-2-00	1	vite	screw	vis		
8	733504-2-00	2	dado	nut	écrou		
9	990808-0-01	1	salvadita	protection	protection		
10	301596-0-11	1	vite	screw	vis		
11	301598-0-11	1	dado	nut	écrou		
12	300120-0-10	1	spina	pin	goupille		
13	302773-0-11	1	guida	guide	guide		
14	741413-2-00	1	vite	screw	vis		
15	302754-0-10	1	placca ago	needle plate	plaque aiguille		
16	302796-0-10	1	griffa principale	main feed dog	griffe principale		
17	302798-0-10	1	griffa differenziale	differential feed dog	griffe différentielle		
18	721434-2-00	2	vite	screw	vis		
19	302851-2-10	1	guida	guide	guide		
20	310040-4-00	1	guida con viti	guide with screws	guide avec vis		
21	302057-0-11	1	crochet inferiore	lower looper	crochet inférieur		
22	784300-0-20	1	targhetta classe testa	head class plate	plaque classe tête		
23	990596-0-10	2	pomolo	knob	pommeau		
24	990594-2-00	2	anello di registro con pomolo	adjustment ring with knob	anneau de réglage avec pommeau		
25	990593-0-11	1	spina	pin	goupille		
26	990705-4-11	1	passa nastro	strap guide	guide pour bande		
27	990704-0-11	1	spina	pin	goupille		
28	990708-0-10	1	morsetto	clamp	bride		
29	990707-2-10	1	morsetto con spine	clamp with pins	bride avec pivots		
30	930096-0-10	2	pomolo	knob	pommeau		
31	729054-2-00	1	vite	screw	vis		
32	991153-2-00	1	supporto con viti	support with screws	support avec vis		
33	729024-2-00	4	vite	screw	vis		
34	990703-0-11	1	asta	rod	tige		
35	991114-2-00	1	basetta con vite	base with screw	base avec vis		
36	731107-2-00	3	vite da legno	screw	vis		
			SOLO A RICHIESTA	ONLY ON REQUEST	SEULEMENT SUR DEMANDE		
★	302765-4-10	1	guida regolabile	control guide	guide réglable		
37	302762-0-10	1	perno	pin	pivot		
38	721474-2-00	1	vite	screw	vis		
39	721494-2-00	1	vite	screw	vis		
40	302768-0-10	1	blocchetto	block	bloc		
41	302766-0-10	1	molla	spring	ressort		
42	302764-2-10	1	guida	guide	guide		
43	746021-2-00	1	dado	nut	écrou		
44	302769-0-10	1	pomolo	knob	pommeau		

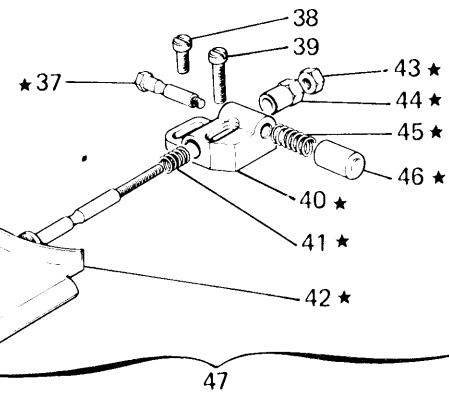
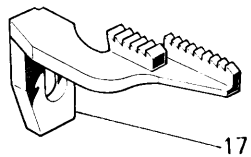
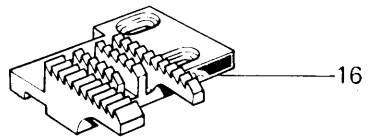
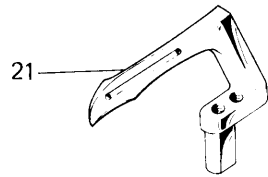
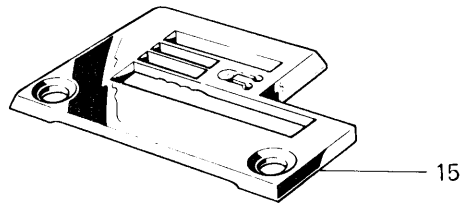
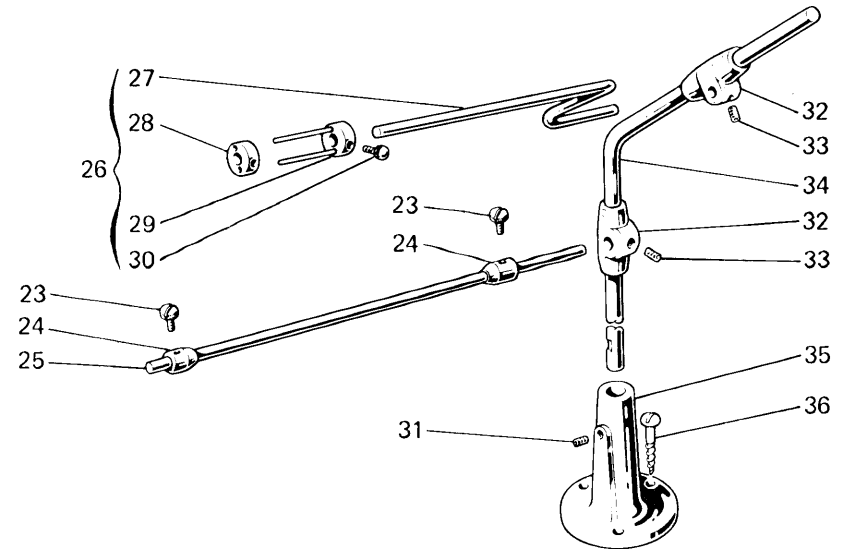
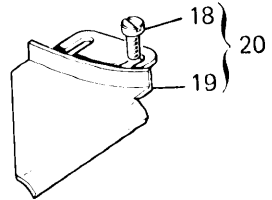
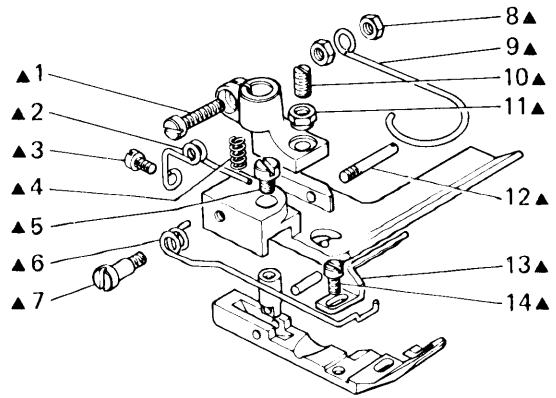

Fig. N. Abb. N.	Part. N. Piece N. Bestell N. Pieza N.	Qt. Anzahl	DESCRIZIONE	DESCRIPTION	DESCRIPTION	BENENNUNG	DESCRIPCION
45	302767-0-10	1	molla	spring	ressort		
46	302770-0-10	1	pomolo	knob	pommeau		
47	310043-4-00	1	guida regolabile completa	control guide assembly	guide réglable complet		
▲ 26	<u>Tav. 10</u> 309804-4-00 309754-0-00	1 1	morsetto porta aghi compl. morsetto porta aghi	needles clamp assembly needles clamp	porte-aiguilles complet porte-aiguilles		

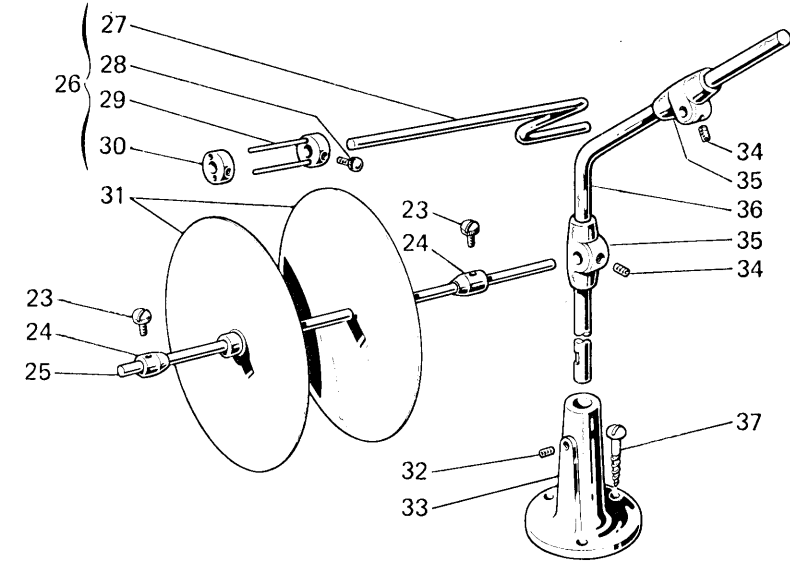
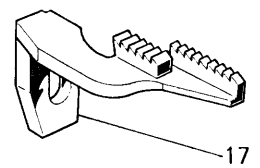
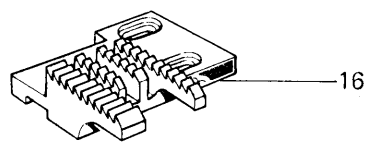
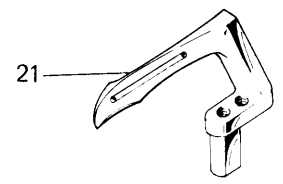
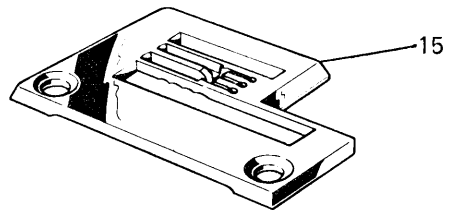
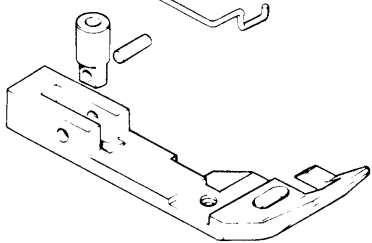
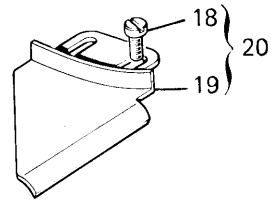
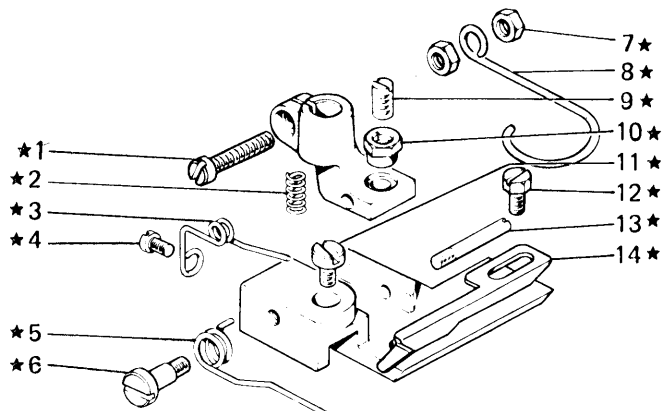

Fig. N. Abb. N.	Part. N. Bestell N. Piece N. Pieza N.	Qt. Anzahl	DESCRIZIONE	DESCRIPTION	DESCRIPTION	BENENNUNG	DESCRIPCION
★	306678-3-00	1	pedino completo	presserfoot assembly	ped-presseur complet		
●	991325-4-00	1	porta rotolo	roll carrier	porte-rouleau		
1	741781-2-00	1	vite	screw	vis		
2	303052-0-00	1	molla	spring	ressort		
3	300119-0-11	1	molla	spring	ressort		
4	721411-2-00	1	vite	screw	vis		
5	302821-0-10	1	molla	spring	ressort		
6	743134-2-00	1	vite	screw	vis		
7	733504-2-00	2	dado	nut	écrou		
8	990808-0-01	1	salvadita	protection	protection		
9	301596-0-11	1	vite	screw	vis		
10	301598-0-11	1	dado	nut	écrou		
11	741414-2-00	1	vite	screw	vis		
12	203658-0-10	1	vite	screw	vis		
13	300120-0-10	1	spina filettata	pin	pivot		
14	304411-0-11	1	guida	guide	guide		
15	302735-0-10	1	placca ago	needle plate	plaque aiguille		
16	302795-0-10	1	griffa principale	main feed dog	griffe principale		
17	302797-0-10	1	griffa differenziale	differential feed dog	griffe différentielle		
18	721434-2-00	2	vite	screw	vis		
19	302851-2-10	1	guida	guide	guide		
20	310040-4-00	1	guida con viti	guide with screws	guide avec vis		
21	302057-0-11	1	crochet inferiore	lower looper	crochet inférieur		
22	784300-0-20	1	targhetta classe testa	head class plate	plaque classe tête		
23	990596-0-10	2	pomolo	knob	pommeau		
24	990594-2-00	2	anello di registro con pomolo	adjustment ring with knob	anneau de réglage avec pommeau		
25	990593-0-11	1	spina	pin	goupille		
26	990705-4-11	1	passa nastro	strap guide	guide pour bande		
27	990704-0-11	1	spina	pin	goupille		
28	990708-0-10	1	morsetto	clamp	bride		
29	990707-2-10	1	morsetto con spine	clamp with pins	bride avec pivots		
30	930096-0-10	2	pomolo	knob	pommeau		
31	990612-2-10	2	disco	disc	disque		
32	729054-2-00	1	vite	screw	vis		
33	991114-2-00	1	basetta con vite	base with screw	base avec vis		
34	729024-2-00	4	vite	screw	vis		
35	991153-2-00	2	supporto con viti	support with screws	support avec vis		
36	990703-0-11	1	asta	rod	tige		
37	731107-2-00	3	vite da legno	screw	vis		
15	302738-0-00	1	SOLO A RICHIESTA placca ago	ONLY ON REQUEST needle plate	SEULEMENT SUR DEMANDE plaque aiguille		



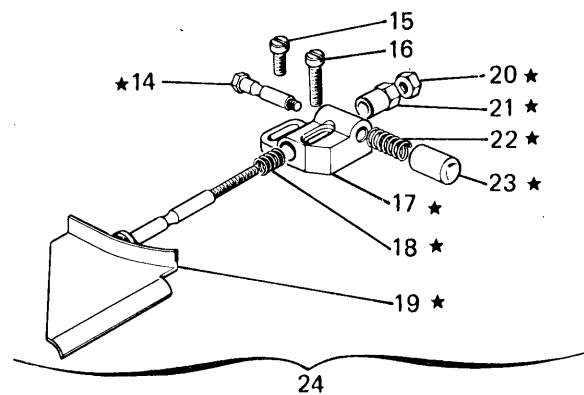
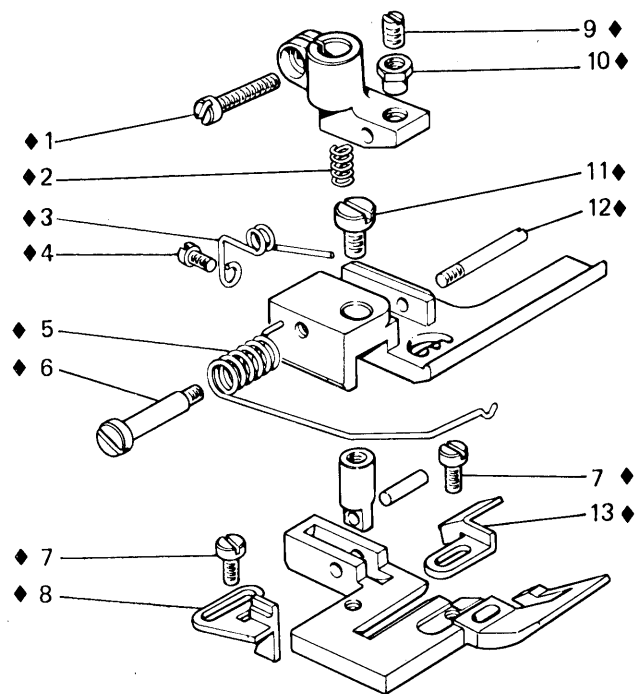
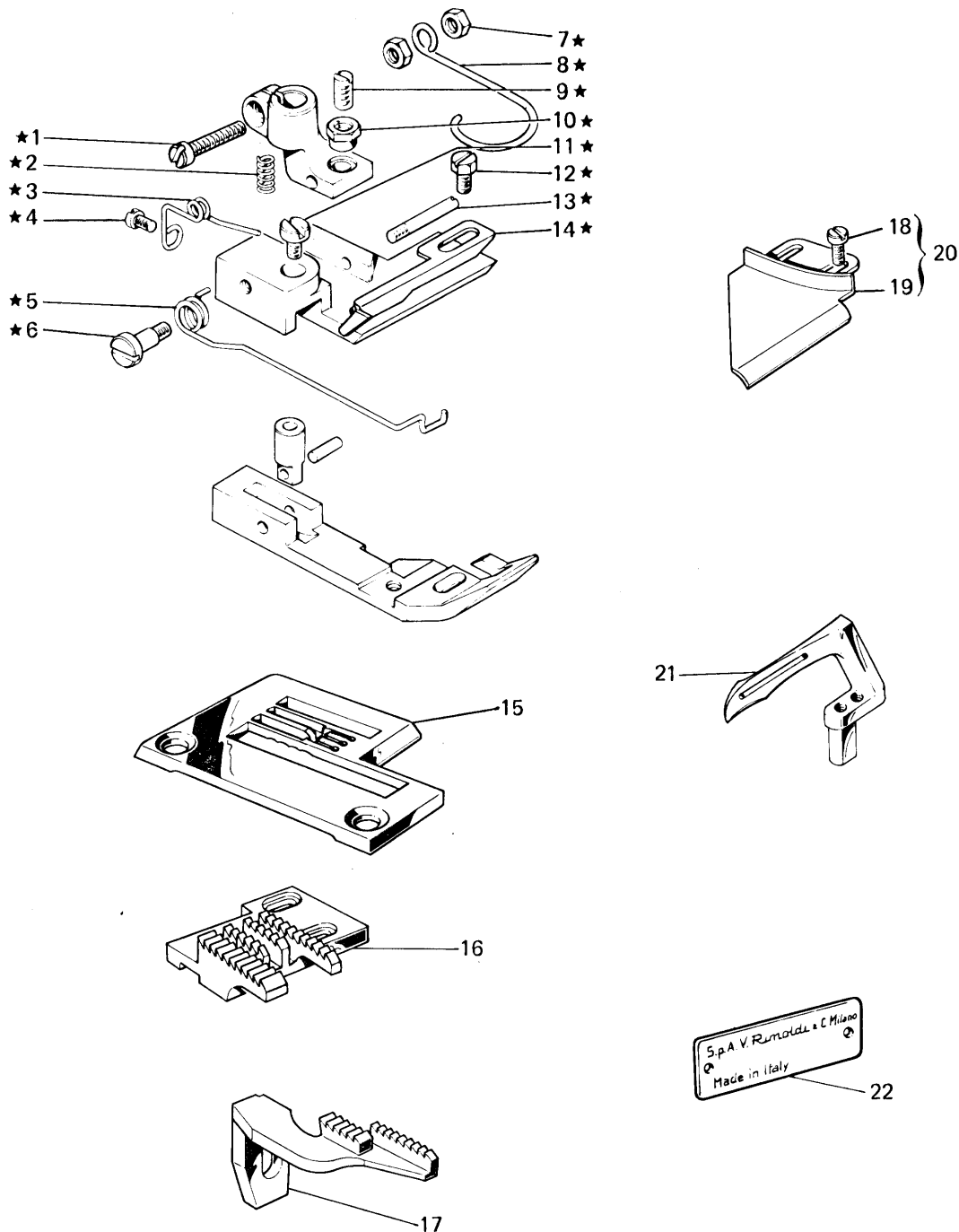

Fig. N. Abb. N.	Part. N. Bestell N. Piece N. Pieza N.	Qt. Anzahl	DESCRIZIONE	DESCRIPTION	DESCRIPTION	BENENNUNG	DESCRIPCION
◆	302882-3-02	1	SOLO A RICHIESTA piedino completo	ONLY ON REQUEST presserfoot assembly	SEULEMENT SUR DEMANDE pied-presseur complet		
★	302765-4-10	1	guida regolabile	control guide	guide réglable		
1	741721-2-00	1	vite	screw	vis		
2	303052-0-00	1	molla	spring	ressort		
3	300119-0-11	1	molla	spring	ressort		
4	721411-2-00	1	vite	screw	vis		
5	302872-0-10	1	molla	spring	ressort		
6	302870-0-10	1	vite	screw	vis		
7	741413-2-00	2	vite	screw	vis		
8	302883-0-00	1	guida pizzo	guide	guide		
9	301596-0-11	1	vite	screw	vis		
10	301598-0-11	1	dado	nut	écrou		
11	741414-2-00	1	vite	screw	vis		
12	300120-0-10	1	spina filettata	pin	pivot		
13	302877-0-00	1	guida elastico	guide	guide		
14	302762-0-10	1	perno	pin	pivot		
15	721474-2-00	1	vite	screw	vis		
16	721494-2-00	1	vite	screw	vis		
17	302768-0-10	1	blocchetto	block	bloc		
18	302766-0-10	1	molla	spring	ressort		
19	302764-2-10	1	guida	guide	guide		
20	746021-2-00	1	dado	nut	écrou		
21	302769-0-10	1	pomolo	knob	pommeau		
22	302767-0-10	1	molla	spring	ressort		
23	302770-0-10	1	pomolo	knob	pommeau		
24	310043-4-00	1	guida regolabile completa	control guide assembly	guide réglable complet		

Fig. N. Abb. N.	Part. N. Bestell N. Piece N. Pieza N.	Qt. Anzahl	DESCRIZIONE	DESCRIPTION	DESCRIPTION	BENENNUNG	DESCRIPCION
45	<u>Tav.4</u> 302842-0-10	1	squadretta	bracket	équerre		
■	309573-4-00	1	SOLO A RICHIESTA gruppo salva ago	ONLY ON REQUEST rear needle guard assembly	SEULEMENT SUR DEMANDE groupe protège-aiguille		
62	305171-0-00	1	salva ago	rear needle guard	protège-aiguille		
	<u>Tav. 10</u>						
▲	309800-4-00	1	morsetto porta aghi completo	needles clamp assembly	porte-aiguille complet		
26	309751-2-00	1	morsetto porta aghi	needles clamp	porte-aiguilles		
27	745810-2-00	3	vite	screw	vis		
28	766000-6-90	3	ago sist.Rim 63 fin.90	needle syst,Rim 63 size 90	aiguille syst.Rim 63 jauge 90		
42	309770-0-00	1	passafilo	thread guide	passe-fil		
	<u>Tav. 14</u>						
★	308531-4-00	1	gruppo tensioni	tensions assembly	groupe tensions		
20	308506-0-00	4	pernetto	pin	pivot		
21	308501-0-01	4	passafilo	thread guide	passe-fil		
22	308503-0-01	4	guidafilo	thread guide	guide-fil		
25	308505-0-00	4	perno a vite	pin	pivot		
26	300218-0-10	8	disco tensione	tension disc	disque tension		
27	308507-0-00	4	rondella	washer	rondelle		
28	202556-0-00	4	scodellino	cup	cuvette		
29	200710-0-10	3	molla	spring	ressort		
30	202229-0-10	4	bussola superiore	upper bush	bague supérieur		
31	202558-2-00	4	pomolo	knob	pommeau		
33	308518-4-00	3	tensione sup.con molla fig.29	upper tension with spring fig.29	tension sup.avec ressort fig.29		



S.p.A. V. Remolada e C. Milano  
 Made in Italy

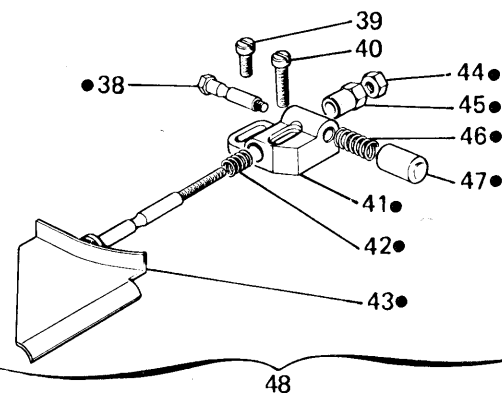
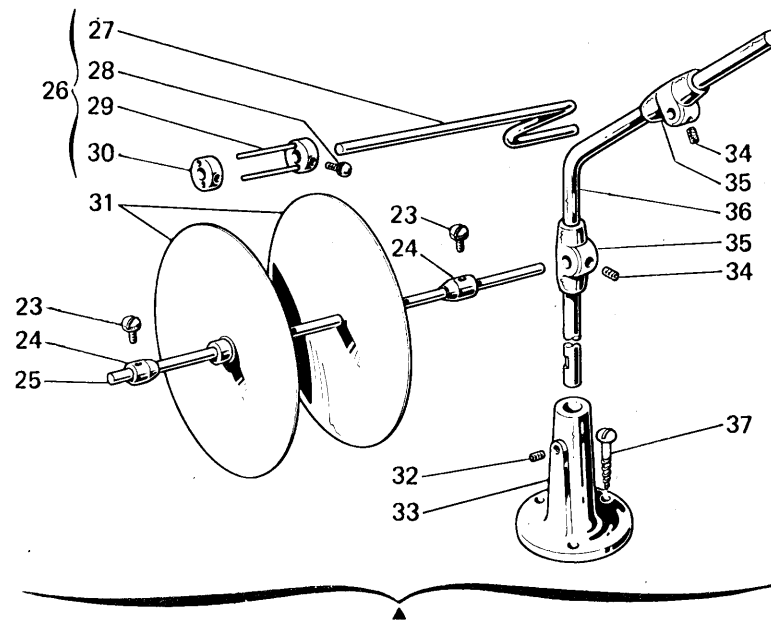
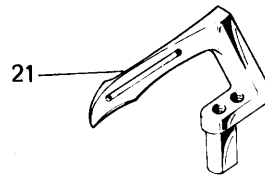
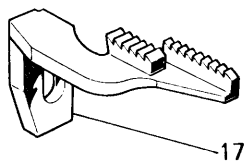
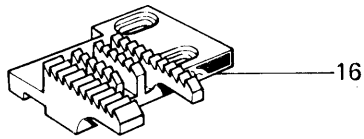
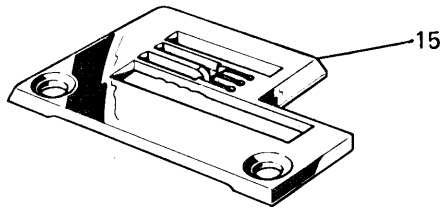
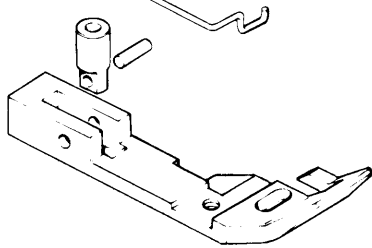
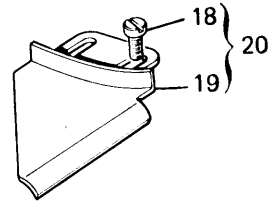
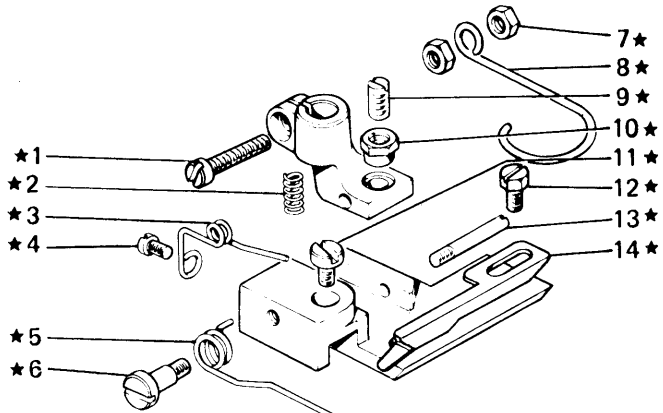

Fig. N. Abb. N.	Part. N. Piecce N. Bestell N. Pieza N.	Ct. Anzahl	DESCRIZIONE	DESCRIPTION	DESCRIPTION	BENENNUNG	DESCRIPCION
★	306680-3-00	1	pedino completo	presserfoot assembly	pied-presseur complet		
▲	991325-4-00	1	porta rotolo	roll carrier	porte-rouleau		
1	741781-2-00	1	vite	screw	vis		
2	303052-0-00	1	molla	spring	ressort		
3	300119-0-11	1	molla	spring	ressort		
4	721411-2-00	1	vite	screw	vis		
5	302821-0-10	1	molla	spring	ressort		
6	743134-2-00	1	vite	screw	vis		
7	733504-2-00	2	dado	nut	écrou		
8	990808-0-01	1	salvadita	protection	protection		
9	301596-0-11	1	vite	screw	vis		
10	301598-0-11	1	dado	nut	écrou		
11	741414-2-00	1	vite	screw	vis		
12	203658-0-10	1	vite	screw	vis		
13	300120-0-10	1	spina filettata	pin	pivot		
14	304411-0-11	1	guida	guide	guide		
15	302774-0-10	1	placca ago	needle plate	plaque aiguille		
16	302795-0-10	1	griffa principale	main feed dog	griffe principale		
17	302797-0-10	1	griffa differenziale	differential feed dog	griffe différentielle		
18	721434-2-00	2	vite	screw	vis		
19	302851-2-10	1	guida	guide	guide		
20	310040-4-00	1	guida con viti	guide with screws	guide avec vis		
21	302057-0-11	1	crochet inferiore	lower looper	crochet inférieur		
22	784300-0-20	1	targhetta classe testa	head cladd plate	plaque classe tête		
23	990596-0-10	2	pomolo	knob	pommeau		
24	990594-2-00	2	anello di registro con pomolo	adjustment ring with knob	anneau de réglage avec pommeau		
25	990593-0-11	1	spina	pin	goupille		
26	990705-4-11	1	passa nastro	strap guide	guide pour bande		
27	990704-0-11	1	spina	pin	goupille		
28	990708-0-10	1	morsetto	clamp	bride		
29	990707-2-10	1	morsetto con spine	clamp with pins	bride avec goupilles		
30	930096-0-10	2	pomolo	knob	pommeau		
31	990612-2-10	2	disco	disc	disque		
32	729054-2-00	1	vite	screw	vis		
33	991114-2-00	1	basetta con vite	base with screw	base avec vis		
34	729024-2-00	4	vite	screw	vis		
35	991153-2-00	2	supporto con viti	support with screws	support avec vis		
36	990703-0-11	1	asta	rod	tige		
37	731107-2-00	3	vite da legno	screw	vis		
			SOLO A RICHIESTA	ONLY ON REQUEST	SEULEMENT SUR DEMANDE		
●	302765-4-10	1	guida regolabile	control guide	guide réglable		
38	302762-0-10	1	perno	pin	pivot		
39	721474-2-00	1	vite	screw	vis		
40	721494-2-00	1	vite	screw	vis		
41	302768-0-10	1	blocchetto	block	bloc		
42	302766-0-10	1	molla	spring	ressort		
43	302764-2-10	1	guida	guide	guide		
44	746021-2-00	1	dado	nut	écrou		



SpA V. Remola e C Milano  
Made in Italy

22

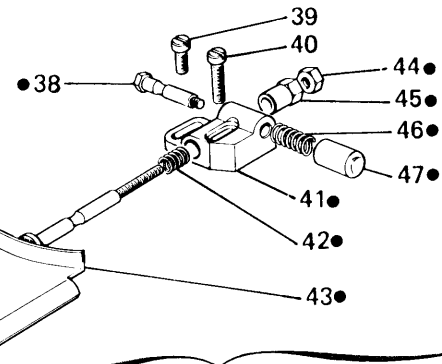
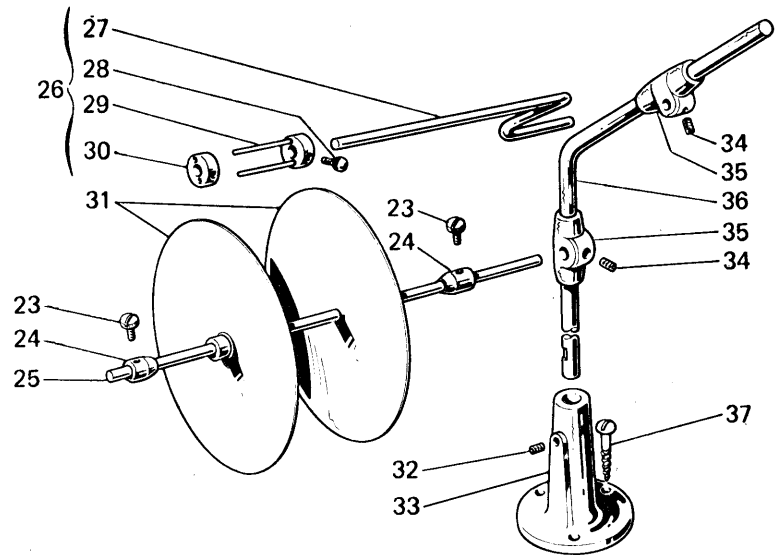

Fig. N. Abb. N.	Part. N. Piece N. Bestell N. Pieza N.	Qt. Anzahl	DESCRIZIONE	DESCRIPTION	DESCRIPTION	BENENNUNG	DESCRIPCION
45	302769-0-10	1	pomolo	knob	pommeau		
46	302767-0-10	1	molla	spring	ressort		
47	302770-0-10	1	pomolo	knob	pommeau		
48	310043-4-00	1	guida regolabile completa	contro guide assembly	guide réglable complet		
45	<u>Tav.4</u> 302842-0-10	1	squadretta	bracket	équerre		
■	309573-4-00	1	SOLO A RICHIESTA gruppo salva ago	ONLY ON REQUEST rear needle guard assembly	SEULEMENT SUR DEMANDE protège aiguille complète		
62	305171-0-00	1	salva ago	rear needle guard	protège-aiguille		
▲	<u>Tav.10</u> 309801-4-00	1	morsetto porta aghi completo	needles clamp assembly	porte-aiguilles complet		
26	309752-2-00	1	morsetto porta aghi	needles clamp	porte-aiguilles		
27	745810-2-00	3	vite	screw	vis		
28	766000-6-90	3	ago sist.Rim 63 fin.90	needle syst.Rim 63 size 90	aiguille syst.Rim 63 jauge 90		
42	309770-0-00	1	passafilo	thread guide	passe-fil		
★	<u>Tav. 14</u> 308531-4-00	1	gruppo tensioni	tensions assembly	groupe tensions		
20	308506-0-00	4	pernetto	pin	pivot		
21	308501-0-01	4	passafilo	thread guide	passe-fil		
22	308503-0-01	4	guida filo	thread guide	guide-fil		
25	308505-0-00	4	perno a vite	pin	pivot		
26	300218-0-10	8	disco tensione	tension disc	disque tension		
27	308507-0-00	4	rondella	washer	rondelle		
28	202556-0-00	4	scodellino	cup	cuvette		
29	200710-0-10	3	molla	spring	ressort		
30	202229-0-10	4	bussola superiore	upper bush	bague supérieur		
31	202558-2-00	4	pomolo	knob	pommeau		
33	308518-4-00	3	tensione sup.con molla fig.29	upper tension with spring fig.29	tension sup.avec ressort fig. 29		

**VARIANTE PER**

**VARIATION FOR**

**VARIANTE POUR**

261-34-2DR-15

261-34-3DR-55



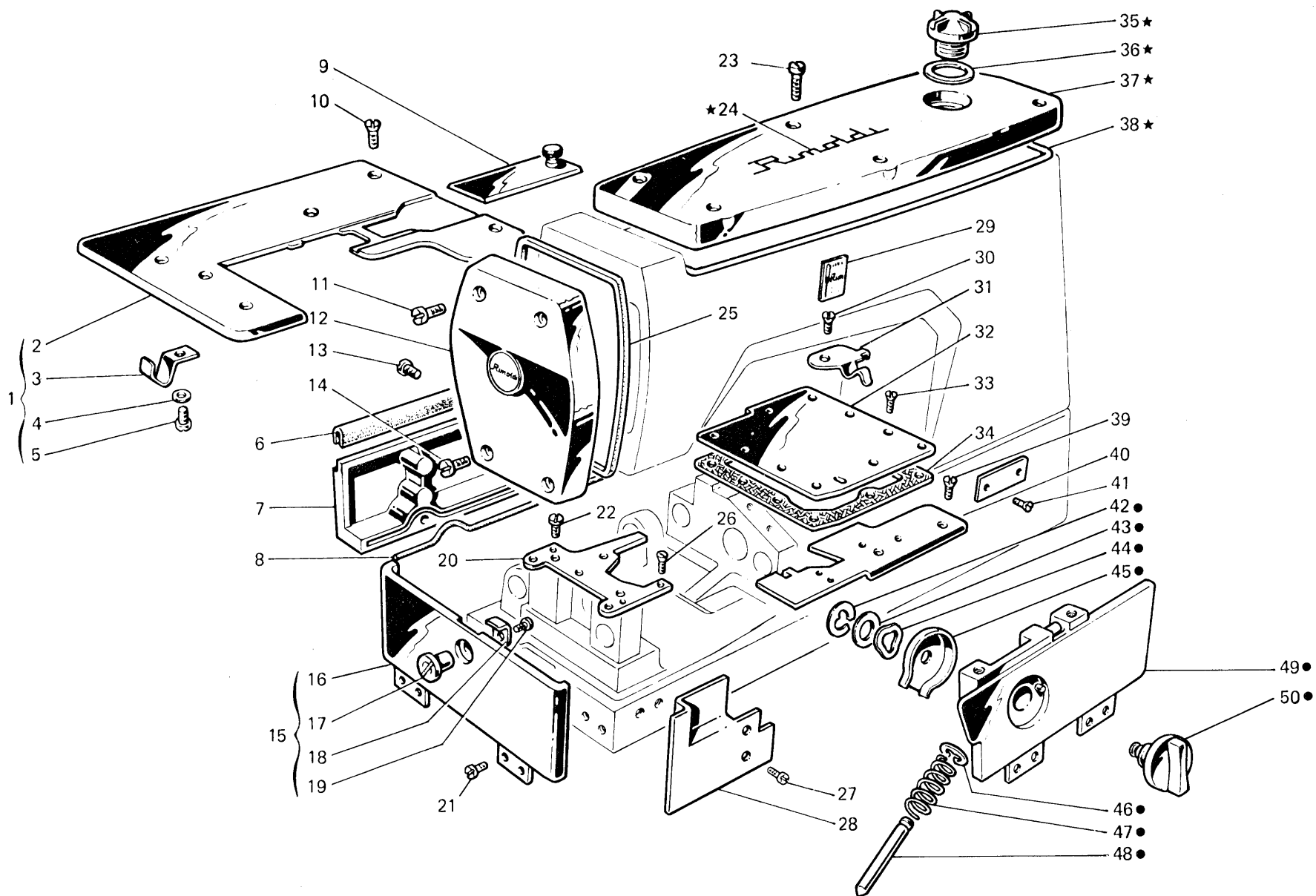

Fig. N. Abb. N.	Part. N. Piecce N. Bestell N. Pieza N.	Qt. Anzahl	DESCRIZIONE	DESCRIPTION	DESCRIPTION	BENENNUNG	DESCRIPCION
★	308103-4-10	1	coperchio superiore completo	upper cover assembly	couvercle supérieur compl.		
●	309213-4-00	1	carter anteriore completo	front cover assembly	carter avant complet		
1	309059-4-00	1	piano di lavoro compl.	working plate assembly	plan de travail complet		
2	309042-2-00	1	piano di lavoro	working plate	plan de travail		
3	309351-0-00	1	molla	spring	ressort		
4	704306-0-00	1	rondella	washer	rondelle		
5	720411-2-00	1	vite	screw	vis		
6	309088-0-00	1	guarnizione	gasket	garniture		
7	309086-0-01	1	carter posteriore	rear cover	carter arrière		
8	309084-0-00	1	guarnizione	gasket	garniture		
9	309302-2-00	1	coperchio scorrevole	sliding cover	couvercle coulissant		
10	744636-2-00	5	vite	screw	vis		
11	302354-0-10	2	vite superiore	upper screw	vis supérieure		
12	308101-2-00	1	coperchio laterale	slide cover	couvercle latéral		
13	741088-2-00	3	vite per carter posteriore	screw for rear cover	vis pour carter arrière		
14	302353-0-10	2	vite inferiore	lower screw	vis inférieur		
15	309139-4-00	1	carter laterale completo	side cover assembly	carter latéral complet		
16	309126-3-00	1	carter laterale	side cover	carter latéral		
17	309372-0-00	1	perno	pin	pivot		
18	309371-0-00	1	chiavistello	key	clé		
19	741658-2-00	1	vite	screw	vis		
20	308783-2-00	1	piastra porta placca	plate	plaque		
21	300483-0-10	8	vite per cerniera	screw for hinge	vis pour charnière		
22	302355-0-10	2	vite per piastra	screw for plate	vis pour plaque		
23	742282-2-00	6	vite per coperchio	screw for cover	vis pour couvercle		
24	300006-0-11	2	decalcomania	decalcomania	décalcomania		
25	308128-0-00	1	guarnizione coperchio	cover gasket	garniture couvercle		
26	744730-0-00	2	vite per placca ago	screw for needle plate	vis pour plaque aiguille		
27	741925-2-00	2	vite	screw	vis		
28	309155-0-00	1	semicarter anteriore sinistro	front left cover	carter avant gauche		
29	788020-0-01	1	decalcomania sistema aghi	needles decalcomania	décalcomanie syst.aiguille		
30	721474-2-00	1	vite	screw	vis		
31	309360-0-00	1	molla chiusura carter	spring	ressort		
32	309324-2-10	1	piastra superiore	upper plate	plaque supérieure		
33	741936-2-00	9	vite per piastra	screw for plate	vis pour plaque		
34	309323-0-00	1	guarnizione	gasket	garniture		
35	202239-0-10	1	cupolina	cup	coupole		
36	705970-0-00	1	guarnizione per cupolina	gasket	garniture		
37	308102-0-00	1	coperchio superiore	upper cover	couvercle supérieur		
38	308129-0-00	1	guarnizione per coperchio	gasket for cover	garniture pour couvercle		
39	744656-2-00	2	vite	screw	vis		
40	309229-0-00	1	piastra piano di lavoro	working plate	plaque plan de travail		
41	202165-0-10	2	vite per targhetta	screw for plate	vis pour plaquette		
42	700208-0-00	1	anello elastico	spring ring	anneau ressort		
43	704314-2-00	1	rondella	washer	rondelle		
44	309326-0-00	1	anello	ring	anneau		
45	309327-0-00	1	coperchio	cover	couvercle		
46	700206-0-00	1	anello elastico	spring ring	anneau ressort		
47	204938-0-10	1	molla	spring	ressort		

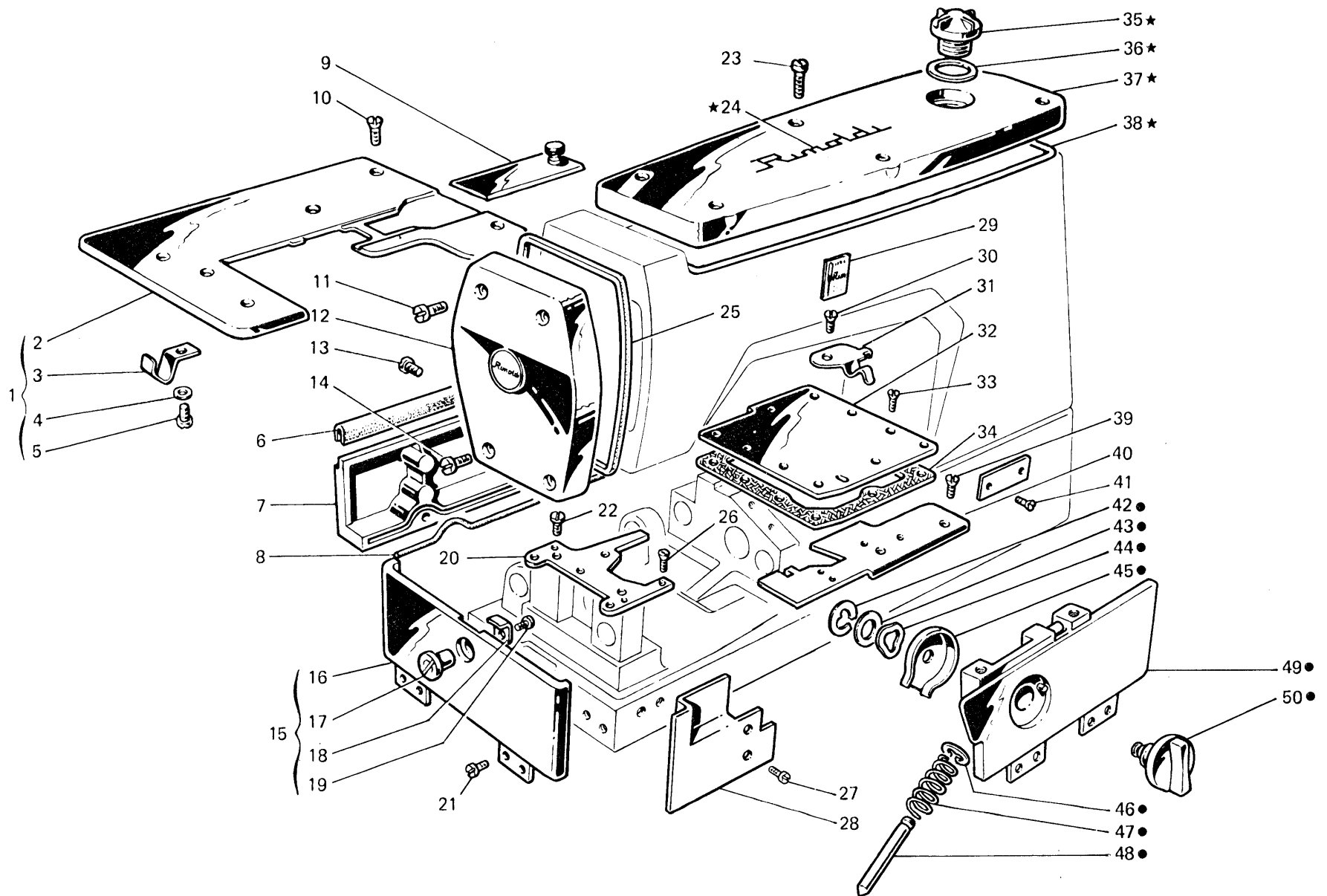

Fig. N. Abb. N.	Part. N. Piec. N. Bestell N. Pieza N.	Ct. Anzahl	DESCRIZIONE	DESCRIPTION	DESCRIPTION	BENENNUNG	DESCRIPCION
48	309328-0-00	1	spina	pin	goupille		
49	309210-3-00	1	carter anteriore	front cover assembly	carter avant complet		
50	309329-0-00	1	manopola	knob	poignée		
40	309231-0-00	1	SOLO A RICHIESTA piastra piano di lavoro	ONLY ON REQUEST plate	SEULEMENT SUR DEMANDE plaque plan de travail		

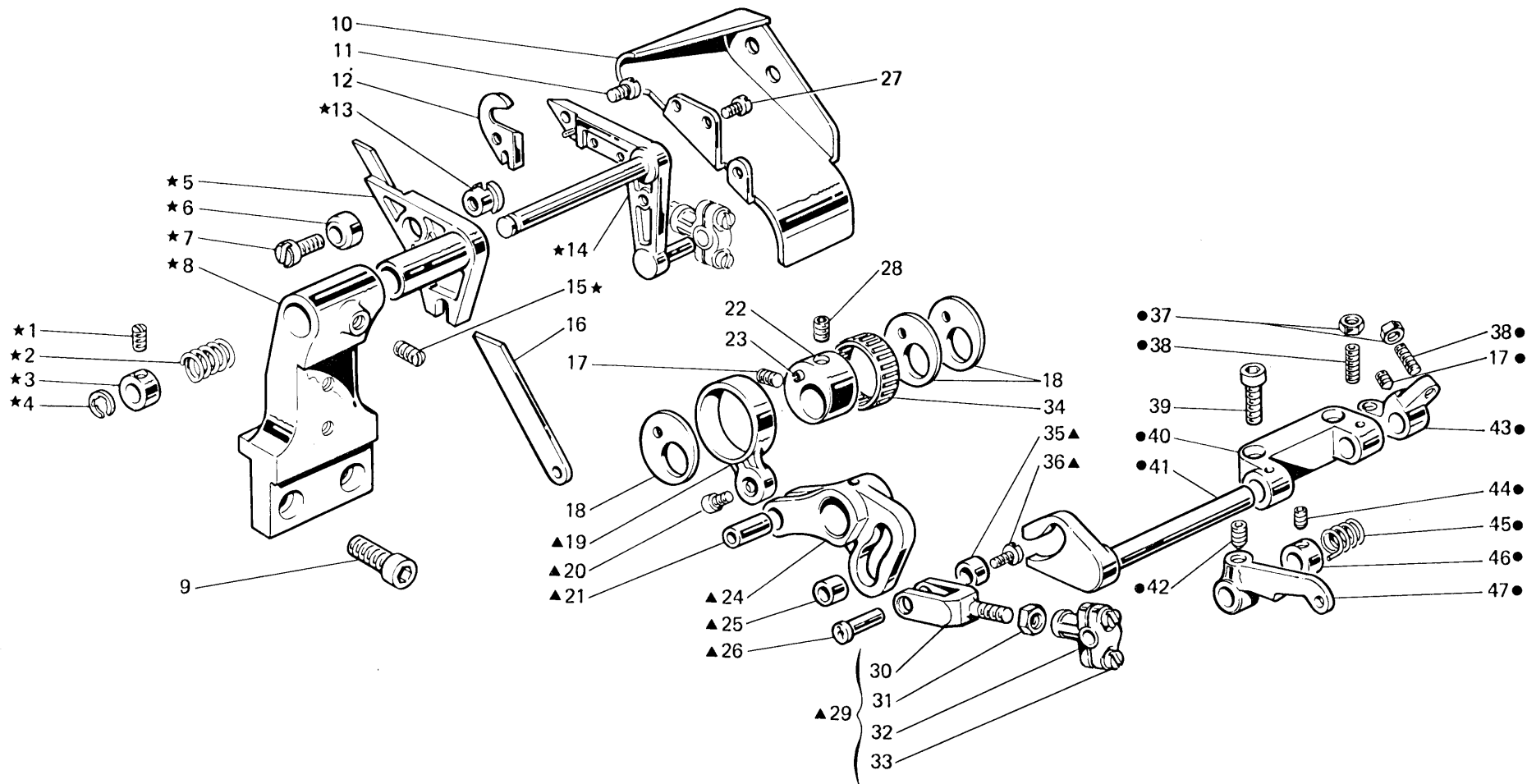

Fig. N. Abb. N.	Part. N. Piece N. Bestell N. Pieza N.	Qt. Anzahl	DESCRIZIONE	DESCRIPTION	DESCRIPTION	BENENNUNG	DESCRIPCION
★	309380-4-01	1	porta coltello completo	knife holder assembly	porte-couteau complet		
▲	303026-4-10	1	comando coltello sup.compl.	upper knife control assembly	commande couteau sup.compl.		
●	303028-4-11	1	supp.disinnesto rifil.compl.	supporto assembly	support complet		
1	745114-0-00	2	vite	screw	vis		
2	302803-0-10	1	molla	spring	ressort		
3	302859-0-10	1	anello	spring	ressort		
4	700210-0-00	1	anello elastico	spring ring	anneau ressort		
5	302804-2-10	1	porta coltello inferiore	lower knife holding	porte-couteau inférieur		
6	302864-0-10	1	scodellino	cup	cuvette		
7	721475-2-00	1	vite	screw	vis		
8	309373-2-00	1	supporto	support	support		
9	722454-2-00	2	vite	screw	vis		
10	303022-0-10	1	carterino	cover	carter		
11	741642-2-00	1	vite	screw	vis		
12	303012-0-10	1	coltello superiore	upper knife	couteau supérieur		
13	302806-0-10	1	anello	ring	anneau		
14	302801-3-11	1	porta coltello superiore	upper knife holding	porte-couteau supérieur		
15	727056-0-00	1	vite	screw	vis		
16	302808-0-10	1	coltello inferiore	lower knife	couteau inférieur		
17	730023-2-00	2	vite	screw	vis		
18	303043-0-10	3	rondella eccentrica	eccentric washer	rondelle excentrique		
19	303013-0-10	1	attacco comando coltello	attachment	raccord		
20	742811-0-00	1	vite	screw	vis		
21	303010-0-10	1	perno	pin	pivot		
22	308763-3-00	1	eccentrico con spina e viti	eccentric with pin and screws	excentrique avec goupille et vis		
23	303042-0-10	1	spina elastica	split pin	goupille réglable		
24	303025-2-10	1	settore	sector	secteur		
25	303031-0-10	1	rullino	roller	rouleau		
26	303048-0-10	1	perno	pin	pivot		
27	721412-2-00	3	vite	screw	vis		
28	729013-2-00	1	vite	screw	vis		
29	303046-4-10	1	biella comando coltello	knif control con-rod	bielle commande couteau		
30	303047-0-10	1	forcella	fork	fourche		
31	746403-2-00	1	dado	nut	écrou		
32	302844-3-10	1	testa di biella con viti	con-rod big end with screws	tête de bielle avec vis		
33	743243-2-00	2	vite	screw	vis		
34	302857-0-10	1	gabbia a rulli	needles cage	cage à aiguilles		
35	303030-0-10	1	rullino	roller	rouleau		
36	741658-2-00	1	vite	screw	vis		
37	746007-2-00	2	dado	nut	écrou		
38	729062-2-00	2	vite	screw	vis		
39	722452-2-00	2	vite	screw	vis		
40	303027-0-10	1	supporto	support	support		
41	303029-0-10	1	leva	lever	levier		
42	729043-2-00	1	vite	screw	vis		
43	303034-0-10	1	blocchetto	block	bloc		
44	745812-2-00	1	vite	screw	vis		
45	303041-0-10	1	molla	spring	ressort		
46	303044-0-10	1	anello	ring	anneau		

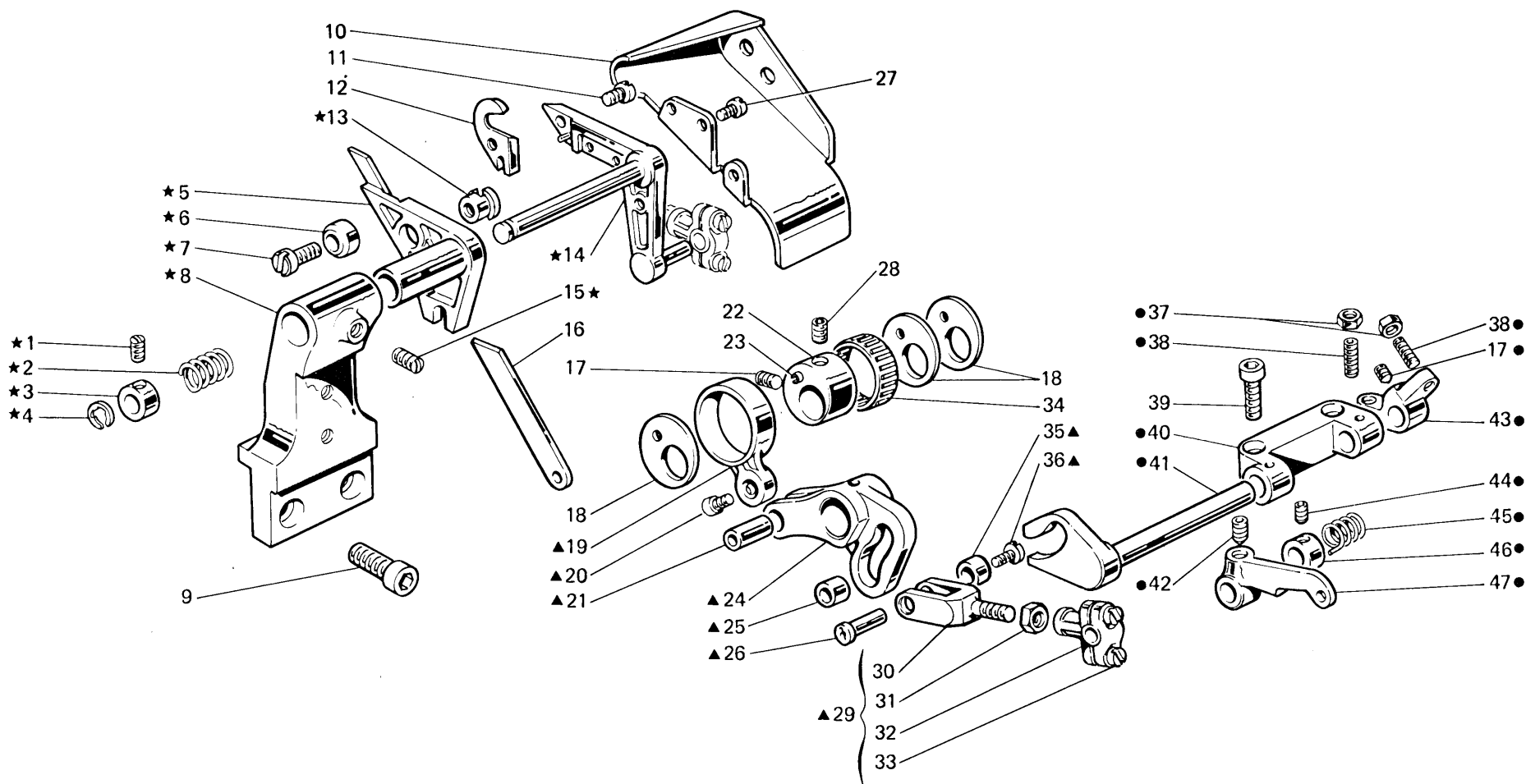

Fig. N. Abb. N.	Part. N. Bestell N. Piece N. Pieza N.	Qt. Anzahl	DESCRIZIONE	DESCRIPTION	DESCRIPTION	BENENNUNG	DESCRIPCION
47	303033-0-11	1	leva	lever	levier		
10	303050-0-10	1	SOLO A RICHIESTA	ONLY ON REQUEST	SEULEMENT SUR DEMANDE		
16	305670-2-00	1	carterino	cover	carter		
			coltello inferiore	lower knife	couteau inférieur		



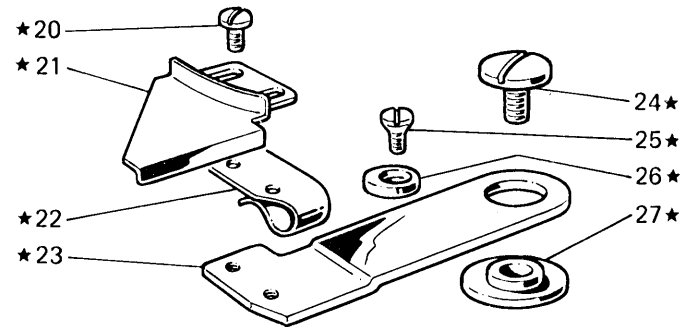
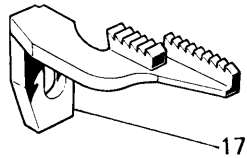
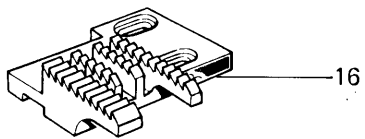
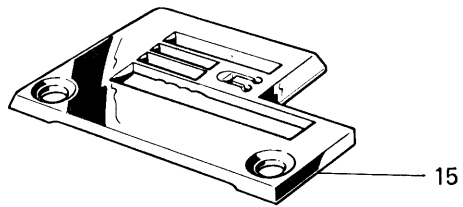
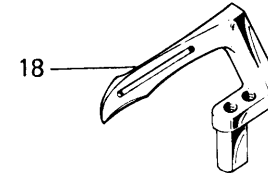
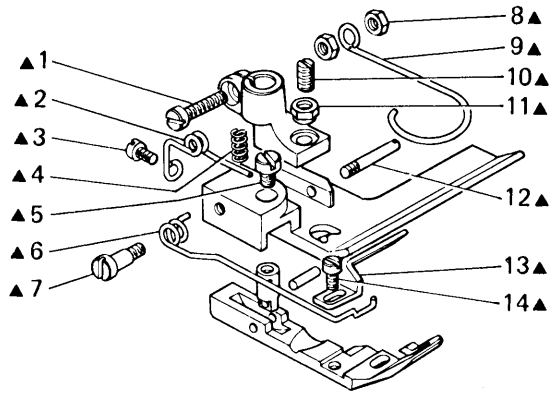

Fig. N. Abb. N.	Part. N. Bestell N. Piece N. Pieza N.	Qt. Anzahl	DESCRIZIONE	DESCRIPTION	DESCRIPTION	BENENNUNG	DESCRIPCION
▲	306679-3-00	1	pedino completo	presserfoot assembly	ped presseur complet		
★	303039-4-11	1	guida completa	guide assembly	guide complet		
1	741781-2-00	1	vite	screw	vis		
2	300119-0-11	1	molla	spring	ressort		
3	721411-2-00	1	vite	screw	vis		
4	303052-0-00	1	molla	spring	ressort		
5	741414-2-00	1	vite	screw	vis		
6	302821-0-10	1	molla	spring	ressort		
7	743134-2-00	1	vite	screw	vis		
8	733504-2-00	2	dado	nut	écrou		
9	990808-0-01	1	salvadita	protection	protection		
10	301596-0-11	1	vite	screw	vis		
11	301598-0-11	1	dado	nut	écrou		
12	300120-0-10	1	spina	pin	goupille		
13	302773-0-11	1	guida	guide	guide		
14	741413-2-00	1	vite	screw	vis		
15	302811-0-10	1	placca ago	needle plate	plaque aiguille		
16	302796-0-10	1	griffa principale	main feed dog	griffe principale		
17	302798-0-10	1	griffa differenziale	differential feed dog	griffe différentielle		
18	302057-0-11	1	crochet inferiore	lower looper	crochet inférieur		
19	784360-0-20	1	targhetta classe testa	head class plate	plaque classe tête		
20	203589-0-10	2	vite	screw	vis		
21	303038-2-10	1	guida	guide	guide		
22	303040-0-11	1	molla	spring	ressort		
23	303037-0-10	1	supporto	support	support		
24	303035-0-10	1	vite	screw	vis		
25	744634-0-00	1	vite	screw	vis		
26	300610-0-10	1	rondella eccentrica	eccentric washer	rondelle excentrique		
27	303036-0-10	1	rondella distanziale	spacer washer	rondelle entretoise		
	<u>Tav. 3</u>		ANNULLATA	CANCELLED	ANNULEE		
	<u>Tav. 13</u>		ANNULLATA	CANCELLED	ANNULEE		

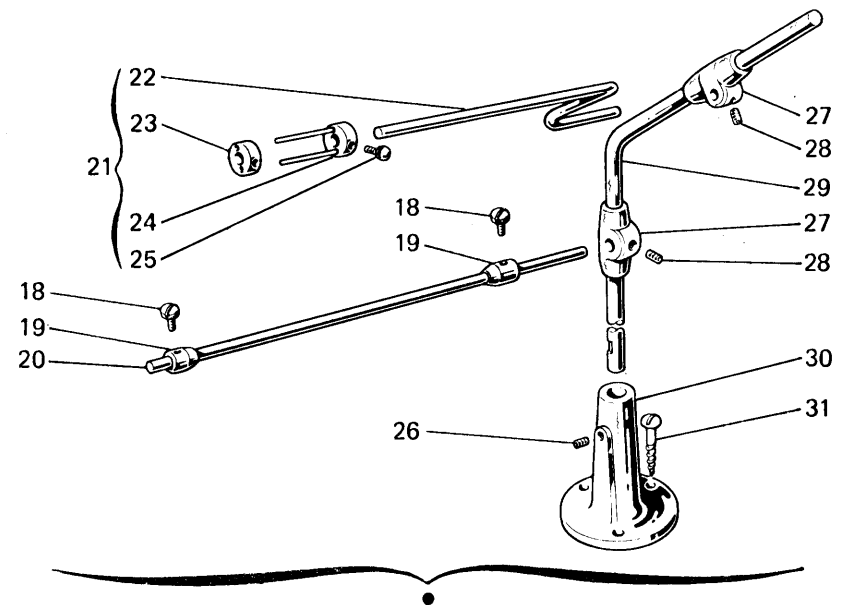
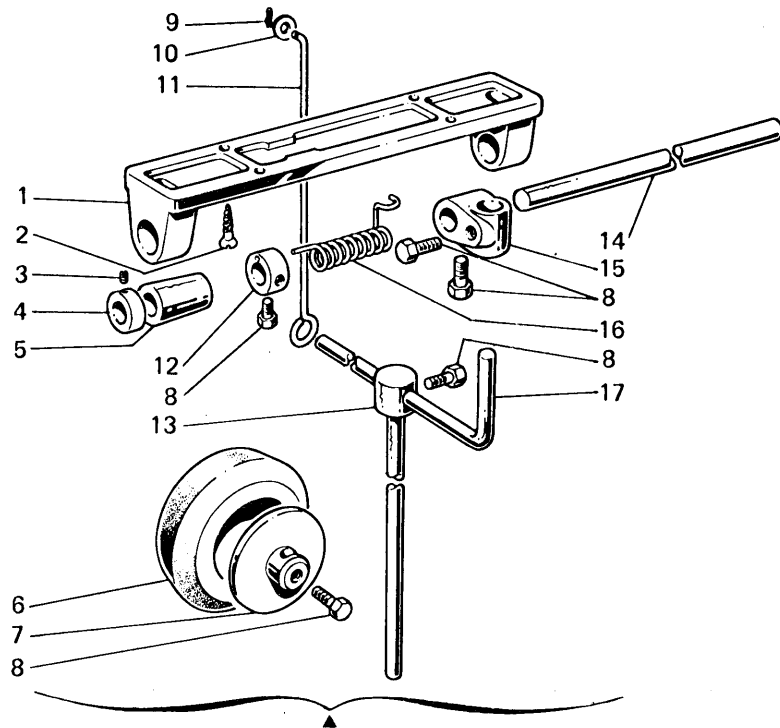
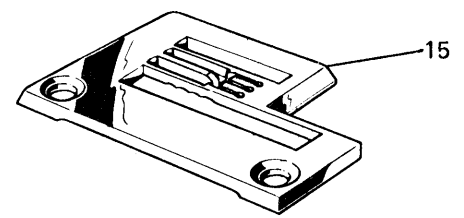
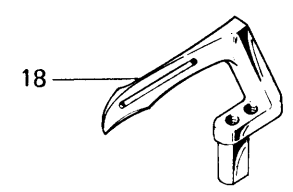
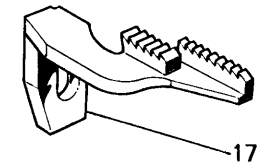
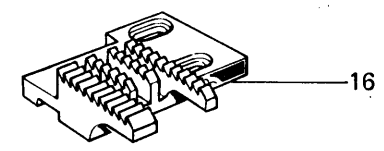
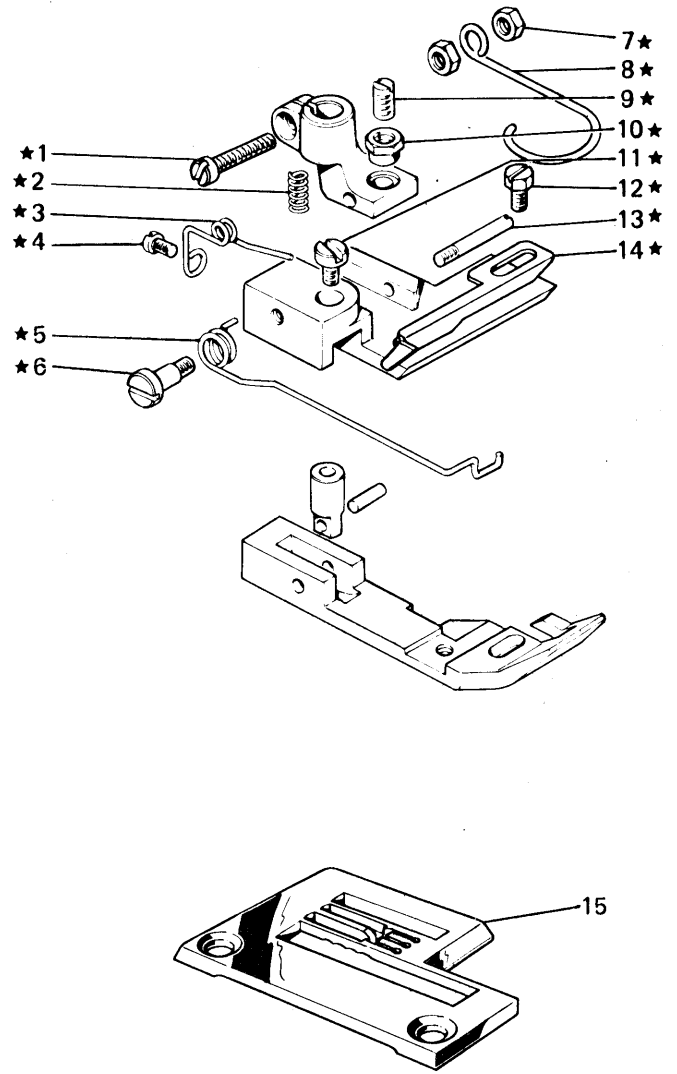

Fig. N. Abb. N.	Part. N. Piece N. Bestell N. Pieza N.	Qt. Anzahl	DESCRIZIONE	DESCRIPTION	DESCRIPTION	BENENNUNG	DESCRIPCION
●	990709-4-12	1	porta rotolo completo	roll carrier assembly	porte-rouleau complet		
▲	920083-4-00	1	ginocchiello completo	knee press assembly	genouillère compl.		
1	920090-0-00	1	supporto	support	support		
2	731306-0-00	4	vite da legno	screw	vis		
3	729013-2-00	2	vite	screw	vis		
4	920242-2-00	2	anello con viti	ring with screws	anneau avec vis		
5	920231-0-00	2	bussola	bush	bague		
6	920113-0-10	1	cuscino	pad	coussin		
7	920105-0-10	1	disco	disc	disque		
8	740035-0-00	6	vite	screw	vis		
9	702032-0-00	1	copiglia	split pin	goupille		
10	704206-0-00	1	rondella	washer	rondelle		
11	920190-0-10	1	tirante	tie-rod	tirant		
12	920114-0-10	1	anello	ring	anneau		
13	920150-0-10	1	asta	rod	tige		
14	920230-0-00	1	albero	shaft	arbre		
15	920183-0-10	1	attacco	raccord	raccord		
16	920106-0-10	1	molla	spring	ressort		
17	920192-0-10	1	leva	lever	levier		
18	990596-0-10	2	pomolo	knob	pommeau		
19	990594-2-00	2	anello di registro con pomolo	adjustment ring with knob	anneau de réglage avec pommeau		
20	990593-0-11	1	spina	pin	goupille		
21	990705-4-11	1	passa nastro	strap guide	guide pour bande		
22	990704-0-11	1	spina	pin	goupille		
23	990708-0-10	1	morsetto	clamp	bride		
24	990707-2-10	1	morsetto con spina	clamp with pin	bride avec goupille		
25	930096-0-10	2	pomolo	knob	pommeau		
26	729054-2-00	1	vite	screw	vis		
27	991153-2-00	2	supporto con viti	support with screws	support avec vis		
28	729024-2-00	4	vite	screw	vis		
29	990703-0-11	1	asta	rod	tige		
30	991114-2-00	1	basetta con vite	base with screw	base avec vis		
31	731107-2-00	3	vite da legno	screw	vis		



S.p.A. V. Remolida e C. Milano  
 Made in Italy

Fig. N. Abb. N.	Part. N. Bestell N. Piece N. Pieza N.	Qt. Anzahl	DESCRIZIONE	DESCRIPTION	DESCRIPTION	BENENNUNG	DESCRIPCION
★	306678-3-00	1	pedino completo	presserfoot assembly	pied-presseur complet		
1	741781-2-00	1	vite	screw	vis		
2	303052-0-00	1	molla	spring	ressort		
3	300119-0-11	1	molla	spring	ressort		
4	721411-2-00	1	vite	screw	vis		
5	302821-0-10	1	molla	spring	ring		
6	743134-2-00	1	vite	screw	vis		
7	733504-2-00	2	dado	nut	écrou		
8	990808-0-01	1	salvadita	protection	protection		
9	301596-0-11	1	vite	screw	vis		
10	301598-0-11	1	dado	nut	écrou		
11	741414-2-00	1	vite	screw	vis		
12	203658-0-10	1	vite	screw	vis		
13	300120-0-10	1	spina filettata	pin	goupille		
14	304411-0-11	1	guida	guide	guide		
15	302735-0-10	1	placca ago	needle plate	plaque aiguille		
16	302795-0-10	1	griffa principale	main feed dog	griffe principale		
17	302797-0-10	1	griffa differenziale	differential feed dog	griffe différentielle		
18	302057-0-11	1	crochet inferiore	lower looper	crochet inférieur		
19	784300-0-20	1	targhetta classe testa	head class plate	plaque classe tête		

TAV. 27

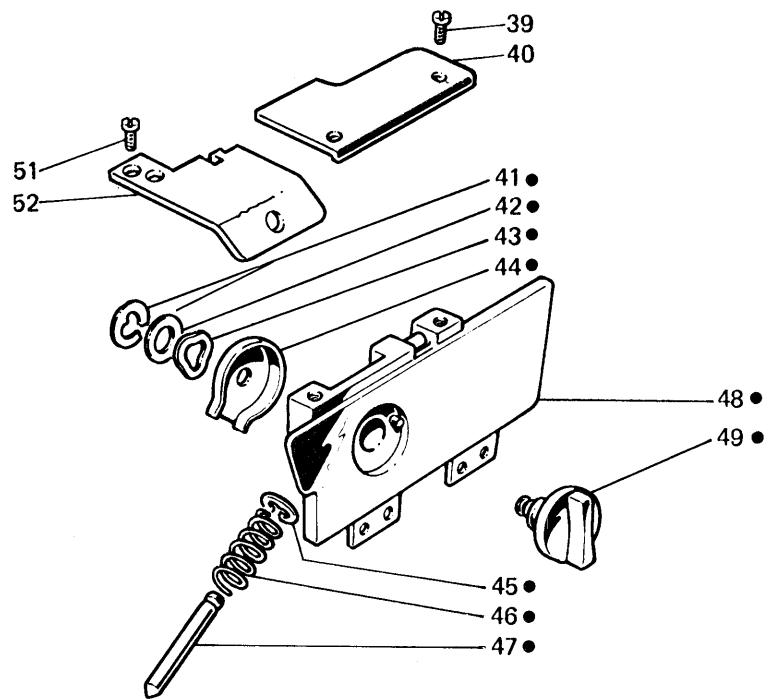

Fig. N. Abb. N.	Part. N. Piece N. Bestell N. Pieza N.	Qt. Anzahl	DESCRIZIONE	DESCRIPTION	DESCRIPTION	BENENNUNG	DESCRIPCION
45	<u>Tav. 4</u> 302842-0-10	1	squadretta	bracket	équerre		
■	309573-4-00	1	SOLO A RICHIESTA	ONLY ON REQUEST	SEULEMENT SUR DEMANDE		
62	305171-0-00	1	gruppo salva ago	rear needle guard assembly	groupe protège-aiguille		
			salva ago	rear needle guard	protège-aiguille		
	<u>Tav.10</u>						
▲	309800-4-00	1	morsetto porta aghi compl.	needles clamp assembly	porte-aiguilles complet		
26	309751-2-00	1	morsetto porta aghi	needles clamp	porte-aiguilles		
27	745810-2-00	3	vite	screw	vis		
28	766000-6-80	3	ago sist.Rim.63 fin.80	needle syst.Rim63 size 80	aiguille syst.Rim 63 jauge 80		
42	309770-0-00	1	passafilo	thread guide	passe-fil		
	<u>Tav.14</u>						
★	308531-4-00	1	gruppo tensioni	tensions assembly	groupe tensions		
20	308506-0-00	4	pernetto	pin	pivot		
21	308501-0-01	4	passafilo	thread guide	passe-fil		
22	308503-0-01	4	guidafilo	thread guide	guide-fil		
25	308505-0-00	4	perno a vite	pin	pivot		
26	300218-0-10	8	disco tensione	tension disc	disque tension		
27	308507-0-00	4	rondella	washer	rondelle		
28	202556-0-00	4	scodellino	cup	cuvette		
29	200710-0-10	3	molla	spring	ressort		
30	202229-0-10	4	bussola superiore	upper bush	bague supérieure		
31	202558-2-00	4	pomolo	knob	pommeau		
33	308518-4-00	3	tensione sup.con molla fig.29	upper tension with spring fig.29	tension sup.avec ressort fig.29		
	<u>Tav. 27</u>						
●	309214-4-00	1	carter anteriore completo	front cover assembly	carter avant complet		
1	309063-4-00	1	piano di lavoro completo	working plate assembly	plan de travail complet		
2	309046-2-00	1	piano di lavoro	working plate	plan de travail		
40	309275-0-00	1	piastra piano di lavoro	plate	plaque		
49	309211-3-00	1	carter anteriore	front cover	carter avant		
51	744654-2-00	2	vite	screw	vis		
52	309276-0-00	1	piastra piano di lavoro	plate	plaque		