

Rumoldu

CATALOGO PEZZI DI RICAMBIO
SPARE PARTS CATALOGUE
CATALOGUE RECHANGES
ERSATZTEILELISTE

APPARECCHIATURE
ATTACHMENTS
DISPOSITIFS
VORRICHTUNGEN

551-11 551-41

n. 128

652090310

APPARECCHIATURA ATTACHMENT DISPOSITIF VORRICHTUNG

551-11

PER TESTE	171-10-2MD-01
FOR HEADS	171-10-2MD-03
POUR TETES	171-11-2MD-02
FÜR OBERTEILE	171-11-3MD-01
	171-34-3MD-02

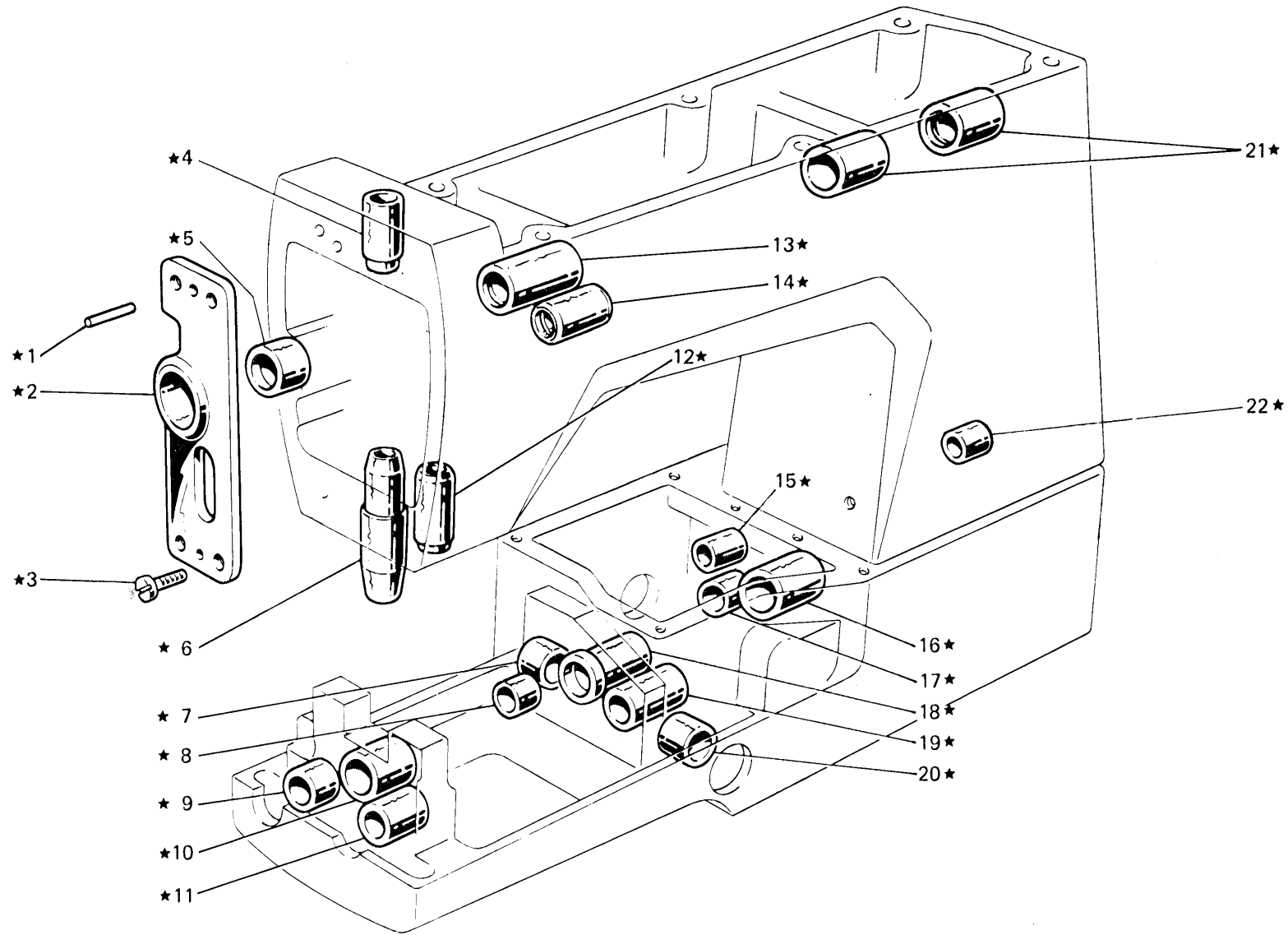

Fig. N. Abb. N.	Part. N. Bestell N. Piece N. Pieza N.	Qt. Anzahl	DESCRIZIONE	DESCRIPTION	DESCRIPTION	BENENNUNG	DESCRIPCION
★	924377-3-00	1	base e braccio con bussole	base and arm with bushes	base et bras avec bagues		
1	706454-0-00	2	spina	pin	goupille		
2	308859-2-00	1	supporto con bussola fig. 5	support with bush fig. 5	support avec bague fig.5		
3	721485-2-00	4	vite	screw	vis		
4	308032-0-00	1	bussola	bush	bague		
5	308858-0-00	1	bussola	bush	bague		
6	308406-0-00	1	bussola	bush	bague		
7	311007-0-00	1	bussola	bush	bague		
8	311180-0-00	1	bussola	bush	bague		
9	311168-0-00	1	bussola	bush	bague		
10	311003-0-00	1	bussola	bush	bague		
11	311008-0-00	1	bussola	bush	bague		
12	308031-0-00	1	bussola	bush	bague		
13	308852-0-00	1	bussola	bush	bague		
14	308232-0-00	1	bussola	bush	bague		
15	311116-0-00	1	bussola	bush	bague		
16	308086-0-00	1	bussola	bush	bague		
17	311009-0-00	1	bussola	bush	bague		
18	311004-0-10	1	bussola	bush	bague		
19	308298-0-00	1	bussola	bush	bague		
20	311006-0-00	1	bussola	bush	bague		
21	308853-0-00	2	bussola	bush	bague		
22	311167-0-00	1	bussola	bush	bague		

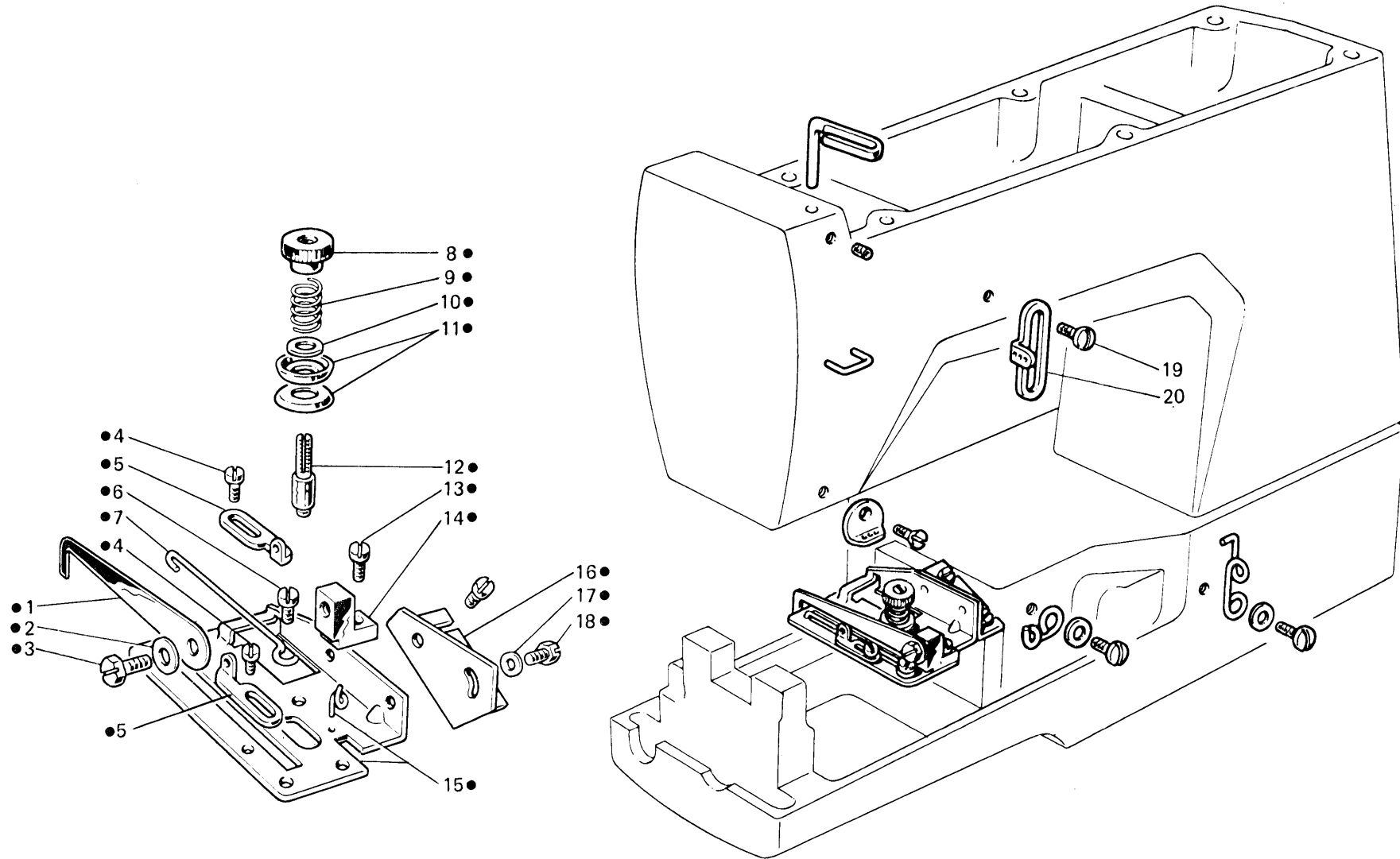

Fig. N. Abb. N.	Part. N. Bestell N. Pieze N.	Qt. Anzahl	DESCRIZIONE	DESCRIPTION	DESCRIPTION	BENENNUNG	DESCRIPCION
●	924394-4-00	1	gruppo tensione crochet inf.	lower looper tension ass.	groupe tensions crochet inf.		
1	308556-0-00	1	astina	rod	tige		
2	705201-0-00	1	rondella	washer	rondelle		
3	740220-2-00	1	vite	screw	vis		
4	741413-2-00	2	vite	screw	vis		
5	302172-0-10	2	passafilo	thread guide	passe-fil		
6	741612-0-00	1	vite	screw	vis		
7	308558-0-00	1	traversino	tie	traverse		
8	302204-0-10	1	pomolo	knob	pommeau		
9	300310-0-10	1	molla	spring	ressort		
10	704218-2-00	1	rondella	washer	rondelle		
11	200324-0-10	2	disco tensione	tension disc	disque tension		
12	300391-0-10	1	perno a vite	threaded pin	pivot à vis		
13	741642-2-00	1	vite	screw	vis		
14	302168-2-10	1	supporto	support	support		
15	924395-2-00	1	piastra	plate	plaque		
16	311188-0-00	1	squadretta	bracket	équerre		
17	704302-4-00	2	rondella	washer	rondelle		
18	740210-2-00	2	vite	screw	vis		
19	303045-0-10	1	vite	screw	vis		
20	308203-0-01	1	guidafilo	thread guide	guide-fil		

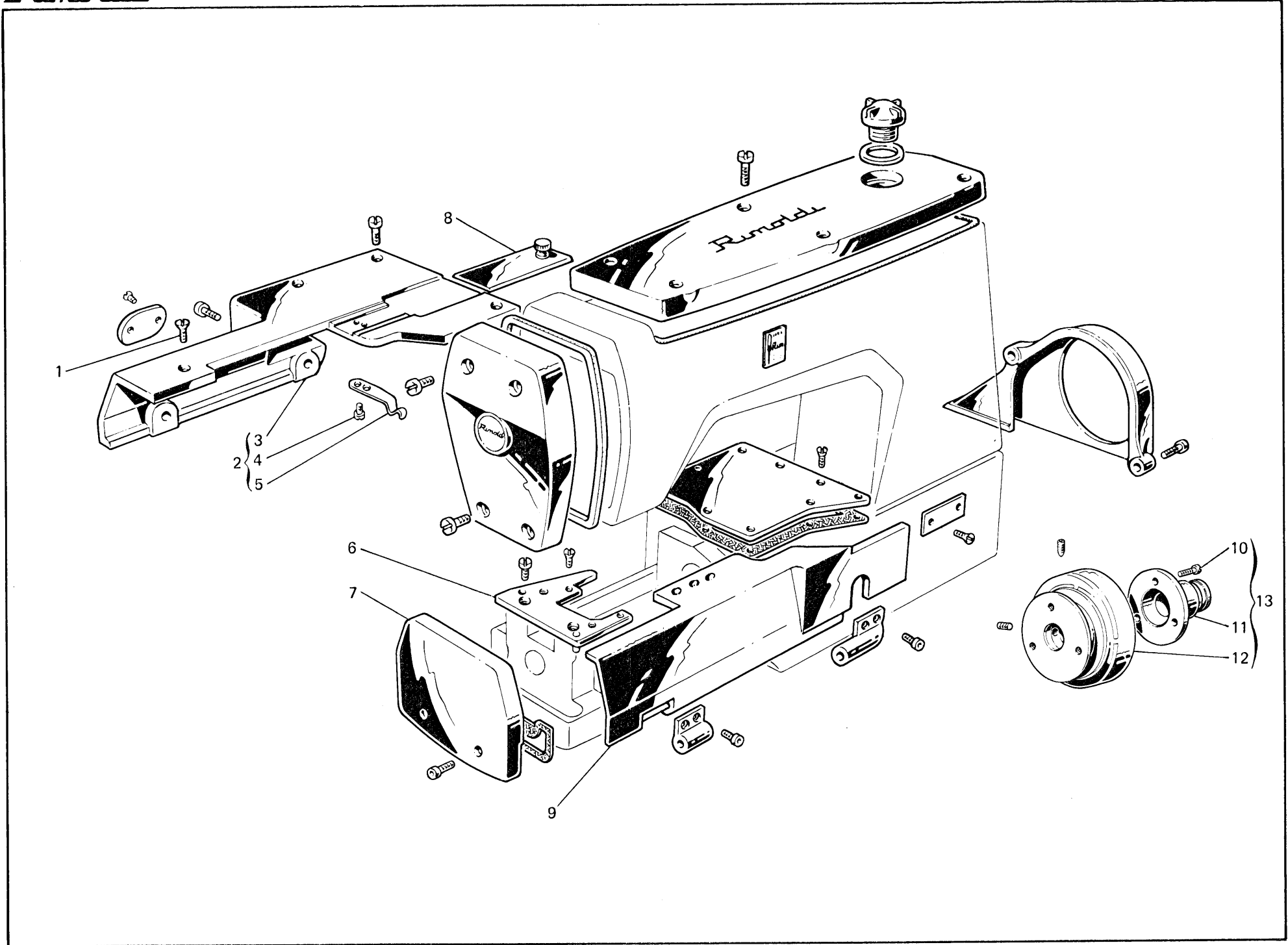

Fig. N. Abb. N.	Part. N. Bestell N. Piece N. Pieza N.	Qt. Anzahl	DESCRIZIONE	DESCRIPTION	DESCRIPTION	BENENNUNG	DESCRIPCION
1	744636-2-00	1	vite	screw	vis		
2	924403-3-00	1	piano lavoro completo	working plate assembly	plan de travail complet		
3	924386-0-00	1	piano di lavoro	working plate	plan de travail		
4	742812-2-00	2	vite	screw	vis		
5	311242-0-00	1	molla	spring	ressort		
7	924474-0-00	1	carter laterale	side cover	carter latéral		
8	309312-2-00	1	coperchio scorrevole	sliding cover	couvercle coulissant		
9	311258-3-00	1	carter anteriore completo	front cover assembly	carter avant complet		
10	741974-2-00	3	vite	screw	vis		
11	302247-0-10	1	flangia	flange	flasque		
12	924365-0-00	1	volantino	handwheel	volant		
13	924405-4-00	1	volantino con flangia	handwheel with flange	volant avec flasque		
			VARIANTE PER	VARIATION FOR	VARIANTE POUR		
				171-11-2MD-02 171-11-3MD-01			
2	924404-3-00	1	piano di lavoro completo	workign plate assembly	plan de travail complet		
3	924467-0-00	1	piano di lavoro	working plate	plan de travail		
			VARIANTE PER	VARIATION FOR	VARIANTE POUR		
				171-34-3MD-02			
9	924398-3-00	1	carter anteriore completo	front cover assembly	carter avant complet		
			PEZZI ANNULLATI	CANCELLED PARTS	PIECES ANNULEES		
6	311226-2-00	1	piastra porta placca	plate	plaque		

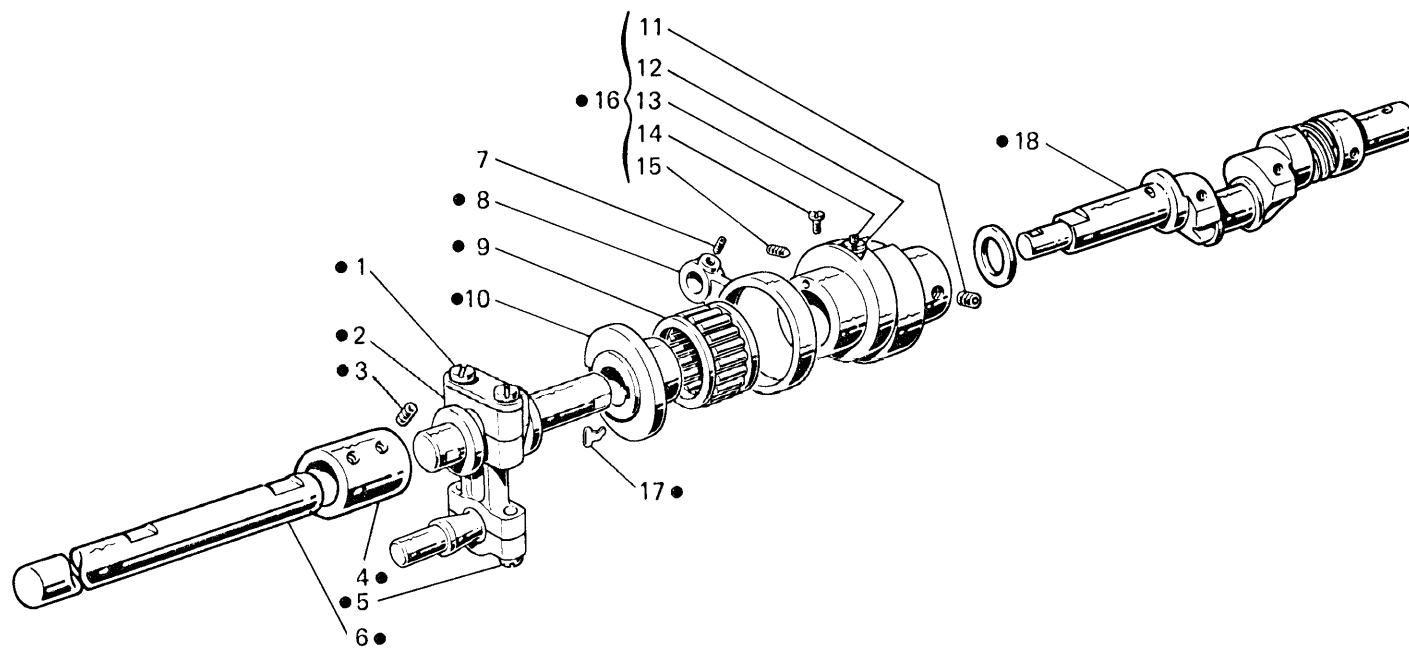

Fig. N. Abb. N.	Part. N. Piecce N. Bestell N. Pieza N.	Qt. Anzahl	DESCRIZIONE	DESCRIPTION	DESCRIPTION	BENENNUNG	DESCRIPCION
●	311364-4-00	1	gruppo albero inferiore	lower shaft assembly	groupe arbre inférieur		
1	311021-0-00	2	vite per biella	screw for con-rod	vis pour bielle		
2	311030-3-10	1	biella completa con viti	con rod assembly with screws	bielle compl.avec vis		
3	745827-2-00	4	vite	screw	vis		
4	311014-0-00	1	manicotto	coupling	manchon		
5	308802-0-00	2	vite per biella	screw for con-rod	vis pour bielle		
6	311088-2-10	1	semialbero inferiore sinistro	left lower half-shaft	semi-arbre inférieur gauche		
7	745811-2-00	1	vite	screw	vis		
8	311105-0-00	1	biella comando trasporto	transport control con-rod	beille commande crochet		
9	311186-0-00	1	gabbia a rullini	needle cage	cage à aiguille		
10	311022-0-00	1	eccentrico spostamento	eccentric	excentrique		
11	729024-2-00	4	vite	screw	vis		
12	206603-0-10	1	fermo per eccentrico	eccentric retainer	pièce pour excentrique		
13	729051-2-00	1	vite per fermo	screw	vis		
14	202473-0-10	2	vite	screw	vis		
15	202472-0-10	2	vite	screw	vis		
16	311015-4-01	1	eccentrico regolabile trasporto	eccentric	excentrique		
17	206872-0-00	1	molla	spring	ressort		
18	311190-3-01	1	semilabero inferiore destro	right lower half-shaft	semi-arbre inférieur droite		

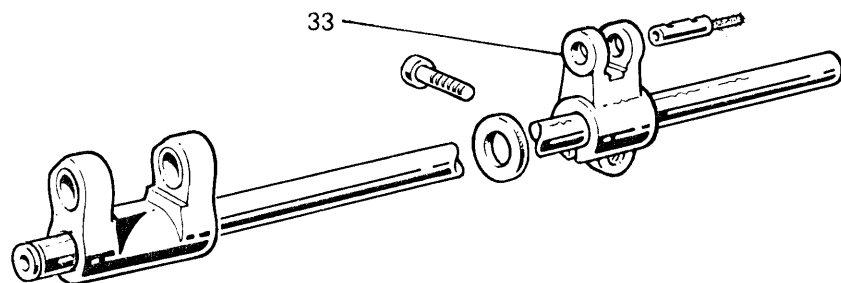
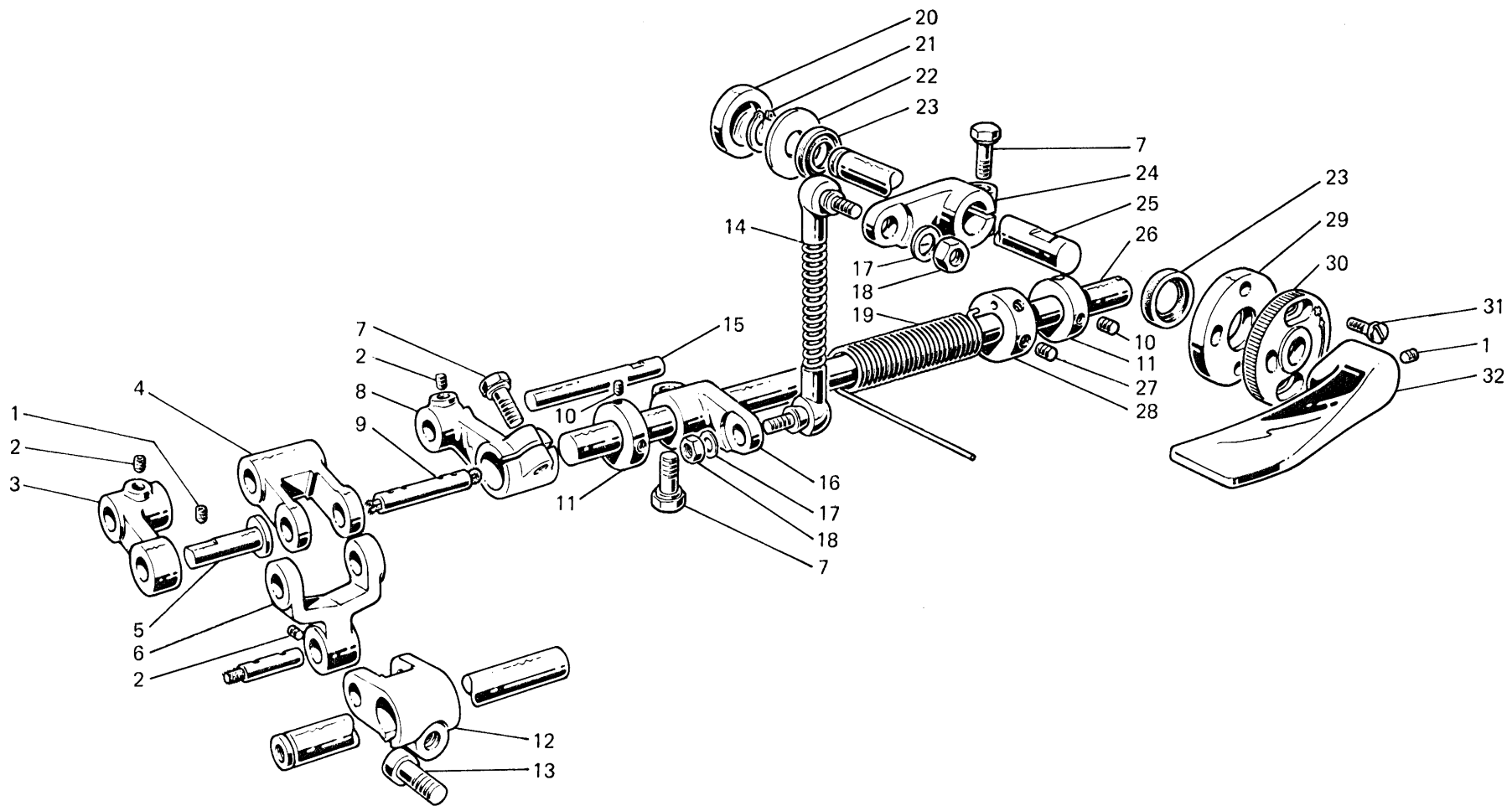

Fig. N. Abb. N.	Part. N. Piece N. Bestell N. Pieza N.	Qt. Anzahl	DESCRIZIONE	DESCRIPTION	DESCRIPTION	BENENNUNG	DESCRIPCION
1	729013-2-00	3	vite	screw	vis		
2	745811-2-00	3	vite	screw	vis		
3	311113-2-00	1	braccio con vite	arm with screw	bras avec vis		
4	311108-0-00	1	braccio oscillante	arm	bras		
5	311117-0-00	1	perno	pin	pivot		
6	311107-2-00	1	giunto con vite	joint with screw	joint avec vis		
7	202502-0-10	3	vite	screw	vis		
8	311112-2-00	1	braccio con vite	arm with screw	bras avec vis		
9	311250-2-00	1	perno con stoppini	pin with wicks	pivot avec mèches		
10	745812-2-00	4	vite	screw	vis		
11	206606-2-00	2	anello di registro con viti	adjustment ring with screws	bague d'étanchéité avec vis		
12	311110-2-00	1	braccio a forcella con vite	fork arm with screw	bras à fourche avec vis		
13	744332-2-00	1	vite	screw	vis		
14	311300-3-00	1	gruppo tirante	tie-rod assembly	groupe tirant		
15	311114-0-00	1	perno	pin	pivot		
16	311131-2-00	1	braccio con vite	arm with screw	bras avec vis		
17	704309-4-00	2	rondella	washer	rondelle		
18	746020-2-00	2	dado	nut	écrou		
19	311133-0-00	1	molla	spring	ressort		
20	311036-0-00	1	tappo	plug	bouchon		
21	700010-0-00	1	anello di fermo	spring ring	anneau ressort		
22	704240-2-00	1	rondella	washer	rondelle		
23	304763-0-10	2	anello di tenuta	retainer ring	bague d'étanchéité		
24	311135-2-00	1	braccio con vite	arm with screw	bras avec vis		
25	311128-0-00	1	perno	pin	pivot		
26	311115-0-00	1	albero	shaft	arbre		
27	729012-2-00	2	vite	screw	vis		
28	311134-2-00	1	anello con viti	ring with screws	anneau avec vis		
29	311132-0-00	1	flangia	flange	flasque		
30	311127-0-00	1	flangia limitatrice	flange	flasque		
31	741056-0-00	2	vite	screw	vis		
32	311126-2-00	1	tasto con viti	push-button with screws	touche avec vis		
33	311053-2-00	1	PEZZI ANNULLATI braccio forcella con vite	CANCELLED PARTS fork arm with screws	PIECES ANNULLEES bras fourche avec vis		

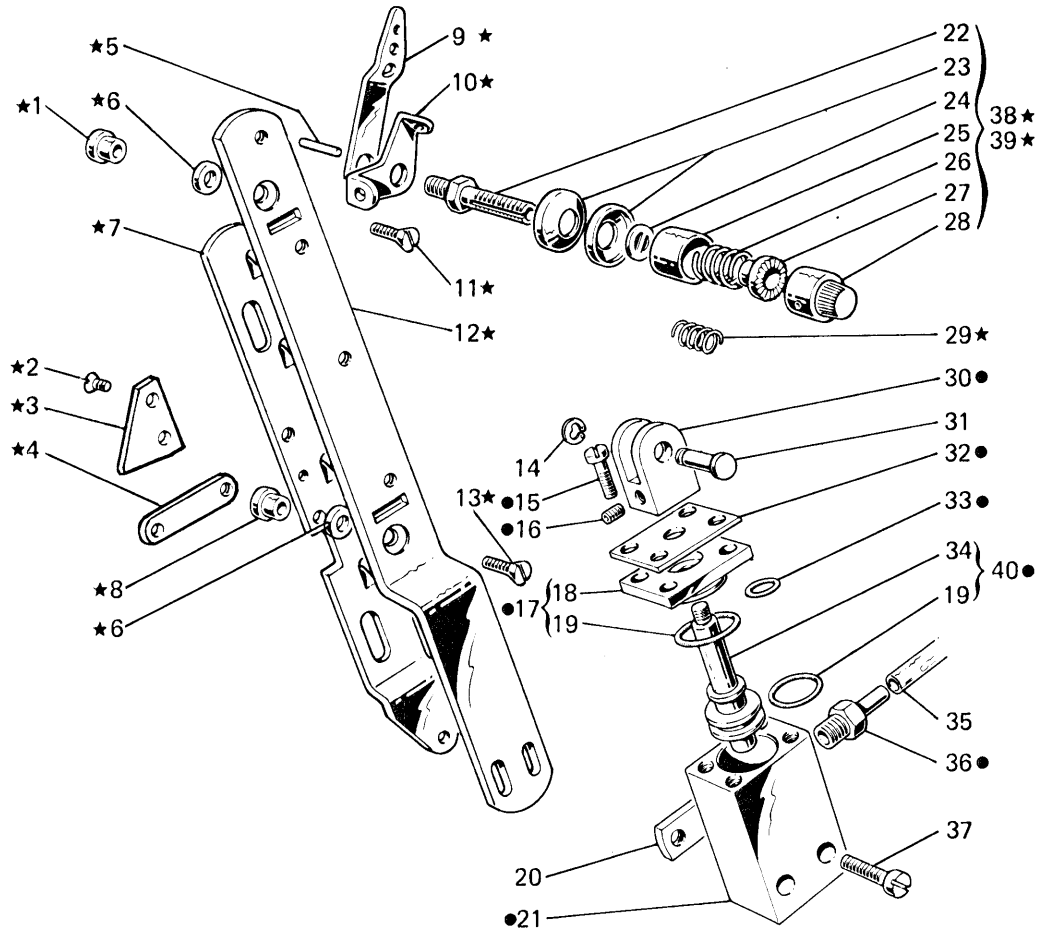

Fig. N. Abb. N.	Part. N. Bestell N. Piece N. Pieza N.	Qt. Anzahl	DESCRIZIONE	DESCRIPTION	DESCRIPTION	BENENNUNG	DESCRIPCION
★	924411-4-00	1	gruppo tensioni	tensions assembly	groupe tensions		
●	924735-4-11	1	valvola completa	valve assembly	soupape compl.		
1	924419-0-00	1	distanziale	spacer	entretoise		
2	724422-2-00	2	vite	screw	vis		
3	924417-0-00	1	piastrina	plate	plaque		
4	924418-0-00	1	piastrina	plate	plaque		
5	308506-0-00	3	pernetto	pin	pivot		
6	701007-0-00	2	anello	ring	anneau		
7	924416-0-00	1	slitta per tensione	slide for tension	glissière for tension		
8	308512-0-00	1	distanziale	spacer	entretoise		
9	308501-0-01	3	passafilo	thread guide	passe-fil		
10	308503-0-01	3	guidafilo	thread guide	guide-fil		
11	744696-2-00	1	vite	screw	vis		
12	926657-0-00	1	supporto	support	support		
13	744567-2-00	1	vite	screw	vis		
14	700205-0-00	1	anello elastico	spring ring	anneau ressort		
15	741495-0-00	4	vite	screw	vis		
16	745800-2-00	1	vite	screw	vis		
17	926669-4-00	1	flangia con anello di tenuta	flange	flasque		
18	924736-0-20	1	flangia	flange	flasque		
19	701009-0-00	2	anello di tenuta	retainer ring	anneau ressort		
20	924740-0-10	1	piastrina	plate	plaque		
21	924734-0-20	1	corpo	body	corps		
22	308505-0-00	3	perno a vite	threaded pin	pivot à vis		
23	300218-0-10	6	disco tensione	tension disc	disque tension		
24	308507-0-00	3	rondella	washer	rondelle		
25	202556-0-00	3	scodellino	cup	cuvette		
26	200710-0-10	2	molla	spring	ressort		
27	202229-0-10	3	bussola superiore	upper bush	bague supérieure		
28	202558-2-00	3	pomolo	knob	pommeau		
29	200714-0-10	1	molla	spring	ressort		
30	924739-0-10	1	forcella	fork	fourche		
31	202100-0-10	1	perno	pin	pivot		
32	924745-0-20	1	coperchio	cover	couvercle		
33	701104-0-00	1	anello di tenuta	retainer ring	anneau ressort		
34	924737-0-20	1	pistone	piston	piston		
35	790420-0-00	2	tubetto	pipe	tube		
36	924701-0-10	2	attacco per tubetto	pipe union	raccord pour tube		
37	721086-2-00	2	vite	screw	vis		
38	308518-4-00	2	tensione sup. con molla fig. 26	upper tension with spring fig. 26	tension sup. avec ressort fig. 26		
39	308521-4-00	1	tensione inf. con molla fig. 29	lower tension with spring fig. 29	tension inf. avec ressort fig. 29		
40	924738-4-20	1	pistone con anello di tenuta	piston with retainer ring	piston avec bague d'étanchéité		
			VARIANTE PER	VARIATION FOR	VARIANTE POUR		
			171-11-3MD-01	171-34-3MD-02			
★	924410-4-00	1	gruppo tensioni	tensions assembly	groupe tensions		
5	308506-0-00	4	pernetto	pin	pivot		
9	308501-0-01	4	passafilo	thread guide	passe-fil		

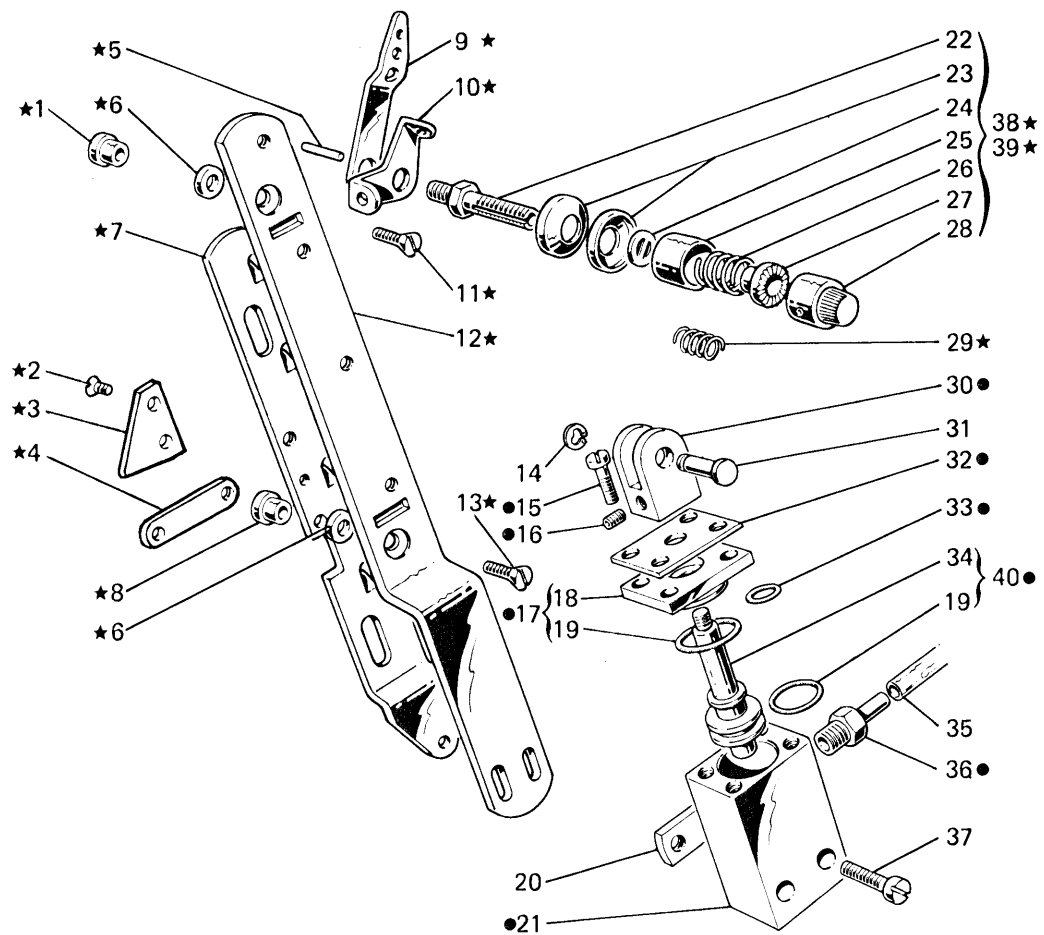

Fig. N. Abb. N.	Part. N. Bestell N. Piece N. Pieza N.	Qt. Anzahl	DESCRIZIONE	DESCRIPTION	DESCRIPTION	BENENNUNG	DESCRIPCION
10	308503-0-01	4	guidafilo	thread guide	guide-fil		
22	308505-0-00	4	perno a vite	threaded pin	pivot à vis		
23	300218-0-10	8	disco tensione	tension disc	disque tension		
24	308507-0-00	4	rondella	washer	rondelle		
25	202556-0-00	4	scodellino	cup	cuvette		
26	200710-0-10	3	molla	spring	ressort		
27	202229-0-10	4	bussola superiore	upper bush	bague supérieure		
28	202558-2-00	4	pomolo	knob	pommeau		
38	308518-4-00	3	tensione sup. con molla fig.26	upper tension with spring fig.26	tension sup. avec ressort fig. 26		

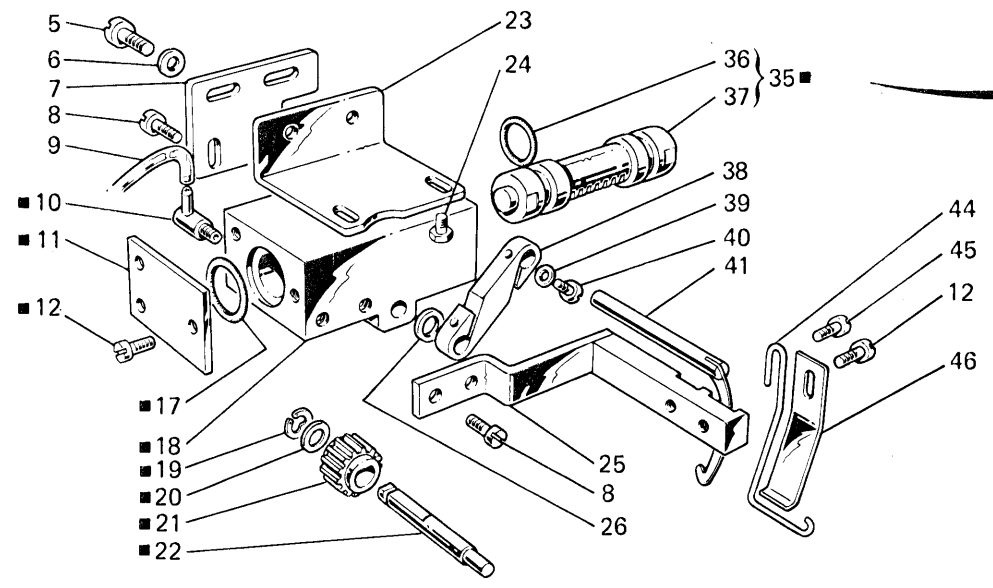
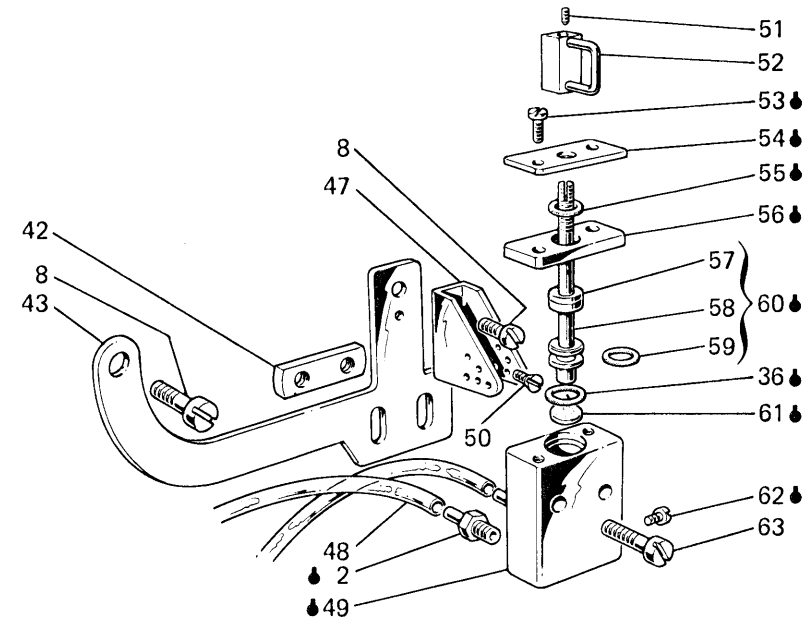
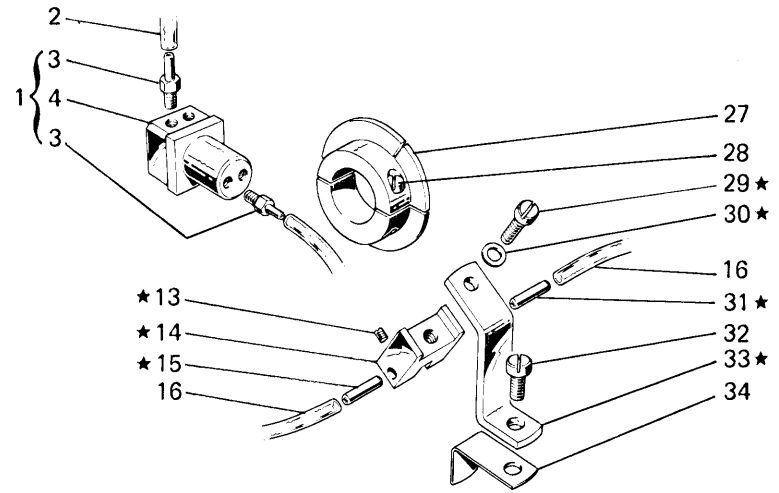

Fig. N. Abb. N.	Part. N. Bestell N. Piece N. Pieza N.	Qt. Anzahl	DESCRIZIONE	DESCRIPTION	DESCRIPTION	BENENNUNG	DESCRIPCION
★	924176-4-00	1	gruppo sensore fluidico	sensor group	groupe senseur		
●	926668-5-00	1	appinzatore completo (escluso figg.5-6-9-23-24)	gripping device assembly (excluded figs. 5-6-9-23-24)	dispositif pinceur complet (exclu figg. 5-6-9-23-24)		
■	924961-4-10	1	cilindro completo	cylinder assembly	cylindre complet		
▲	924723-5-10	1	tirafilo completo (escluso figg. 8-48)	thread take-up assembly (excluded figs. 8-48)	tendeur du fil complet (exclu figg. 8-48)		
⚙	924722-4-11	1	valvola completa	valve assembly	soupape complet		
1	924172-4-00	1	tappo completo	plug assembly	bouchon complet		
2	790407-0-00	2	tubetto	pipe	tube		
3	924701-0-11	6	attacco	pipe union	raccord pour tube		
4	924173-0-00	1	tappo	plug	bouchon		
5	721454-2-00	2	vite	screw	vis		
6	704210-4-00	2	rondella	washer	rondelle		
7	926667-0-00	1	piastrina	plate	plaque		
8	741936-0-00	6	vite	screw	vis		
9	790417-0-00	2	tubetto	pipe	tube		
10	924698-0-10	2	raccordo	pipe connection	raccord		
11	924972-0-00	2	coperchio	cover	couvercle		
12	741634-0-00	7	vite	screw	vis		
13	727012-0-00	2	vite	screw	vis		
14	924178-0-00	1	blocchetto	block	bloc		
15	924179-0-00	1	tubetto	pipe	tube		
16	790405-0-00	2	tubetto	pipe	tube		
17	701017-0-00	2	anello di tenuta	retainer ring	bague d'étanchéité		
18	924962-0-00	1	corpo	body	corps		
19	700005-0-00	1	anello elastico	spring ring	anneau ressort		
20	703802-0-00	1	rondella	washer	rondelle		
21	924965-0-10	1	pignone	pinion	pignon		
22	924973-0-10	1	albero	shaft	arbre		
23	926676-0-10	1	squadretta	bracket	équerre		
24	740031-2-00	2	vite	screw	vis		
25	924976-2-00	1	supporto	support	support		
26	704305-0-00	1	rondella	washer	rondelle		
27	924175-2-00	1	disco con vite	disc with screw	disque avec vis		
28	741579-0-00	2	vite	screw	vis		
29	741558-0-00	1	vite	screw	vis		
30	704104-2-00	1	rondella	washer	rondelle		
31	924180-0-00	1	tubetto	pipe	tube		
32	721444-2-00	1	vite	screw	vis		
33	924177-0-00	1	supporto	support	support		
34	924181-0-00	1	squadretta	bracket	équerre		
35	924964-4-00	1	pistone completo	piston assembly	piston complet		
36	701009-0-00	3	anello di tenuta	retainer ring	bague d'étanchéité		
37	924963-0-00	1	pistone	piston	piston		
38	924977-0-00	1	leva	lever	levier		
39	703003-0-00	2	rondella	washer	rondelle		
40	722410-2-00	2	vite	screw	vis		

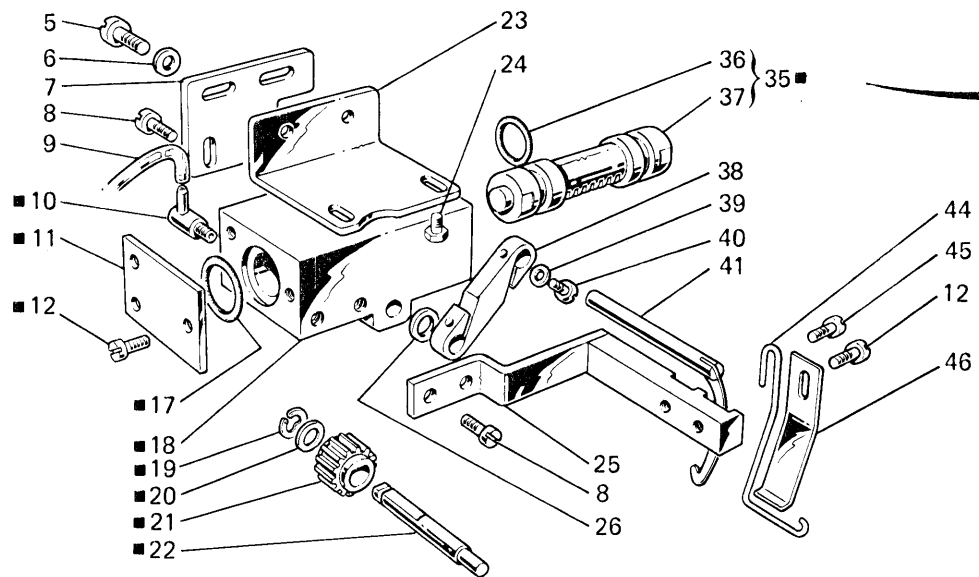
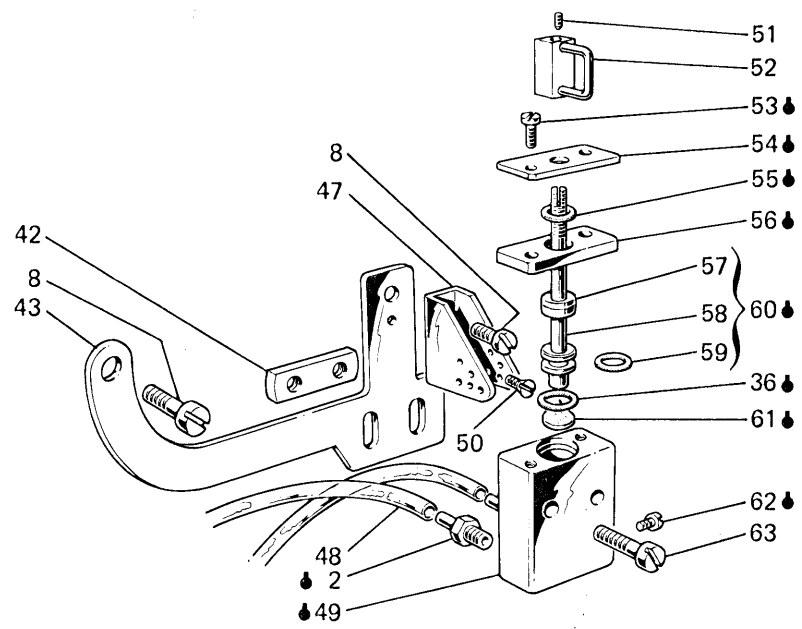
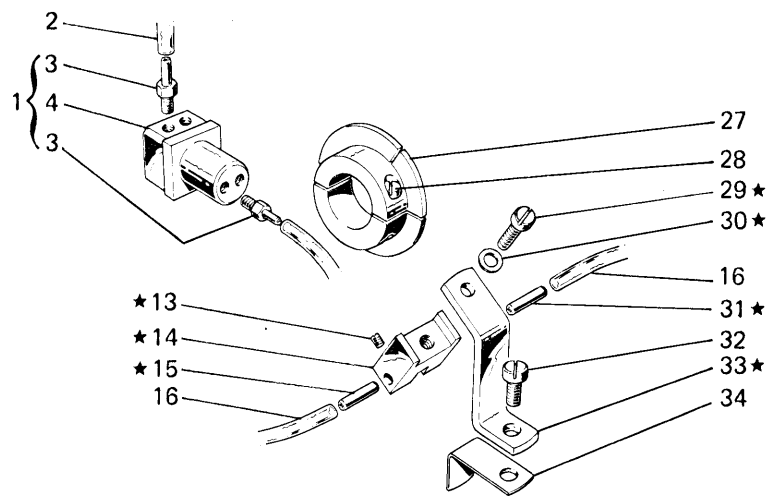

Fig. N. Abb. N.	Part. N. Bestell N. Piece N. Pieza N.	Qt. Anzahl	DESCRIZIONE	DESCRIPTION	DESCRIPTION	BENENNUNG	DESCRIPCION
41	924970-2-00	1	gancio	hook	crochet		
42	924730-0-10	1	piastrina	plate	plaque		
43	924727-0-10	1	sostegno	support	support		
44	924971-0-01	1	molla	spring	ressort		
45	741654-0-00	1	vite	screw	vis		
46	924974-0-01	1	molla	spring	ressort		
47	924729-0-10	1	passafilo	thread guide	passe-fil		
48	790408-0-00	2	tubetto	pipe	tube		
49	924721-0-10	1	corpo	body	corps		
50	724411-0-00	1	vite	screw	vis		
51	730041-2-00	1	vite	screw	vis		
52	924980-2-00	1	tendifil	thread take-up	tendeur du fil		
53	741495-0-00	2	vite	screw	vis		
54	924733-0-10	1	coperc	cover	couvercle		
55	701002-0-00	1	anello	retainer ring	bague d'étanchéité		
56	924726-0-10	1	coperc	cover	couvercle		
57	924731-0-10	1	amm	damper	amortisseur		
58	924724-0-11	1	pistone	piston	piston		
59	701104-0-00	1	anello di ten	retainer ring	bague d'étanchéité		
60	924725-4-11	1	pistoncino completo	piston assembly	piston complet		
61	924732-0-10	1	ammortizzatore	damper	amortisseur		
62	741405-4-00	3	tappo a vite	plug	bouchon		
63	721514-0-00	2	vite	screw	vis		

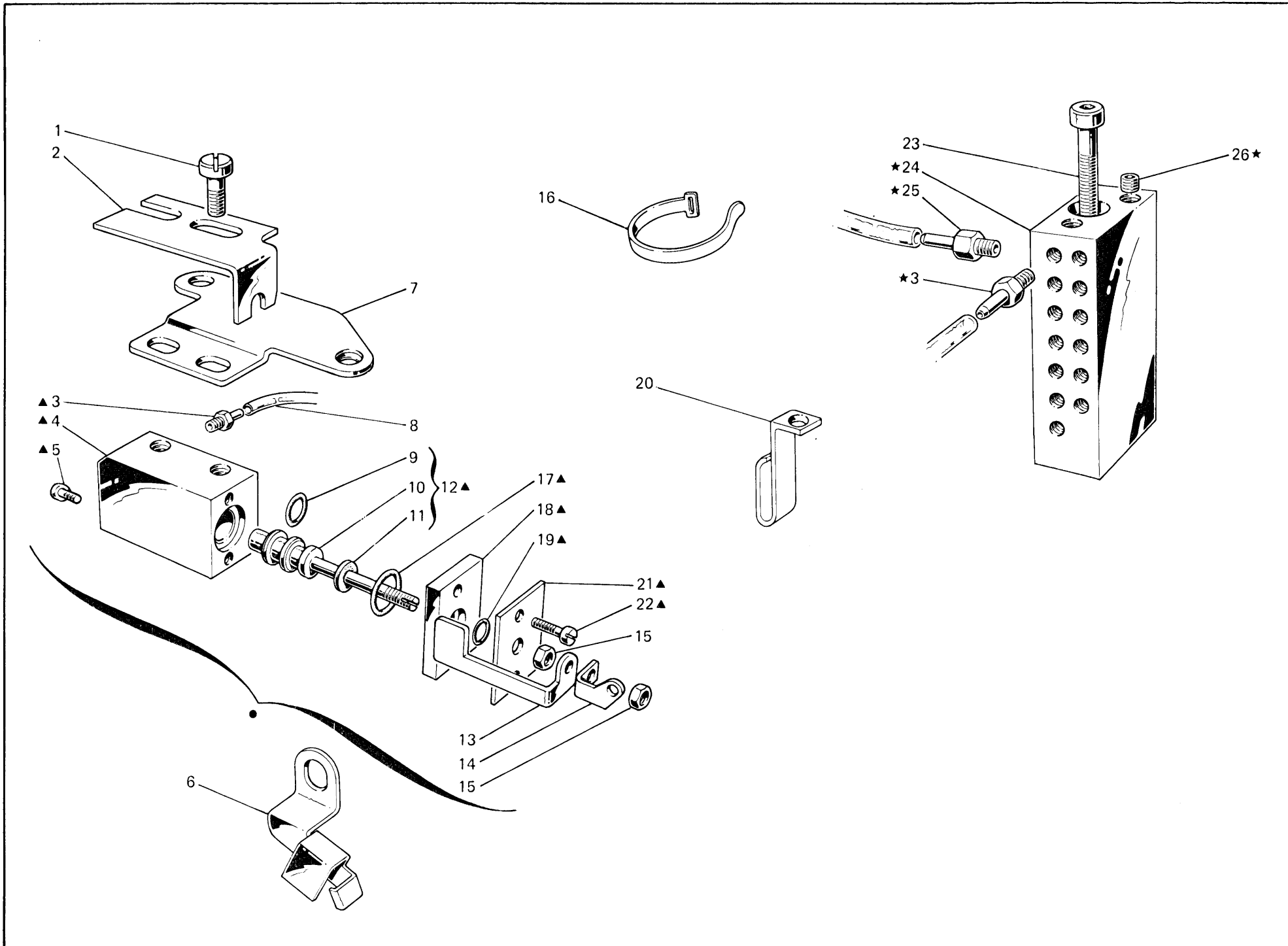

Fig. N. Abb. N.	Part. N. Bestell N. Piece N. Pieza N.	Qt. Anzahl	DESCRIZIONE	DESCRIPTION	DESCRIPTION	BENENNUNG	DESCRIPCION
●	924385-4-00	1	gruppo tirafilo	thread take-up assembly	groupe tendeur du fil		
▲	924684-4-11	1	valvola completa	valve assembly	soupape complète		
★	924162-4-00	1	distributore completo	distributeur assembly	distributeur complet		
1	741956-2-00	2	vite	screw	vis		
2	924693-0-11	1	squadretta	bracket	équerre		
3	924701-0-11	15	attacco	pipe union	raccord		
4	924683-0-11	1	corpo	body	corps		
5	741405-4-00	2	tappo a vite	plug	bouchon		
6	924480-0-00	1	supporto per tubetti	support for pipe	support pour tube		
7	924483-0-00	1	supporto	support	support		
8	790410-0-00	2	tubetto	pipe	tube		
9	701104-0-00	1	anello di tenuta	retainer ring	bague d'étanchéité		
10	924724-0-11	1	pistoncino	piston	piston		
11	924731-0-10	1	ammortizzatore	damper	amortisseur		
12	924725-4-11	1	pistoncino completo	piston assembly	piston complet		
13	924485-0-00	1	asta	rod	tige		
14	924484-0-00	1	tirafilo	thread take-up	tendeur du fil		
15	746002-2-00	2	dado	nut	écrou		
16	920258-0-10	2	cinturino	strap	bride		
17	701007-0-00	1	anello di tenuta	retainer ring	bague d'étanchéité		
18	924686-0-10	1	flangia	flange	flasque		
19	701002-0-00	1	anello di tenuta	retainer ring	bague d'étanchéité		
20	924497-0-00	1	fascetta	clamp	bride		
21	924692-0-10	1	coperchio	cover	couvercle		
22	741495-0-00	2	vite	screw	vis		
23	722583-2-00	1	vite	screw	vis		
24	924160-0-00	1	distributore	distributor	distributeur		
25	924797-0-10	5	attacco	pipe union	raccord		
26	745815-2-00	2	vite	screw	vis		

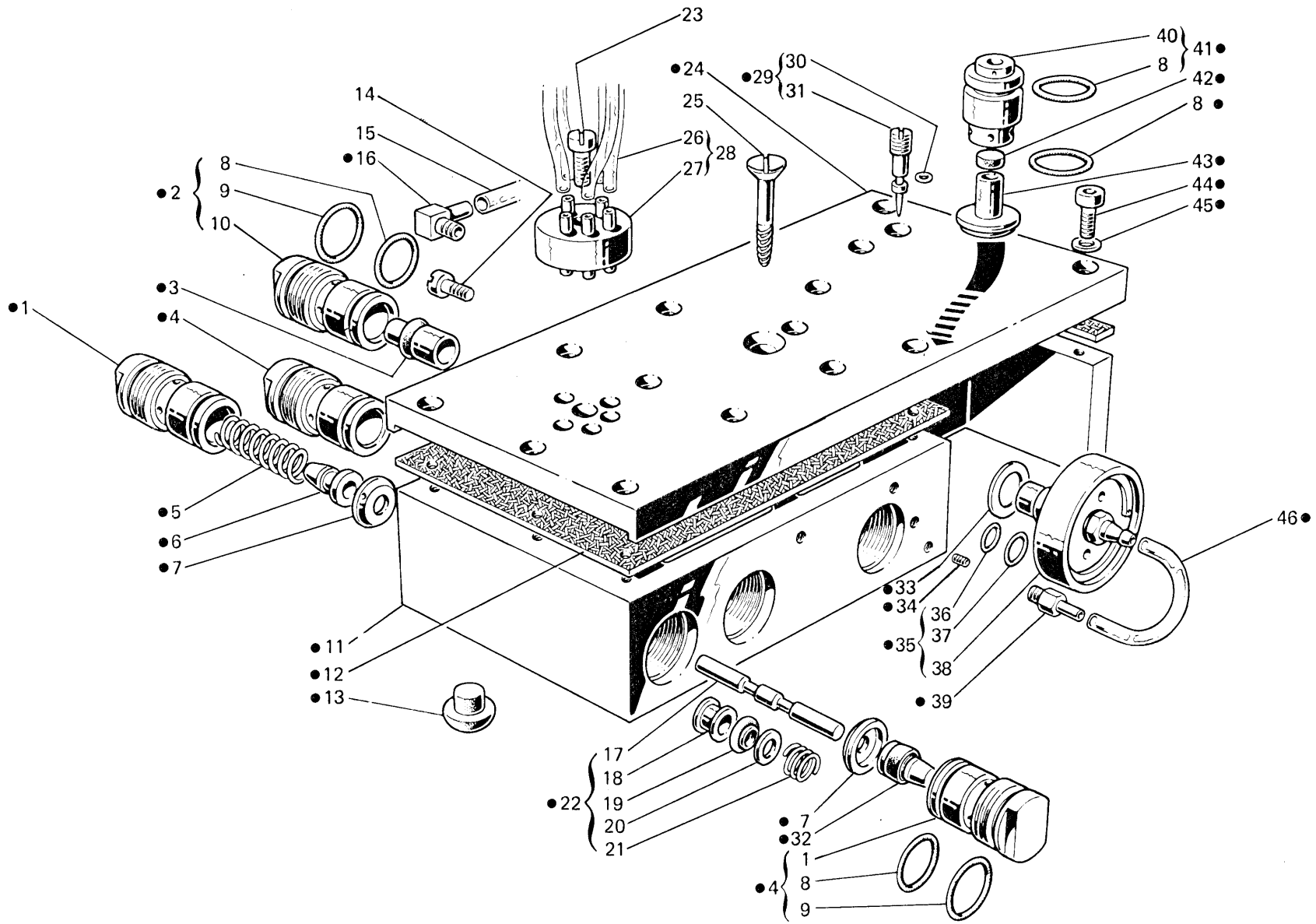

Fig. N. Abb. N.	Part. N. Bestell N. Piese N. Pieza N.	Qt. Anzahl	DESCRIZIONE	DESCRIPTION	DESCRIPTION	BENENNUNG	DESCRIPCION
●	924195-5-00	1	centralina completa	distributor assembly	distributeur complet		
1	924200-0-00	5	coperchio	cover	couvercle		
2	924216-4-00	1	coperchio con anello di tenuta	cover with retainer ring	couvercle avec bague d'étanchéité		
3	924214-4-00	1	pistone con guarnizione	piston with gasket	piston avec garniture		
4	924201-4-00	4	coperchio con anelli di tenuta	cover with retainer ring	couvercle avec bague d'étanchéité		
5	924202-0-00	1	molla	spring	ressort		
6	924203-0-00	1	pistone	piston	piston		
7	924206-0-00	6	distanziale	spacer	entretoise		
8	701023-0-00	7	anello di tenuta	retainer ring	bague d'étanchéité		
9	701120-0-00	5	anello di tenuta	retainer ring	bague d'étanchéité		
10	924215-0-00	1	coperchio	cover	couvercle		
11	924196-0-00	1	corpo	body	corps		
12	924198-0-00	1	guarnizione	gasket	garniture		
13	922797-0-00	3	gommino	dumper	caoutchouc		
14	741156-2-00	2	vite	screw	vis		
15	790051-0-00	1	tubetto	pipe	tube		
16	926409-0-00	1	raccordo	pipe connection	raccord		
17	924207-0-00	3	pistone	piston	piston		
18	924209-0-00	12	distanziale	spacer	entretoise		
19	924208-0-00	18	guarnizione	gasket	garniture		
20	924210-0-00	6	rondella	washer	rondelle		
21	924211-0-00	3	molla	spring	ressort		
22	924232-3-00	3	pistone completo	piston assembly	piston complet		
23	741177-0-00	1	vite	screw	vis		
24	924197-0-00	1	piastra di copertura	cover plate	plaque de couverture		
25	731367-0-00	1	vite da legno	screw	vis		
26	790507-0-00	5	tubetto	pipe	tube		
27	924168-2-00	1	disco	disc	disque		
28	924170-4-00	1	disco completo	disc assembly	disque complet		
29	924218-4-00	1	vite con anello di tenuta	screw with retainer ring	vis avec bague d'étanchéité		
30	701000-0-00	1	anello di tenuta	retainer ring	bague d'étanchéité		
31	924217-0-00	1	vite	screw	vis		
32	924205-4-00	4	pistone con guarnizione	piston with gasket	piston avec garniture		
33	703814-0-00	1	rondella	washer	rondelle		
34	729012-2-00	9	vite	screw	vis		
35	924223-4-00	1	valvola completa	valve assembly	soupape complète		
36	701007-0-00	1	anello di tenuta	retainer ring	bague d'étanchéité		
37	701011-0-00	1	anello di tenuta	retainer ring	bague d'étanchéité		
38	924222-0-00	1	valvola	valve	soupape		
39	924797-0-10	1	attacco	pipe union	raccord		
40	924219-0-00	1	coperchio	cover	couvercle		
41	924220-4-00	1	coperchio con anello di tenuta	cover with retainer ring	couvercle avec bague d'étanchéité		
42	923821-0-00	1	pastiglia	plug	bouchon		
43	924221-0-00	1	bussola inferiore	lower bush	bague inférieure		
44	722431-2-00	14	vite	screw	vis		
45	703005-0-00	14	rondella	washer	rondelle		
46	790502-0-00	1	tubetto	pipe	tube		

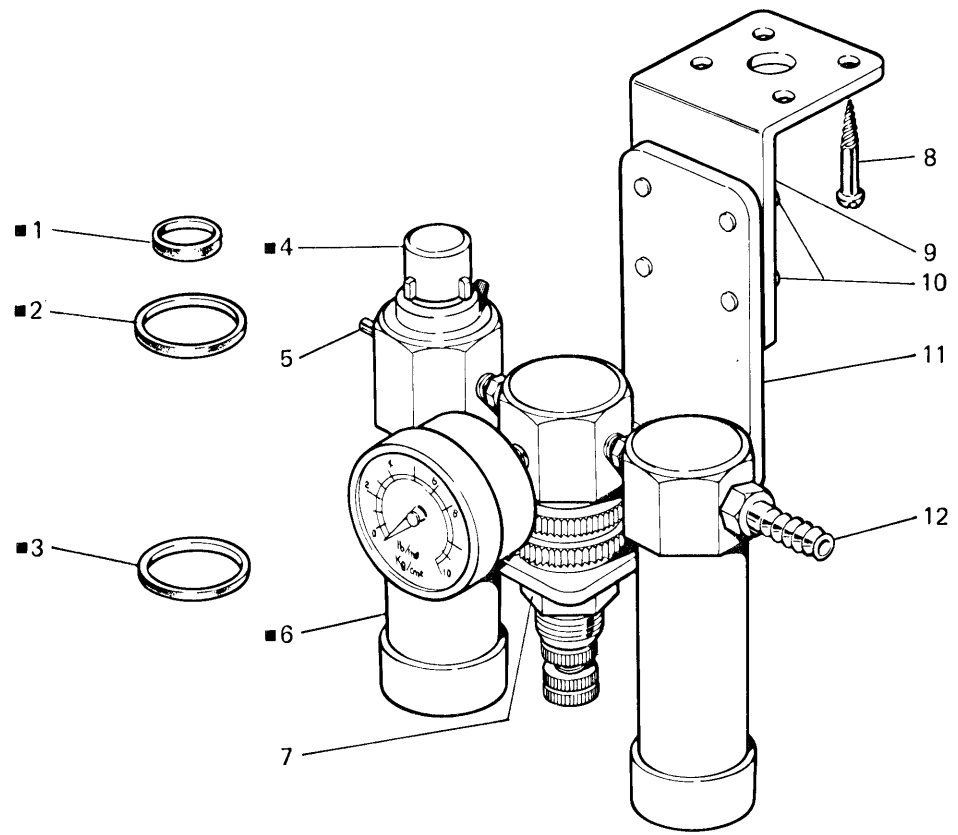

Fig. N. Abb. N.	Part. N. Bestell N. Piece N. Pieza N.	Qt. Anzahl	DESCRIZIONE	DESCRIPTION	DESCRIPTION	BENENNUNG	DESCRIPCION
★	926448-4-00	1	gruppo controllo aria (escluso fig. 8)	air control assembly (excluded fig. 8)	groupe contrôle aire (exclu fig. 8)		
■	925772-4-00	1	gruppo filtro	filter assembly	groupe filtre		
1	924994-0-00	1	guarnizione	gasket	garniture		
2	924991-0-00	2	guarnizione	gasket	garniture		
3	924990-0-00	2	guarnizione	gasket	garniture		
4	924993-0-00	1	cappello	cap	capuchon		
5	926303-0-00	1	attacco	pipe union	raccord pour tube		
6	924992-0-00	2	tazza	container	tasse		
7	924818-0-10	1	dado	nut	écrou		
8	731085-0-00	4	vite da legno	screw	vis		
9	925513-0-00	1	squadretta	bracket	équerre		
10	721444-2-00	4	vite	screw	vis		
11	924817-0-10	1	squadretta	bracket	équerre		
12	923804-0-00	1	attacco	pipe union	raccord pour tube		

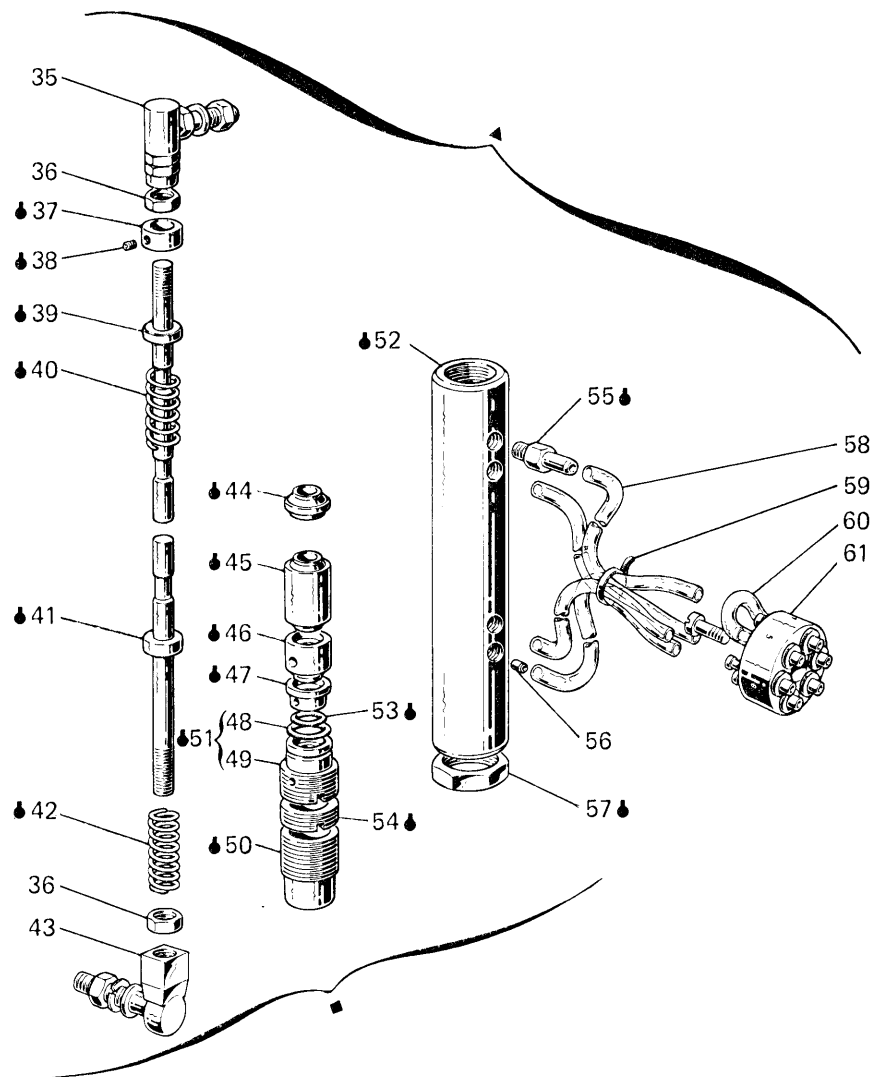
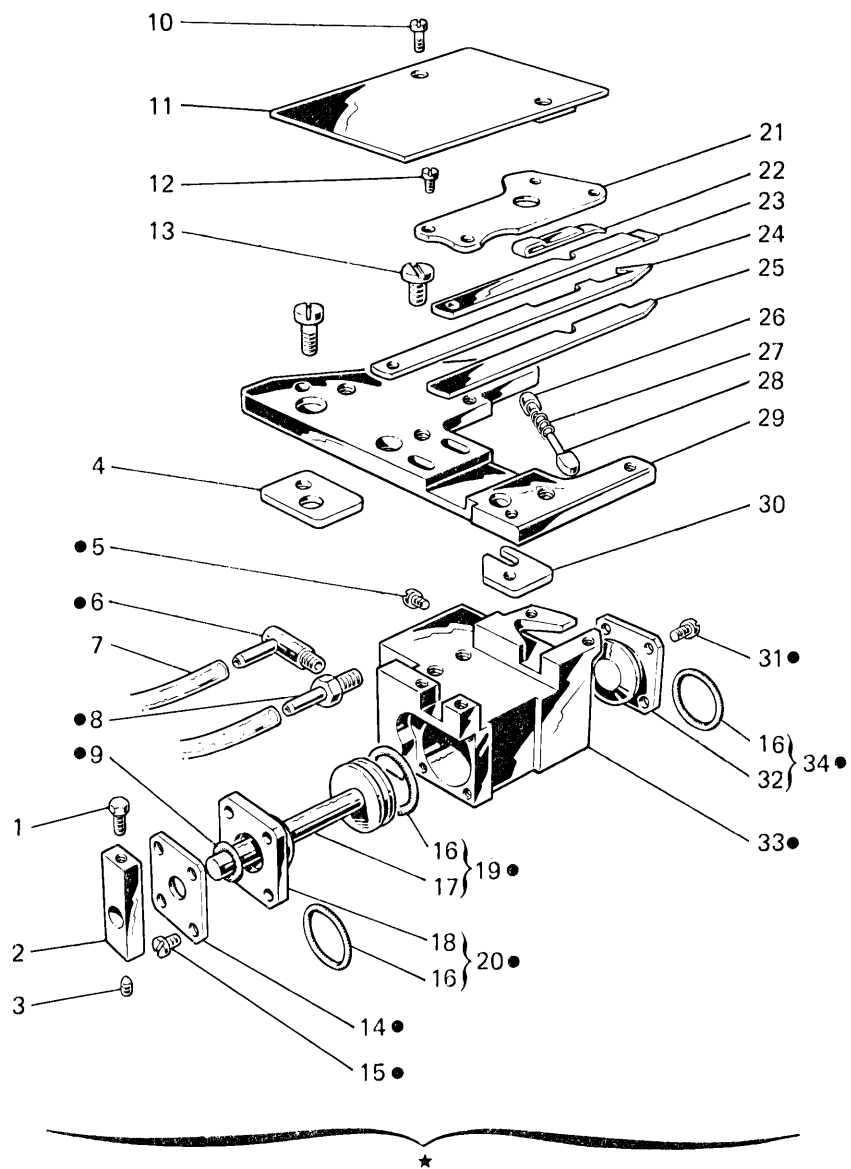

Fig. N. Abb. N.	Part. N. Bestell N. Piece N. Pieza N.	Qt. Anzahl	DESCRIZIONE	DESCRIPTION	DESCRIPTION	BENENNUNG	DESCRIPCION
★	924390-5-00	1	gruppo pistoncino (escluso figg. 4-7-10-11-30)	piston assembly (excluded figs. 4-7-10-11-30)	groupe piston (exclu fig. 4-7-10-11-30)		
●	924391-4-00	1	pistoncino completo	piston assembly	piston complet		
▲	924228-4-00	1	gruppo valvola	valve assembly	groupe soupape		
■	924787-5-10	1	valvola completa con giunti	valve assembly with joint	soupape complète avec joint		
●	924786-4-10	1	valvola completa	valve assembly	soupape complète		
1	924673-0-10	1	vite	screw	vis		
2	924668-0-10	1	fascetta	clamp	bride		
3	730011-2-00	1	vite	screw	vis		
4	924476-0-00	1	piastrina	plate	plaque		
5	741405-4-00	1	tappo a vite	plug	bouchon		
6	924392-0-00	1	attacco	pipe union	raccord pour tube		
7	790421-0-00	2	tubetto	pipe	tube		
8	924393-0-00	1	attacco	pipe union	raccord pour tube		
9	701003-0-00	1	anello di tenuta	retainer ring	bague d'étanchéité		
10	741913-4-00	2	vite	screw	vis		
11	924471-2-00	1	carterino	cover	carter		
12	744530-0-00	4	vite	screw	vis		
13	741956-2-00	2	vite	screw	vis		
14	924663-0-10	1	coperchio	cover	couvercle		
15	741461-0-00	4	vite	screw	vis		
16	701009-0-00	3	anello di tenuta	retainer ring	bague d'étanchéité		
17	924659-0-10	1	pistoncino	piston	piston		
18	924661-0-10	1	flangia	flange	flasque		
19	924660-4-10	1	pistoncino completo	piston assembly	piston complet		
20	924662-4-10	1	flangia completa	flange assembly	flasque complète		
21	924667-0-11	1	piastrina	plate	plaque		
22	924672-0-10	1	molla	spring	ressort		
23	924671-0-10	1	coltello superiore	upper knife	couteau supérieur		
24	924670-0-10	1	coltello	knife	couteau		
25	924669-0-10	1	lama inferiore	lower sheet	plaque inférieure		
26	924675-0-10	1	fulcro	fulcrum	pivot		
27	100893-0-09	1	molla	spring	ressort		
28	924674-0-10	1	perno	pin	pivot		
29	924472-2-00	1	piastra	plate	plaque		
30	924135-0-00	1	piastrina	plate	plaque		
31	741431-0-00	4	vite	screw	vis		
32	924664-0-11	1	flangia	flange	flasque		
33	924656-0-11	1	corpo	body	corps		
34	924665-4-11	1	flangia completa	flange assembly	flasque complète		
35	900941-0-00	1	giunto superiore	upper joint	joint supérieur		
36	746203-4-00	2	dado	nut	écrou		
37	924795-0-10	1	anello	ring	anneau		
38	745812-2-00	1	vite	screw	vis		
39	924794-0-10	1	pistoncino superiore	upper piston	piston supérieur		
40	302119-0-10	1	molla	spring	ressort		
41	924793-0-10	1	pistoncino inferiore	lower piston	piston inférieur		
42	203909-0-11	1	molla	spring	ressort		

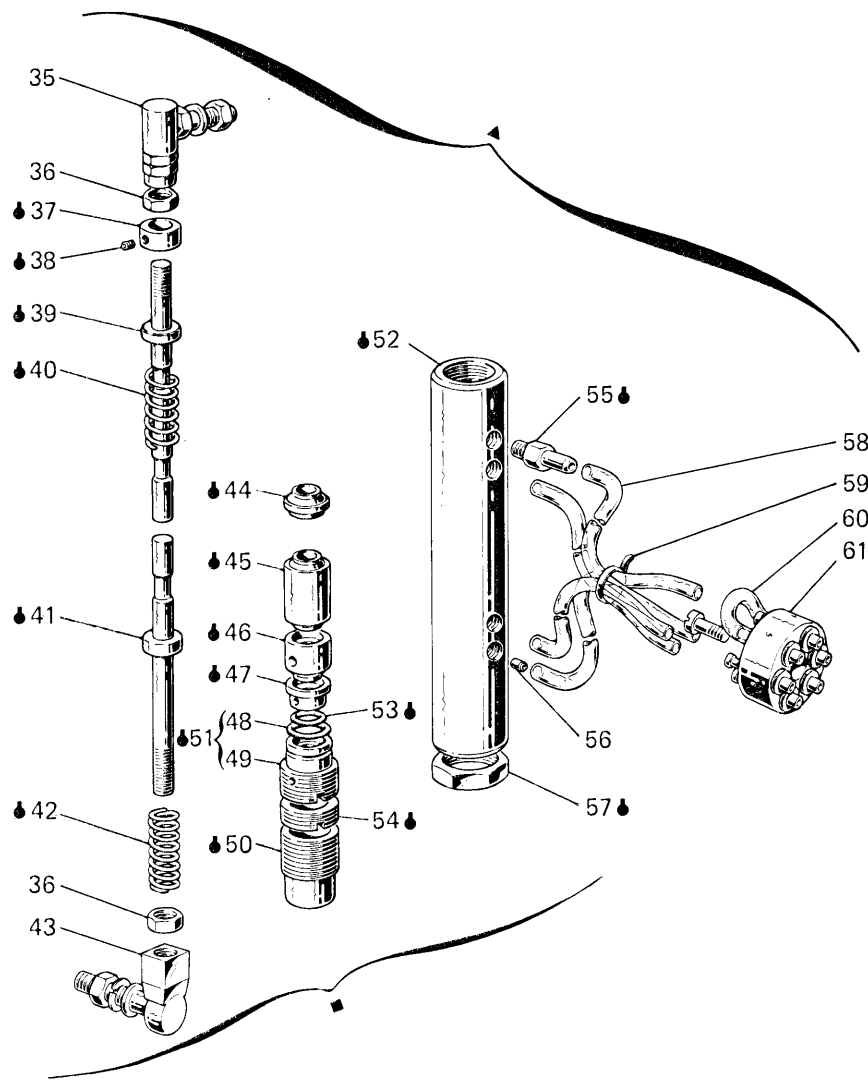
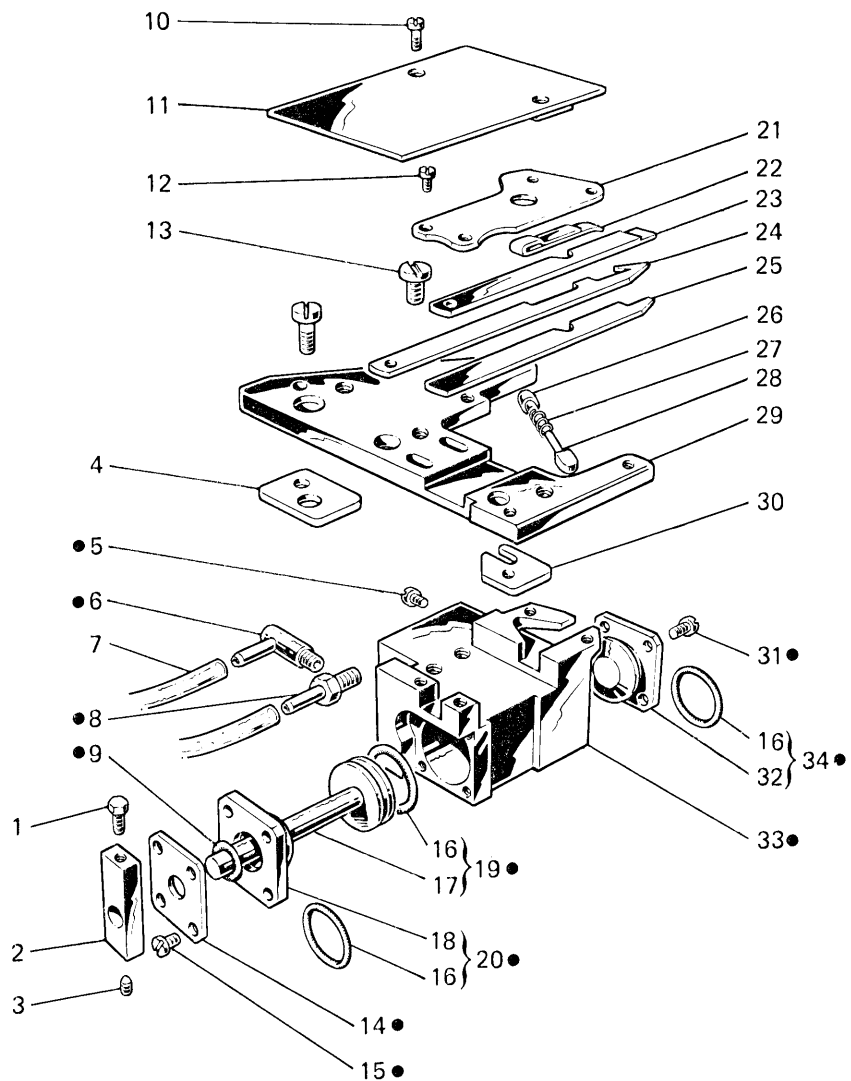

Fig. N. Abb. N.	Part. N. Bestell N. Pieze N. Pieza N.	Qt. Anzahl	DESCRIZIONE	DESCRIPTION	DESCRIPTION	BENENNUNG	DESCRIPCION
43	900942-0-00	1	giunto inferiore	lower joint	joint inférieur		
44	924798-0-10	1	distanziale	spacer	entretoise		
45	924792-0-10	1	bussola	bush	bague		
46	924791-0-10	2	distanziale	spacer	entretoise		
47	924799-0-10	3	distanziale	spacer	entretoise		
48	701113-0-00	7	anello di tenuta	retainer ring	bague d'étanchéité		
49	924788-0-10	2	ghiera	ring nut	collier		
50	924790-0-10	2	tappo	plug	bouchon		
51	924789-4-10	2	ghiera	ring nut	collier		
52	924785-0-10	1	cilindro	cylinder	cyindre		
53	701005-0-00	8	anello di tenuta	retainer ring	bague d'étanchéité		
54	924800-0-11	1	ghiera	ring nut	collier		
55	924797-0-10	4	attacco	pipe union	raccord		
56	924227-0-00	1	riduttore	reduction	réducteur		
57	924796-0-10	2	dado	nut	écrou		
58	790547-0-00	4	tubetto	pipe	tube		
59	920258-0-10	3	cinturino	strap	bride		
60	790504-0-00	1	tubetto	pipe	tube		
61	924169-2-00	1	disco	disc	disque		

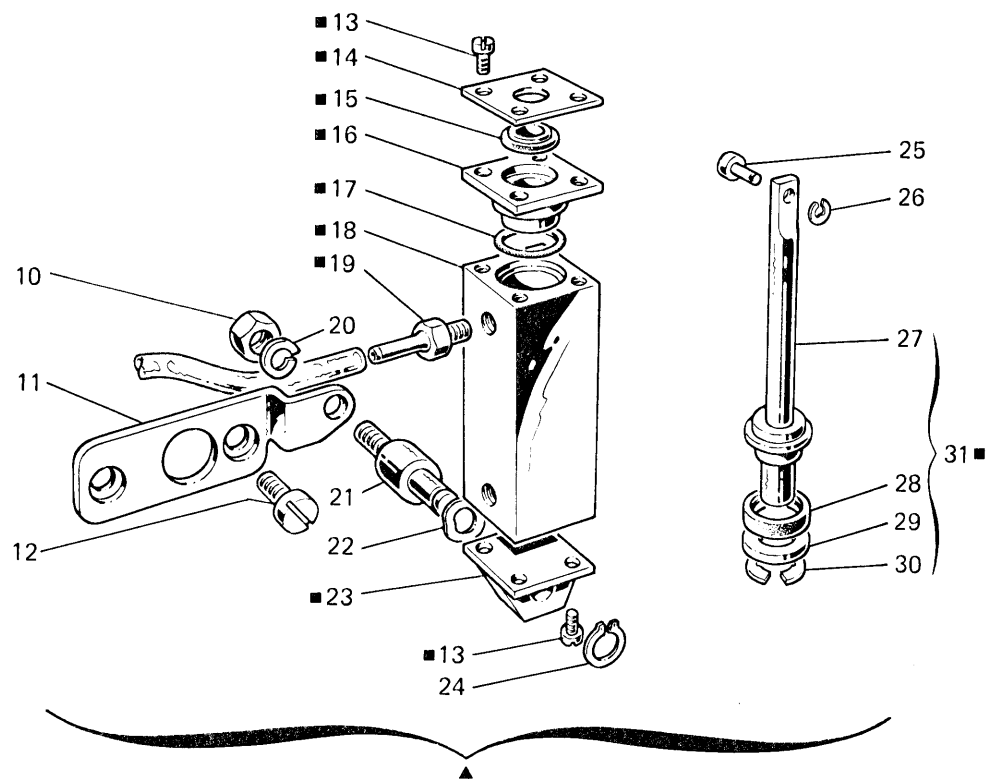
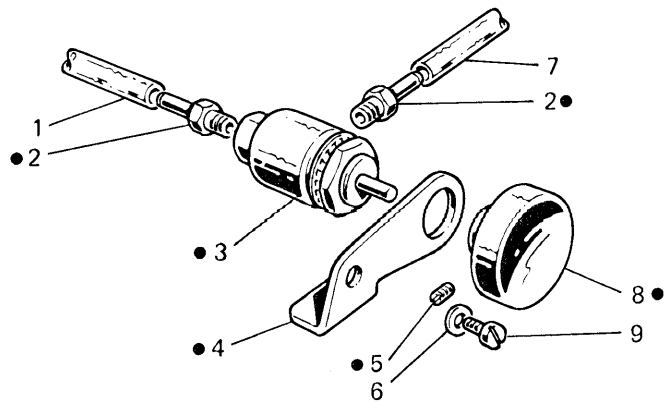

Fig. N. Abb. N.	Part. N. Bestell N. Piece N. Pieza N.	Qt. Anzahl	DESCRIZIONE	DESCRIPTION	DESCRIPTION	BENENNUNG	DESCRIPCION
●	925511-4-00	1	minivalvola completa	valve assembly	soupape complète		
▲	924381-4-00	1	gruppo pistone (escluso figg.7-12-25-26)	piston assembly (excluded figs.7-12-25-26)	groupe piston (exclu figs.7-12-25-26)		
■	924382-4-00	1	pistone completo	piston assembly	piston complet		
1	790413-0-00	1	tubetto	pipe	tube		
2	924784-0-10	2	attacco	pipe union	raccord pour tube		
3	924780-0-10	1	minivalvola	valve	soupape		
4	925510-0-00	1	supporto	support	support		
5	727032-0-00	1	vite	screw	vis		
6	704210-4-00	1	rondella	washer	rondelle		
7	790436-0-00	1	tubetto	pipe	tube		
8	924782-0-10	1	pomolo	knob	pommeau		
9	741937-0-00	1	vite	screw	vis		
10	746402-0-00	1	dado	nut	écrou		
11	924383-0-00	1	piastra	plate	plaque		
12	742214-2-00	2	vite	screw	vis		
13	741552-0-00	8	vite	screw	vis		
14	926265-0-00	1	coperchietto	cover	couvercle		
15	923828-4-00	1	anello di tenuta	retainer ring	bague d'étanchéité		
16	926266-0-01	1	flangia	flange	flasque		
17	701023-0-00	1	anello di tenuta	retainer ring	bague d'étanchéité		
18	926257-0-00	1	cilindro	cylinder	cylindre		
19	924380-0-00	1	attacco	pipe union	raccord pour tube		
20	703007-0-00	1	rondella elastica	spring washer	rondelle élastique		
21	926268-0-00	1	perno	pin	pivot		
22	926329-0-00	1	anello elastico	spring ring	anneau ressort		
23	926264-0-00	1	coperchio posteriore	rear cover	couvercle arrière		
24	700207-0-00	1	anello elastico	spring ring	anneau ressort		
25	203847-0-10	1	perno	pin	pivot		
26	700205-0-00	1	anello elastico	spring ring	anneau ressort		
27	926258-0-00	1	pistone	piston	piston		
28	926309-4-00	1	anello di tenuta	retainer ring	anneau d'étanchéité		
29	926267-0-00	1	rondella	washer	rondelle		
30	700209-0-00	1	anello elastico	spring ring	anneau ressort		
31	926259-4-00	1	pistone(con figg.27-28-29-30)	piston(with figs.27-28-29-30)	piston(avec figs.27-28-29-30)		

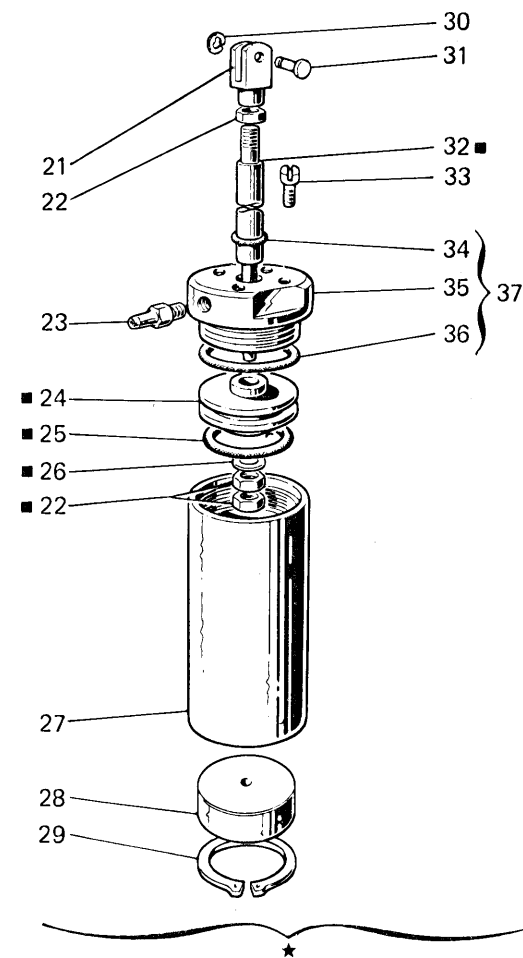
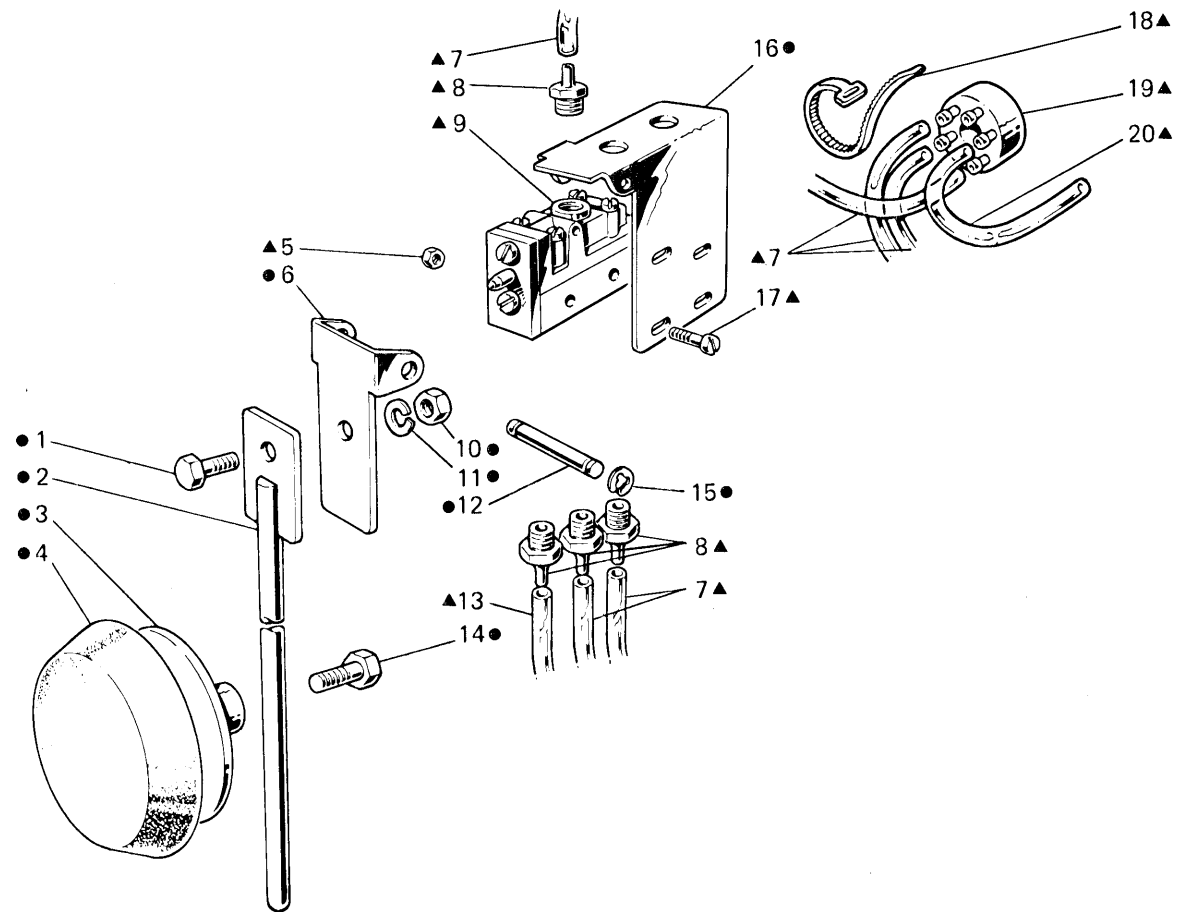

Fig. N. Abb. N.	Part. N. Bestell N. Piece N. Pieza N.	Qt. Anzahl	DESCRIZIONE	DESCRIPTION	DESCRIPTION	BENENNUNG	DESCRIPCION
▲	924230-4-00	1	gruppo ginocchiello (con ●)	knee-press group (with ●)	groupe genouillère (avec ●)		
—	924861-4-10	1	ginocchiello con attacchi (● con figg. 5-8-9-17)	knee-press with pipe union (● with figs. 5-8-9-17)	genouillère avec raccord (● avec figg. 5-8-9-17)		
●	924864-4-10	1	ginocchiello completo	knee-press assembly	genouillère complète		
★	924185-4-00	1	gruppo pistone (escluso figg. 31-32-34)	piston group (excluded figs. 31-32-34)	groupe piston (exclu figg. 31-32-34)		
■	924186-4-00	1	pistone completo	piston assembly	piston complet		
1	720464-2-00	1	vite	screw	vis		
2	924866-2-10	1	asta	rod	tige		
3	920105-0-10	1	disco	disc	disque		
4	920113-0-10	1	cuscinò	pad	coussin		
5	733505-0-00	3	dado	nut	écrou		
6	924863-0-10	1	piastra mobile	movable plate	plaque mobile		
7	790547-0-00	3	tubetto	pipe	tube		
8	924870-0-10	4	attacco	pipe union	raccord		
9	924869-0-10	1	valvola	valve	soupape		
10	746203-4-00	1	dado	nut	écrou		
11	703008-0-00	1	rondella	washer	rondelle		
12	924868-0-10	1	perno	pin	pivot		
13	790537-0-00	1	tubetto	pipe	tube		
14	740035-0-00	1	vite	screw	vis		
15	700207-0-00	2	anello elastico	spring ring	anneau ressort		
16	924860-0-10	1	piastra	plate	plaque		
17	722153-0-00	3	vite	screw	vis		
18	920258-0-10	3	cinturino	strap	bride		
19	924167-2-00	1	disco completo	disc assembly	disque complet		
20	790522-0-00	1	tubetto	pipe	tube		
21	990310-0-10	1	forcella	fork	fourche		
22	746402-0-00	3	dado	nut	écrou		
23	924797-0-10	1	attacco	pipe union	raccord		
24	924187-0-01	1	pistone	piston	piston		
25	701121-0-00	1	anello di tenuta	retainer ring	bague d'étanchéité		
26	704218-2-00	1	rondella	washer	rondelle		
27	924190-0-00	1	cilindro	cylinder	cylindre		
28	924191-0-00	1	tappo inferiore	lower plug	bouchon inférieur		
29	700124-0-00	1	anello elastico	spring ring	anneau ressort		
30	700205-0-00	1	anello elastico	spring ring	anneau ressort		
31	990311-0-10	1	perno	pin	pivot		
32	924808-0-10	1	albero	shaft	arbre		
33	721474-2-00	3	vite	screw	vis		
34	701007-0-00	1	anello di tenuta	retainer ring	bague d'étanchéité		
35	924189-0-00	1	tappo superiore	upper plug	bouchon supérieur		
36	701033-0-00	1	anello di tenuta	retainer ring	bague d'étanchéité		
37	924188-4-00	1	tappo sup. con anello di tenuta	upper plug with retainer ring	bouchon sup. avec bague d'étanchéité		

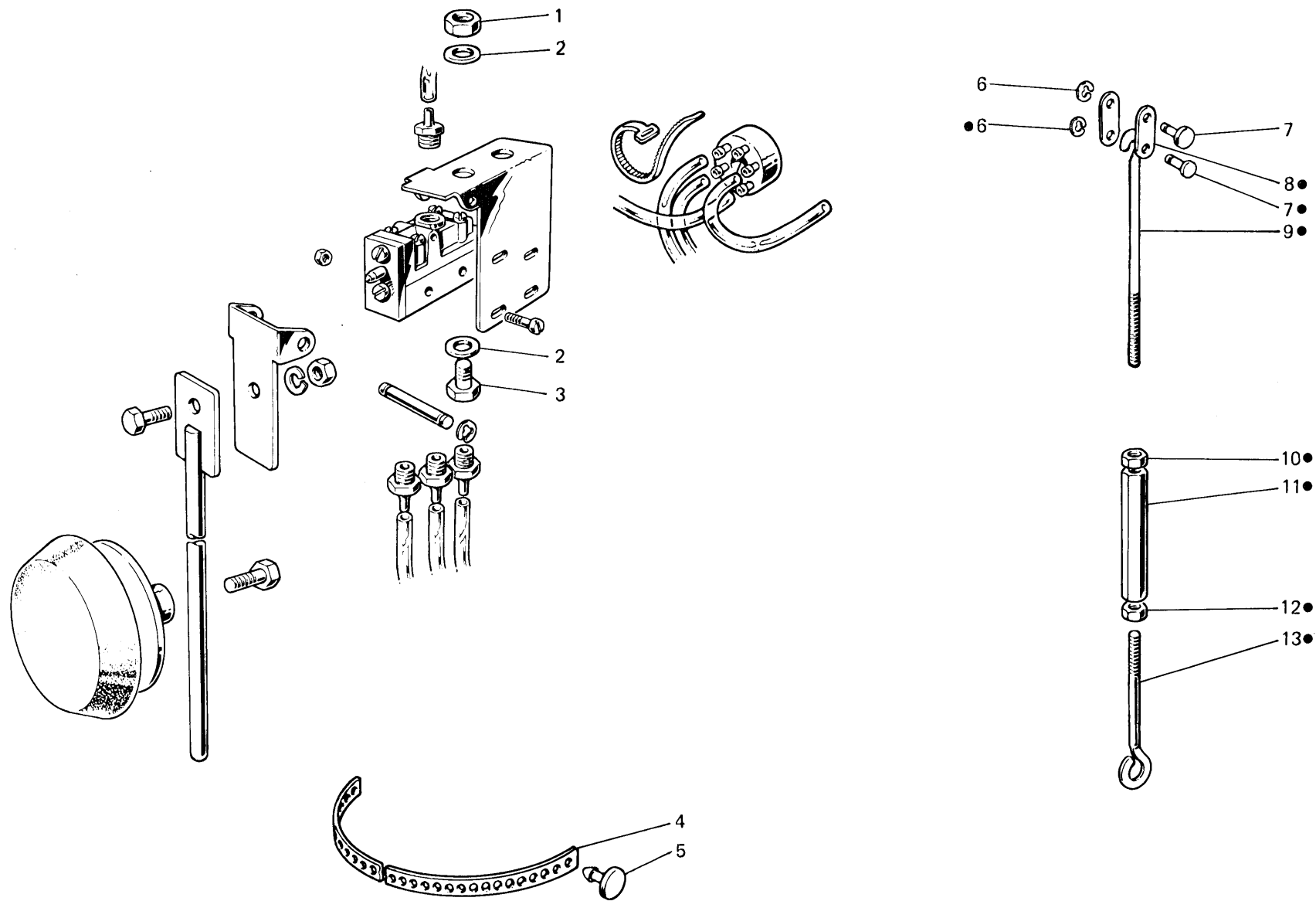

Fig. N. Abb. N.	Part. N. Bestell N. Pieza N.	Qt. Anzahl	DESCRIZIONE	DESCRIPTION	DESCRIPTION	BENENNUNG	DESCRIPCION
●	910214-4-11	1	tirante completo	tie-rod assembly	tirant complet		
1	733510-2-00	1	dado	nut	écrou		
2	704232-2-00	2	rondella	washer	rondelle		
3	720485-2-00	1	vite	screw	vis		
4	990441-0-10	3	cinturino	strap	bride		
5	990442-0-10	3	bottoncino	button	bouton		
6	700205-0-00	2	anello elastico	spring ring	anneau ressort		
7	203211-0-10	2	perno	pin	pivot		
8	990765-0-00	2	piastrina	plate	plaque		
9	910187-0-11	1	tirante superiore	upper tie-rod	tirant supérieur		
10	733505-2-00	1	dado	nut	écrou		
11	910190-0-10	1	bussola	bush	bague		
12	746601-2-00	1	dado	nut	écrou		
13	910213-0-10	1	tirante inferiore	lower tie-rod	tirant inférieur		

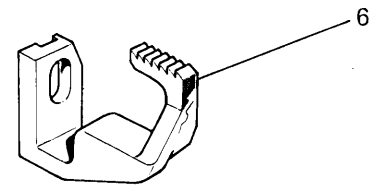
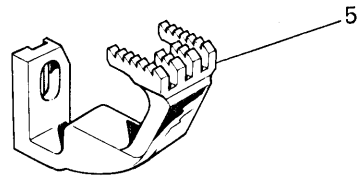
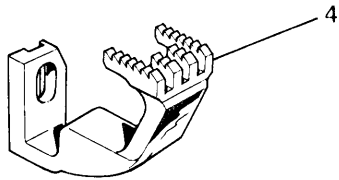
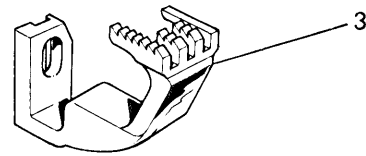
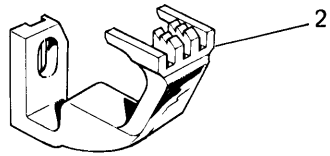
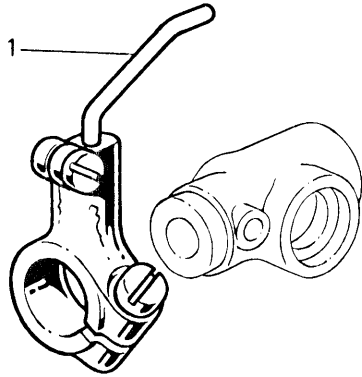

Fig. N. Abb. N.	Part. N. Bestell N. Piece N. Pieza N.	Qt. Anzahl	DESCRIZIONE	DESCRIPTION	DESCRIPTION	BENENNUNG	DESCRIPCION
1	924652-0-10	1	spingi asola SOLO PER TESTA	front needle guard ONLY FOR HEAD 171-10-2MD-01	pare-boucle SEULEMENT POUR TETE		
2	924526-0-01	1	griffa differenziale SOLO PER TESTA	differential feed dog ONLY FOR HEAD 171-10-2MD-03	griffe différentielle SEULEMENT POUR TETE		
3	924450-0-00	1	griffa differenziale SOLO PER TESTA	differential feed dog ONLY FOR HEAD 171-11-2MD-02	griffe différentielle SEULEMENT POUR TETE		
4	924509-0-11	1	griffa differenziale SOLO PER TESTA	differential feed dog ONLY FOR HEAD 171-11-3MD-01	griffe différentielle SEULEMENT POUR TETE		
5	924553-0-11	1	griffa differenziale SOLO PER TESTA	differential feed dog ONLY FOR HEAD 171-34-3MD-02	griffe différentielle SEULEMENT POUR TETE		
6	924551-0-11	1	griffa differenziale	differential feed dog	griffe différentielle		

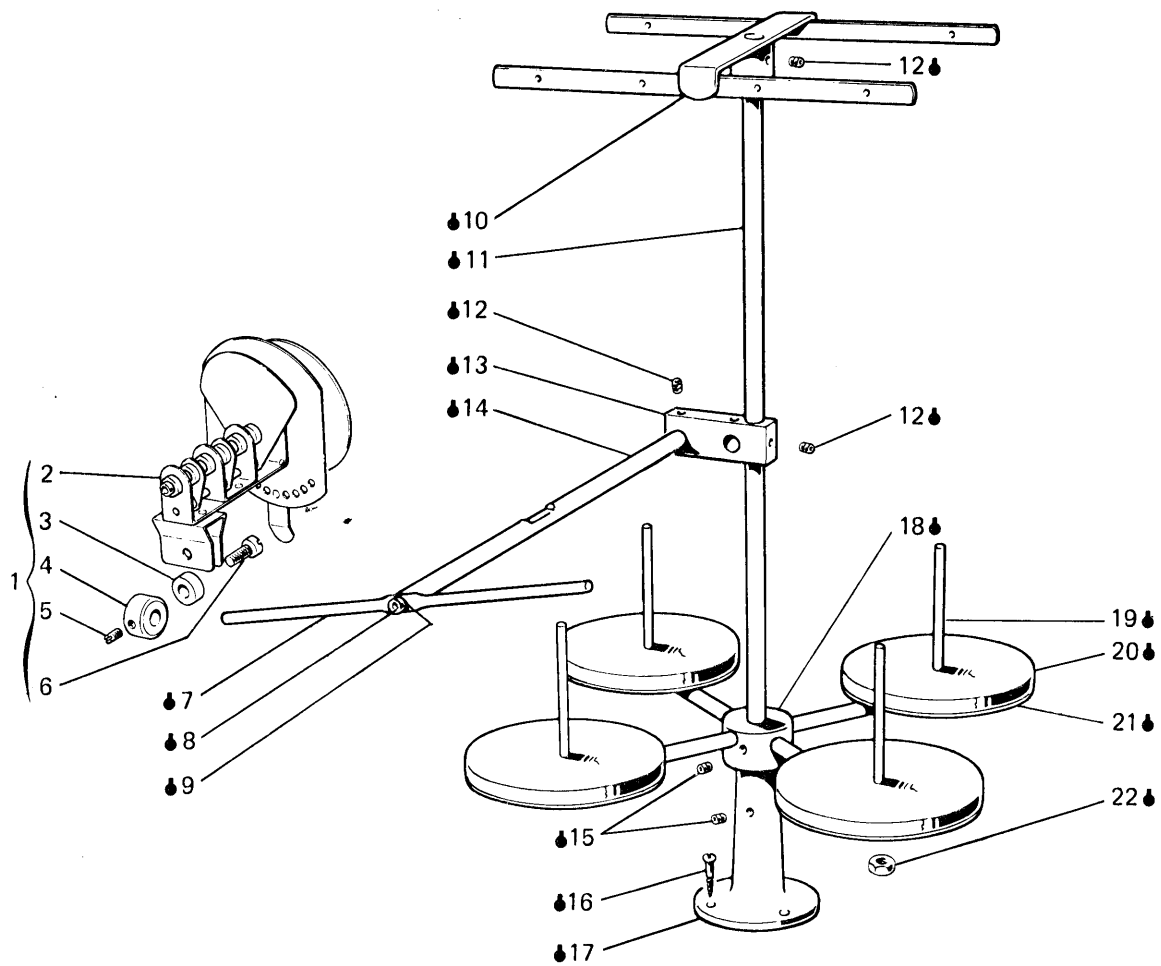

Fig. N. Abb. N.	Part. N. Bestell N. Piece N. Pieza N.	Qt. Anzahl	DESCRIZIONE	DESCRIPTION	DESCRIPTION	BENENNUNG	DESCRIPCION
•	924155-5-00	1	porta bobine completo (3-4fili)	bobbin carrier ass. (3-4 threads)	porte bobine compl. (3-4 fils)		
1	991158-4-00	3	frenaggio completo	brake assembly	freinage complet		
2	990445-0-10	3	frenaggio	brake	freinage		
3	304257-0-10	3	distanziale	spacer	entretoise		
4	991159-0-00	3	anello	ring	anneau		
5	727014-2-00	3	vite	screw	vis		
6	741956-2-00	3	vite	screw	vis		
7	991152-0-00	1	astina	rod	tige		
8	722431-2-00	1	vite	screw	vis		
9	703005-0-00	1	rondella	washer	rondelle		
10	991121-3-00	1	telaietto super. con vite	upper frame with screw	bâti supérieur avec vis		
11	991113-0-00	1	asta principale	main rod	tige principale		
12	729034-2-00	3	vite	screw	vis		
13	991128-2-00	1	blocchetto con viti	block with screws	bloc avec vis		
14	991106-2-00	1	asta con rondella e vite	rod with washer and screw	tige avec rondelle et vis		
15	729054-2-00	3	vite	screw	vis		
16	731107-2-00	3	vite da legno	screw	vis		
17	991114-2-00	1	basetta con vite	base with screw	base avec vis		
18	991129-3-00	1	mozzo con aste e viti	hub with rods and screws	moyeu avec tiges et vis		
19	991111-2-00	4	astina con dadi	rod with nuts	tige avec écrou		
20	991179-0-00	4	disco	disc	disque		
21	991112-0-00	4	piatto	disc	plateau		
22	733508-2-00	8	dado	nut	écrou		
			VARIANTE PER	VARIATION FOR	VARIANTE POUR		
			171-11-3MD-01	171-34-3MD-02			
1	991158-4-00	4	frenaggio completo	brake assembly	freinage complet		
2	990445-0-10	4	frenaggio	brake	freinage		
3	304257-0-10	4	distanziale	spacer	entretoise		
4	991159-0-00	4	anello	ring	anneau		
5	727014-2-00	4	vite	screw	vis		
6	741956-2-00	4	vite	screw	vis		

APPARECCHIATURA ATTACHMENT DISPOSITIF VORRICHTUNG

551-41

PER TESTA 171-11-2MK-04
FOR HEAD
POUR TETE
FÜR OBERTEILE

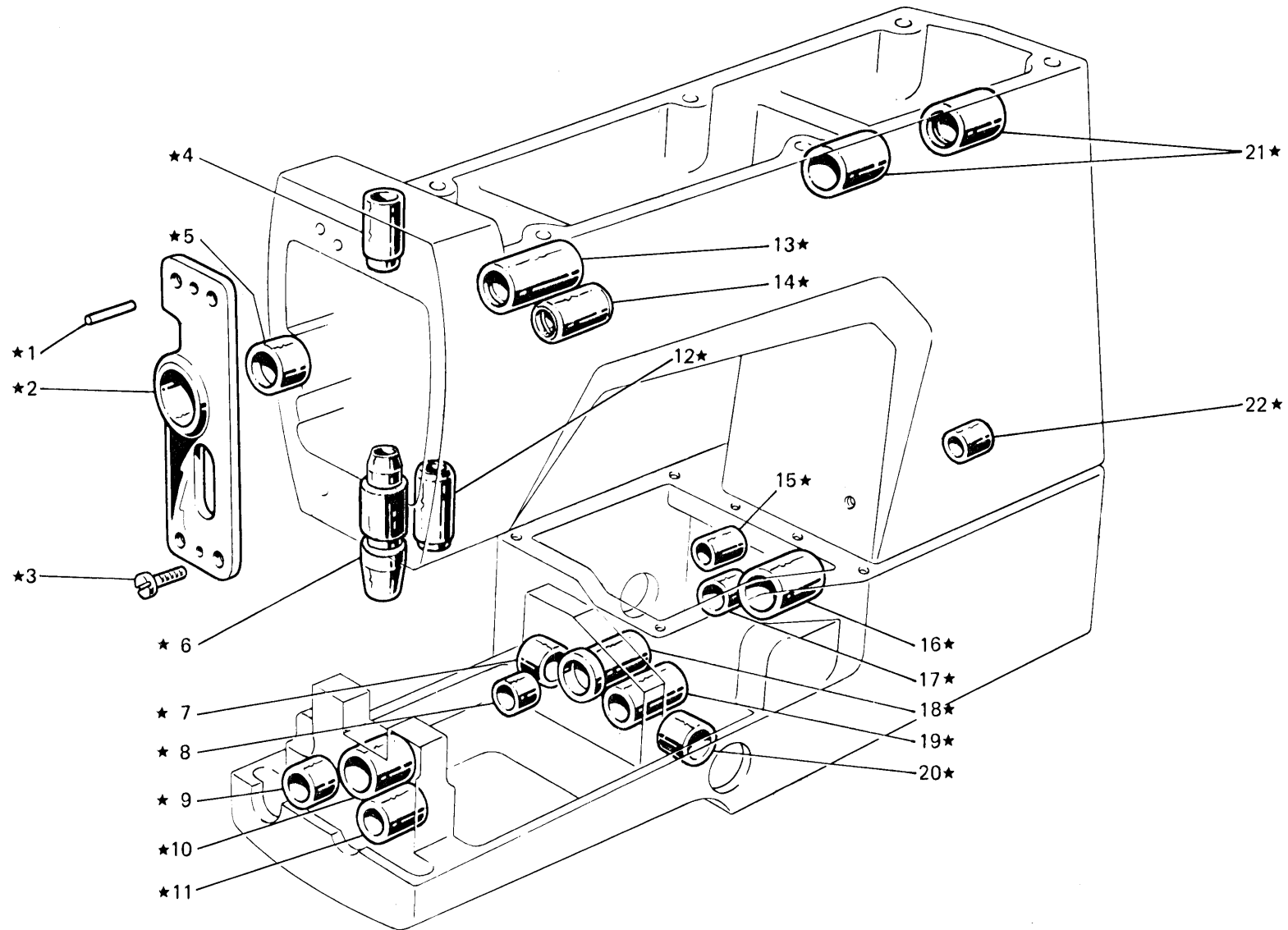

Fig. N. Abb. N.	Part. N. Bestell N. Piece N. Pieza N.	Qt. Anzahl	DESCRIZIONE	DESCRIPTION	DESCRIPTION	BENENNUNG	DESCRIPCION
★	924376-3-00	1	base e braccio con bussole	base and arm with bushes	base et bras avec bagues		
1	706454-0-00	2	spina	pin	goupille		
2	308859-2-00	1	supporto con bussola fig. 5	support with bush fig. 5	support avec bague fig.5		
3	721485-2-00	4	vite	screw	vis		
4	308032-0-00	1	bussola	bush	bague		
5	308858-0-00	1	bussola	bush	bague		
6	308411-0-00	1	bussola	bush	bague		
7	311007-0-00	1	bussola	bush	bague		
8	311180-0-00	1	bussola	bush	bague		
9	311168-0-00	1	bussola	bush	bague		
10	311003-0-00	1	bussola	bush	bague		
11	311008-0-00	1	bussola	bush	bague		
12	308031-0-00	1	bussola	bush	bague		
13	308852-0-00	1	bussola	bush	bague		
14	308232-0-00	1	bussola	bush	bague		
15	311116-0-00	1	bussola	bush	bague		
16	308086-0-00	1	bussola	bush	bague		
17	311009-0-00	1	bussola	bush	bague		
18	311004-0-10	1	bussola	bush	bague		
19	308298-0-00	1	bussola	bush	bague		
20	311006-0-00	1	bussola	bush	bague		
21	308853-0-00	2	bussola	bush	bague		
22	311167-0-00	1	bussola	bush	bague		

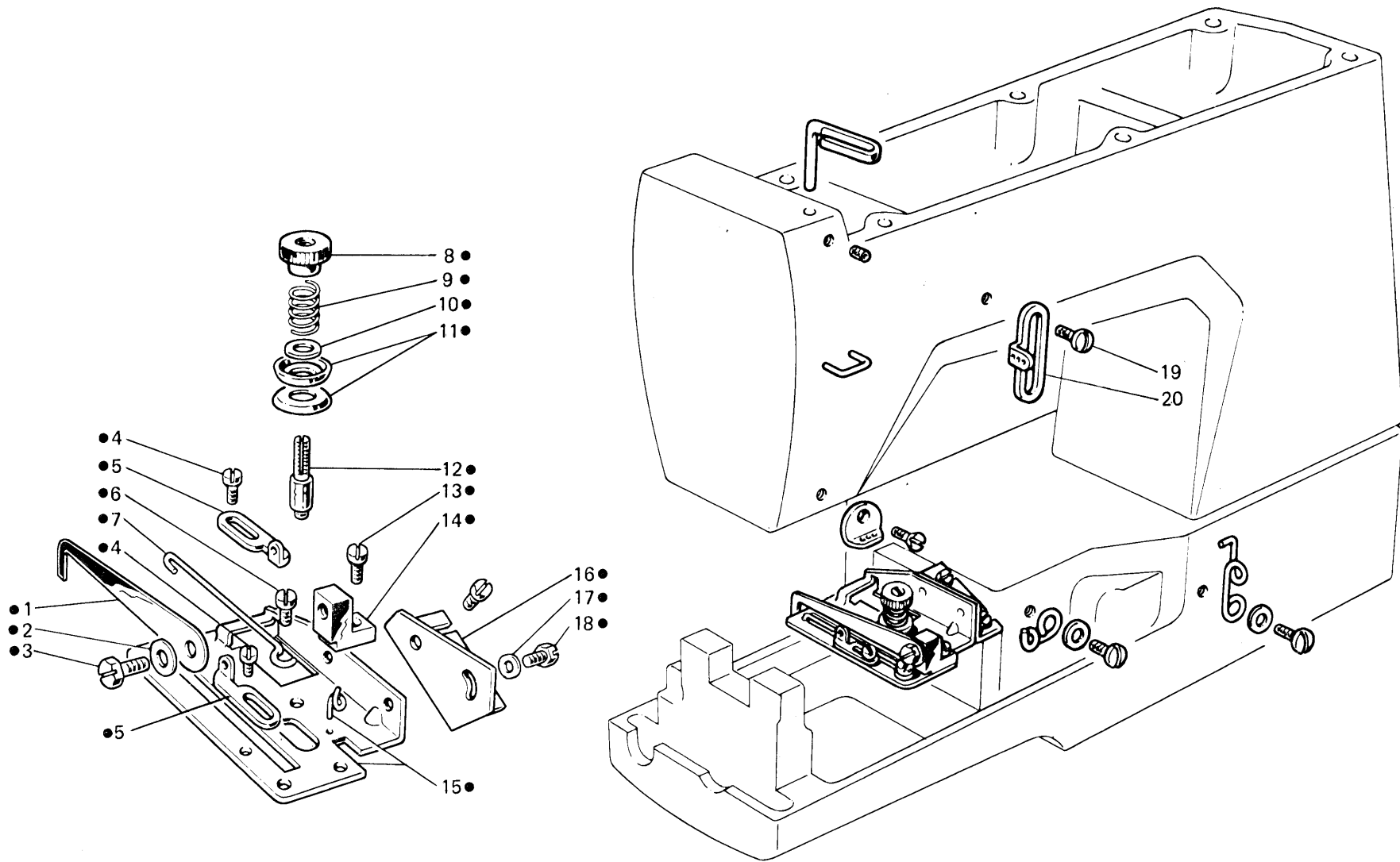

Fig. N. Abb. N.	Part. N. Bestell N. Piece N. Pieza N.	Qt. Anzahl	DESCRIZIONE	DESCRIPTION	DESCRIPTION	BENENNUNG	DESCRIPCION
●	924394-4-00	1	gruppo tensione crochet inf.	lower looper tension ass.	groupe tensions crochet inf.		
1	308556-0-00	1	astina	rod	tige		
2	705201-0-00	1	rondella	washer	rondelle		
3	740220-2-00	1	vite	screw	vis		
4	741413-2-00	2	vite	screw	vis		
5	302172-0-10	2	passafilo	thread guide	passe-fil		
6	741612-0-00	1	vite	screw	vis		
7	308558-0-00	1	traversino	tie	traverse		
8	302204-0-10	1	pomolo	knob	pommeau		
9	300310-0-10	1	molla	spring	ressort		
10	704218-2-00	1	rondella	washer	rondelle		
11	200324-0-10	2	disco tensione	tension disc	disque tension		
12	300391-0-10	1	perno a vite	threaded pin	pivot à vis		
13	741642-2-00	1	vite	screw	vis		
14	302168-2-10	1	supporto	support	support		
15	924395-2-00	1	piastra	plate	plaque		
16	311188-0-00	1	squadretta	bracket	équerre		
17	704302-4-00	2	rondella	washer	rondelle		
18	740210-2-00	2	vite	screw	vis		
19	303045-0-10	1	vite	screw	vis		
20	308203-0-01	1	guidafilo	thread guide	guide-fil		

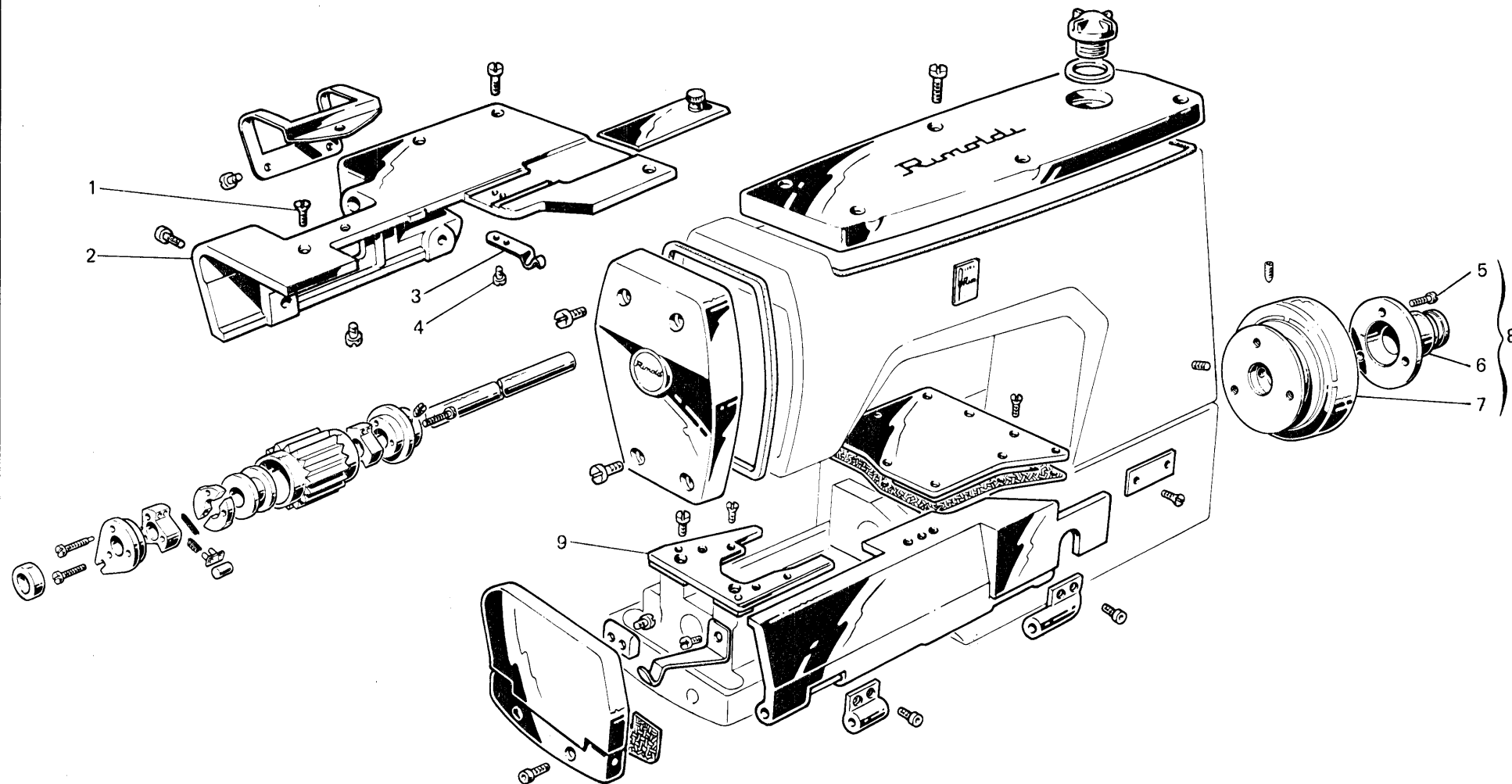

Fig. N. Abb. N.	Part. N. Bestell N. Piece N. Pieza N.	Qt. Anzahl	DESCRIZIONE	DESCRIPTION	DESCRIPTION	BENENNUNG	DESCRIPCION
1	744636-2-00	1	vite	screw	vis		
2	924446-3-00	1	piano di lavoro con figg. 3-4	working plate with figs 3-4	plan de travail avec figg. 3-4		
3	311242-0-00	1	molla	spring	ressort		
4	742812-2-00	2	vite	screw	vis		
5	741974-2-00	3	vite	screw	vis		
6	302247-0-10	1	flangia	flange	flasque		
7	924365-0-00	1	volantino	handwheel	volant		
8	924405-4-00	1	volantino completo	handwheel assembly	volant complet		
			PEZZI ANNULLATI	CANCELLED PARTS	PIECES ANNULEES		
9	311226-2-00	1	piastra porta placca	plate	plaque		

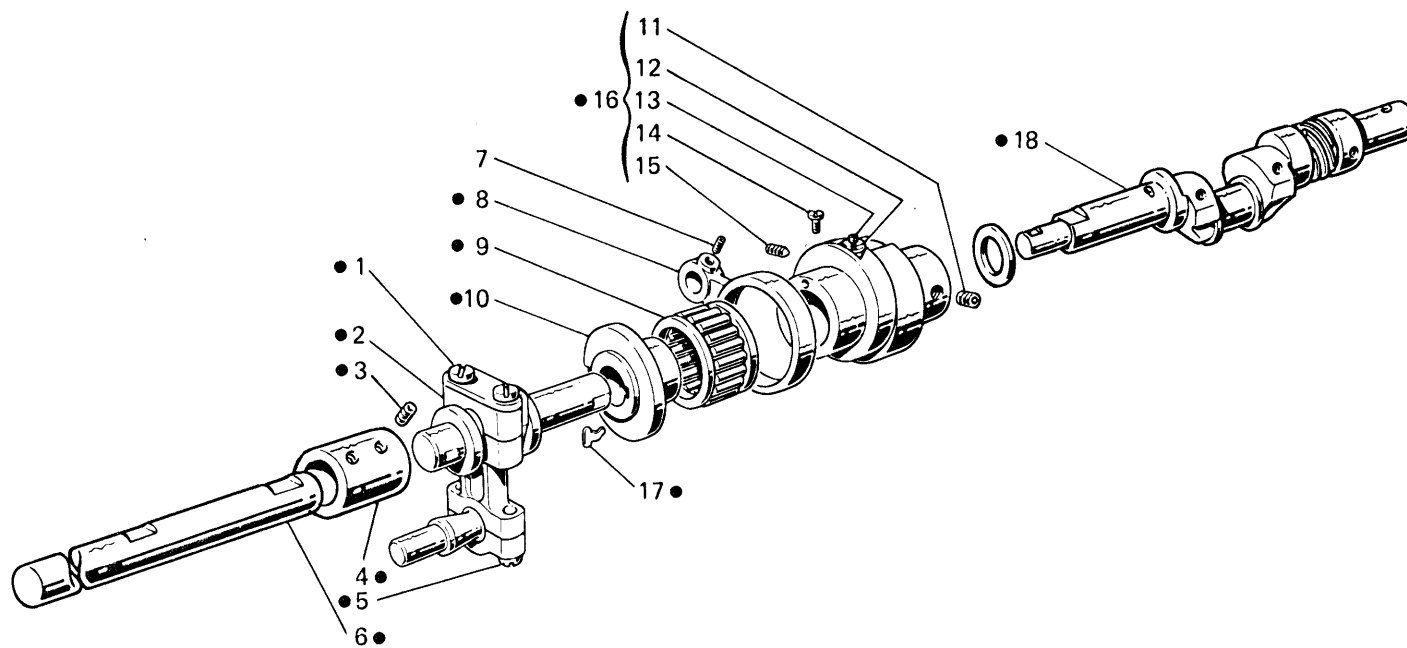

Fig. N. Abb. N.	Part. N. Piece N. Bestell N. Pieza N.	Qt. Anzahl	DESCRIZIONE	DESCRIPTION	DESCRIPTION	BENENNUNG	DESCRIPCION
●	311364-4-00	1	gruppo albero inferiore	lower shaft assembly	groupe arbre inférieur		
1	311021-0-00	2	vite per biella	screw for con-rod	vis pour bielle		
2	311030-3-10	1	biella completa con viti	con rod assembly with screws	bielle compl.avec vis		
3	745827-2-00	4	vite	screw	vis		
4	311014-0-00	1	manicotto	coupling	manchon		
5	308802-0-00	2	vite per biella	screw for con-rod	vis pour bielle		
6	311088-2-10	1	semialbero inferiore sinistro	left lower half-shaft	semi-arbre inférieur gauche		
7	745811-2-00	1	vite	screw	vis		
8	311105-0-00	1	biella comando trasporto	transport control con-rod	beille commande crochet		
9	311186-0-00	1	gabbia a rullini	needle cage	cage à aiguille		
10	311022-0-00	1	eccentrico spostamento	eccentric	excentrique		
11	729024-2-00	4	vite	screw	vis		
12	206603-0-10	1	fermo per eccentrico	eccentric retainer	pièce pour excentrique		
13	729051-2-00	1	vite per fermo	screw	vis		
14	202473-0-10	2	vite	screw	vis		
15	202472-0-10	2	vite	screw	vis		
16	311015-4-01	1	eccentrico regolabile trasporto	eccentric	excentrique		
17	206872-0-00	1	molla	spring	ressort		
18	311190-3-01	1	semilabero inferiore destro	right lower halft-shaft	semi-arbre inférieur droite		

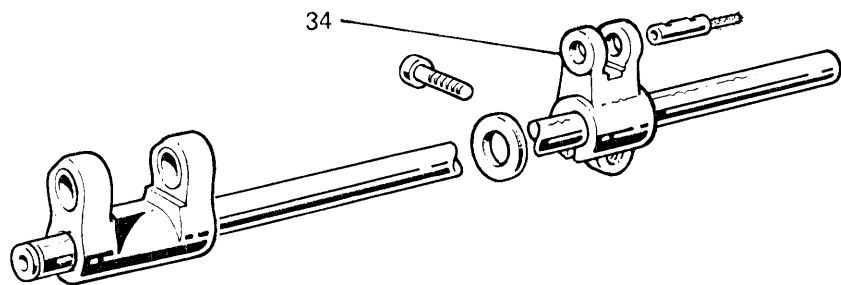
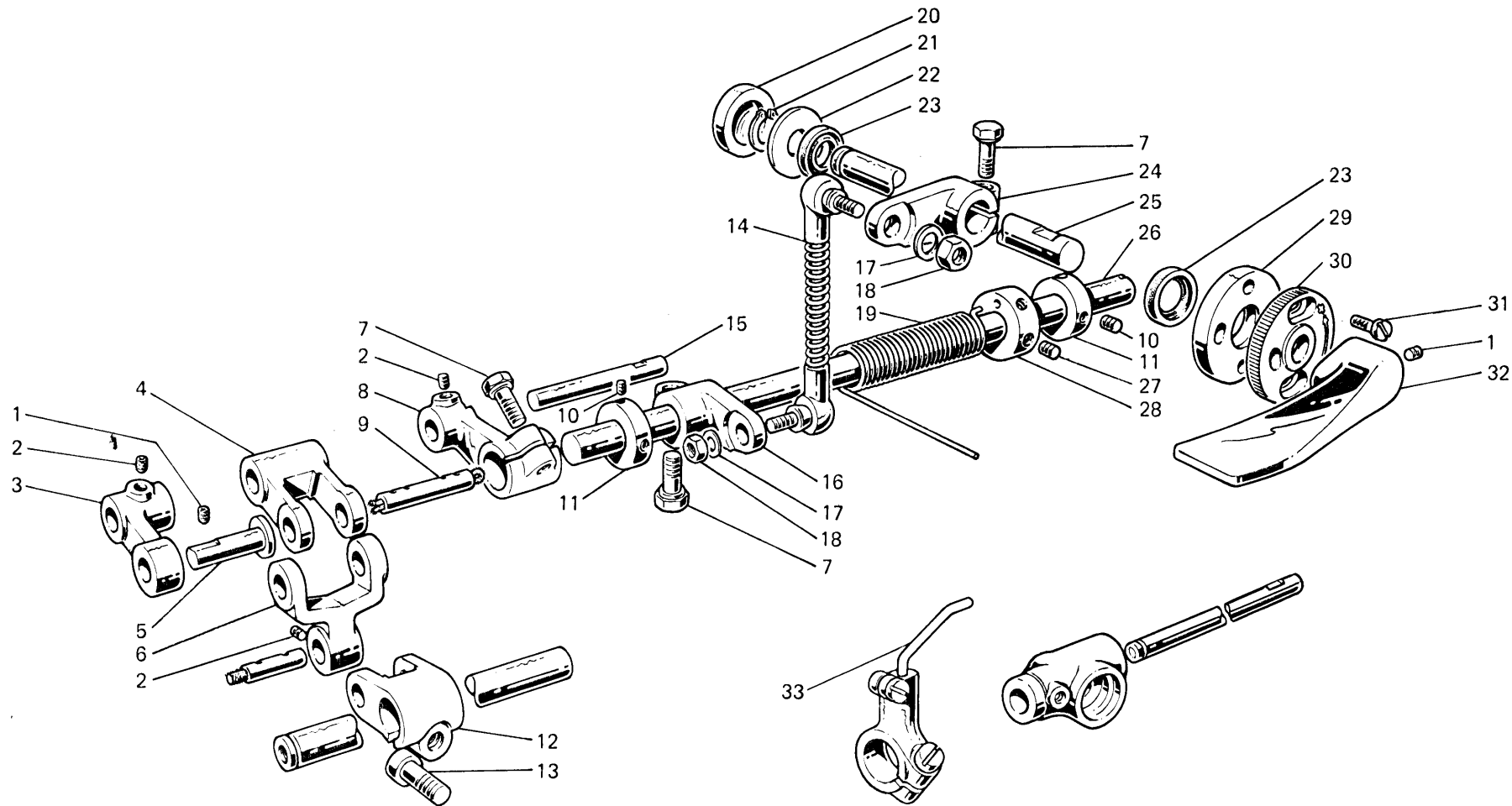

Fig. N. Abb. N.	Part. N. Bestell N. Piece N. Pieza N.	Qt. Anzahl	DESCRIZIONE	DESCRIPTION	DESCRIPTION	BENENNUNG	DESCRIPCION
1	729013-2-00	3	vite	screw	vis		
2	745811-2-00	3	vite	screw	vis		
3	311113-2-00	1	braccio con vite	arm with screw	bras avec vis		
4	311108-0-00	1	braccio oscillante	arm	bras		
5	311117-0-00	1	perno	pin	pivot		
6	311107-2-00	1	giunto con vite	joint with screw	joint avec vis		
7	202502-0-10	3	vite	screw	vis		
8	311112-2-00	1	braccio con vite	arm with screw	bras avec vis		
9	311250-2-00	1	perno con stoppini	pin with wicks	pivot avec mèches		
10	745812-2-00	4	vite	screw	vis		
11	206606-2-00	2	anello di registro con viti	adjustment ring with screws	bague d'étanchéité avec vis		
12	311110-2-00	1	braccio a forcella con vite	fork arm with screw	bras à fourche avec vis		
13	744332-2-00	1	vite	screw	vis		
14	311300-3-00	1	gruppo tirante	tie-rod assembly	groupe tirant		
15	311114-0-00	1	perno	pin	pivot		
16	311131-2-00	1	braccio con vite	arm with screw	bras avec vis		
17	704309-4-00	2	rondella	washer	rondelle		
18	746020-2-00	2	dado	nut	écrou		
19	311133-0-00	1	molla	spring	ressort		
20	311036-0-00	1	tappo	plug	bouchon		
21	700010-0-00	1	anello di fermo	spring ring	anneau ressort		
22	704240-2-00	1	rondella	washer	rondelle		
23	304763-0-10	2	anello di tenuta	retainer ring	bague d'étanchéité		
24	311135-2-00	1	braccio con vite	arm with screw	bras avec vis		
25	311128-0-00	1	perno	pin	pivot		
26	311115-0-00	1	albero	shaft	arbre		
27	729012-2-00	2	vite	screw	vis		
28	311134-2-00	1	anello con viti	ring with screws	anneau avec vis		
29	311132-0-00	1	flangia	flange	flasque		
30	311127-0-00	1	flangia limitatrice	flange	flasque		
31	741056-0-00	2	vite	screw	vis		
32	311126-2-00	1	tasto con viti	push-button with screws	touche avec vis		
33	924652-0-10	1	spingi asola	front needle guard	pare-boucle		
34	311053-2-00	1	PEZZI ANNULLATI braccio forcella con vite	CANCELLED PARTS fork arm with screws	PIECES ANNULEES bras fourche avec vis		

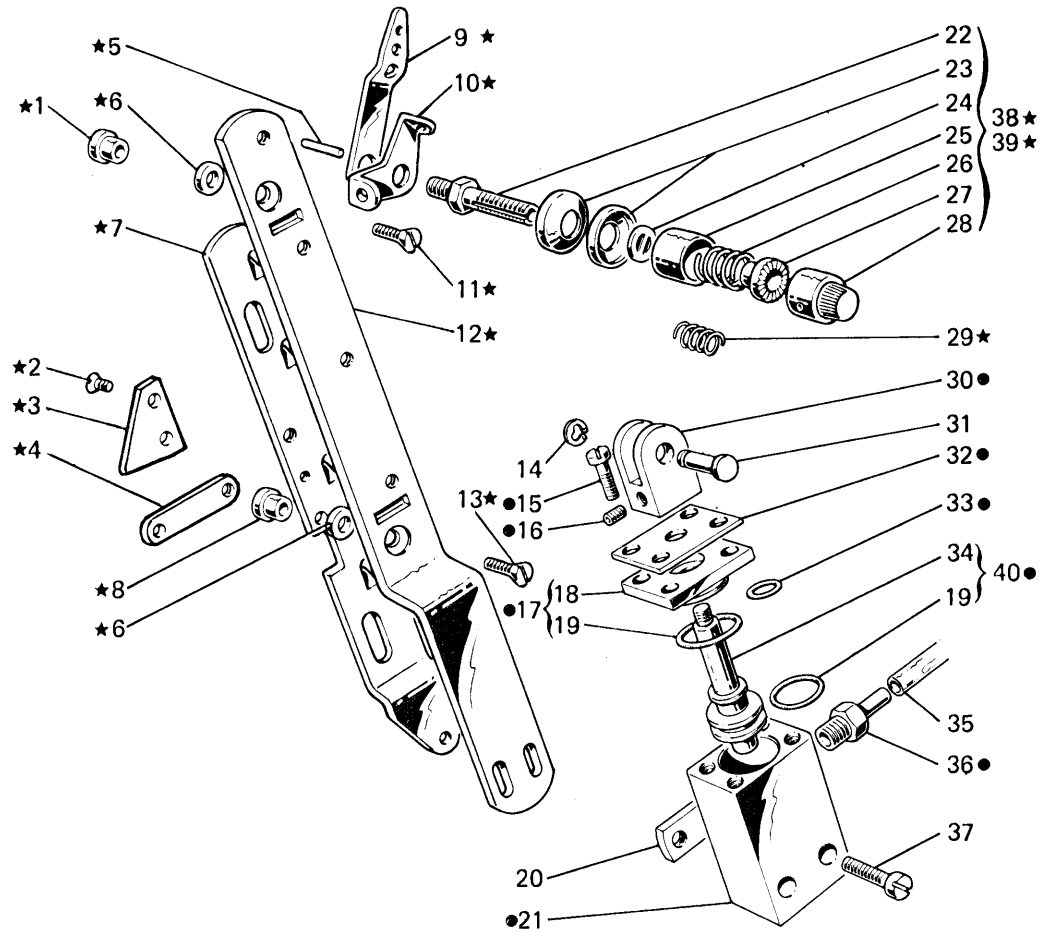

Fig. N. Abb. N.	Part. N. Bestell N. Piece N. Pieza N.	Qt. Anzahl	DESCRIZIONE	DESCRIPTION	DESCRIPTION	BENENNUNG	DESCRIPCION
★	924411-4-00	1	gruppo tensioni	tensions assembly	groupe tensions		
●	924735-4-11	1	valvola completa	valve assembly	soupape compl.		
1	924419-0-00	1	distanziale	spacer	entretoise		
2	724422-2-00	2	vite	screw	vis		
3	924417-0-00	1	piastrina	plate	plaque		
4	924418-0-00	1	piastrina	plate	plaque		
5	308506-0-00	3	pernetto	pin	pivot		
6	701007-0-00	2	anello	ring	anneau		
7	924416-0-00	1	slitta per tensione	slide for tension	glissière for tension		
8	308512-0-00	1	distanziale	spacer	entretoise		
9	308501-0-01	3	passafilo	thread guide	passe-fil		
10	308503-0-01	3	guidafilo	thread guide	guide-fil		
11	744696-2-00	1	vite	screw	vis		
12	926657-0-00	1	supporto	support	support		
13	744567-2-00	1	vite	screw	vis		
14	700205-0-00	1	anello elastico	spring ring	anneau ressort		
15	741495-0-00	4	vite	screw	vis		
16	745800-2-00	1	vite	screw	vis		
17	926669-4-00	1	flangia con anello di tenuta	flange	flasque		
18	924736-0-20	1	flangia	flange	flasque		
19	701009-0-00	2	anello di tenuta	retainer ring	anneau ressort		
20	924740-0-10	1	piastrina	plate	plaque		
21	924734-0-20	1	corpo	body	corps		
22	308505-0-00	3	perno a vite	threaded pin	pivot à vis		
23	300218-0-10	6	disco tensione	tension disc	disque tension		
24	308507-0-00	3	rondella	washer	rondelle		
25	202556-0-00	3	scodellino	cup	cuvette		
26	200710-0-10	2	molla	spring	ressort		
27	202229-0-10	3	bussola superiore	upper bush	bague supérieure		
28	202558-2-00	3	pomolo	knob	pommeau		
29	200714-0-10	1	molla	spring	ressort		
30	924739-0-10	1	forcella	fork	fourche		
31	202100-0-10	1	perno	pin	pivot		
32	924745-0-20	1	coperchio	cover	couvercle		
33	701104-0-00	1	anello di tenuta	retainer ring	anneau ressort		
34	924737-0-20	1	pistone	piston	piston		
35	790420-0-00	2	tubetto	pipe	tube		
36	924701-0-10	2	attacco per tubetto	pipe union	raccord pour tube		
37	721086-2-00	2	vite	screw	vis		
38	308518-4-00	2	tensione sup. con molla fig. 26	upper tension with spring fig. 26	tension sup. avec ressort fig. 26		
39	308521-4-00	1	tensione inf. con molla fig. 29	lower tension with spring fig. 29	tension inf. avec ressort fig. 29		
40	924738-4-20	1	pistone con anello di tenuta	piston with retainer ring	piston avec bague d'étanchéité		

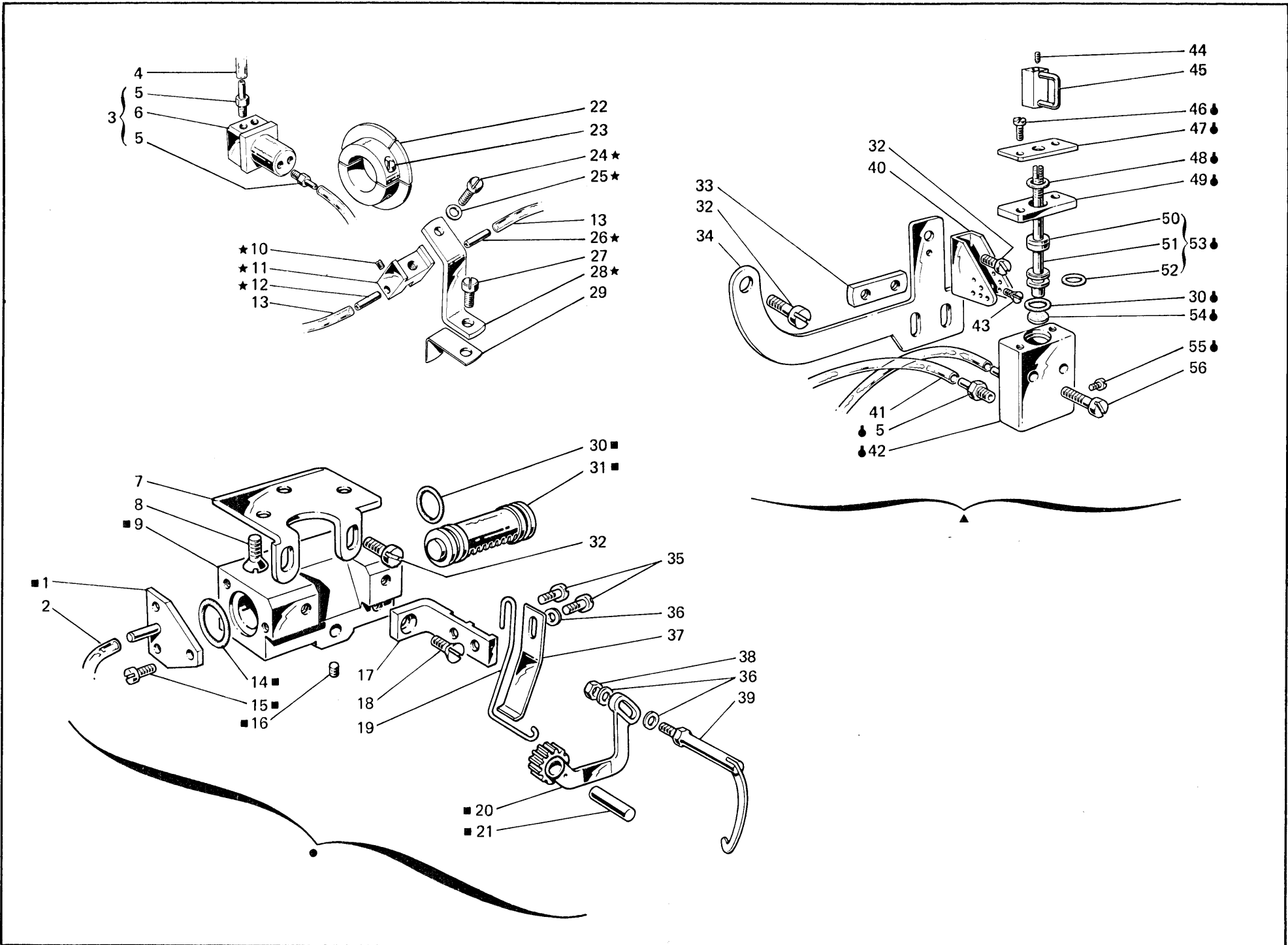

Fig. N. Abb. N.	Part. N. Bestell N. Piece N. Pieza N.	Qt. Anzahl	DESCRIZIONE	DESCRIPTION	DESCRIPTION	BENENNUNG	DESCRIPCION
★	924176-4-00	1	gruppo sensore fluidico	sensor group	groupe senseur		
●	924350-5-10	1	appinzatore completo (escluso figg. 2-7-8-32)	gripping device assembly (excluded figs. 2-7-8-32)	dispositif pinceur complet (exclu figg. 2-7-8-32)		
■	924384-4-10	1	cilindro completo	cylinder assembly	cylindre complet		
▲	924723-5-10	1	tirafilo completo (escluso figg. 32-41)	thread take-up assembly (excluded figs. 32-41)	tendeur du fil complet (exclu figg. 32-41)		
⚙	924722-4-11	1	valvola completa	valve assembly	soupape complet		
1	924387-2-00	2	coperchio con raccordo	cover with pipe connection	couvercle avec raccord		
2	790417-0-00	2	tubetto	pipe	tube		
3	924172-4-00	1	tappo completo	plug	bouchon		
4	790407-0-00	2	tubetto	pipe	tube		
5	924701-0-11	6	attacco	pipe union	raccord		
6	924173-0-00	1	tappo	plug	bouchon		
7	924355-0-00	1	squadretta	bracket	équerre		
8	725612-2-00	3	vite	screw	vis		
9	924351-0-10	1	corpo	body	corps		
10	727012-0-00	2	vite	screw	vis		
11	924178-0-00	1	blocchetto	block	bloc		
12	924179-0-00	1	tubetto	pipe	tube		
13	790405-0-00	2	tubetto	pipe	tube		
14	701017-0-00	2	anello di tenuta	retainer ring	bague d'étanchéité		
15	741634-0-00	6	vite	screw	vis		
16	745800-2-00	1	vite	screw	vis		
17	924352-0-00	1	supporto	support	support		
18	724441-0-00	1	vite	screw	vis		
19	924353-0-10	1	molla	spring	ressort		
20	924369-2-10	1	leva con pignone	lever with pinion	levier avec pignon		
21	924356-0-10	1	perno	pin	pivot		
22	924175-2-00	1	disco con viti	disc with screws	disque avec vis		
23	924579-0-00	2	vite	screw	vis		
24	741558-0-00	1	vite	screw	vis		
25	704104-2-00	1	rondella	washer	rondelle		
26	924180-0-00	1	tubetto	pipe	tube		
27	721444-2-00	1	vite	screw	vis		
28	924177-0-00	1	supporto	support	support		
29	924181-0-00	1	squadretta	bracket	équerre		
30	701009-0-00	3	anello di tenuta	retainer ring	bague d'étanchéité		
31	924367-2-10	1	pistone con anelli di tenuta	piston with retainer ring	piston avec bague d'étanchéité		
32	741936-0-00	4	vite	screw	vis		
33	924730-0-10	1	piastrina	plate	plaque		
34	924727-0-10	1	sostegno	support	support		
35	741634-0-00	2	vite	screw	vis		
36	704302-4-00	3	rondella	washer	rondelle		
37	924354-0-00	1	lamina	sheet	plaque		
38	746002-2-00	1	dado	nut	écrou		
39	924366-2-10	1	gancio	hook	crochet		
40	924729-0-10	1	passafilo	thread guide	passe-fil		
41	790408-0-00	2	tubetto	pipe	tube		

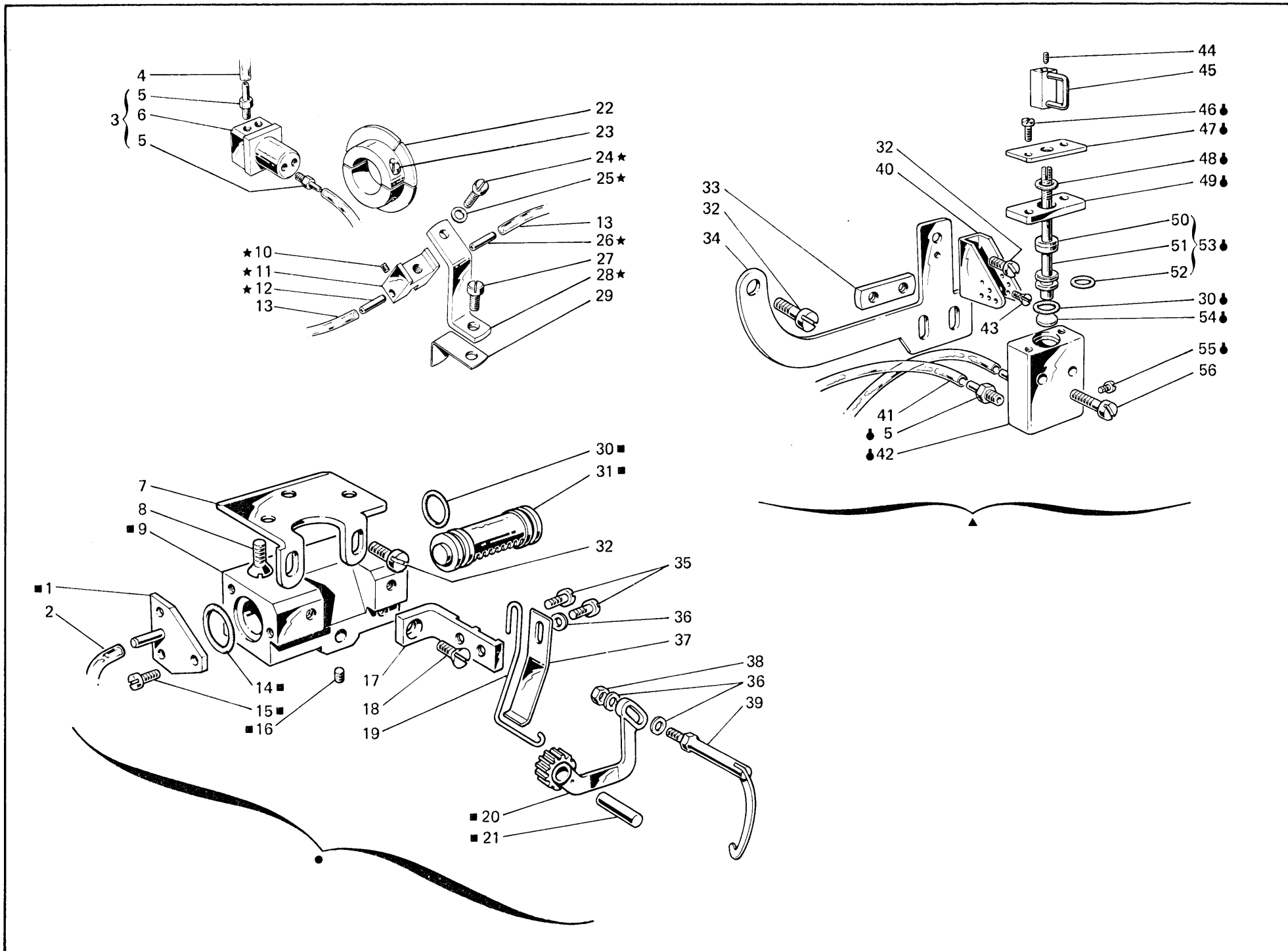

Fig. N. Abb. N.	Part. N. Bestell N. Piece N. Pieza N.	Qt. Anzahl	DESCRIZIONE	DESCRIPTION	DESCRIPTION	BENENNUNG	DESCRIPCION
42	924721-0-10	1	corpo	body	corps		
43	724411-0-00	1	vite	screw	vis		
44	730041-2-00	1	vite	screw	vis		
45	924980-2-00	1	tendifilo	thread take-up	tendeur du fil		
46	741495-0-00	2	vite	screw	vis		
47	924733-0-10	1	coperchietto	cover	couvercle		
48	701002-0-00	1	anello di tenuta	retainer ring	bague d'étanchéité		
49	924726-0-10	1	coperchio	cover	couvercle		
50	924731-0-10	1	ammortizzatore	damper	amortisseur		
51	924724-0-11	1	pistoncino	piston	piston		
52	701104-0-00	1	anello di tenuta	retainer ring	bague d'étanchéité		
53	924725-4-11	1	pistoncino completo	piston assembly	piston complet		
54	924732-0-10	1	ammortizzatore	damper	amortisseur		
55	741405-4-00	3	tappo a vite	plug	bouchon		
56	721514-0-00	2	vite	screw	vis		

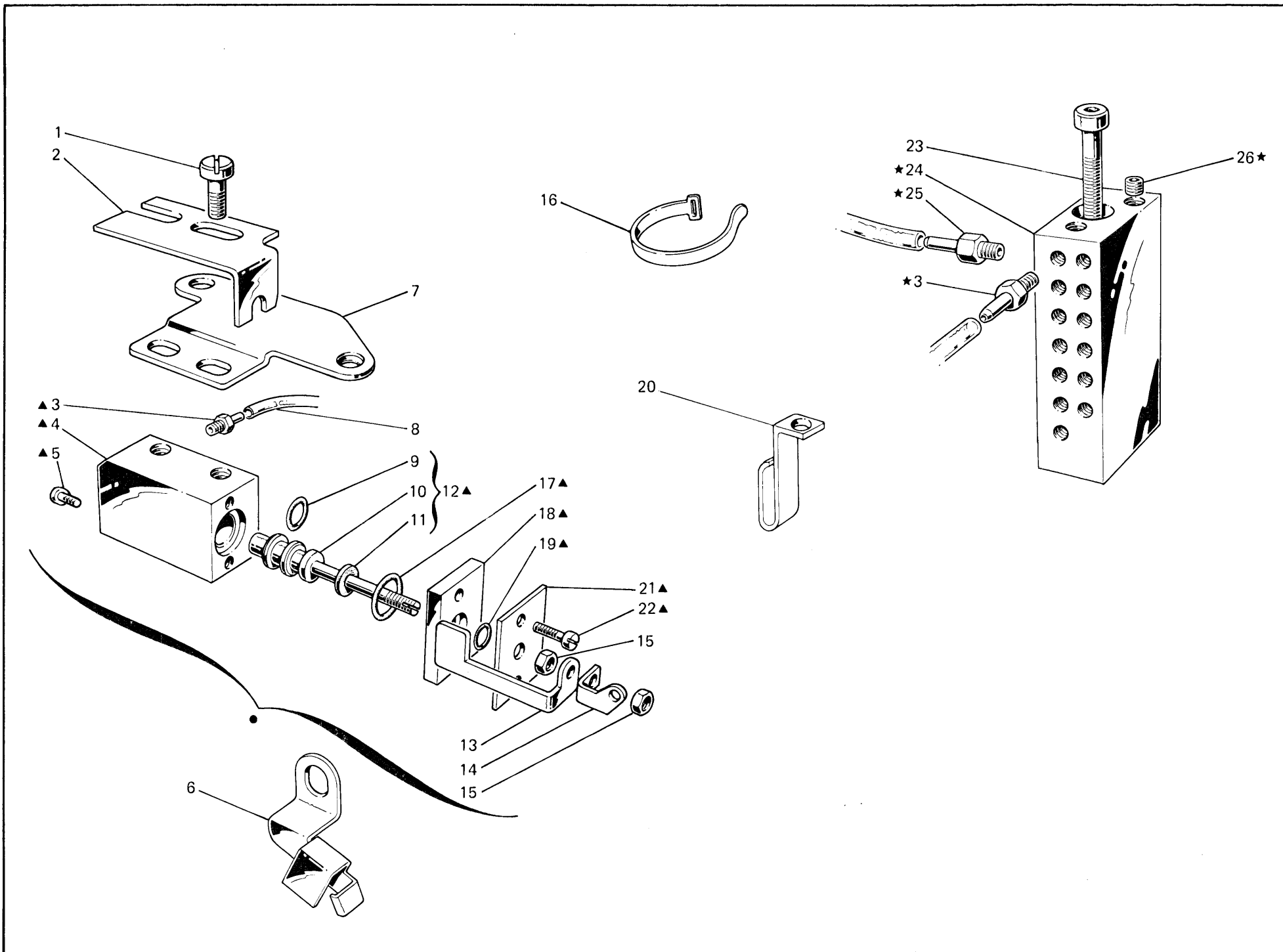

Fig. N. Abb. N.	Part. N. Bestell N. Piece N. Pieza N.	Qt. Anzahl	DESCRIZIONE	DESCRIPTION	DESCRIPTION	BENENNUNG	DESCRIPCION
●	924385-4-00	1	gruppo tirafilo	thread take-up assembly	groupe tendeur du fil		
▲	924684-4-11	1	valvola completa	valve assembly	soupape complète		
★	924162-4-00	1	distributore completo	distributeur assembly	distributeur complet		
1	741956-2-00	2	vite	screw	vis		
2	924693-0-11	1	squadretta	bracket	équerre		
3	924701-0-11	15	attacco	pipe union	raccord		
4	924683-0-11	1	corpo	body	corps		
5	741405-4-00	2	tappo a vite	plug	bouchon		
6	924480-0-00	1	supporto per tubetti	support for pipe	support pour tube		
7	924483-0-00	1	supporto	support	support		
8	790410-0-00	2	tubetto	pipe	tube		
9	701104-0-00	1	anello di tenuta	retainer ring	bague d'étanchéité		
10	924724-0-11	1	pistoncino	piston	piston		
11	924731-0-10	1	ammortizzatore	damper	amortisseur		
12	924725-4-11	1	pistoncino completo	piston assembly	piston complet		
13	924485-0-00	1	asta	rod	tige		
14	924484-0-00	1	tirafilo	thread take-up	tendeur du fil		
15	746002-2-00	2	dado	nut	écrou		
16	920258-0-10	2	cinturino	strap	bride		
17	701007-0-00	1	anello di tenuta	retainer ring	bague d'étanchéité		
18	924686-0-10	1	flangia	flange	flasque		
19	701002-0-00	1	anello di tenuta	retainer ring	bague d'étanchéité		
20	924497-0-00	1	fascetta	clamp	bride		
21	924692-0-10	1	coperchio	cover	couvercle		
22	741495-0-00	2	vite	screw	vis		
23	722583-2-00	1	vite	screw	vis		
24	924160-0-00	1	distributore	distributor	distributeur		
25	924797-0-10	5	attacco	pipe union	raccord		
26	745815-2-00	2	vite	screw	vis		

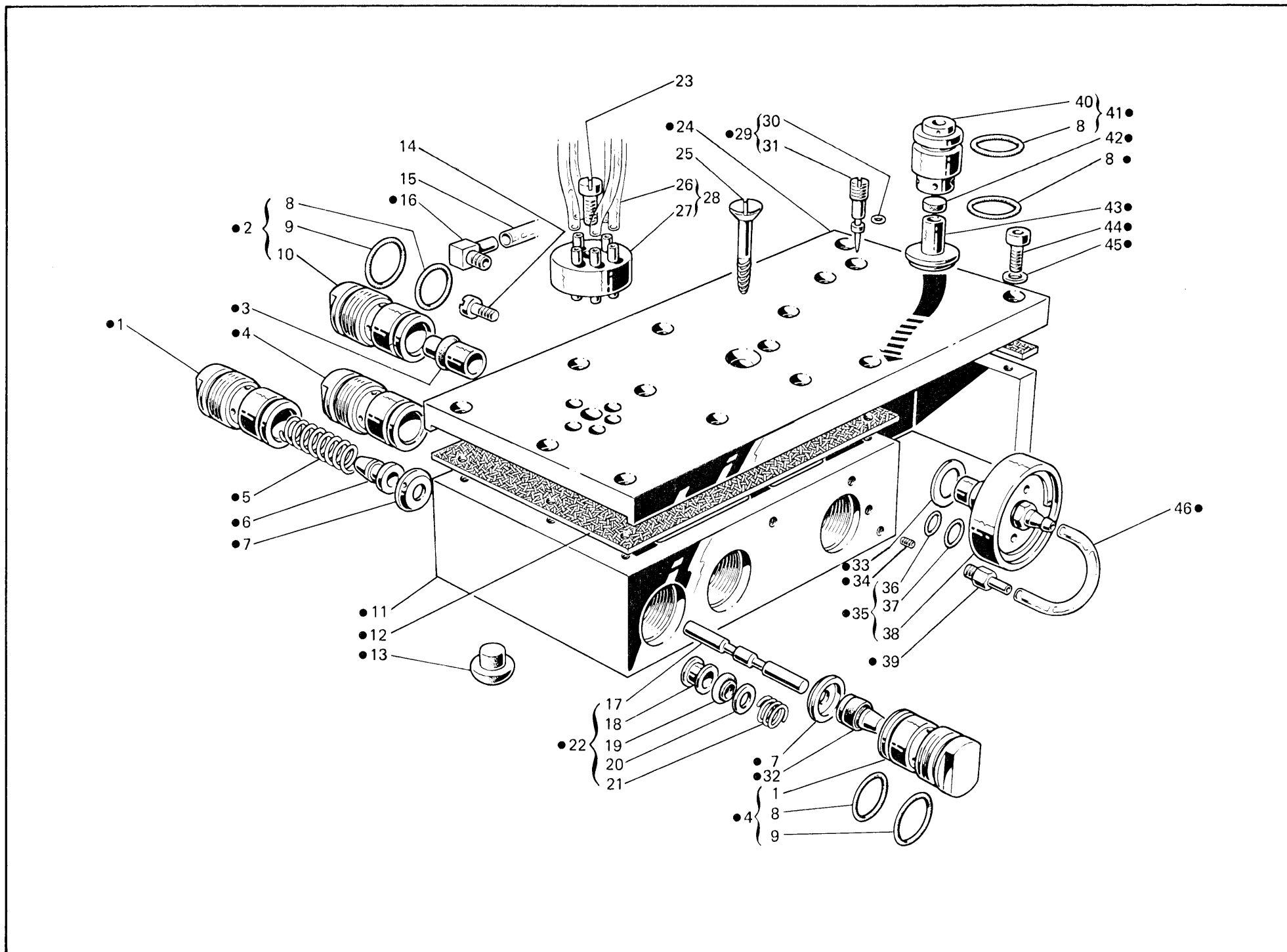
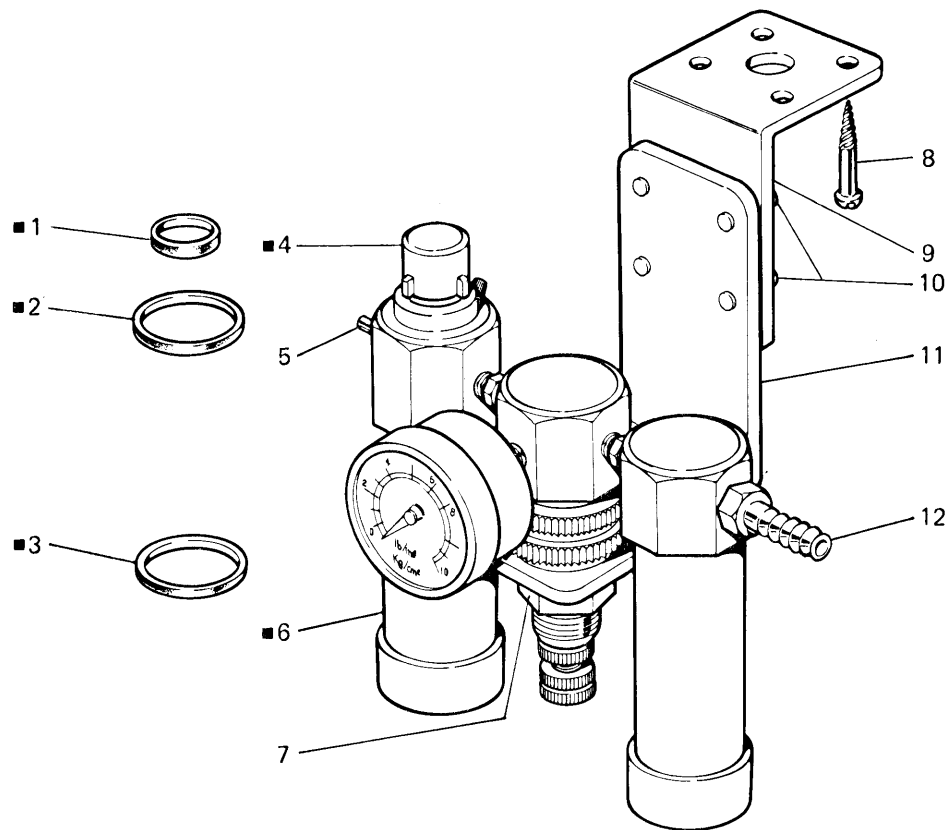

Fig. N. Abb. N.	Part. N. Bestell N. Piece N. Pieza N.	Qt. Anzahl	DESCRIZIONE	DESCRIPTION	DESCRIPTION	BENENNUNG	DESCRIPCION
●	924195-5-00	1	centralina completa	distributor assembly	distributeur complet		
1	924200-0-00	5	coperchio	cover	couvercle		
2	924216-4-00	1	coperchio con anello di tenuta	cover with retainer ring	couvercle avec bague d'étanchéité		
3	924214-4-00	1	pistone con guarnizione	piston with gasket	piston avec garniture		
4	924201-4-00	4	coperchio con anelli di tenuta	cover with retainer ring	couvercle avec bague d'étanchéité		
5	924202-0-00	1	molla	spring	ressort		
6	924203-0-00	1	pistone	piston	piston		
7	924206-0-00	6	distanziale	spacer	entretoise		
8	701023-0-00	7	anello di tenuta	retainer ring	bague d'étanchéité		
9	701120-0-00	5	anello di tenuta	retainer ring	bague d'étanchéité		
10	924215-0-00	1	coperchio	cover	couvercle		
11	924196-0-00	1	corpo	body	corps		
12	924198-0-00	1	guarnizione	gasket	garniture		
13	922797-0-00	3	gommino	dumper	caoutchouc		
14	741156-2-00	2	vite	screw	vis		
15	790051-0-00	1	tubetto	pipe	tube		
16	926409-0-00	1	raccordo	pipe connection	raccord		
17	924207-0-00	3	pistone	piston	piston		
18	924209-0-00	12	distanziale	spacer	entretoise		
19	924208-0-00	18	guarnizione	gasket	garniture		
20	924210-0-00	6	rondella	washer	rondelle		
21	924211-0-00	3	molla	spring	ressort		
22	924232-3-00	3	pistone completo	piston assembly	piston complet		
23	741177-0-00	1	vite	screw	vis		
24	924197-0-00	1	piastra di copertura	cover plate	plaque de couverture		
25	731367-0-00	1	vite da legno	screw	vis		
26	790507-0-00	5	tubetto	pipe	tube		
27	924168-2-00	1	disco	disc	disque		
28	924170-4-00	1	disco completo	disc assembly	disque complet		
29	924218-4-00	1	vite con anello di tenuta	screw with retainer ring	vis avec bague d'étanchéité		
30	701000-0-00	1	anello di tenuta	retainer ring	bague d'étanchéité		
31	924217-0-00	1	vite	screw	vis		
32	924205-4-00	4	pistone con guarnizione	piston with gasket	piston avec garniture		
33	703814-0-00	1	rondella	washer	rondelle		
34	729012-2-00	9	vite	screw	vis		
35	924223-4-00	1	valvola completa	valve assembly	soupape complète		
36	701007-0-00	1	anello di tenuta	retainer ring	bague d'étanchéité		
37	701011-0-00	1	anello di tenuta	retainer ring	bague d'étanchéité		
38	924222-0-00	1	valvola	valve	soupape		
39	924797-0-10	1	attacco	pipe union	raccord		
40	924219-0-00	1	coperchio	cover	couvercle		
41	924220-4-00	1	coperchio con anello di tenuta	cover with retainer ring	couvercle avec bague d'étanchéité		
42	923821-0-00	1	pastiglia	plug	bouchon		
43	924221-0-00	1	bussola inferiore	lower bush	bague inférieure		
44	722431-2-00	14	vite	screw	vis		
45	703005-0-00	14	rondella	washer	rondelle		
46	790502-0-00	1	tubetto	pipe	tube		



★

Fig. N. Abb. N.	Part. N. Bestell N. Pieza N.	Qt. Anzahl	DESCRIZIONE	DESCRIPTION	DESCRIPTION	BENENNUNG	DESCRIPCION
★	926448-4-00	1	gruppo controllo aria (escluso fig. 8)	air control assembly (excluded fig. 8)	groupe contrôle aire (exclu fig. 8)		
■	925772-4-00	1	gruppo filtro	filter assembly	groupe filtre		
1	924994-0-00	1	guarnizione	gasket	garniture		
2	924991-0-00	2	guarnizione	gasket	garniture		
3	924990-0-00	2	guarnizione	gasket	garniture		
4	924993-0-00	1	cappello	cap	capuchon		
5	926303-0-00	1	attacco	pipe union	raccord pour tube		
6	924992-0-00	2	tazza	container	tasse		
7	924818-0-10	1	dado	nut	écrou		
8	731085-0-00	4	vite da legno	screw	vis		
9	925513-0-00	1	squadretta	bracket	équerre		
10	721444-2-00	4	vite	screw	vis		
11	924817-0-10	1	squadretta	bracket	équerre		
12	923804-0-00	1	attacco	pipe union	raccord pour tube		

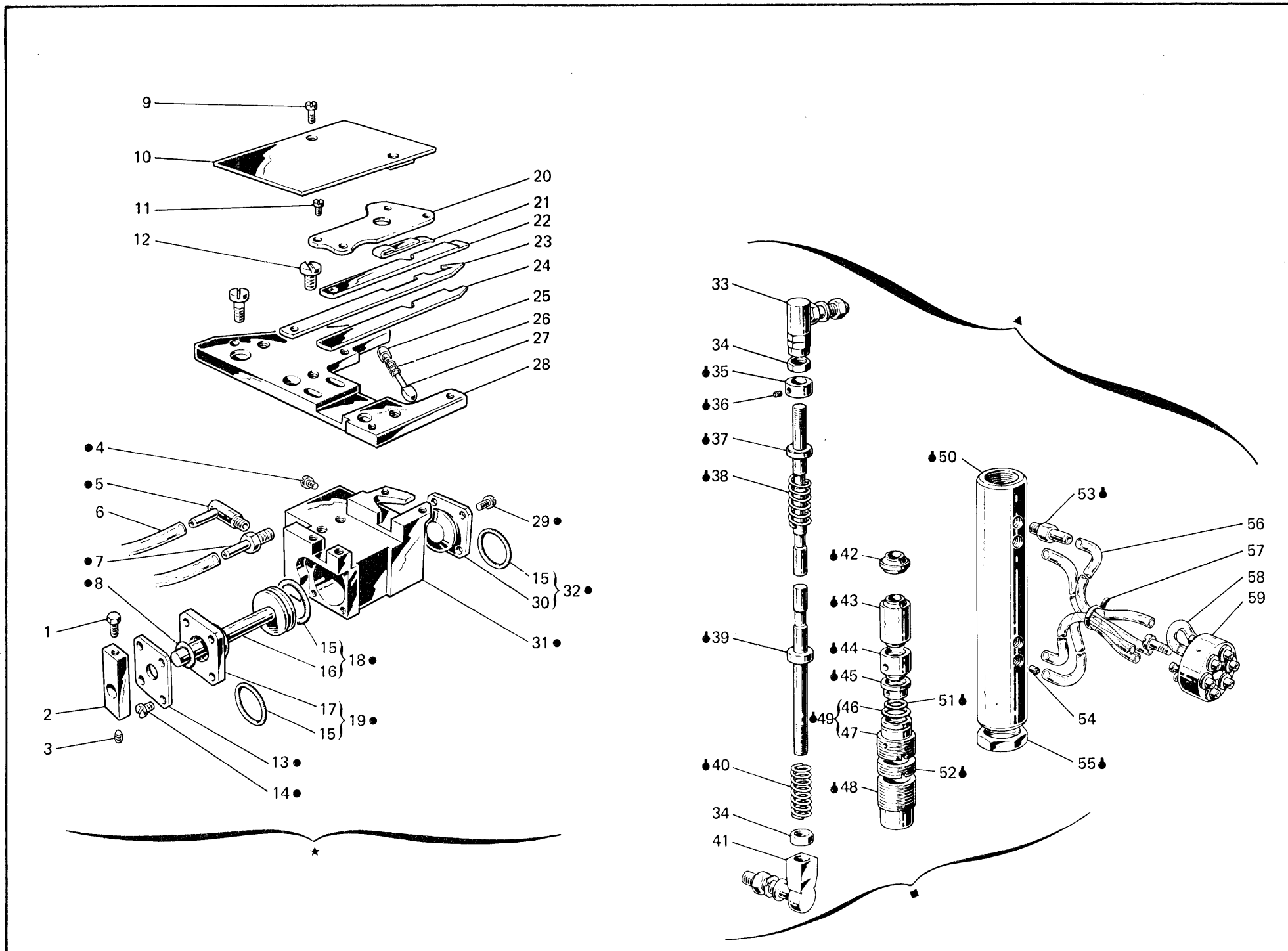

Fig. N. Abb. N.	Part. N. Piece N. Bestell N. Pieza N.	Qt. Anzahl	DESCRIZIONE	DESCRIPTION	DESCRIPTION	BENENNUNG	DESCRIPCION
★	924390-5-00	1	gruppo pistoncino (escluso figg.6 - 9 -10)	piston assembly (excluded figs.6 - 9 -10)	groupe piston (exclu fig.6 - 9 -10)		
●	924391-4-00	1	pistoncino completo	piston assembly	piston complet		
▲	924228-4-00	1	gruppo valvola	valve assembly	groupe soupape		
■	924787-5-10	1	valvola completa con giunti	valve assembly with joint	soupape complète avec joint		
◆	924786-4-10	1	valvola completa	valve assembly	soupape complète		
1	924673-0-10	1	vite	screw	vis		
2	924668-0-10	1	fascetta	clamp	bride		
3	730011-2-00	1	vite	screw	vis		
4	741405-4-00	1	tappo a vite	plug	bouchon		
5	924392-0-00	1	attacco	pipe union	raccord		
6	790421-0-00	2	tubetto	pipe	tube		
7	924393-0-00	1	attacco	pipe union	raccord		
8	701008-0-00	1	anello di tenuta	retainer ring	bague d'étanchéité		
9	741913-4-00	2	vite	screw	vis		
10	924471-2-00	1	carterino	cover	carter		
11	744530-0-00	4	vite	screw	vis		
12	741956-2-00	2	vite	screw	vis		
13	924663-0-10	1	coperchio	cover	couvercle		
14	741461-0-00	4	vite	screw	vis		
15	701009-0-00	3	anello di tenuta	retainer ring	bague d'étanchéité		
16	924659-0-10	1	pistoncino	piston	piston		
17	924661-0-10	1	flangia	flange	flasque		
18	924660-4-10	1	pistoncino completo	piston assembly	piston complet		
19	924662-4-10	1	flangia completa	flange assembly	flasque complète		
20	924667-0-11	1	piastrina	plate	plaque		
21	924672-0-10	1	molla	spring	ressort		
22	924671-0-10	1	coltello superiore	upper knife	couteau supérieur		
23	924670-0-10	1	coltello	knife	couteau		
24	924669-0-10	1	lama inferiore	lower sheet	plaque inférieure		
25	924675-0-10	1	fulcro	fulcrum	pivot		
26	100893-0-09	1	molla	spring	ressort		
27	924674-0-10	1	perno	pin	pivot		
28	924472-2-00	1	piastra	plate	plaque		
29	741431-0-00	4	vite	screw	vis		
30	924664-0-11	1	flangia	flange	flasque		
31	924656-0-11	1	corpo	body	corps		
32	924665-4-11	1	flangia completa	flange assembly	flasque complète		
33	900941-0-00	1	giunto superiore	upper joint	joint supérieur		
34	746203-4-00	2	dado	nut	écrou		
35	924795-0-10	1	anello	ring	anneau		
36	745812-2-00	1	vite	screw	vis		
37	924794-0-10	1	pistoncino superiore	upper piston	piston supérieur		
38	302119-0-10	1	molla	spring	ressort		
39	924793-0-10	1	pistoncino inferiore	lower piston	piston inférieur		
40	203909-0-11	1	molla	spring	ressort		
41	900942-0-00	1	giunto inferiore	lower joint	joint inférieur		
42	924798-0-10	1	distanziale	spacer	entretoise		

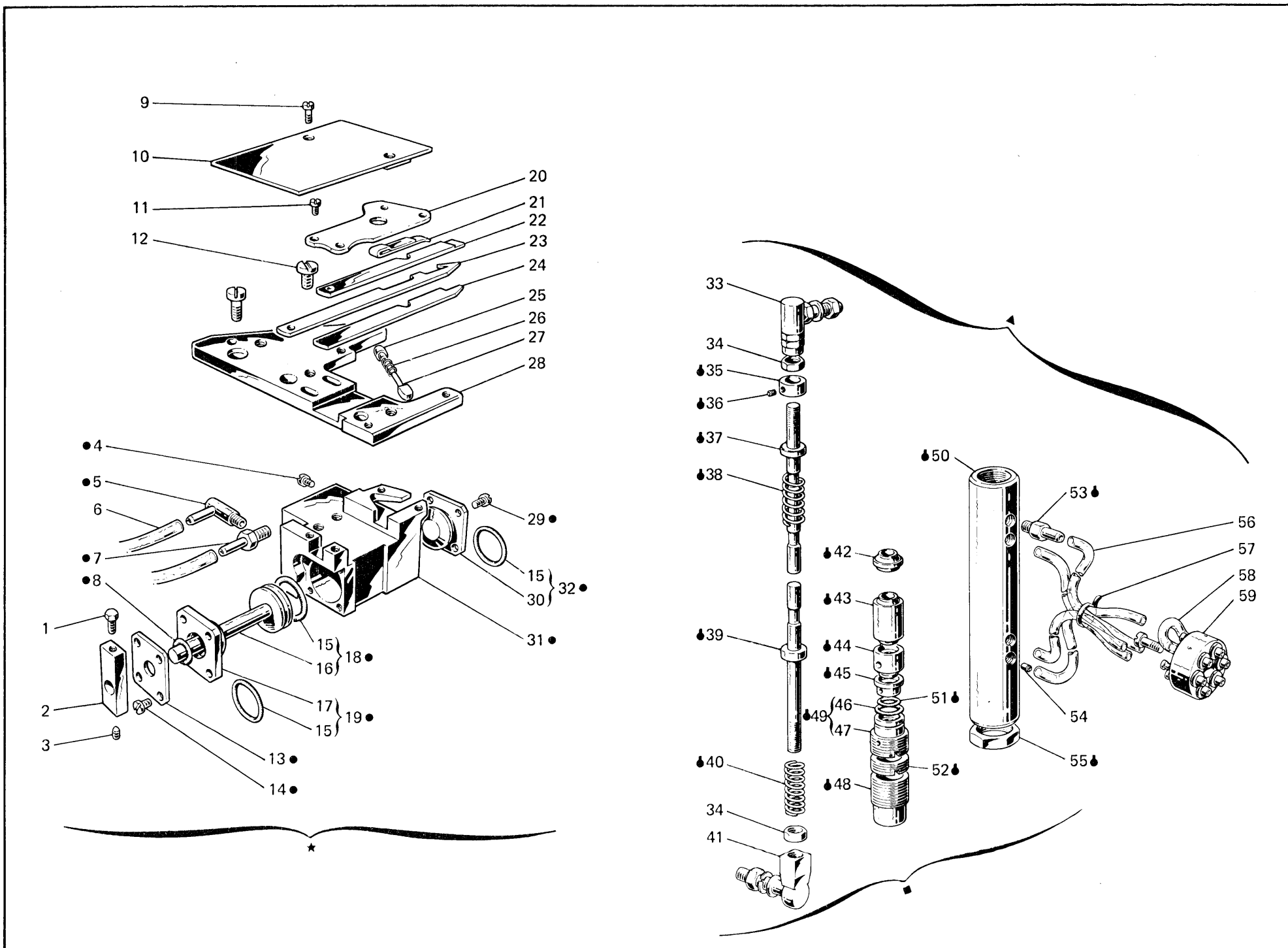

Fig. N. Abb. N.	Part. N. Piece N. Bestell N. Pieza N.	Qt. Anzahl	DESCRIZIONE	DESCRIPTION	DESCRIPTION	BENENNUNG	DESCRIPCION
43	924792-0-10	1	bussola	bush	bague		
44	924791-0-10	2	distanziale	spacer	entretoise		
45	924799-0-10	3	distanziale	spacer	entretoise		
46	701113-0-00	7	anello di tenuta	retainer ring	bague d'étanchéité		
47	924788-0-10	2	ghiera	ring nut	collier		
48	924790-0-10	2	tappo	plug	bouchon		
49	924789-4-10	2	ghiera	ring nut	collier		
50	924785-0-10	1	cilindro	cylinder	cyindre		
51	701005-0-00	8	anello di tenuta	retainer ring	bague d'étanchéité		
52	924800-0-11	1	ghiera	ring nut	collier		
53	924797-0-10	4	attacco	pipe union	raccord		
54	924227-0-00	1	riduttore	reduction unit	réducteur		
55	924796-0-10	2	dado	nut	écrou		
56	790547-0-00	4	tubetto	pipe	tube		
57	920258-0-10	3	cinturino	strap	bride		
58	790504-0-00	1	tubetto	pipe	tube		
59	924169-2-00	1	disco	disc	disque		

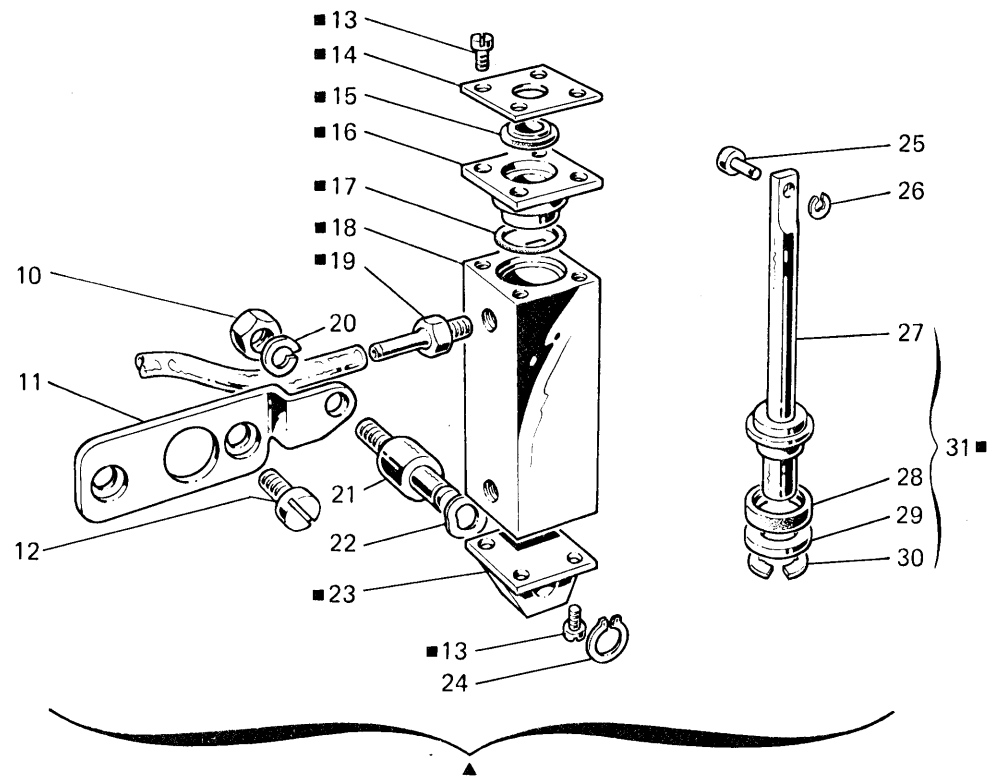
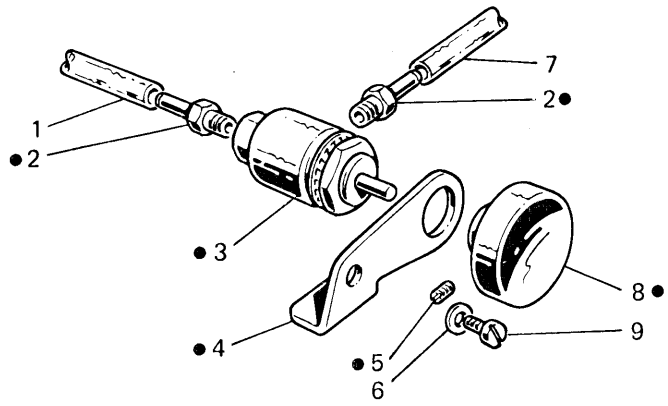

Fig. N. Abb. N.	Part. N. Bestell N. Piece N. Pieza N.	Qt. Anzahl	DESCRIZIONE	DESCRIPTION	DESCRIPTION	BENENNUNG	DESCRIPCION
●	925511-4-00	1	minivalvola completa	valve assembly	soupape complète		
▲	924381-4-00	1	gruppo pistone (escluso figg.7-12-25-26)	piston assembly (excluded figs.7-12-25-26)	groupe piston (exclu figs.7-12-25-26)		
■	924382-4-00	1	pistone completo	piston assembly	piston complet		
1	790413-0-00	1	tubetto	pipe	tube		
2	924784-0-10	2	attacco	pipe union	raccord pour tube		
3	924780-0-10	1	minivalvola	valve	soupape		
4	925510-0-00	1	supporto	support	support		
5	727032-0-00	1	vite	screw	vis		
6	704210-4-00	1	rondella	washer	rondelle		
7	790436-0-00	1	tubetto	pipe	tube		
8	924782-0-10	1	pomolo	knob	pommeau		
9	741937-0-00	1	vite	screw	vis		
10	746402-0-00	1	dado	nut	écrou		
11	924383-0-00	1	piastra	plate	plaque		
12	742214-2-00	2	vite	screw	vis		
13	741552-0-00	8	vite	screw	vis		
14	926265-0-00	1	coperchietto	cover	couvercle		
15	923828-4-00	1	anello di tenuta	retainer ring	baque d'étanchéité		
16	926266-0-01	1	flangia	flange	flasque		
17	701023-0-00	1	anello di tenuta	retainer ring	baque d'étanchéité		
18	926257-0-00	1	cilindro	cylinder	cylindre		
19	924380-0-00	1	attacco	pipe union	raccord pour tube		
20	703007-0-00	1	rondella elastica	spring washer	rondelle élastique		
21	926268-0-00	1	perno	pin	pivot		
22	926329-0-00	1	anello elastico	spring ring	anneau ressort		
23	926264-0-00	1	coperchio posteriore	rear cover	couvercle arrière		
24	700207-0-00	1	anello elastico	spring ring	anneau ressort		
25	203847-0-10	1	perno	pin	pivot		
26	700205-0-00	1	anello elastico	spring ring	anneau ressort		
27	926258-0-00	1	pistone	piston	piston		
28	926309-4-00	1	anello di tenuta	retainer ring	anneau d'étanchéité		
29	926267-0-00	1	rondella	washer	rondelle		
30	700209-0-00	1	anello elastico	spring ring	anneau ressort		
31	926259-4-00	1	pistone(con figg.27-28-29-30)	piston(with figs.27-28-29-30)	piston(avec figs.27-28-29-30)		

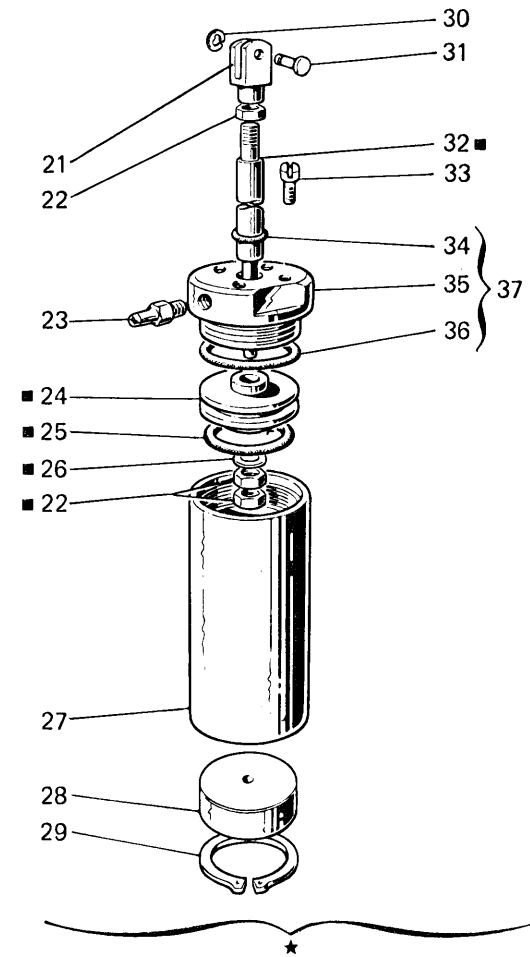
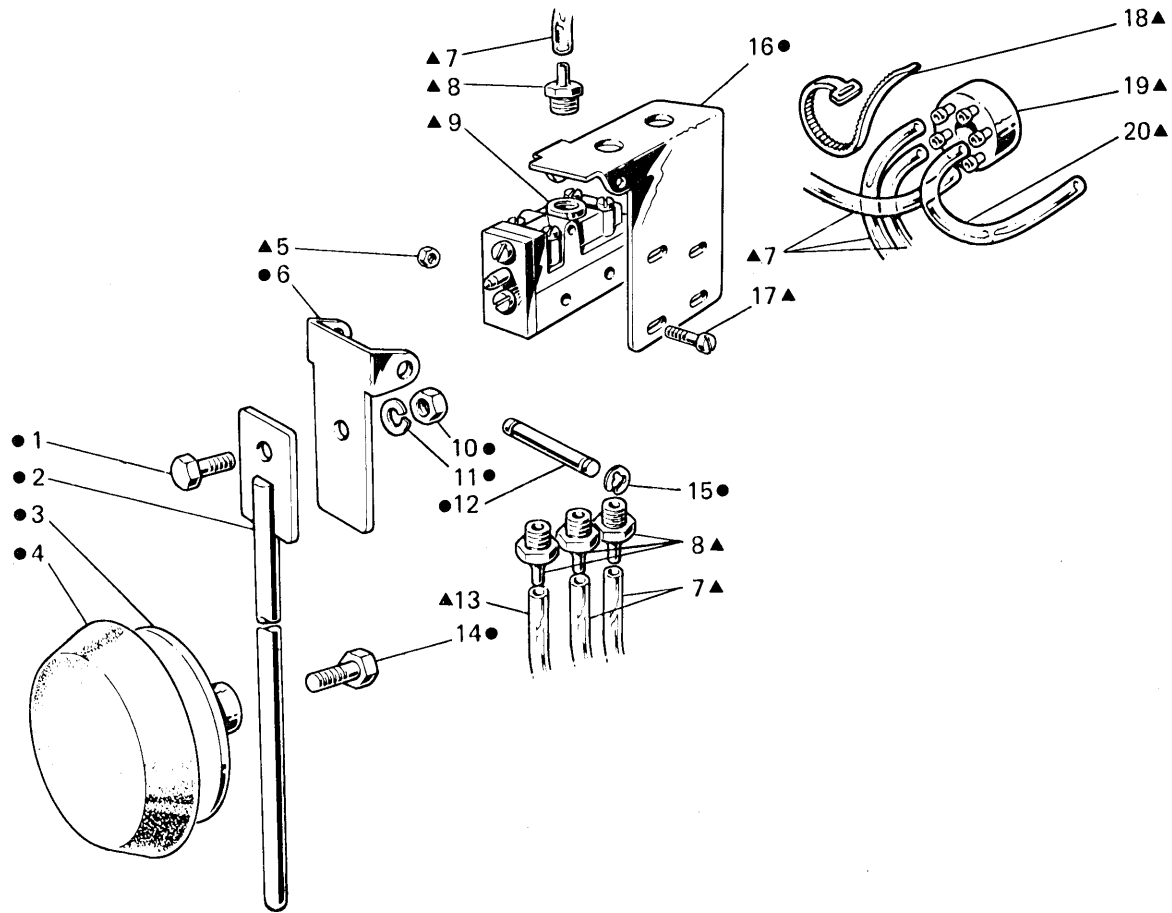

Fig. N. Abb. N.	Part. N. Bestell N. Piece N. Pieza N.	Qt. Anzahl	DESCRIZIONE	DESCRIPTION	DESCRIPTION	BENENNUNG	DESCRIPCION
▲	924230-4-00	1	gruppo ginocchiello (con ●)	knee-press group (with ●)	groupe genouillère (avec ●)		
—	924861-4-10	1	ginocchiello con attacchi (● con figg. 5-8-9-17)	knee-press with pipe union (● with figs. 5-8-9-17)	genouillère avec raccord (● avec fig. 5-8-9-17)		
●	924864-4-10	1	ginocchiello completo	knee-press assembly	genouillère complète		
★	924408-4-00	1	gruppo pistone (escluso figg. 31-32-34)	piston group (excluded figs. 31-32-34)	groupe piston (exclu fig. 31-32-34)		
■	924805-4-10	1	pistone completo	piston assembly	piston complet		
1	720464-2-00	1	vite	screw	vis		
2	924866-2-10	1	asta	rod	tige		
3	920105-0-10	1	disco	disc	disque		
4	920113-0-10	1	cuscino	pad	coussin		
5	733505-0-00	3	dado	nut	écrou		
6	924863-0-10	1	piastra mobile	movable plate	plaque mobile		
7	790547-0-00	3	tubetto	pipe	tube		
8	924870-0-10	4	attacco	pipe union	raccord		
9	924869-0-10	1	valvola	valve	soupape		
10	746203-4-00	1	dado	nut	écrou		
11	703008-0-00	1	rondella	washer	rondelle		
12	924868-0-10	1	perno	pin	pivot		
13	790537-0-00	1	tubetto	pipe	tube		
14	740035-0-00	1	vite	screw	vis		
15	700207-0-00	2	anello elastico	spring ring	anneau ressort		
16	924860-0-10	1	piastra	plate	plaque		
17	722153-0-00	3	vite	screw	vis		
18	920258-0-10	3	cinturino	strap	bride		
19	924167-2-00	1	disco completo	disc assembly	disque complet		
20	790522-0-00	1	tubetto	pipe	tube		
21	990310-0-10	1	forcella	fork	fourche		
22	746402-0-00	3	dado	nut	écrou		
23	924797-0-10	1	attacco	pipe union	raccord		
24	924804-0-10	1	pistone	piston	piston		
25	701037-0-00	1	anello di tenuta	retainer ring	bague d'étanchéité		
26	704218-2-00	1	rondella	washer	rondelle		
27	924802-0-10	1	cilindro	cylinder	cylindre		
28	924407-0-00	1	tappo inferiore	lower plug	bouchon inférieur		
29	700130-0-00	1	anello elastico	spring ring	anneau ressort		
30	700205-0-00	1	anello elastico	spring ring	anneau ressort		
31	990311-0-10	1	perno	pin	pivot		
32	924808-0-10	1	albero	shaft	arbre		
33	721474-2-00	3	vite	screw	vis		
34	701007-0-00	1	anello di tenuta	retainer ring	bague d'étanchéité		
35	924806-0-10	1	tappo superiore	upper shaft	bouchon supérieur		
36	701132-0-00	1	anello di tenuta	retainer ring	bague d'étanchéité		
37	924807-4-10	1	tappo superiore compl.	upper plug assembly	bouchon supérieur complet		

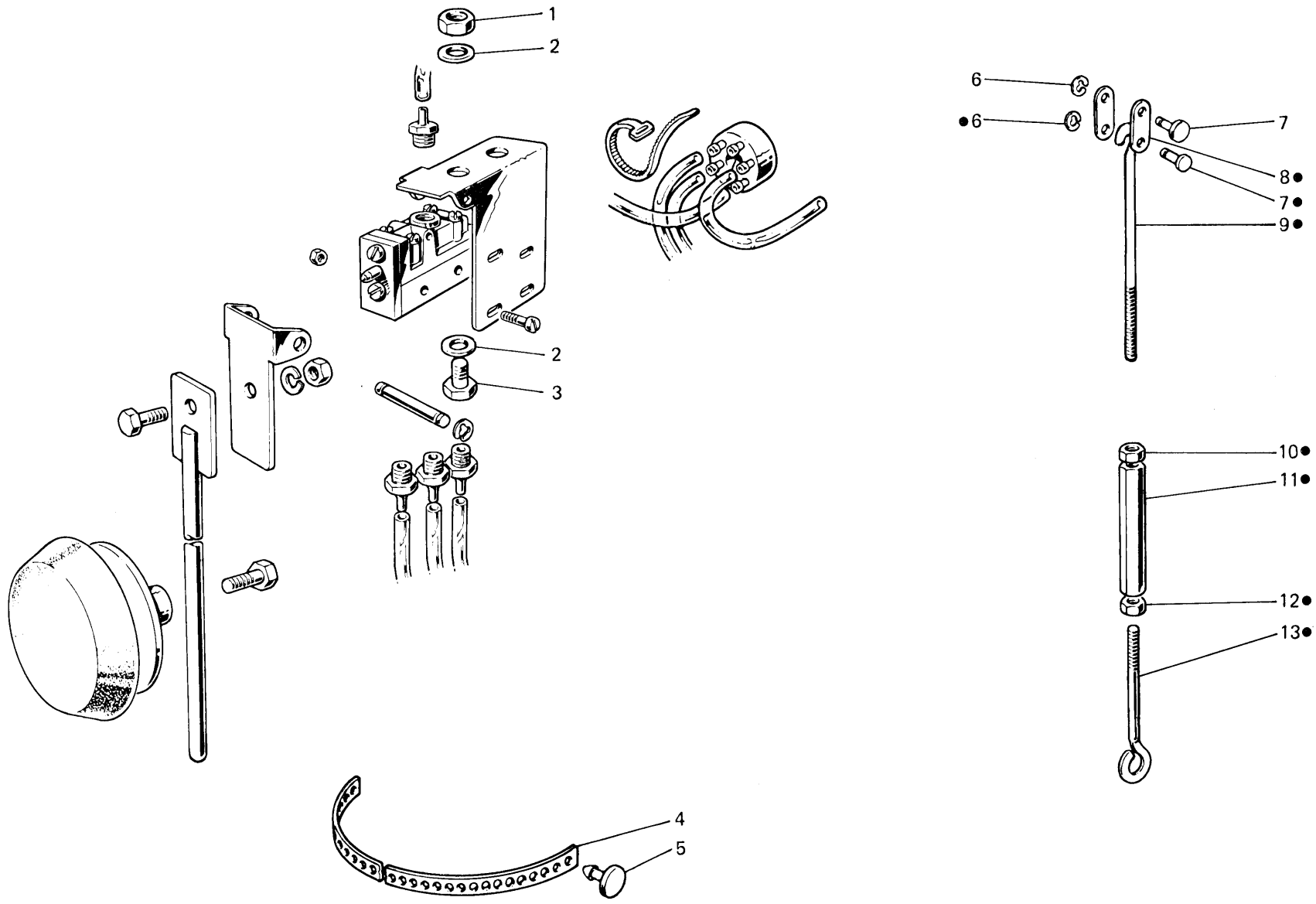

Fig. N. Abb. N.	Part. N. Bestell N. Piece N. Pieza N.	Qt. Anzahl	DESCRIZIONE	DESCRIPTION	DESCRIPTION	BENENNUNG	DESCRIPCION
●	910214-4-11	1	tirante completo	tie-rod assembly	tirant complet		
1	733510-2-00	1	dado	nut	écrou		
2	704232-2-00	2	rondella	washer	rondelle		
3	720485-2-00	1	vite	screw	vis		
4	990441-0-10	3	cinturino	strap	bride		
5	990442-0-10	3	bottoncino	button	bouton		
6	700205-0-00	2	anello elastico	spring ring	anneau ressort		
7	203211-0-10	2	perno	pin	pivot		
8	990765-0-00	2	piastrina	plate	plaque		
9	910187-0-11	1	tirante superiore	upper tie-rod	tirant supérieur		
10	733505-2-00	1	dado	nut	écrou		
11	910190-0-10	1	bussola	bush	bague		
12	746601-2-00	1	dado	nut	écrou		
13	910213-0-10	1	tirante inferiore	lower tie-rod	tirant inférieur		

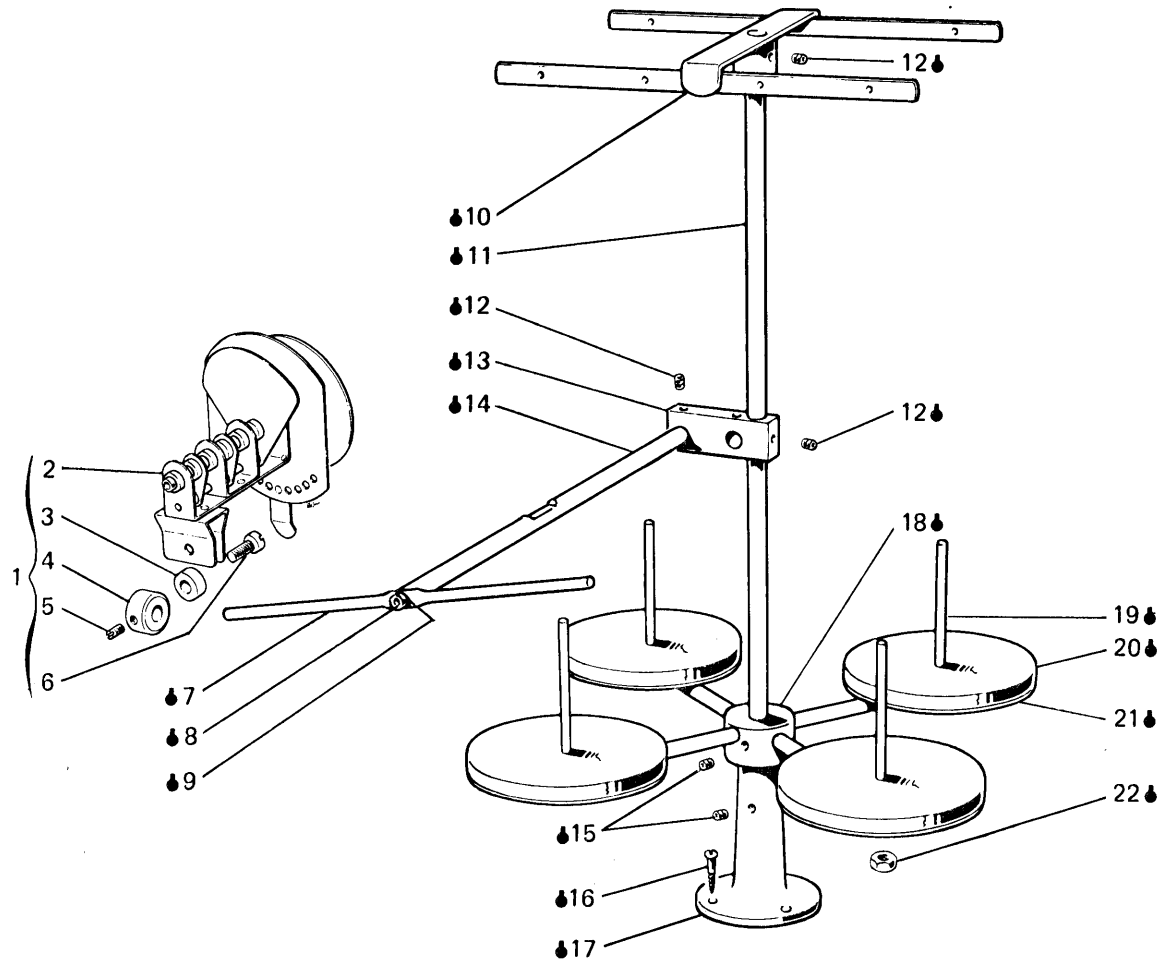

Fig. N. Abb. N.	Part. N. Bestell N. Piece N. Pieza N.	Qt. Anzahl	DESCRIZIONE	DESCRIPTION	DESCRIPTION	BENENNUNG	DESCRIPCION
•	924155-5-00	1	porta bobine completo (3-4fili)	bobbin carrier ass. (3-4 threads)	porte bobine compl. (3-4 fils)		
1	991158-4-00	3	frenaggio completo	brake assembly	freinage complet		
2	990445-0-10	3	frenaggio	brake	freinage		
3	304257-0-10	3	distanziale	spacer	entretoise		
4	991159-0-00	3	anello	ring	anneau		
5	727014-2-00	3	vite	screw	vis		
6	741956-2-00	3	vite	screw	vis		
7	991152-0-00	1	astina	rod	tige		
8	722431-2-00	1	vite	screw	vis		
9	703005-0-00	1	rondella	washer	rondelle		
10	991121-3-00	1	telaietto super. con vite	upper frame with screw	bâti supérieur avec vis		
11	991113-0-00	1	asta principale	main rod	tige principale		
12	729034-2-00	3	vite	screw	vis		
13	991128-2-00	1	blocchetto con viti	block with screws	bloc avec vis		
14	991106-2-00	1	asta con rondella e vite	rod with washer and screw	tige avec rondelle et vis		
15	729054-2-00	3	vite	screw	vis		
16	731107-2-00	3	vite da legno	screw	vis		
17	991114-2-00	1	basetta con vite	base with screw	base avec vis		
18	991129-3-00	1	mozzo con aste e viti	hub with rods and screws	moyeu avec tiges et vis		
19	991111-2-00	4	astina con dadi	rod with nuts	tige avec écrou		
20	991179-0-00	4	disco	disc	disque		
21	991112-0-00	4	piatto	disc	plateau		
22	733508-2-00	8	dado	nut	écrou		



Virginio Rimoldi & C. S.p.A.
Rockwell International

9, via Vespri Siciliani — 20146 Milano, Italy
Telefono: 470.152 - 470.081 — Telex: 33120
Telegr. VIRIMOLDI - P.O.B. 1482

Printed in Italy